

CAMPUS PUBLIC SAFETY BUILDING

DSA SET

COMPTON CCD

LITTLE
DIVERSIFIED ARCHITECTURAL CONSULTING

1300 Dove Street, Suite 100
Newport Beach, CA 92660
T: 949.698.1400 F: 949.698.1433
www.littleonline.com
This drawing and the design shown are the property of Little Diversified Architectural Consulting. The reproduction, copying or other use of this drawing without the written consent is prohibited and any infringement will be subject to legal action.
© Little 2016

COMPTON
CCD

CAMPUS PUBLIC SAFETY BUILDING
1111 EAST ARTESIA BOULEVARD,
COMPTON CALIFORNIA 90221

APPLICABLE STATE CODES

- ALL CONSTRUCTION SHALL BE DONE IN ACCORDANCE WITH:
 - 2013 CALIFORNIA ADMINISTRATIVE CODE, PART 1, TITLE 24 C.C.R. *
 - 2013 CALIFORNIA BUILDING CODE (CBC), PART 2, TITLE 24 C.C.R.
 - 2012 INTERNATIONAL BUILDING CODE VOLUMES 1-2 & 2013 CALIFORNIA AMENDMENTS
 - 2013 CALIFORNIA ELECTRICAL CODE (CEC), PART 3, TITLE 24 C.C.R.
 - (2011 NATIONAL ELECTRICAL CODE & 2013 CALIFORNIA AMENDMENTS)
 - 2013 CALIFORNIA MECHANICAL CODE (CMC) PART 4, TITLE 24 C.C.R.
 - (2012 UNIFORM MECHANICAL CODE & 2013 CALIFORNIA AMENDMENTS)
 - 2013 CALIFORNIA PLUMBING CODE (CPC), PART 5, TITLE 24 C.C.R.
 - (2012 UNIFORM PLUMBING CODE & 2013 CALIFORNIA AMENDMENTS)
 - 2013 CALIFORNIA ENERGY CODE (CEC), PART 6, TITLE 24 C.C.R.
 - 2013 CALIFORNIA FIRE CODE, PART 8, TITLE 24 C.C.R.
 - (2012 INTERNATIONAL FIRE CODE & 2013 CALIFORNIA AMENDMENTS)
 - 2013 CALIFORNIA GREEN BUILDING STANDARDS CODE, PART 11, TITLE 24, CCR.
 - 2013 CALIFORNIA REFERENCED STANDARDS, PART 12, TITLE 24 C.C.R.
 - TITLE 19 C.C.R., PUBLIC SAFETY, STATE FIRE MARSHAL REGULATIONS
 - 2007 ASME A17.1 (w/ 17.1a/CSA B44-08 addenda) SAFETY CODE FOR ELEVATORS AND ESCALATORS

- ALL WORK AND MATERIALS SHALL BE IN FULL CONFORMANCE WITH THE REQUIREMENTS OF THESE CODES AND ALL APPLICABLE LOCAL ORDINANCES. WHERE CONTRACT DOCUMENTS EXCEED SUCH REQUIREMENTS, WITHOUT VIOLATING SUCH CODES, REGULATIONS AND ORDINANCES, CONTRACT DOCUMENTS TAKE PRECEDENCE. WHERE CODES CONFLICT, THE MORE STRINGENT SHALL APPLY.
- CHANGE TO THE APPROVED DRAWINGS AND SPECIFICATIONS SHALL BE MADE BY ADDENDA OR CONSTRUCTION CHANGE DOCUMENT (CCD) APPROVED BY DSA, AS REQUIRED BY SECTION 4-338, PART 1, TITLE 24, CCR.
- A DSA ACCEPTED TESTING LABORATORY DIRECTLY EMPLOYED BY THE DISTRICT (OWNER) SHALL CONDUCT ALL THE REQUIRED TESTS AND INSPECTIONS FOR THE PROJECT.
- GRADING PLANS, DRAINAGE IMPROVEMENTS, ROAD AND ACCESS REQUIREMENTS AND ENVIRONMENTAL HEALTH CONSIDERATIONS SHALL COMPLY WITH ALL LOCAL ORDINANCES.

* CALIFORNIA ADMINISTRATIVE CODE, PART 1, CHAPTER 10, ADMINISTRATIVE REGULATIONS FOR THE CALIFORNIA ENERGY COMMISSION (CEC).

PARTIAL LIST OF APPLICABLE STANDARDS

NFPA 10	STANDARD FOR PORTABLE FIRE EXTINGUISHERS	2013 EDITION
NFPA 24	PRIVATE FIRE SERVICE MAINS (CA AMENDED)	2016 EDITION
NFPA 72	NATIONAL FIRE ALARM & SIGNALING CODE (CA AMENDED)	2016 EDITION

(NOTE: SEE UL STANDARD 1971 FOR "VISUAL DEVICES")

NFPA 75	STANDARD FOR FIRE PROTECTION OF INFORMATION TECHNOLOGY EQUIPMENT	2013 EDITION
NFPA 80	STANDARD FOR FIRE DOORS AND OTHER OPENING PROTECTIVES	2016 EDITION
NFPA 2001	CLEAN AGENT FIRE EXTINGUISHING SYSTEMS	2015 EDITION

REFERENCE CODE SECTION FOR NFPA STANDARDS - 2013 CBC (SFM) CHAPTER 38. SEE CHAPTER 35 FOR STATE OF CALIFORNIA AMENDMENTS TO NFPA STANDARDS.

DEFERRED APPROVAL ITEMS

INSTALLATION OF DEFERRED APPROVAL ITEMS SHALL NOT BE STARTED UNTIL CONTRACTOR'S DRAWINGS, SPECIFICATIONS AND ENGINEERING CALCULATIONS FOR THE ACTUAL SYSTEMS TO BE INSTALLED HAVE BEEN ACCEPTED AND SIGNED BY THE ARCHITECT OR STRUCTURAL ENGINEER WHO HAS BEEN DELEGATED THE RESPONSIBILITY OF COVERING THE WORK SHOWN ON A PARTICULAR PLAN OR SPECIFICATION, AND APPROVED BY THE DIVISION OF THE STATE ARCHITECT. DEFERRED ITEMS SHALL BE COMPLETED PRIOR TO OCCUPANCY OF BUILDINGS AFFECTED BY THE DEFERRED WORK.

CHANGES TO THE APPROVED DRAWINGS AND SPECIFICATIONS SHALL BE MADE BY AN ADDENDA OR A CHANGE ORDER APPROVED BY THE DIVISION OF THE STATE ARCHITECT, AS REQUIRED BY SECTION 4-335, PART 1, TITLE 24, C.C.R.

ALL WORK SHALL CONFORM TO TITLE 24, CALIFORNIA CODE OF REGULATIONS (CCR).

DEFERRED APPROVAL ITEMS ARE AS FOLLOWS:

- THERE ARE NO DEFERRED APPROVALS ON THIS PROJECT.

THE PLANS AND SPECIFICATIONS SHALL BE STAMPED AND SIGNED BY THE ARCHITECT AND ENGINEER OF RECORD BEFORE SUBMITTAL TO DSA.

OVER ALL CAMPUS PLAN

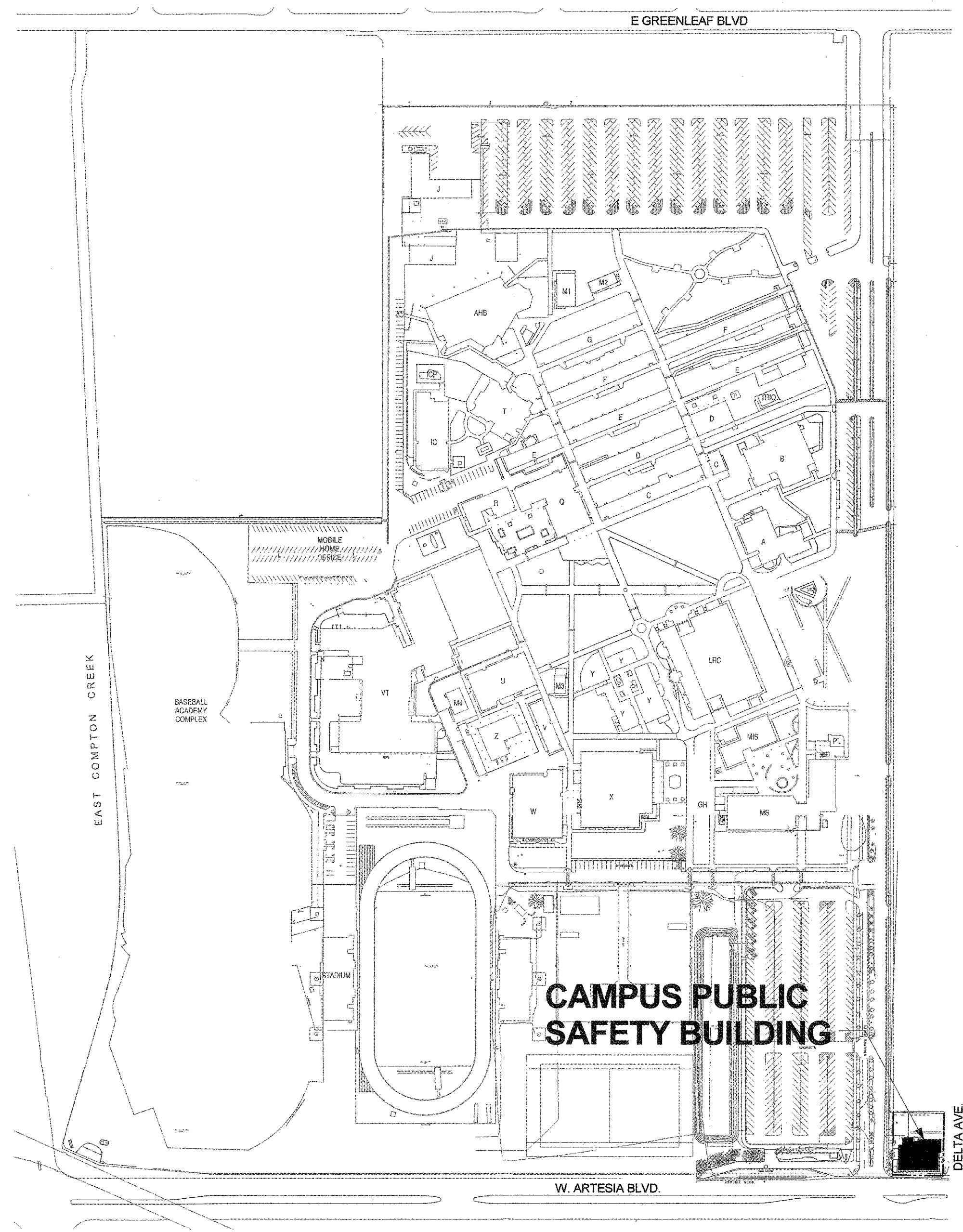

VICINITY MAP

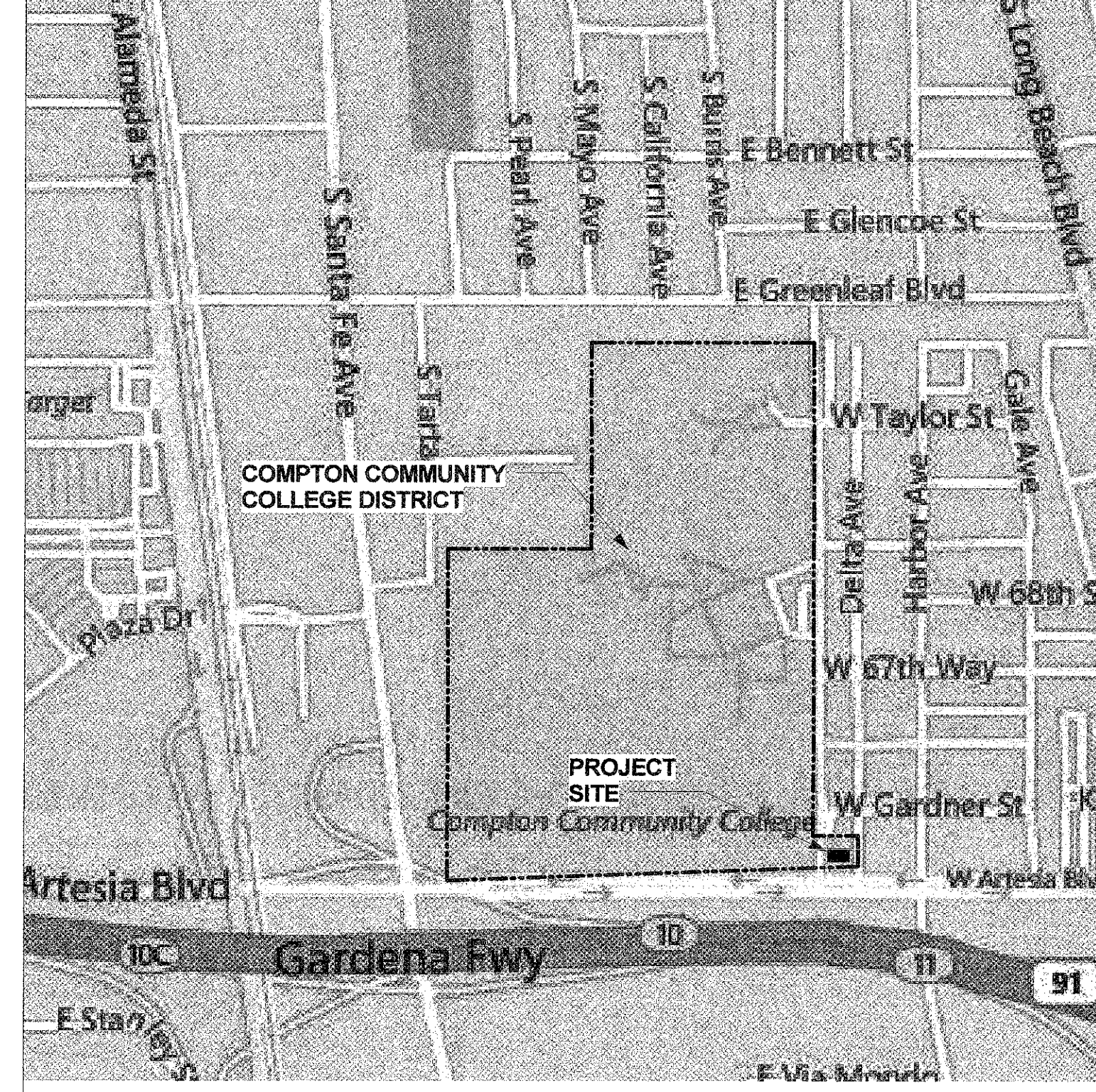

SITE ADDRESS: 1111 E ARTESIA BLVD., COMPTON, CA 90221

PROJECT PERSPECTIVE VIEW

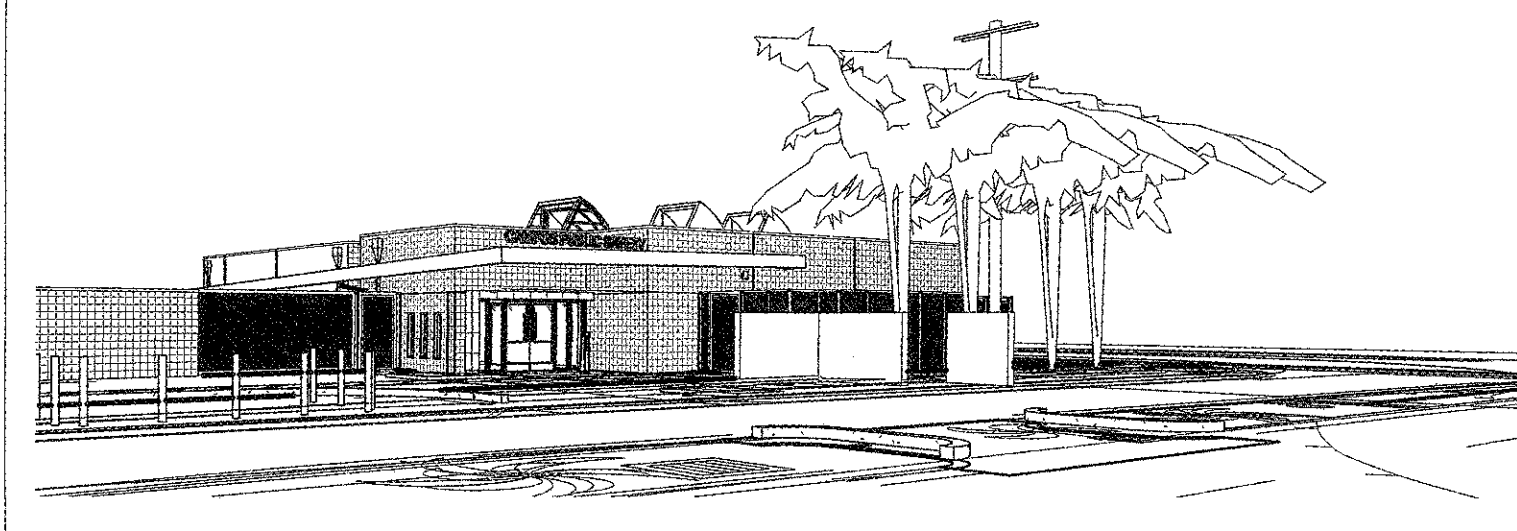

SHEET INDEX

GENERAL	MECHANICAL
G0.1.1 TITLE SHEET / SHEET INDEX	M0.0.1 MECHANICAL LEGEND, NOTES, & ABBREVIATIONS
G0.2.3 FIRE ACCESS SITE PLAN	M0.0.2 MECHANICAL SCHEDULES
G0.3.1 ACCESSIBILITY & BUILDING EXIT ANALYSIS	M0.0.3 TITLE 24 REPORT
	M0.0.4 TITLE 24 REPORT
CIVIL	M2.1.1 MECHANICAL - FLOOR PLAN
C1.0 TITLE SHEET	M2.1.2 MECHANICAL-ROOF PLAN
C1.1 GRADING PLAN	M2.2.1 MECHANICAL-PIPING PLAN
C1.2 GRADING DETAIL SHEET	M5.0.1 MECHANICAL DETAILS
C1.3 GRADING DETAIL SHEET	M5.0.2 MECHANICAL DETAILS
	M5.0.1 MECHANICAL CONTROLS
LANDSCAPE	M6.0.2 MECHANICAL CONTROLS
L-1 IRRIGATION PLAN	M6.0.3 MECHANICAL SEQUENCE OF OPERATION
L-2 LANDSCAPE NOTES & LEGENDS	
L-3 PLANTING PLAN	
L-4 LANDSCAPE DETAILS	
L-5 LANDSCAPE DETAILS	
ARCHITECTURAL	PLUMBING
A0.0.1 GENERAL NOTES	P0.0.1 PLUMBING - LEGEND AND GENERAL NOTES
A0.2.1 SYMBOLS / ABBREVIATIONS	P0.0.2 PLUMBING SCHEDULES
A1.1.1 SITE PLAN	P1.1.1 PLUMBING - SITE PLAN
A1.3.1 SITE DETAILS	P2.1.1 PLUMBING - FLOOR PLAN
A1.3.2 SITE DETAILS	P2.2.1 PLUMBING - ROOF PLAN
A1.3.3 SITE DETAILS	P4.0.1 PLUMBING - RISER DIAGRAMS
A2.1.1 FLOOR PLAN	P5.0.1 PLUMBING - DETAILS
A3.0.1 DETAILED FLOOR PLANS & INTERIOR ELEVATIONS	
A4.1.1 REFLECTED CEILING PLAN	ELECTRICAL
A5.0.1 ROOF PLAN	E0.0.1 ELECTRICAL LEGEND AND NOTES
A6.0.1 EXTERIOR ELEVATIONS	E0.0.2 SINGLE LINE DIAGRAM & SCHEDULES
A6.1.1 BUILDING SECTIONS	E0.0.3 LIGHTING FIXTURE SCHEDULE
A6.2.1 WALL SECTIONS	E0.0.4 ELECTRICAL DETAILS
A6.0.1 ROOM FINISH, DOOR, & WINDOW SCHEDULE	E0.0.5 ELECTRICAL DETAILS
A6.0.1 WALL TYPES SHALL PROVIDE CONTINUOUS INSULATION OF THE WALL	E0.0.6 ELECTRICAL DETAILS
A9.0.2 TYP. MTL. STUD FRAMING & EXTERIOR DETAILS	E0.0.7 ELECTRICAL DETAILS
A9.1.1 ROOF DETAILS	E0.0.8 INDOOR TITLE 24 COMPLIANCE FORMS
A9.1.2 CEILING DETAILS	E0.0.9 OUTDOOR TITLE 24 COMPLIANCE FORMS
A9.1.3 ROOF & CEILING DETAILS	E1.1.0 ELECTRICAL OVERALL SITE PLAN
A9.1.4 CLEARESTORY DETAILS	E1.1.1 ELECTRICAL SITE PLAN
A9.1.5 DETAILS	E2.1.1 LIGHTING PLAN
A9.3.1 HOLLOW METAL DOOR DETAILS	E2.1.2 POWER & SIGNAL PLAN
A9.3.2 ALUMINUM DOOR & WINDOW DETAILS	E2.1.3 ELECTRICAL MECHANICAL POWER PLAN
A9.6.1 INTERIOR DETAILS	E3.1.1 ELECTRICAL ROOF PLAN
A9.6.2 SIGNAGE DETAILS	
A9.6.3 MILLWORK DETAILS	
STRUCTURAL	FIRE ALARM
S0.1 GENERAL NOTES	FA0.1 FIRE ALARM LEGENDS & NOTES
S0.2 GENERAL NOTES	FA0.2 FIRE ALARM RISER DIAGRAM
S1.1 TYPICAL DETAILS	FA0.3 FIRE ALARM DETAILS
S1.2 TYPICAL DETAILS	FA0.4 FIRE ALARM CALCULATIONS
S1.3 TYPICAL DETAILS	FA0.5 FIRE ALARM PLAN
S1.4 TYPICAL DETAILS	FA0.5.1 FIRE ALARM DETAILS
S1.5 TYPICAL DETAILS	FA0.5.2 FIRE ALARM DETAILS
S2.1 FOUNDATION PLAN	TOTAL: 94
S2.2 ROOF FRAMING PLAN	
S4.1 FOUNDATION DETAILS	
S5.1 MASONRY DETAILS	
S5.2 MASONRY DETAILS	
S5.3 MASONRY DETAILS	
S6.1 STEEL DETAILS	
S6.2 STEEL DETAILS	

CODE ANALYSIS

BUILDING DATA

- OCCUPANCY GROUP: B
- SECONDARY OCCUPANCY GROUP: N/A
- RISK CATEGORY: IV
- TYPE OF CONSTRUCTION: V-B, NON-RATED
- FIRE SPRINKLER: N/A
- ACTUAL STORIES: 1-STORY
- TOTAL ACTUAL BUILDING AREA: 5,550 SF
- PER 2013 CBC TABLE 503, ALLOWABLE BUILDING STORIES:
BASIC ALLOWABLE STORIES: 2 STORIES
ACTUAL STORIES: 1 STORY < 2 STORIES, THEREFORE: COMPLIANT
- PER 2013 CBC TABLE 503, ALLOWABLE BUILDING HEIGHT:
BASIC ALLOWABLE HEIGHT: 40 FT
ACTUAL BUILDING HEIGHT: 14' - 8" FT < 40 FT, THEREFORE: COMPLIANT
- PER 2013 CBC TABLE 503, ALLOWABLE FLOOR AREA:
BASIC ALLOWABLE FLOOR AREA: 9,000 SF / STORY
ACTUAL BUILDING AREA: 5,550 SF < 9,000 SF, THEREFORE: COMPLIANT

FIRE-RESISTANCE RATING REQUIREMENTS PER 2013 CBC TABLE 601

CONSTRUCTION TYPE: VB	REQUIRED	PROVIDED
PRIMARY STRUCTURAL FRAME	0	0
EXT. BEARING WALLS	0	0
INT. BEARING WALLS	0	0
EXT. NON BEARING WALLS & PARTITIONS	0	0
INT. NON BEARING WALLS & PARTITIONS	0	0
FLOOR CONSTRUCTION & SECONDARY MEMBERS	0	0
ROOF CONSTRUCTION & SECONDARY MEMBERS	0	0
ROOF MEMBERS ARE < 20 FT	0	0
ROOF MEMBERS ARE > 20 FT	0	0

FIRE-RESISTANCE RATING REQUIREMENTS PER 2013 CBC TABLE 602

CONSTRUCTION TYPE: VB	REQUIRED	PROVIDED
OCCUPANCY: B	0	0
SEPARATION DISTANCE X > 30'	0	0

PLUMBING FIXTURE COUNT PER 2013 CPC TABLE 422.1

38 TOTAL OCCUPANCY OF BUILDING SPACES

REQ.	WC	U	L	DF
18 MEN	1	0	1	1
18 WOMEN	1	1	1	1
			2	

PROV.	WC	U	L	DF
18 MEN	1	0	1	1
18 WOMEN	1	1	1	1
			2	

THEREFORE, ACTUAL PROVIDED PLUMBING FIXTURE COUNT COMPLIANT W/ 2013 CPC.

PROJECT DIRECTORY

PROJECT
CAMPUS PUBLIC SAFETY BUILDING
COMPTON COMMUNITY COLLEGE DISTRICT
1111 E ARTESIA BLVD., COMPTON, CA 90221

OWNER
COMPTON COMMUNITY COLLEGE DISTRICT
1111 E ARTESIA BLVD., COMPTON, CA 90221
(310) 900-1600

ARCHITECT
LITTLE
1300 DOVE STREET, SUITE 100
NEWPORT BEACH, CA 92660
(949) 698-1400
(949) 698-1433 (FAX)

CIVIL
FRL & ASSOCIATES, INC.
10 CORPORATE PARK, SUITE 310
IRVINE, CA 92606
(949) 252-1686

STRUCTURAL
TTG. T.MAD TAYLOR & GAINES
901 VIA PIEMONTE, SUITE 400
ONTARIO, CA 91754
(909) 477-8915

MECHANICAL / ELECTRICAL / PLUMBING
dHA + Calcep
150 S. ARROYO PARKWAY, SUITE NO. 100
PASADENA, CA 91105
(626) 445-8500

LANDSCAPE
TOLA, INC.
22792 CENTRE DRIVE, #107
LAKE FOREST, CA 92630
(949) 250-1616
(949) 916-942 (FAX)

CONSTRUCTION MANAGERS
PCM3
970 BRIGHTON CT., 3RD FLOOR
SAN DIMAS, CA 91773
(909) 592-4888

PROJECT DESCRIPTION

WORK UNDER THIS CONTRACT INCLUDES THE FOLLOWING AREAS, AS SHOWN ON THE DRAWINGS, SPECIFIED IN THE PROJECT MANUAL, AND DEFINED IN THE PROJECT CONTRACT DOCUMENTS. INCLUDING BUT NOT NECESSARILY LIMITED TO:
NEW CONSTRUCTION OF MINOR SITE IMPROVEMENTS & A ONE-STORY PUBLIC SAFETY BUILDING CONTAINING LOBBY, OFFICES, LOCKER ROOMS, AND ACCESSORY SUPPORT SPACES.

PROJECT INSPECTOR

A "DSA CERTIFIED" PROJECT INSPECTOR OF RECORD (IOR) EMPLOYED BY THE DISTRICT (OWNER) AND APPROPRIATELY LICENSED UNDER SECTION 43922 AND 43138 OF THE EDUCATION CODE AND SECTION 4-336, 4-341 AND 4-342 OF TITLE 24, PART 1, TITLE 24, CCR AND IIR A-7. INSPECTOR SHALL BE CLASS 1.

Statement of General Conformance
FOR ARCHITECTS/ENGINEERS WHO UTILIZE PLANS, INCLUDING BUT NOT LIMITED TO SHOP DRAWINGS, PREPARED BY OTHER LICENSED DESIGN PROFESSIONALS AND/OR CONSULTANTS
(Application No. 09-117973 File No. 18-25)

The drawings or sheets listed on the cover or index sheet
 This drawing, page or specification
I, as a duly licensed and qualified design professional, have prepared or supervised the preparation of the drawings or sheets and I am not aware of any fraud or other intentional or negligent misrepresentation in the drawings or sheets.

design intent and appears to meet the appropriate requirements of Title 24, California Code of Regulations and the project specifications prepared by me, and
 certification with my date and specifications and is acceptable for incorporation into the construction of this project.

The Statement of General Conformance "shall not be construed as relieving me of my rights, duties, and responsibilities under Sections 43922 and 43138 of the Education Code and Sections 4-336, 4-341 and 4-342 of Title 24, Part 1, Title 24, CCR and IIR A-7 (b) (3) (1) (i).

I certify that: All drawings or sheets listed on the cover or index sheet
 This drawing or page
 have been prepared and checked in general conformance and
 have been signed and dated.

Signature: *Rita S. Carter* Date: 12/19/17

Architect or Engineer designated to be in general responsible charge
Rita S. Carter
Print Name: Rita S. Carter
Title: Architect
License Number: 4-30-2019 Expiration Date

IDENTIFICATION STAMP
DIV. OF THE STATE ARCHITECT
OFFICE OF REGULATION SERVICES
FILE NO: 19-C1
AR: 03-117973
AC: MF FS: SS:
DATE: DEC 12 2017

PROJECT TEAM
PRINCIPAL IN CHARGE
RITA S. CARTER
PROJECT MANAGER
SHOJI TAKEISHIMA / DAVID PHAN
DRAWN BY
DAVID PHAN
REVISIONS
NO REASON DATE

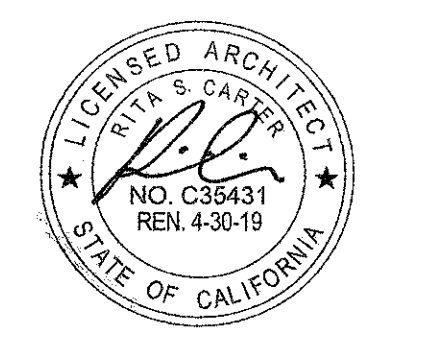

TITLE SHEET / SHEET INDEX

913-4675-00

12/01/16 G0.1.1

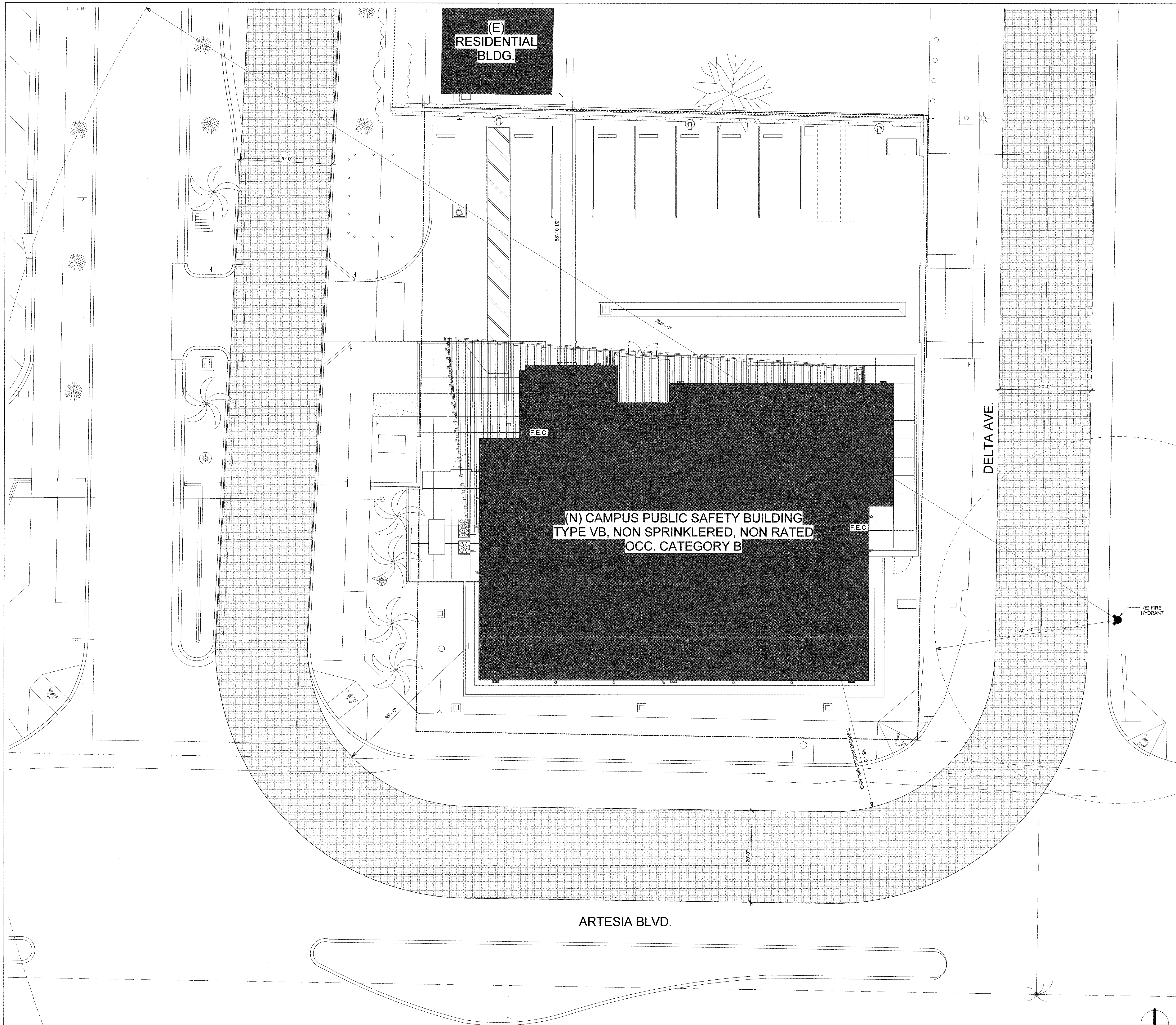

DSA 810
LOCAL FIRE AUTHORITY REVIEW

To facilitate the Director of the State Architect's (DSA) approval of the Fire/Arts Safety portion of a project, DSA requires Local Fire Authority (LFA) review of the Fire/Arts Safety portion of a project. Use of this form is mandatory for projects that will require a permit to a campus or if any item on this form is relevant to this project. For additional information, see DSA's Construction and Code Division (C&CD).

PROJECT INFORMATION
 School District/Owner: Compton Community College District
 Project Name/Address: Campus Public Safety Building
 Project Address: 1111 E. Artesia Blvd., Compton, CA 90221

LOCAL FIRE AUTHORITY (LFA)
 LFA Name: City of Compton Fire Department
 LFA Address: 1111 E. Artesia Blvd., Compton, CA 90221
 LFA Phone: (310) 425-4272
 LFA Fax: (310) 425-4272
 LFA Representative: [Signature] Title: Fire Chief
 Date: 9/19/2016

REVIEW KEY:
 "P" = Change why LFA requirements "N" = Not approved (Complete Section B)
 "M" = Not approved in the subject "M" = LFA items, not to review

Item	Description	Y	N	M	Other
1	Where applicable, does not meet minimum emergency service call data, per the California Building Code (CBC), use of alternate for emergency response and pre-incident response.				
2	Access roads, fire lane markings, pavers and gate entrances are in accordance with Title 24, California Code of Regulations and the California Fire Code, Chapter 9.				
3	Fire hydrant location and distribution complies with the California Fire Code or any 9-4.				
4	Fire hydrant location and distribution complies with NFPA 1142, "Alternate Means." If "N" is checked, DSA can only approve on-site water storage as an alternate. The signature of the school district official is required to acknowledge the use of alternate means.				
5	Signature of School District Official: [Signature] Title: Fire Chief				
6	The location(s) of the proposed fire hydrant valve and the department connection must be in accordance with the requirements of the California Fire Code.				
7	The location(s) of the detector check valve assembly must be in accordance with the requirements of the California Fire Code.				
8	Is the project located in a hazard severity zone area? (CBC, Chapter 7A, Section 701A) Yes <input type="checkbox"/> No <input checked="" type="checkbox"/>				
9	Check type of fire: <input type="checkbox"/> Woodsmoke <input type="checkbox"/> High <input type="checkbox"/> Very High <input type="checkbox"/> Very High				
10	Check type of fire: <input type="checkbox"/> Woodsmoke <input type="checkbox"/> High <input type="checkbox"/> Very High <input type="checkbox"/> Very High				

COMMENTS (note deficiencies):

September 6, 2016

Long Beach Water Department
 Environmental Stewardship
 CHRISTOPHER A. GARRER, General Manager

Mr. David Phan
 Little Diversified Architectural Consulting
 1300 Dove Street, Suite 100
 Newport Beach, CA 92660

Dear Mr. Phan:

In response to your request to perform a fire flow test for 1989 W. Artesia Boulevard, the following data was furnished:

Flow Test No. 1529 Date of Test: 8/30/16
 Fire Location: Fire Hydrant located at 239 W. Artesia Blvd.
 Fire Pressure: 52 psi
 4" Outlet Chart Reading: 2150 gpm
 Pressure Reading: Fire Hydrant located at 6024 Delta Ave.
 Static Pressure: 57 psi
 Residual Pressure: 52 psi
 Size of Water Main: 12" CI Main along Artesia Blvd.

The flow test represents data taken on the above data. Flows and pressures are subject to seasonal and time of day demand variations and fluctuations in reservoir levels and these variations may be significant. The data represents hydraulic capacity in the vicinity of the test site only and care should be taken in extrapolating data to other areas.

If you have any questions, please call Dennis Santos at (562) 570-2361.

Sincerely,
 [Signature]
 Dennis A. Santos, P.E.
 Civil Engineer

cc: Lisa Crowley, Engineering Intern L.C.

SYSTEM HYDRAULIC INFORMATION

DATE: BY:

HIGH WATER RESERVOIR LEVEL:	MWD CONNECTION:
ALAMITOS: 24.4 FEET	LB-8 FLOW PRESSURE: 8 MGD PSI
J. WILL JOHNSON: 25.41 FEET	LB-4 FLOW PRESSURE: 5.73 MGD PSI

CHUMEN PUMP STATION: 42 INCH WATER MAIN

FLOW:	5.50 MGD	OFFER	MGD
PRESSURE:	24.35 PSI	CLOSED	MGD

REFERENCE FIRE FLOW TEST NUMBER: 1529
 The Alamitos Reservoir Tank Bottom Elevation is 170 Feet.
 The J. Will Johnson Reservoir Tank Bottom Elevation is 170 Feet.

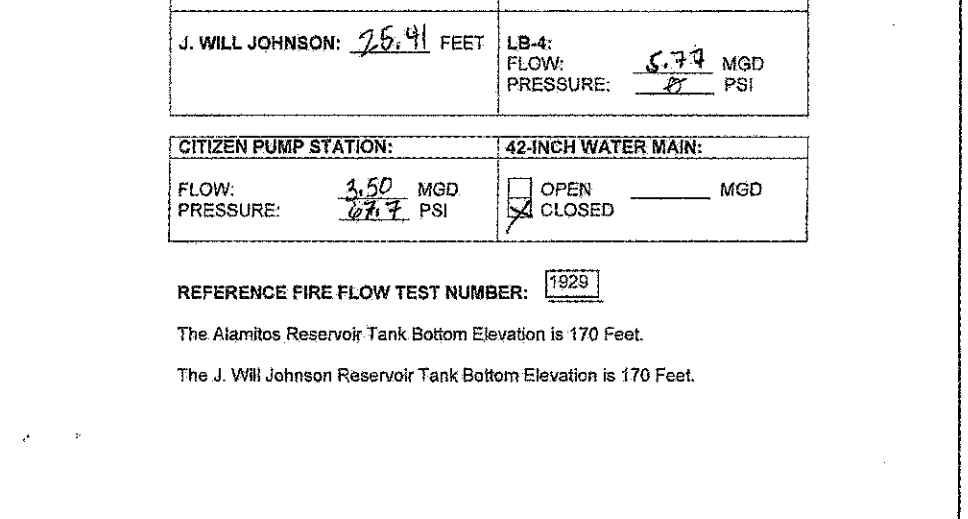

IDENTIFICATION STAMP
 DIV. OF THE STATE ARCHITECT
 OFFICE OF REGULATION SERVICES

FILE NO: 16-C1
 AR: 03-117973
 DATE: DEC 12 2017

PROJECT TEAM
 PRINCIPAL IN CHARGE: RITA S. CARTER
 PROJECT MANAGER: SHOJI TAKESHIMA / DAVID PHAN
 DRAWN BY: DAVID PHAN

NO	REASON	DATE

LEGEND

- [Symbol] FIRE LANE - 20'-0" WIDE MINIMUM, U.N.O.
- [Symbol] (E) FIRE HYDRANT
- [Symbol] ASSUMED PROPERTY LINE

GENERAL NOTES

1. SEE CIVIL DRAWINGS FOR SITE EXCAVATION, GRADING, DRAINAGE, WATER, SEWER, PAVING, HORIZONTAL AND VERTICAL CONTROL, AND ADDITIONAL SITE AND CONSTRUCTION INFORMATION.

LOCAL FIRE AUTHORITY ACCESS SITE PLAN
 00.2.3
 1/8" = 1'-0"

LITTLE
 DIVERSIFIED ARCHITECTURAL CONSULTING

1300 Dove Street, Suite 100
 Newport Beach, CA 92660
 T: 949.698.1400 F: 949.698.1433
 www.littleonline.com

This drawing and the design shown are the property of Little Diversified Architectural Consulting. The reproduction, copying or other use of this drawing without their written consent is prohibited and any infringement will be subject to legal action.

© Little 2016

COMPTON CCD

CAMPUS PUBLIC SAFETY BUILDING
 1111 EAST ARTESIA BOULEVARD,
 COMPTON CALIFORNIA 90221

AGENCY REVIEW

IDENTIFICATION STAMP
 DIV. OF THE STATE ARCHITECT
 OFFICE OF REGULATION SERVICES

FILE NO: 16-C1
 AR: 03-117973
 DATE: DEC 12 2017

PROJECT TEAM
 PRINCIPAL IN CHARGE: RITA S. CARTER
 PROJECT MANAGER: SHOJI TAKESHIMA / DAVID PHAN
 DRAWN BY: DAVID PHAN

ISSUES

NO	REASON	DATE



SHEET TITLE
 FIRE ACCESS SITE PLAN

PROJECT NUMBER
 913-4675-00

ISSUE DATE
 12/01/16

SHEET NO.
 G0.2.3

This drawing and the design shown are the property of Little Diversified Architectural Consulting. The reproduction, copying or other use of this drawing without their written consent is prohibited and any infringement will be subject to legal action.
© Little 2016

CLIENT NAME
COMPTON CCD

PROJECT NAME
CAMPUS PUBLIC SAFETY BUILDING

1111 EAST ARTESIA BOULEVARD,
COMPTON CALIFORNIA 90221

IDENTIFICATION STAMP
DIV. OF THE STATE ARCHITECT
OFFICE OF REGISTRATION SERVICES
FILE NO: 19-C1
AR: 03-117873
DATE: DEC 12 2017

PRINCIPAL IN CHARGE
RITA S. CARTER
PROJECT MANAGER
SHOJI TAKESHIMA / DAVID PHAN
DRAWN BY
DAVID PHAN

NO REASON DATE

NOTES

SEAL / SIGNATURE

ACCESSIBILITY & BUILDING EXIT ANALYSIS

913-4675-00

12/01/16 G0.3.1

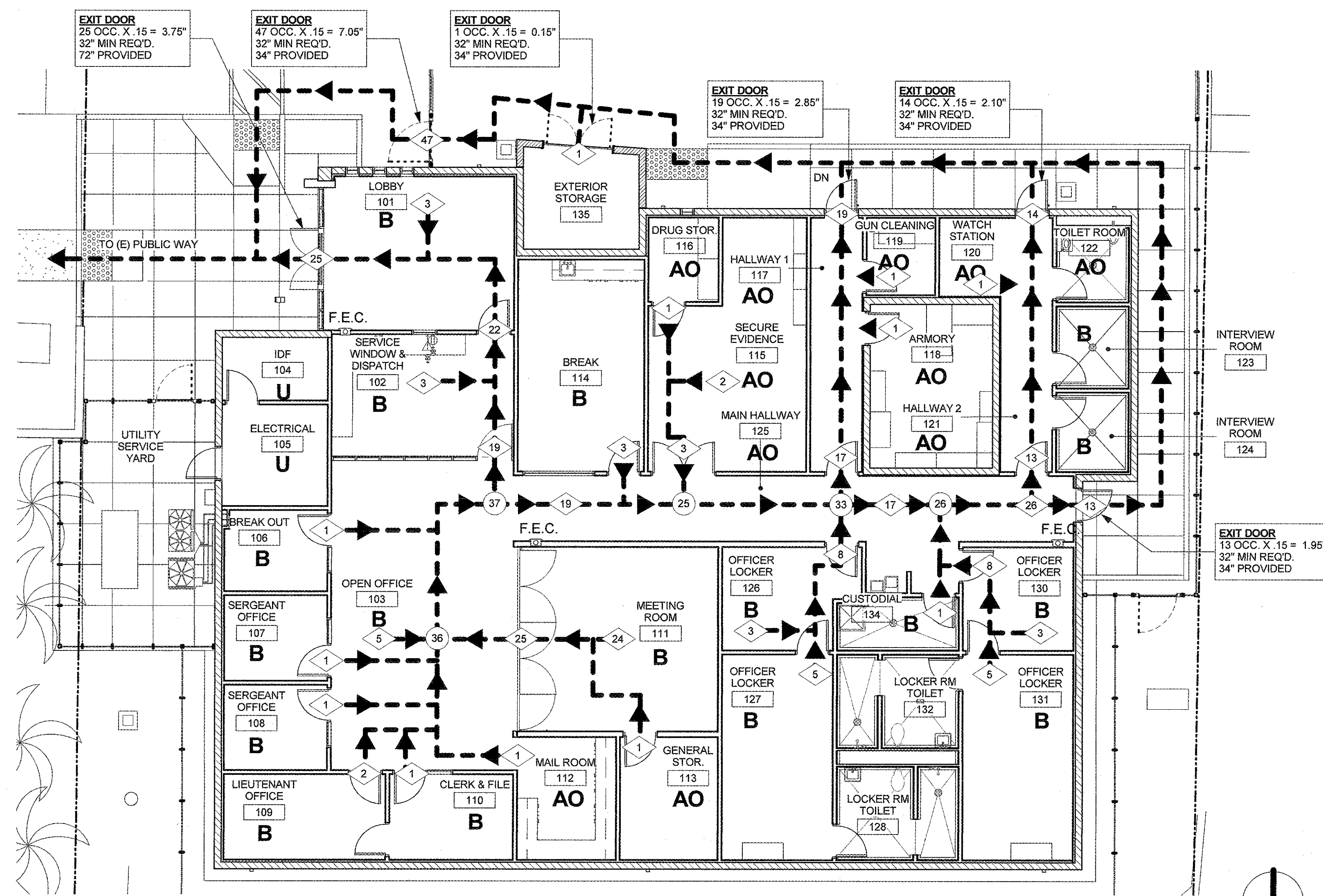

1 OCCUPANCY & EXIT ANALYSIS
G0.3.1 1/8" = 1'-0"

EXITING ANALYSIS									
NO.	ROOM NAME	AREA	OCC. TYPE	LOAD FACTOR	OCC. LOAD	# OF EXITS REQ'D	EXIT WIDTH FACTOR	EXIT WIDTH REQ'D	EXIT WIDTH PROVIDED
101	LOBBY	280 SF	B	100	3	1	0.15	0.45	72"
102	SERVICE WINDOW & DISPATCH	211 SF	B	100	3	1	0.15	0.45	34"
103	OPEN OFFICE	406 SF	B	100	6	1	0.15	0.75	34"
104	IDF	63 SF	AO	0	1	1	0.15	0	34"
105	ELECTRICAL	102 SF	AO	0	1	1	0.15	0	34"
106	BREAK OUT	79 SF	B	100	1	1	0.15	0.15	34"
107	SERGEANT OFFICE	84 SF	B	100	1	1	0.15	0.15	34"
108	SERGEANT OFFICE	84 SF	B	100	1	1	0.15	0.15	34"
109	LIEUTENANT OFFICE	131 SF	B	100	2	1	0.15	0.3	34"
110	CLERK & FILE	100 SF	B	100	1	1	0.15	0.15	34"
111	MEETING ROOM	548 SF	B - ASSEMBLY	15	24	1	0.15	3.6	>17"
112	MAIL ROOM	116 SF	AO - STORAGE	300	1	1	0.15	0.15	34"
113	GENERAL STOR.	113 SF	AO - STORAGE	300	1	1	0.15	0.15	34"
114	BREAK	255 SF	B	100	3	1	0.15	0.45	34"
115	SECURE EVIDENCE	316 SF	AO - STORAGE	300	2	1	0.15	0.3	68"
116	DRUG STOR.	56 SF	AO - STORAGE	300	1	1	0.15	0.15	34"
117	HALLWAY 1	126 SF	AO	0	1	1	0.15	0	34"
118	ARMORY	192 SF	AO - STORAGE	300	1	1	0.15	0.15	34"
119	GUN CLEANING	50 SF	AO - STORAGE	300	1	1	0.15	0.15	34"
120	WATCH STATION	44 SF	AO - STORAGE	300	1	1	0.15	0.15	>7"
121	HALLWAY 2	127 SF	AO	0	1	1	0.15	0	34"
122	TOILET ROOM	51 SF	AO	0	1	1	0.15	0	34"
123	INTERVIEW ROOM	56 SF	B	100	1	1	0.15	0.15	34"
124	INTERVIEW ROOM	54 SF	B	100	1	1	0.15	0.15	34"
125	MAIN HALLWAY	540 SF	AO	0	1	1	0.15	0	2 x 34"
126	OFFICER LOCKER	122 SF	B - LOCKER RM	50	3	1	0.15	0.45	34"
127	OFFICER LOCKER	215 SF	B - LOCKER RM	50	5	1	0.15	0.75	34"
128	LOCKER RM TOILET	88 SF	AO	0	1	1	0.15	0	34"
129	SHOWER	37 SF	AO	0	1	1	0.15	0	34"
130	OFFICER LOCKER	108 SF	B - LOCKER RM	50	3	1	0.15	0.45	34"
131	OFFICER LOCKER	215 SF	B - LOCKER RM	50	5	1	0.15	0.75	34"
132	LOCKER RM TOILET	89 SF	AO	0	1	1	0.15	0	34"
133	SHOWER	37 SF	AO	0	1	1	0.15	0	34"
134	CUSTODIAL	56 SF	AO - STORAGE	300	1	1	0.15	0.15	34"
135	EXTERIOR STORAGE	109 SF	AO - STORAGE	300	1	1	0.15	0.15	2 x 36"

LEGEND

- ROOM NAME
X ROOM NAME / ROOM NUMBER
- M CUMULATIVE OCCUPANCY
- X EXITING OCCUPANTS
- EXIT PATH OF TRAVEL

OCCUPANCY GROUP

- B** BUSINESS OCCUPANCY (OFFICE & EDUCATIONAL OCCUPANCIES ABOVE 12TH GRADE)
- AO** ACCESSORY OCCUPANCY (CORRIDORS, TOILET ROOMS, SHOWERS, STORAGE, ETC.)
- U** ELECTRICAL & IDF ROOMS

NOTES

- "DESIGN PROFESSIONAL IN GENERAL RESPONSIBLE CHARGE STATEMENT: THE POT IDENTIFIED IN THESE CONSTRUCTION DOCUMENTS IS COMPLIANT WITH THE CURRENT APPLICABLE CALIFORNIA BUILDING CODE ACCESSIBILITY PROVISIONS FOR PATH OF TRAVEL REQUIREMENTS FOR ALTERATIONS, ADDITIONS AND STRUCTURAL REPAIRS, AS PART OF THE DESIGN OF THIS PROJECT, THE POT WAS EXAMINED AND ANY ELEMENTS, COMPONENTS OR PORTIONS OF THE POT THAT WERE DETERMINED TO BE NONCOMPLIANT 1) HAVE BEEN IDENTIFIED AND 2) THE CORRECTIVE WORK NECESSARY TO BRING THEM INTO COMPLIANCE HAS BEEN INCLUDED WITHIN THE SCOPE OF THIS PROJECT'S WORK THROUGH DETAILS, DRAWINGS AND SPECIFICATIONS INCORPORATED INTO THESE CONSTRUCTION DOCUMENTS. ANY NONCOMPLIANT ELEMENTS, COMPONENTS OR PORTIONS OF THE POT THAT WILL NOT BE CORRECTED BY THIS PROJECT BASED ON VALUATION THRESHOLD LIMITATIONS OR A FINDING OF UNREASONABLE HARSHNESS ARE SO INDICATED IN THESE CONSTRUCTION DOCUMENTS.
- DURING CONSTRUCTION, IF POT ITEMS WITHIN THE SCOPE OF THE PROJECT REPRESENTED AS CODE COMPLIANT ARE FOUND TO BE NONCONFORMING BEYOND REASONABLE CONSTRUCTION TOLERANCES, THEY SHALL BE BROUGHT INTO COMPLIANCE WITH THE CBC AS A PART OF THIS PROJECT BY MEANS OF A CONSTRUCTION CHANGE DOCUMENT."
- PATH OF TRAVEL (P.O.T.) AS INDICATED IS A BARRIER FREE ACCESS WITHOUT ANY ABRUPT VERTICAL CHANGES EXCEEDING 1/2" BEVELED AT 1:2 MAXIMUM SLOPE, EXCEPT THAT LEVEL CHANGES DO NOT EXCEED 1/4" VERTICAL AND IS AT LEAST 48" WIDE. SURFACE IS SLIP RESISTANT, STABLE, FIRM, AND SMOOTH. CROSS-SLOPE DOES NOT EXCEED 2% AND SLOPE IN THE DIRECTION OF TRAVEL IS LESS THAN 5% UNLESS OTHERWISE INDICATED. (P.O.T.) SHALL MAINTAIN FREE OF OVERHANGING OBSTRUCTIONS TO 80" MINIMUM (11B-307.4) AND PROTRUDING OBJECTS GREATER THAN 4" PROJECTION FROM THE WALL AND ABOVE 27" AND LESS THAN 80" (11B-204.5, 11B-307).
- CONTRACTOR TO VERIFY THAT ALL BARRIERS IN THE PATH OF TRAVEL HAVE BEEN REMOVED OR WILL BE REMOVED UNDER THIS PROJECT, AND PATH OF TRAVEL COMPLIES WITH CBC 11B-206.
- PROVIDE SITE DIRECTIONAL ACCESSIBLE ROUTE SIGNAGE (DS-1) AT ALL MAJOR JUNCTIONS PER CBC SEC. 11B-216.6
- REFER TO SHEET(S) AS 2 FOR EXIT SIGNAGE.
- DISTRICT HAS CLARIFIED THAT THERE IS NO STORAGE OF HAZARDOUS CHEMICALS OF ANY QUANTITY IN THIS BUILDING THEREFORE H- OCCUPANCY IS NOT REQUIRED.
- DISTRICT HAS CLARIFIED THAT CAMPUS POLICE SERVICE IS A CONTRACTED SERVICE AND IS NOT AN EMERGENCY DISPATCH CENTER, THEREFORE THE BUILDING IS NOT AN ESSENTIAL SERVICES BUILDING.
- THE DISTRICT HAS CLARIFIED THAT NO PERSONS WILL BE HELD IN THIS FACILITY, THEREFORE I-OCCUPANCY IS NOT REQUIRED.

SITE IMPROVEMENT PLANS FOR COMPTON COMMUNITY COLLEGE CAMPUS PUBLIC SAFETY BUILDING

GENERAL NOTES FOR GRADING

- ALL WORK SHALL CONFORM WITH THE "GREENBOOK" STANDARD SPECIFICATIONS FOR PUBLIC WORKS CONSTRUCTION (SSPWC), 2015 EDITION AND THE LATEST REVISIONS HERETO, THE WORK AREA TRAFFIC CONTROL HANDBOOK (W.A.T.C.H. MANUAL), A.D.A. TITLE 24 REQUIREMENTS, AND THE 2013 C.B.C. UNLESS SPECIFIED OTHERWISE IN THE CONTRACT SPECIFICATIONS.
- A COPY OF THE DIVISION OF STATE ARCHITECT APPROVED VERSION OF THESE PLANS MUST BE IN THE POSSESSION OF A RESPONSIBLE PERSON AND AVAILABLE AT THE JOB SITE AT ALL TIMES.
- AT LEAST TWO (2) WORKING DAYS PRIOR TO COMMENCING CONSTRUCTION, THE CONTRACTOR SHALL CONTACT THE REGIONAL NOTIFICATION CENTER (UNDERGROUND SERVICE ALERT OF SOUTHERN CALIFORNIA - U.S.A. AT 811) TO OBTAIN AN INQUIRY IDENTIFICATION NUMBER AND TO REQUEST THE UTILITY OWNERS TO MARK OR OTHERWISE INDICATE THE LOCATION OF THEIR SUBSURFACE FACILITIES. THE CONTRACTOR SHALL DETERMINE THE LOCATION AND DEPTH OF ALL UTILITIES, INCLUDING ALL SERVICE CONNECTIONS, WHICH HAVE BEEN MARKED BY THE RESPECTIVE OWNERS AND WHICH MAY AFFECT OR BE AFFECTED BY ITS OPERATIONS. THE CONTRACTOR SHALL TAKE ALL NECESSARY MEASURES TO PROTECT ALL UTILITIES AND ALL STRUCTURES FOUND AT THE SITE.
- THROUGHOUT ALL PHASES OF CONSTRUCTION, INCLUDING SUSPENSION OF WORK, UNTIL FINAL ACCEPTANCE OF THE PROJECT, THE CONTRACTOR SHALL KEEP THE WORK SITE CLEAN AND FREE FROM RUBBISH AND DEBRIS. THE CONTRACTOR SHALL ALSO ABATE DUST NUISANCE BY CLEANING, SWEEPING AND SPRINKLING WITH WATER AND USING DUST FENCES OR OTHER METHODS AS DIRECTED BY THE CONSTRUCTION MANAGER OR FIELD INSPECTOR THROUGHOUT THE CONSTRUCTION OPERATION.
- KEEP A RECORD OF CHANGES THAT OCCUR DURING CONSTRUCTION AND SUBMIT THIS RECORD TO THE OWNER CERTIFIED AS "RECORD DRAWING" PLANS.
- ALL DAMAGE CAUSED TO PUBLIC STREETS, INCLUDING HAUL ROUTES, ALLEYS, SIDEWALKS, CURBS OR STREET FURNISHINGS, OR TO PRIVATE PROPERTY SHALL BE REPAIRED AT THE SOLE EXPENSE OF THE CONTRACTOR TO THE PUBLIC WORKS INSPECTOR'S & THE PROJECT CIVIL ENGINEER'S SATISFACTION.
- THE CONTRACTOR SHALL REMOVE AND REPLACE ANY BROKEN OR DAMAGED SIDEWALK, CURB, GUTTER OR ASPHALT PAVING CAUSED BY THEIR WORK AT THE DIRECTION OF THE OWNER AT NO ADDITIONAL COST TO THE OWNER.
- TRIM TREE ROOTS AS NECESSARY TO CONSTRUCT PAVEMENT AND INSTALL HEADERS, TRIM ROOTS UNDER THE DIRECTION OF A CERTIFIED ARBORIST. THE DISTRICT OAK WILL NOTIFY THE DISTRICT GARDENING SUPERVISOR PRIOR TO TRIMMING ROOTS.
- UPON MOBILIZATION THE CONTRACTOR SHALL POTHOLE AND EXPOSE THE EXISTING UTILITIES AT ALL CROSSINGS AND AT THE POINT OF TIE-IN; THEN CONTACT THE ENGINEER TO VERIFY THE ELEVATION OF THE EXISTING FACILITIES.
- SURVEY MONUMENTS SHALL BE PRESERVED AND REFERENCED BEFORE CONSTRUCTION AND RE-PLACED AFTER CONSTRUCTION PURSUANT TO SECTION 2-9 OF THE STANDARD SPECIFICATIONS FOR PUBLIC WORKS CONSTRUCTION (SSPWC).
- EITHER WATER OR DUST PALMATIVE, OR BOTH, MUST BE APPLIED FOR THE ALLEVATION OR PREVENTION OF EXCESSIVE DUST RESULTING FROM THE LOADING OR TRANSPORTATION OF EARTH FROM OR TO THE PROJECT SITE OR PRIVATE AND PUBLIC ROADWAYS.
- CONSTRUCT STRAIGHT GRADES BETWEEN ELEVATIONS SHOWN ON PLAN UNLESS INTERRUPTED BY A GRADE CHANGE LINE. ANY DEVIATION FROM THE GRADING PLAN MUST HAVE PRIOR APPROVAL FROM THE ENGINEER.
- ALL AREAS TO RECEIVE COMPACTED FILL SHALL BE INSPECTED AND APPROVED BY THE SOILS ENGINEER (AND ENGINEERING GEOLOGIST, WHERE EMPLOYED) AFTER REMOVAL OF UNSUITABLE MATERIAL AND EXCAVATION OF KEYWAYS AND BENCHES, AND PRIOR TO PLACEMENT OF SUBSURFACE DRAINAGE SYSTEMS OR ANY FILLS.
- ALL SOILS OR ROCK MATERIALS DEEMED UNSUITABLE FOR PLACEMENT IN COMPACTED FILL SHALL BE REMOVED FROM THE SITE. ANY IMPORTED MATERIAL SHALL BE TESTED PER DISTRICT REQUIREMENTS AND APPROVED BY THE SCHOOL DISTRICT AND SOILS ENGINEER PRIOR TO USE IN COMPACTED FILL. BLOCKY MATERIAL SHALL BE BROKEN INTO SUITABLE PARTICLE SIZES, BEFORE BEING USED AS FILL IN CONFORMANCE OF THE PROJECT SOILS REPORT.
- ALL TREE ROOTS, ABANDONED IRRIGATION LINES, UTILITY SERVICES, SEPTIC TANKS AND SIMILAR MATERIALS SHALL BE REMOVED FROM THE SITE AND VOIDS CREATED THEREBY SHALL BE PROPERLY FILLED AND COMPACTED AS DIRECTED BY THE GEOTECHNICAL ENGINEER WITHIN THE LIMITS OF ALL OVER-EXCAVATED AREAS.
- ALL EXCAVATED BACK SLOPES AND KEYS FOR BUTTRESS FILLS MUST BE EXAMINED BY THE ENGINEERING GEOLOGIST AND SOILS ENGINEER TO INSURE ALL POTENTIAL PLANES OF FAILURE HAVE BEEN EXPOSED IN THE EXCAVATION AND WILL BE ADEQUATELY SUPPORTED BY THE PROPOSED BUTTRESS FILLS.
- THE SOILS ENGINEER SHALL SUBMIT RECOMMENDATIONS FOR CORRECTIVE WORK TO INSURE SLOPE STABILITY WHERE UNSTABLE MATERIAL IS EXPOSED AT THE TOP OF CUTS. COORDINATE WITH ARCHITECT OF RECORD AND OWNERS REPRESENTATIVE.
- THE CONTRACTOR SHALL BE RESPONSIBLE FOR PROVIDING STORM DAMAGE PREVENTION MEASURES OR EROSION CONTROL DEVICES AND/OR TO PERFORM CERTAIN GRADING TO PREVENT SOIL OR EXCESS RUNOFF FROM FLOWING INTO PUBLIC STREETS OR ADJACENT PROPERTIES. IN THE EVENT OF SUCH AN OCCURRENCE, CLEANUP SHALL COMMENCE IMMEDIATELY. SHOULD CITY FORCES OR THE CITY CONTRACTOR PERFORM ANY CLEANUP RESULTING FROM THIS DEVELOPMENT, THE CONTRACTOR SHALL PAY THE COST INCURRED WITHIN TEN (10) WORKING DAYS UPON RECEIPT OF BILLING.
- THE CONTRACTOR OR HIS AGENT SHALL BE RESPONSIBLE FOR REMOVAL AND CLEANUP OF ANY SPILL ON PUBLIC STREETS DURING THE GRADING OPERATION, AS WELL AS REPAIR OF DAMAGE TO HAUL ROUTES AND EXISTING FACILITIES.
- MAXIMUM SLOPES FOR BOTH CUT AND FILL SHALL BE 2:1.
- NO OVERSIZE OR OVERWEIGHT LOADS ARE PERMITTED WITHOUT A SEPARATE MOVING PERMIT.
- ALL EQUIPMENT USED TO HAUL EXCAVATION OR FILL MATERIAL FROM OR TO THE SITE SHALL FOLLOW A DESIGNATED ROUTE OR ROUTES IN GOING TO AND FROM THE SITE. THE CONTRACTOR SHALL BE ENTITLED TO THE DESIGNATION OF A ROUTE PROVIDING ACCESS TO A SPECIFIED PLACE OTHER THAN THE SITE, AFTER SHOWING TO THE SATISFACTION OF THE CITY BUILDING OFFICIAL THAT SUCH SPECIFIED PLACE IS A PLACE WHERE EXCAVATION MATERIAL MAY BE REASONABLY DEPOSITED OR FILL MATERIAL MAY BE OBTAINED. A SEPARATE ENCROACHMENT PERMIT IS REQUIRED WHEN IT IS NECESSARY TO FLAG TRAFFIC OR INSTALL ANY TRAFFIC CONTROL DEVICES NO CITY RIGHT-OF-WAY.
- FINE GRADING TO BE NO LESS THAN THE FOLLOWING UNLESS STATED OTHERWISE ON THE PLANS:

	CROSS-SLOPE	LONGITUDINAL-SLOPE
PERVIOUS SURFACES	2.00%	1.00%
ASPHALT SURFACES	1.00%	1.00%
CONCRETE SURFACES	0.50%	0.50%
- THE CONTRACTOR SHALL NOTIFY THE DSA INSPECTOR AND OWNERS REPRESENTATIVE AT LEAST 48 HOURS IN ADVANCE OF REQUIRED INSPECTIONS AT FOLLOWING STAGES OF THE WORK:
 - (A) INITIAL: WHEN THE SITE HAS BEEN CLEARED OF VEGETATION AND UNAPPROVED FILL AND IT HAS BEEN SCARIFIED, BENCHMARK OR OTHERWISE PREPARED FOR FILL. NO FILL SHALL HAVE BEEN PLACED PRIOR TO THIS INSPECTION.
 - (B) ROUGH: WHEN APPROXIMATE FINAL ELEVATIONS HAVE BEEN ESTABLISHED; DRAINAGE TERRACES, SWALES AND BERMS INSTALLED AT THE TOP OF THE SLOPES.
 - (C) FINAL: WHEN GRADING HAS BEEN COMPLETED; ALL DRAINAGE DEVICES INSTALLED; SLOPE PLANTING ESTABLISHED, IRRIGATION SYSTEMS INSTALLED AND THE RECORD PLANS, REQUIRED STATEMENTS, AND REPORTS HAVE BEEN SUBMITTED.
- ANY EARTH ROCK, GRAVEL, SAND, STONE OR OTHER EXCAVATED MATERIAL DEPOSITED OR CAUSED TO FLOW OR WASH UPON ANY PUBLIC OR PRIVATE PROPERTY SHALL BE REMOVED FROM SUCH PUBLIC PLACE OR PRIVATE PROPERTY BY THE END OF THE WORKDAY BY THE CONTRACTOR RESPONSIBLE FOR THE DEPOSITION. IF AN ADVERSE CONDITION IS CAUSED BY DEPOSIT, THE CONDITION SHALL BE CORRECTED IMMEDIATELY.
- EVERY EFFORT SHOULD BE MADE TO ELIMINATE THE DISCHARGE OF NON-STORMWATER FROM THE PROJECT SITE AT ALL TIMES.
- ALL TRUCKS HAULING DIRT, SAND, OIL, OR OTHER LOOSE MATERIALS ON A HIGHWAY ARE TO BE COVERED OR SHOULD MAINTAIN AT LEAST TWO FEET OF FREEBOARD IN ACCORDANCE WITH THE REQUIREMENTS OF CALIFORNIA VEHICLE CODE SECTION 23114. (FREEBOARD MEANS VERTICAL SPACE BETWEEN THE TOP OF THE LOAD AND TOP OF THE TRAILER).
- RAISE UTILITY BOXES TO ULTIMATE FINISH SURFACE IN SCOPE OF WORK AREAS.
- CONTRACTOR SHALL HIRE A LICENSED SURVEYOR TO STAKE ALL CATCH BASINS, STORM DRAIN PIPE, SAW-CUT LINES, BUILDING PADS, FINISH FLOORS, SWALES AND GRADE BREAKS. TWO STAKES SHALL BE PROVIDED FOR ALL CATCH BASINS.
- IN ORDER TO MITIGATE THE IMPACTS ON CULTURAL RESOURCES OR LANDSCAPING, IF CULTURAL MATERIAL, SUGGESTIVE OF PREHISTORIC OR HISTORIC ORIGIN IS ENCOUNTERED, WORK IN THE VICINITY OF THE FIND SHALL BE STOPPED, AND THE OWNER SHALL BE NOTIFIED. GRADING, CONSTRUCTION OR LANDSCAPING SHALL NOT RESUME UNTIL THE FIND IS EVALUATED AND IT IS DETERMINED WHETHER THE MATERIAL IS ARCHAEOLOGICALLY SIGNIFICANT AND ADDITIONAL MITIGATION IS REQUIRED.
- NO PERSON SHALL, WHEN HAULING ANY EARTH, SAND, GRAVEL, ROCK, STONE OR OTHER EXCAVATED MATERIAL OR DEBRIS OVER ANY PUBLIC STREET, ALLEY OR OTHER PUBLIC PLACE, ALLOW SUCH MATERIAL TO BLOW OR SPILL OVER UPON SUCH STREET, ALLEY OR PUBLIC PLACE OR ADJACENT PRIVATE PROPERTY OR ANY WATER BODIES, CREEKS OR STREAMS. THE CONTRACTOR SHALL BE RESPONSIBLE FOR THE CLEANUP AND REMOVAL OF ANY CONSTRUCTION OR SOILS MATERIALS DEPOSITED ON THE PUBLIC RIGHT-OF-WAY, PUBLIC WATERS OR ADJACENT PRIVATE PROPERTY.

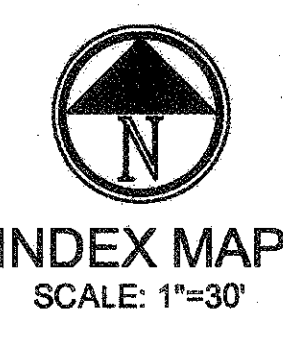
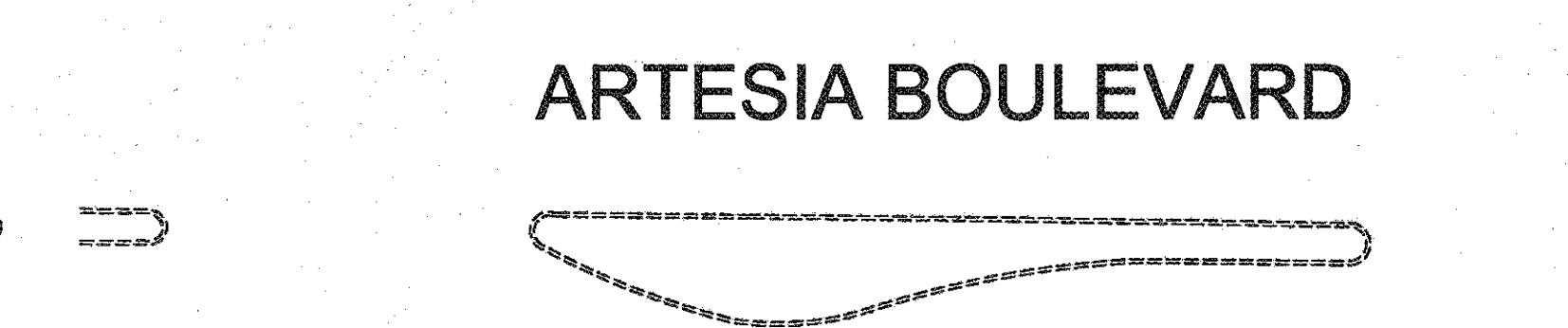
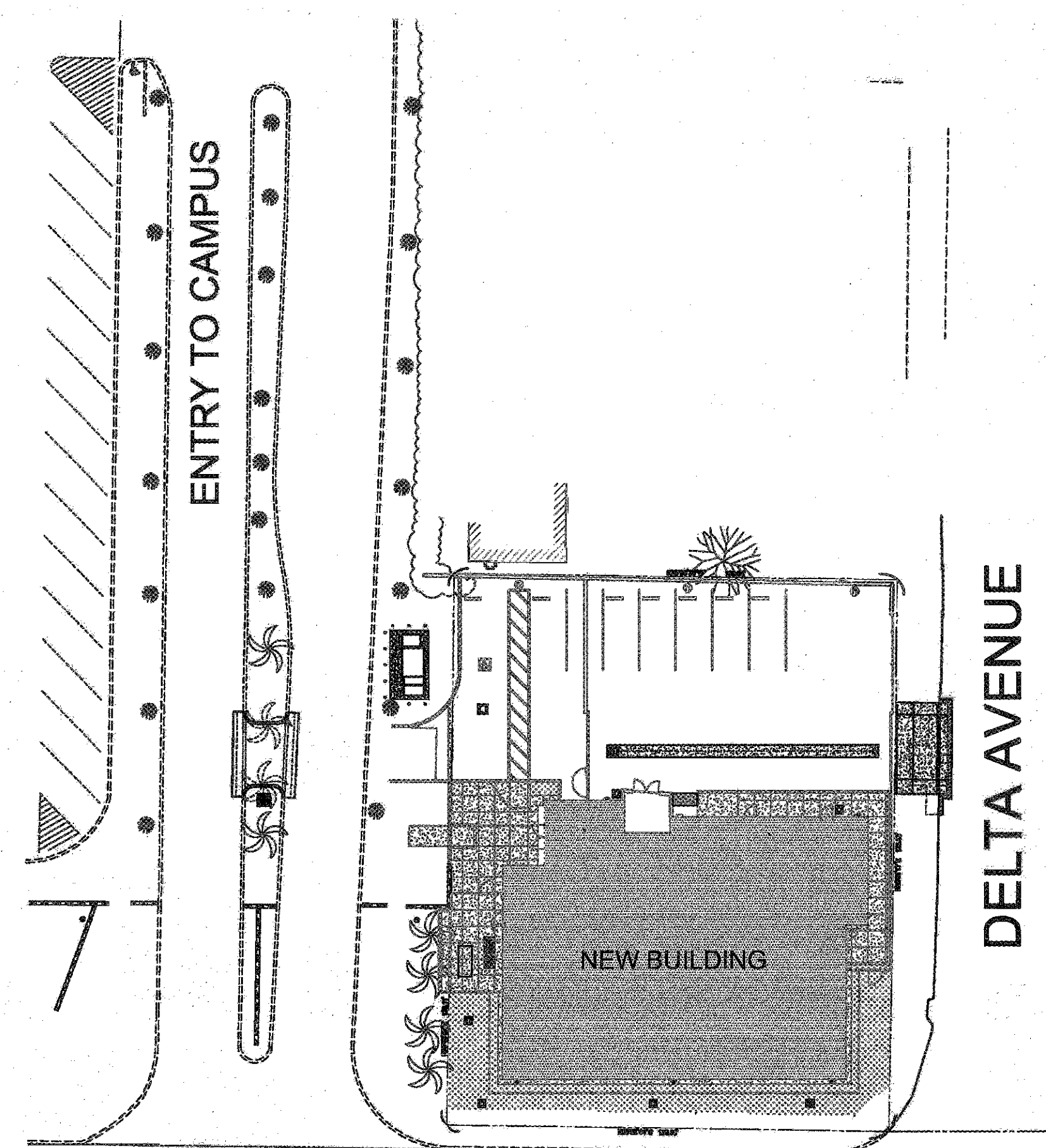

SHEET INDEX

SHEET	DESIGNATION
CT.0	SITE IMPROVEMENT PLAN TITLE SHEET
CT.1	GRADING PLAN
CT.2	GRADING DETAIL SHEET
CT.3	GRADING DETAIL SHEET

HORIZONTAL CONTROL

AN AUTOCAD GEOMETRIC CONSTRUCTION FILE SHALL BE MADE AVAILABLE TO THE CONTRACTOR UPON REQUEST FOR THE CONTRACTOR'S SURVEYOR TO LAYOUT THE CONSTRUCTION STAKING OF THE PROJECT. THE SURVEYOR OR CONTRACTOR WILL NEED TO SIGN A WAIVER FORM BEFORE RELEASE OF ANY CAD ELECTRONIC DRAWINGS.

BENCH MARK INFORMATION:

ADD 0.08 FEET TO ELEVATION SHOWN HEREON TO EQUAL THE LOS ANGELES COUNTY DEPARTMENT OF PUBLIC WORKS 2005 ADJUSTMENT OF THE NORTH AMERICAN DATUM OF 1988 (NAV088) PER THE FOLLOWING LOS ANGELES COUNTY BENCHMARKS:

GARDENA QUAD, 2005 ADJUSTMENT:

LA COUNTY DPW BM Y12223 2005 ADJ. ELEV. = 63.473' NAV088 PER COUNTY ELEV.=63.39 PER THIS SURVEY (HENNON & AERIAL MAP) L&DPW TAG IN EAST CURB 1 FT. NORTH OF BEGINNING OF CURB RETURN AT NORTHEAST CORNER OF ALAMEDA STREET (EAST BARRREL) AND GREENLEAF BLVD. LA COUNTY DPW BM Y12222 2005 ADJ. ELEV.=63.496' NAV088 PER COUNTY ELEV.=63.42' PER THIS SURVEY (HENNON & AERIAL MAP) L&DPW TAG IN EAST CURB 1 FT. SOUTH OF BEGINNING OF CURB RETURN AT SOUTHEAST CORNER ALAMEDA STREET (EAST BARRREL) & GREENLEAF BLVD.

ANY USER OF ELEVATION AND/OR COORDINATES SHOWN HEREON FOR THE CONTROL OF CONSTRUCTION, SHALL VERIFY AT LEAST 3 POINTS SHOWN HEREON, FOR MATHEMATICAL CONSISTENCY PRIOR TO SUCH USE.

EXISTING UNDERGROUND STRUCTURES

THE LOCATIONS OF THE EXISTING UNDERGROUND UTILITIES, AS SHOWN ON THESE PLANS, WERE OBTAINED FROM SOURCES OF VARYING RELIABILITY, NO REPRESENTATION IS MADE AS TO THE ACCURACY OR COMPLETENESS OF SAID UTILITY INFORMATION. THE CONTRACTOR IS CAUTIONED THAT ONLY ACTUAL EXCAVATION WILL REVEAL THE LOCATIONS OF SUCH UNDERGROUND UTILITIES. CONTRACTOR SHALL VERIFY LOCATIONS OF EXISTING UTILITIES PRIOR TO ANY EXCAVATION OR IMPROVEMENT. THE CONTRACTOR SHALL TAKE PRECAUTIONARY MEASURES TO PROTECT THE UTILITY LINES SHOWN TO BE PROTECTED HEREON AND ANY OTHER LINES NOT OF RECORD OR NOT SHOWN HEREON.

EARTHWORK NOTICE TO CONTRACTOR: NO EARTHWORK ANALYSIS HAS BEEN COMPLETED WITH RESPECT TO VOLUMES OF SOILS TO BE EXCAVATED, PLACED, OR IMPORTED IN ORDER TO PROVIDE THE FINISHED GRADES SHOWN ON THE PLANS. THE CONTRACTOR IS SOLELY RESPONSIBLE FOR VERIFYING THE EARTHWORK QUANTITIES NECESSARY TO COMPLETE THE PROJECT.

**FOR WORK WITHIN, OR NEAR,
THE PUBLIC RIGHT-OF-WAY**

Underground Service Alert

CALL: 811

TWO WORKING DAYS BEFORE YOU DIG

GENERAL NOTES TO CONTRACTOR

- THE CONTRACTOR'S ATTENTION IS DIRECTED TO SECTION 7-10, PUBLIC CONVENIENCE AND SAFETY, OF THE STANDARD SPECIFICATIONS FOR PUBLIC WORKS CONSTRUCTION (GREENBOOK), IN REGARDS TO SAFETY ORDERS.
- SCOPE OF WORK:
 - A. FURNISH ALL LABOR, SUPERVISION, MATERIALS, EQUIPMENT & FACILITIES NECESSARY TO FURNISH, FABRICATE, DELIVER, STORE AND INSTALL ALL WORK NOTED ON THE DRAWINGS.
 - B. THE CONTRACTOR SHALL FURNISH & INSTALL ALL WORK NECESSARY TO MAKE A COMPLETE SYSTEM WHETHER OR NOT SUCH DETAILS ARE MENTIONED IN THESE SPECIFICATIONS OR SHOWN ON THE PLANS, BUT WHICH ARE OBVIOUSLY NECESSARY TO MAKE A COMPLETE SYSTEM, EXCEPTING ONLY THOSE PORTIONS THAT ARE SPECIFICALLY MENTIONED HEREIN OR PLAINLY MARKED ON THE ACCOMPANYING DRAWINGS AS BEING INSTALLED UNDER ANOTHER SECTION OF THE SPECIFICATION.
- IT SHALL BE THE CONTRACTORS RESPONSIBILITY TO VERIFY AVAILABLE SPACES FOR INSTALLING THE WORK.
- COORDINATION: THE DRAWINGS ARE DIAGRAMMATIC & INTENDED TO SHOW SCOPE, CONTRACTOR SHALL COORDINATE HIS WORK WITH OTHER TRADES TO PROVIDE BEST ARRANGEMENT OF ALL DUCT, PIPES, CONDUIT, ETC.
- WORKMANSHIP: THE WORK SHALL BE ACCOMPLISHED BY THE USE OF COMPETENT MECHANICS SKILLED IN THEIR TRADE. THE ENGINEER AND ARCHITECT SHALL HAVE THE RIGHT TO INTERPRET COMPLIANCE OF WORKMANSHIP WITH THE CONTRACT DOCUMENTS.
- MATERIALS: ALL MATERIALS, APPLIANCES & EQUIPMENT SHALL BE NEW & THE BEST OF THEIR RESPECTIVE KIND, FREE FROM ALL DEFECTS AND OF THE MAKE, BRAND, AND QUANTITY SPECIFIED.
- CLEAN-UP: UPON COMPLETION OF THE WORK UNDER THIS SECTION THE CONTRACTOR SHALL REMOVE ALL SURPLUS MATERIALS, EQUIPMENT & DEBRIS INCIDENTAL TO THIS WORK & LEAVE THE PREMISES CLEAN AND ORDERLY.

RECOMMENDATIONS AND CONCLUSIONS OF SOILS REPORT No. 1529-CR, DATED OCTOBER 24, 2016 BY GEOTEK, INC. SHALL BE THOROUGHLY COMPLIED WITH. WHERE CONFLICTING INFORMATION BETWEEN THIS GRADING PLAN AND/OR THE PROJECT EARTHWORK SPECIFICATIONS & THE MENTIONED REPORT OCCUR, NOTIFY THE OWNER.

GRADING PLANS, DRAINAGE IMPROVEMENTS, ROAD AND ACCESS REQUIREMENTS AND ENVIRONMENTAL HEALTH CONSIDERATIONS SHALL COMPLY WITH ALL LOCAL ORDINANCES.

LEGEND

<ul style="list-style-type: none"> ● POWER POLE ○ SEWER MANHOLE ○ STORM DRAIN MANHOLE ○ TELEPHONE MANHOLE ○ FIRE HYDRANT ○ SEWER CLEANOUT ○ WATER VALVE ○ GAS VALVE ○ WATER METER ○ GAS METER ○ WATER VAULT ○ GAS VAULT ○ TELEPHONE VAULT ○ ELECTRIC VAULT ○ WELL ○ ELECTRIC PULLBOX ○ GUY WIRE ○ LIGHT (58.00) EXISTING ELEVATION 58.00 PROPOSED ELEVATION - - - - - = EXISTING CONTOURS — — — — = PROPOSED CONTOUR 	<ul style="list-style-type: none"> △ SIGN POST — WIRE FENCE — CHAIN LINK FENCE — BLOCK WALL ☼ TREE ● SURVEY MONUMENT → FLOW DIRECTION — EDGE OF PAVEMENT FS FINISHED SURFACE FF FINISHED FLOOR FL FLOW LINE CF CURB FACE GB GRADE BREAK HP HIGH POINT INV INVERT SD STORM DRAIN W DOMESTIC WATER S SANITARY SEWER G GAS E ELECTRICAL/POWER COMMUNICATIONS
--	---

DEPTHS SHOWN ARE APPROXIMATE. ESTIMATED DEPTHS ARE FROM THE GROUND SURFACE TO THE CENTER OF THE FACILITY. INVERT OF WASTE LINES, OR TO THE FACILITY TRACER WIRE. DEPTH ESTIMATES SHOULD BE USED WITH CAUTION AND MAY VARY ALONG THE LENGTH OF THE FACILITY.

ABBREVIATIONS

ABND ABANDONED	L T & T LEAD TACK AND TAG
AC ASPHALT PAVEMENT	MH MANHOLE
AP ANGLE POINT	NG NATURAL GROUND
BLDG BUILDING	N.I.C. NOT IN CONTRACT
BC BEGINNING OF CURVE	P.C.C. PORTLAND CEMENT CONCRETE
BW BACK OF WALK	PL PROPERTY LINE
CL CENTERLINE	PIV POST INDICATOR VALVE
CF CURB FACE HEIGHT	PP POWER POLE
CLF CHAIN LINK FENCE	RCE REGISTERED CIVIL ENGINEER
CONC CONCRETE	RR RAILROAD
DCV DETECTOR CHECK VALVE	S SLOPE
DESC DESCRIBED	SDMH STORM DRAIN MANHOLE
D/W DRIVEWAY	SL STREET LIGHT
DS DOWN SPOUT	SMH SEWER MANHOLE
EP EDGE OF PAVEMENT	S.P.P.W.C. STANDARD PLANS FOR PUBLIC WORKS CONSTRUCTION (LATEST EDITION).
EC END OF CURVE	S.S.P.W.C. STANDARD SPECIFICATIONS FOR PUBLIC WORKS CONSTRUCTION (GREEN BOOK), 2015 EDITION
EX EXISTING	
FDC FIRE DEPARTMENT CONNECTION	
FDH FIRE HYDRANT	SW SIDEWALK
FL FLOWLINE	TC TOP OF CURB
FS FINISH SURFACE	TELE TELEPHONE
GA GUY ANCHOR	TG TOP OF GRATE
GB GRADE BREAK	TCO TOP OF CLEANOUT
GP GUARD POST	TS TRAFFIC SIGN
GV GAS VALVE	TW TOP OF WALL
HB HOSE BIBB	TYP TYPICAL
HP HIGH POINT	UDG UNDERGROUND CONDUIT
ICV IRRIGATION CONTROL VALVE	UTL UTILITY
INV INVERT	WM WATER METER
IP IRON PIPE	WV WATER VALVE
L LENGTH	W VLT WATER VAULT
LIP LIP OF GUTTER	VIF VERIFY IN FIELD
LP LIGHT POLE	VLT VAULT

FLOOD ZONE INFORMATION

Per Flood Insurance Rate Map Number 06037C1B15F, dated September 26, 2008, the flood zone for this area is **ZONE X (SHADED)**. ZONE X (SHADED) is an area of 0.2% (500-year) annual chance flood; areas of 1% (100-year) annual chance flood with average depths of less than 1 foot or with drainage areas less than 1 square mile and areas protected by levees from a 1% (100-year) annual chance flood.

Date: July 12, 2016
To: Division of State Architect, DSA
From: David Dent, Chief Building Official
Re: Compton Community College Swing Space Project - Flood Zone

To whom it may concern,

Most of Compton has been identified to be in flood **Zone X (Unshaded)** or **Zone X (Shaded)**. These areas have no base flood elevations and are protected from the base flood by a credited flood protection system. The City of Compton does not require new projects in these zones to be built with specific design considerations to protect them from a possible flood. The City of Compton does not require the finish floor of a building to be elevated above a base flood elevation in these zones. The City of Compton does not require special foundations (such as concrete versus wood) for new projects based on if they are in a Zone X (shaded) or Zone X (unshaded).

Sincerely,
David Dent
Chief Building Official

205 S. Willowbrook Avenue, Compton, CA 90220 * (310) 605-5509 * (310) 605-5598

LITTLE

DIVERSIFIED ARCHITECTURAL CONSULTING

1300 Dove Street, Suite 100
Newport Beach, CA 92660
T: 949.698.1400 F: 949.698.1433

www.littleonline.com

This drawing and the design shown are the property of Little Diversified Architectural Consulting. The reproduction, copying or other use of this drawing without their written consent is prohibited and any infringement will be subject to legal action.

© Little 2016

COMPTON
CCD

CAMPUS PUBLIC SAFETY BUILDING

1111 EAST ARTESIA BOULEVARD,
COMPTON CALIFORNIA 90221

IDENTIFICATION STAMP
DIV. OF THE STATE ARCHITECT
OFFICE OF REGULATION SERVICES

FILE NO: 19-C1
APR. 03-117673
DATE DEC. 1 2 2017

CONTRACTOR: **FPL and Associates, Inc.**
Traffic-Transportation-Civil-CAD
30 Corporate Park, Suite 401
Irvine, CA 92606
Phone: 949-252-1668

PROJECT TEAM
PRINCIPAL IN CHARGE: RC
PROJECT MANAGER: RC
DRAWN BY: AL
DESIGNED: NO

TITLE SHEET

913-4675-00

12/01/16 C1.0

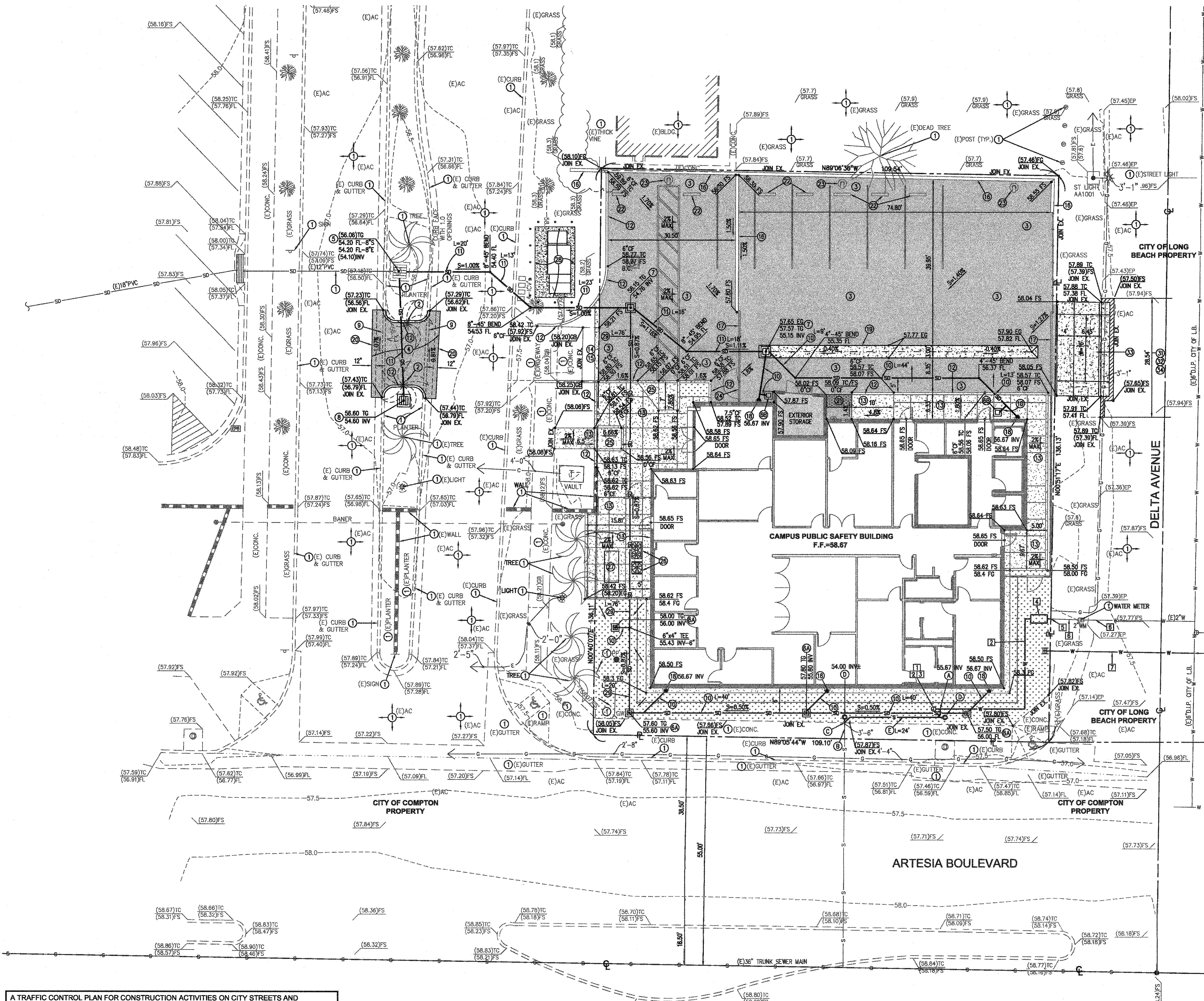

- ### CONSTRUCTION NOTES
- PROTECT EXISTING IMPROVEMENTS IN PLACE.
 - REMOVE EXISTING PALM TREE & ROOTS.
 - CONSTRUCT ASPHALT PAVEMENT SECTION (LIGHT DUTY) PER TABLE 1, ON SHEET C1.2.
 - CONSTRUCT ASPHALT PAVEMENT SECTION (HEAVY DUTY) PER TABLE 1, ON SHEET C1.2.
 - BREAK INTO EXISTING CATCH BASIN AND INSTALL NEW PIPE.
 - CONSTRUCT 12" SQUARE CATCH BASIN PER DETAIL 6A ON SHEET C1.2. INSTALL WITH GALVANIZED FRAME & STEEL GALVANIZED GRATE (PARKWAY RATED, A.D.A. BOLT-DOWN TYPE).
 - CONSTRUCT 12" SQUARE CATCH BASIN PER DETAIL 6B ON SHEET C1.2. INSTALL WITH GALVANIZED FRAME & STEEL GALVANIZED GRATE (PARKWAY RATED, A.D.A. BOLT-DOWN TYPE).
 - CONSTRUCT 12" SQUARE CATCH BASIN PER DETAIL 6C ON SHEET C1.2. FRAME & STEEL GALVANIZED GRATE (TRAFFIC RATED STEEL COVER).
 - CONSTRUCT 18" SQUARE CATCH BASIN PER DETAIL 7 ON SHEET C1.2. INSTALL WITH GALVANIZED FRAME & STEEL GALVANIZED GRATE (TRAFFIC RATED, A.D.A. BOLT-DOWN TYPE).
 - CONSTRUCT 24" SQUARE CATCH BASIN PER DETAIL 8 ON SHEET C1.2. INSTALL QUICCAST STORMWATER SOLUTIONS FLOGARD CATCH BASIN INSERT FILTER GRATED INLET STYLE MODEL FFP-24FB OR APPROVED EQUAL.
 - REMOVE EXISTING CURBS & GUTTER.
 - CONSTRUCT 4" SDR-35 P.V.C. DRAINAGE PIPE. SEE CORRESPONDING TRENCH DETAILS ON SHEET C1.2.
 - CONSTRUCT 8" SDR-35 P.V.C. DRAINAGE PIPE. SEE CORRESPONDING TRENCH DETAILS ON SHEET C1.2.
 - CONSTRUCT 4" THICK CONCRETE SIDEWALK PER DETAIL 13 ON C1.2.
 - REMOVE EXISTING CONCRETE.
 - CONSTRUCT 6" THICK CONCRETE OVER 4" CRUSHED AGGREGATE BASE.
 - CONSTRUCT MASONRY WALL PER STRUCTURAL PLANS.
 - CONSTRUCT STEEL ROLLING GATE PER ARCHITECTURAL PLANS.
 - CONNECT UNDERGROUND STORM DRAIN TO ROOF DRAIN DOWNSPOUT WITH FERROD COUPLING OR APPROVED EQUAL.
 - CONSTRUCT 3" WIDE CONCRETE SWALE PER DETAIL 19 ON SHEET C1.2.
 - SAW CUT EXISTING ASPHALT PAVEMENT WITH CLEAN EDGE.
 - CONSTRUCT DETECTABLE WARNINGS PER ARCHITECTURAL PLANS.
 - CONSTRUCT WHEEL STOPS PER DETAIL 6 ON SHEET A1.3.1.
 - CONSTRUCT SITE LIGHTING PER ELECTRICAL PLANS.
 - CONSTRUCT GATE PER ARCHITECTURAL PLANS.
 - CONSTRUCT ACCESSIBLE CURB RAMP PER GRADES HEREON AND DETAILS ON ARCHITECTURAL PLANS.
 - CONDENSER UNIT PER SHEET E1.1.1.
 - EMERGENCY GENERATOR ENCLOSURE PER SHEET E1.1.1.
 - NEW PAD MOUNTED SUB-STATION PER SHEET E1.1.1.
 - CONSTRUCT 6" SDR-35 P.V.C. DRAINAGE PIPE. SEE CORRESPONDING TRENCH DETAILS ON SHEET C1.2.

- ### CONSTRUCTION NOTES IN CITY OF LONG BEACH RIGHT-OF-WAY
- PROTECT EXISTING IMPROVEMENTS IN PLACE.
 - REMOVE EXISTING CONCRETE DRIVEWAY APPROACH.
 - REMOVE EXISTING 12" WIDE ASPHALT CONCRETE PAVEMENT IN STREET.
 - CONSTRUCT 4" THICK CONCRETE DRIVEWAY PER CITY OF LONG BEACH STANDARD PLAN No. 105, MODIFIED TYPE 1 (2'-3" W-16") ON C1.3.
 - REPLACE EXISTING ASPHALT PAVEMENT SECTION PER CITY OF LONG BEACH STANDARD PLAN No. 116 ON C1.3.

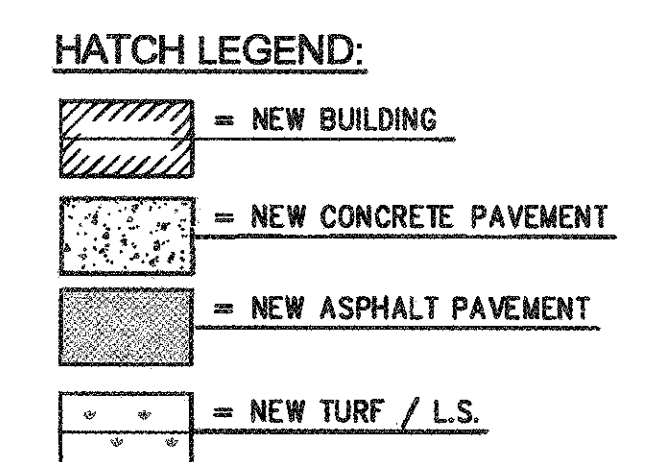

NOTE: STRAIGHT GRADES SHALL BE CONSTRUCTED BETWEEN SPOT ELEVATIONS OR CONTOURS INDICATED, EXCEPT WHERE GRADE BREAKS INTERVENE.

NOTE: CONSTRUCTION TOLERANCES DO NOT PERMIT THE VARIATION OF DIMENSIONS OR GRADES AND SLOPES AND THEIR RELATIONSHIPS REQUIRED BY CODE. ADJUST WORK AS REQUIRED TO COMPLY WITH SUCH REQUIREMENTS.

NOTE: CONTRACTOR IS REQUIRED TO RESTORE ALL EXISTING IMPROVEMENTS TO THE SAME CONDITION, THAT ARE NOT PART OF THIS PROJECT, THAT EXISTED PRIOR TO HIS STARTING CONSTRUCTION.

CONSTRUCTION STORM WATER NOTE:
GRADING WORK ASSOCIATED WITH THIS PROJECT WILL DISTURB LESS THAN 1 ACRE OF SOIL AND THUS SHALL NOT BE SUBJECT TO COMPLY WITH THE NPDES STORMWATER CONSTRUCTION GENERAL PERMIT 2009-0009-DWQ.

NOTE: CONTRACTOR SHALL BOLT DOWN ALL NEW GRATES TO FRAME FOR ANTI-THEFT PURPOSES AFTER CONSTRUCTION IS COMPLETED.

SEE ARCHITECTURAL PLANS FOR ALL STRIPING IMPROVEMENTS SHOWN HEREON.

A TRAFFIC CONTROL PLAN FOR CONSTRUCTION ACTIVITIES ON CITY STREETS AND SIDEWALKS MUST BE PREPARED AND SUBMITTED TO THE CITY OF LONG BEACH FOR REVIEW AND APPROVAL AS A PART OF THIS PROJECT BY THE CONTRACTOR. THE TRAFFIC CONTROL PLAN SHALL BE DRAWN TO SCALE AND SHALL DELINEATE THE EXISTING CURBS AND TRAFFIC STRIPING. ALL TRAFFIC CONTROL WORK SHALL CONFORM TO THE LATEST CALTRANS TRAFFIC MANUAL (CHAPTER 5 - MANUAL OF TRAFFIC CONTROL) AND THE LATEST WORK AREA TRAFFIC CONTROL HANDBOOK (WATCH MANUAL). TRAFFIC CONTROL PLAN MUST BE APPROVED BY THE CITY PRIOR TO THE ISSUANCE OF A PERMIT.

NOTE TO CONTRACTOR: NO CONSTRUCTION OR EXCAVATION WORK IS ALLOWED WITHIN THE CITY OF LONG BEACH RIGHT-OF-WAY (WHICH INCLUDES THE SIDEWALK AND PARKWAY) WITHOUT AN ENCROACHMENT PERMIT, OBTAINED FROM THE PUBLIC WORKS DEPARTMENT. TO OBTAIN A PERMIT YOU MUST BE A LICENSED AND INSURED CONTRACTOR.

- ### WATER CONSTRUCTION NOTES
- SEE PLUMBING PLANS FOR CONTINUATION OF WATER LINE INTO BUILDING.
 - CONSTRUCT 2" SCH. 80 PVC PIPE, FITTINGS AND COUPLINGS. SEE CORRESPONDING TRENCH DETAIL ON SHEET C1.2.
 - CONSTRUCT 2" WATER SHUT-OFF VALVE PER DETAIL 2 ON SHEET C1.3.
 - CONSTRUCT 2" BACKFLOW PREVENTER PER DETAIL 4 ON C1.3.
 - CONNECT TO EXISTING WATER LINE WITH APPROPRIATE FITTINGS.
 - PROTECT EXISTING WATER IMPROVEMENT IN PLACE.
 - LONG BEACH WATER DEPARTMENT SHALL INSTALL 1" WATER SERVICE INSTALLATION & METER PER LMD DTD. PLAN NO. WDS-001 AND PROVIDE TRENCH RESTORATION PER LMD WDS-406. CONTRACTOR SHALL DO ALL WORK DOWNSTREAM OF METER.

- ### SEWER CONSTRUCTION NOTES
- SEE PLUMBING PLANS FOR CONTINUATION INTO BUILDING.
 - PROTECT EXISTING SEWER IMPROVEMENT IN PLACE.
 - CONNECT TO EXISTING 4" SEWER LINE WITH APPROPRIATE FITTINGS.
 - CONSTRUCT SEWER CLEAN-OUT & YARD BOX PER DETAIL 'D' ON SHEET C1.3.
 - CONSTRUCT 4" SDR-35 PVC SEWER PIPE. SEE CORRESPONDING TRENCH DETAIL ON SHEET C1.2.

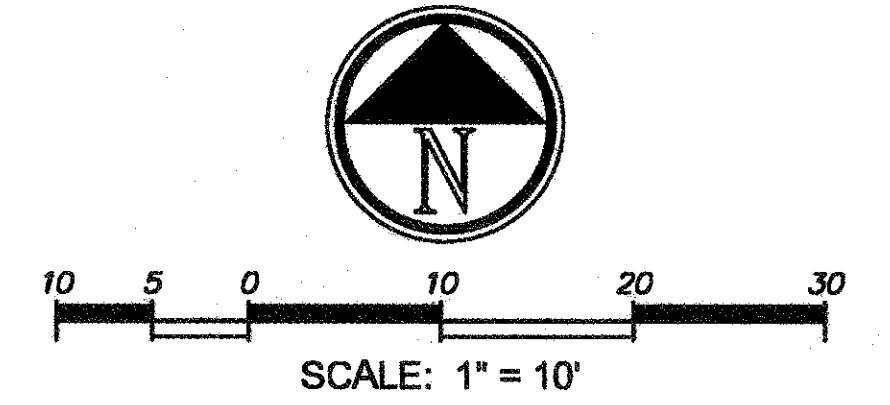

1300 Dove Street, Suite 100
Newport Beach, CA 92660
T: 949.698.1400 F: 949.698.1433
www.littleonline.com

This drawing and the design shown are the property of Little Diversified Architectural Consulting. The reproduction, copying or other use of this drawing without their written consent is prohibited and any infringement will be subject to legal action.

© Little 2016

COMPTON CCD

PROJECT NAME

CLIENT NAME

CAMPUS PUBLIC SAFETY BUILDING

1111 EAST ARTESIA BOULEVARD,
COMPTON CALIFORNIA 90221

DESIGN REVIEW

IDENTIFICATION STAMP
DIV. OF THE STATE ARCHITECT
OFFICE OF REGULATION SERVICES

FILE NO: 19-C1
AR: 03-117873

AC: [Signature] FLS: [Signature] SS: [Signature]
DATE: DEC 12 2017

CONTRACTOR

FPL and Associates, Inc.
Traffic - Transportation - Civil - CAD
30 Corporate Park, Suite 401
Irvine, CA 92606
Phone: 949-250-1988

PROJECT TEAM

PRINCIPAL IN CHARGE: RC

PROJECT MANAGER: RC

DRAWN BY: AL

REVISIONS

NO	REASON	DATE

GRADING PLAN

PROJECT NUMBER

913-4675-00

ISSUE DATE

12/01/16

SHEET NO.

C1.1

TRENCH EXCAVATION, BEDDING, & BACKFILL NOTES:

EXCAVATION NOTE: EXCAVATION 5.0 FEET AND DEEPER SHALL BE SUPPORTED AS SET FORTH IN THE RULES, ORDERS AND REGULATIONS OF THE CALIFORNIA DEPARTMENT OF INDUSTRIAL RELATIONS, DIVISION OF INDUSTRIAL ACCIDENTS. THE CONTRACTOR SHALL SUBMIT A DETAIL SHOWING THE DESIGN OR SHORING, BRACING, SLOPING OR OTHER PROVISIONS TO BE MADE FOR WORKER PROTECTION FROM THE HAZARDS OF CAVING GROUND DURING THE EXCAVATION. THE PLAN SUBMITTED SHALL BE SIGNED BY A REGISTERED CIVIL OR STRUCTURAL ENGINEER CERTIFIED THAT THE PLAN COMPLIES WITH ALL OSHA CONSTRUCTION SAFETY ORDERS.

BEDDING MATERIAL SHALL BE COARSE SAND WITH SAND EQUIVALENT OF 30 OR GREATER. NO ANGULAR STONES OR PEA GRAVELS WILL BE ALLOWED IN PIPE BEDDING.

BEDDING & BACKFILL SHALL BE PLACED IN ACCORDANCE WITH SECTION 306-1.2.1 AND 306-1.3 OF THE "STANDARD SPECIFICATIONS FOR PUBLIC WORKS CONSTRUCTION (S.S.P.W.C.), LATEST EDITION" AND AS SUPPLEMENTED HEREIN. TRENCH BACKFILL SLURRY PER SECTION 201-1, EXISTING SITE SOILS, WHERE CONDITIONS DICTATE HEREIN, ARE CONSIDERED SUITABLE FOR BACKFILLING OF UTILITY TRENCHES PROVIDED THEY ARE FREE OF DEBRIS, PARTICLES GREATER THAN 4 INCHES IN MAXIMUM DIMENSION, ORGANIC MATTER OR OTHER DELETERIOUS MATERIALS. EXTREME CARE SHALL BE TAKEN TO AVOID DAMAGE TO CONDUITS, PIPES, AND ANY APPURTENANCES. PER SECTION 306-1.2.1 OF S.S.P.W.C., IF SOFT, SPONGY, UNSTABLE OR OTHER UNSUITABLE MATERIAL IS ENCOUNTERED UPON WHICH THE BEDDING MATERIAL OR PIPE IS TO BE PLACED, THIS MATERIAL SHALL BE REMOVED TO A DEPTH ORDERED BY THE CIVIL ENGINEER AND REPLACED WITH BEDDING MATERIAL SUITABLY DENSIFIED.

COMPACTION METHODS: ALL BEDDING & BACKFILL COMPACTION SHALL BE BY HAND-OPERATED, PLATE-TYPE, VIBRATORY, OR OTHER SUITABLE HAND-TAMPERS IN AREAS NOT ACCESSIBLE TO LARGER ROLLERS OR COMPACTORS. EXTREME CARE SHALL BE TAKEN TO AVOID DAMAGE TO CONDUITS, PIPES, AND ANY APPURTENANCES. WATER DENSIFICATION BY INUNDATION OR JETTING SHALL NOT BE PERMITTED WITHOUT PRIOR WRITTEN APPROVAL FROM CIVIL ENGINEER.

SHEETING: WHEN EXCAVATION DEPTHS OR SOIL CONDITIONS REQUIRE SHORING OR USE OF A TRENCH BOX, THE BOTTOM OF THE SHORING OR TRENCH BOX SHOULD BE PLACED NO LOWER THAN THE TOP OF THE PIPE. THIS PREVENTS DISRUPTION OF THE BACKFILL ENVELOPE WHEN REMOVING THE SHORING OR TRENCH BOX. IF THIS PRACTICE CANNOT BE FOLLOWED, CONSIDERATION SHOULD BE GIVEN TO LEAVING THE SHORING IN PLACE.

WARNING TAPE NOTES (ON-SITE WATER):

A METALLIC LINED TAPED FOR UNDERGROUND PIPES, MARKED "CAUTION BURIED WATER LINE BELOW", IN POLYETHYLENE FILM COLOR BLUE, INSTALLED ABOVE PIPE, 6" WIDE.

WARNING TAPE NOTES (ON-SITE STORM DRAIN):

A METALLIC LINED TAPED FOR UNDERGROUND PIPES, MARKED "CAUTION STORM DRAIN LINE BELOW", IN POLYETHYLENE FILM COLOR GREEN, INSTALLED ABOVE PIPE, 6" WIDE.

WARNING TAPE NOTES (ON-SITE SEWER):

A METALLIC LINED TAPED FOR UNDERGROUND PIPES, MARKED "CAUTION BURIED SEWER LINE BELOW", IN POLYETHYLENE FILM COLOR GREEN, INSTALLED ABOVE PIPE, 6" WIDE.

TRACER WIRE NOTES:

COPPER TRACER WIRE SHALL BE INSTALLED ON ALL NON-METALLIC PIPELINES JUST ABOVE THE HORIZONTAL CENTERLINE OF THE PIPE. THE COPPER WIRE SHALL BE THIN, #12 AWG GAUGE, WITH HEAT AND MOISTURE RESISTANT INSULATION.

ON-SITE TRENCHING DETAILS - STORM DRAINS, SEWER & WATER LINES

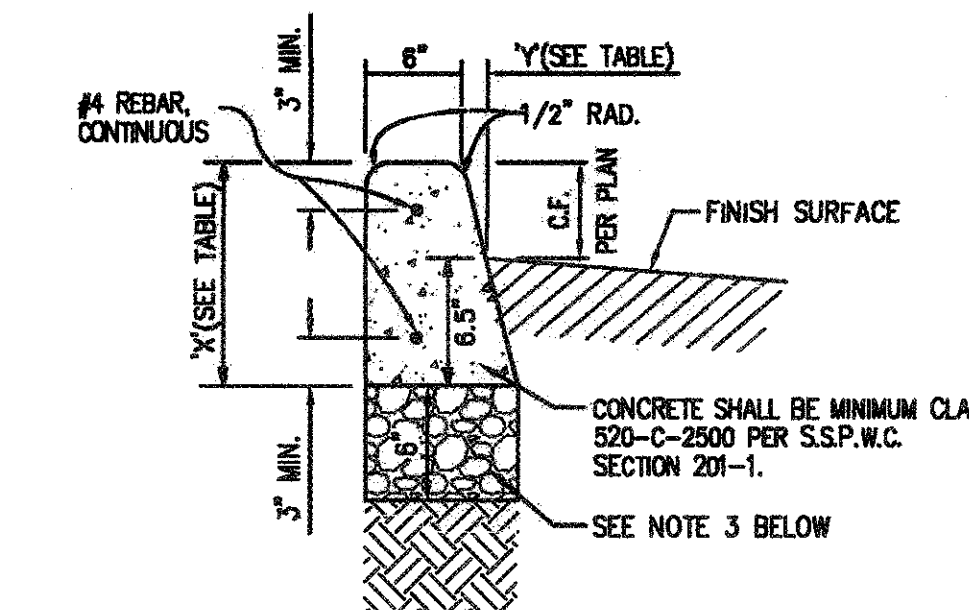
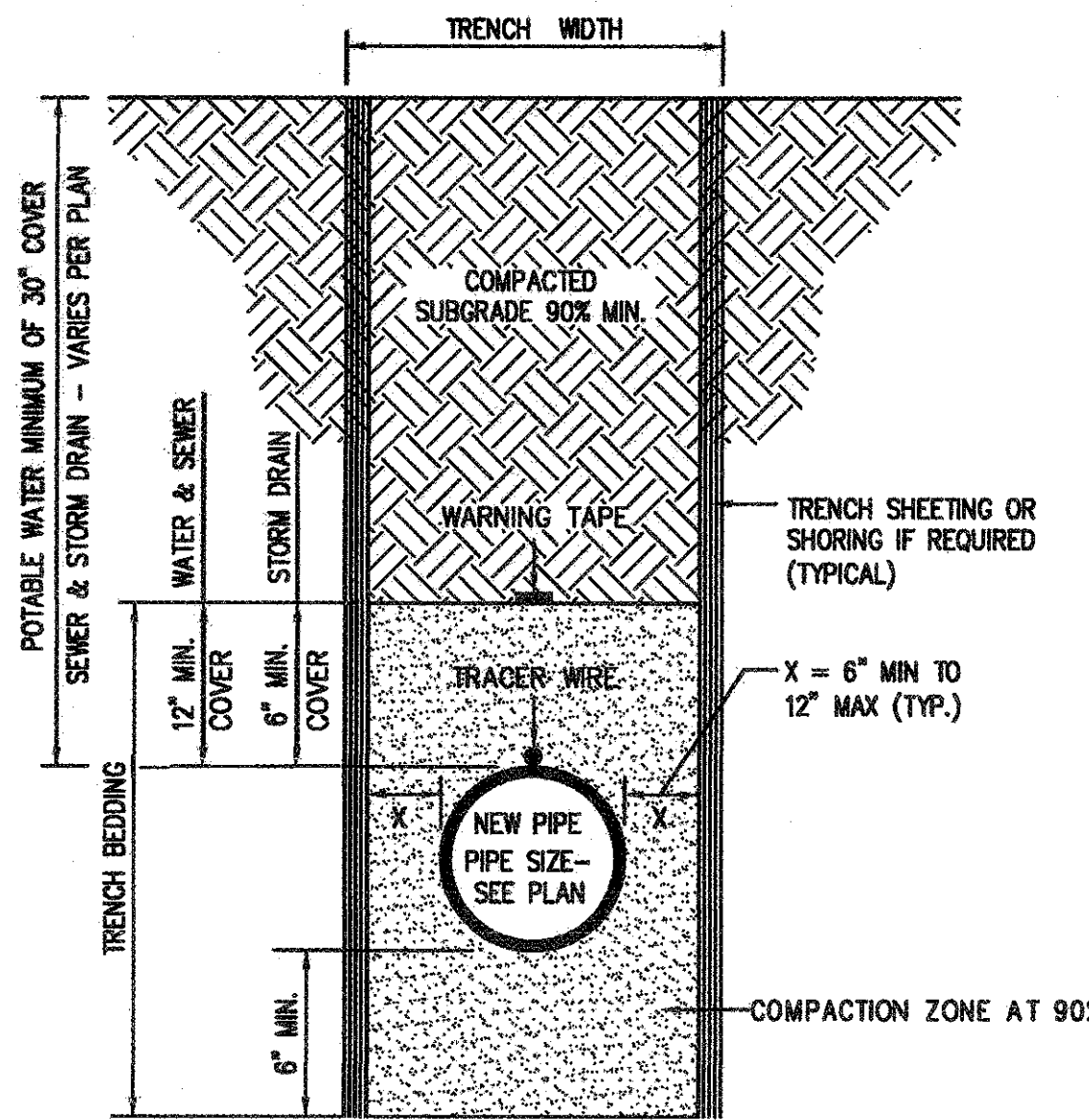

CONCRETE CURB DETAIL NOT TO SCALE

CURB FACE	0"	4"	5"	6"	8"	9"
X	6.5"	10.5"	11.5"	12.5"	14.5"	15.5"
Y	0"	1"	1.25"	1.5"	2"	2"

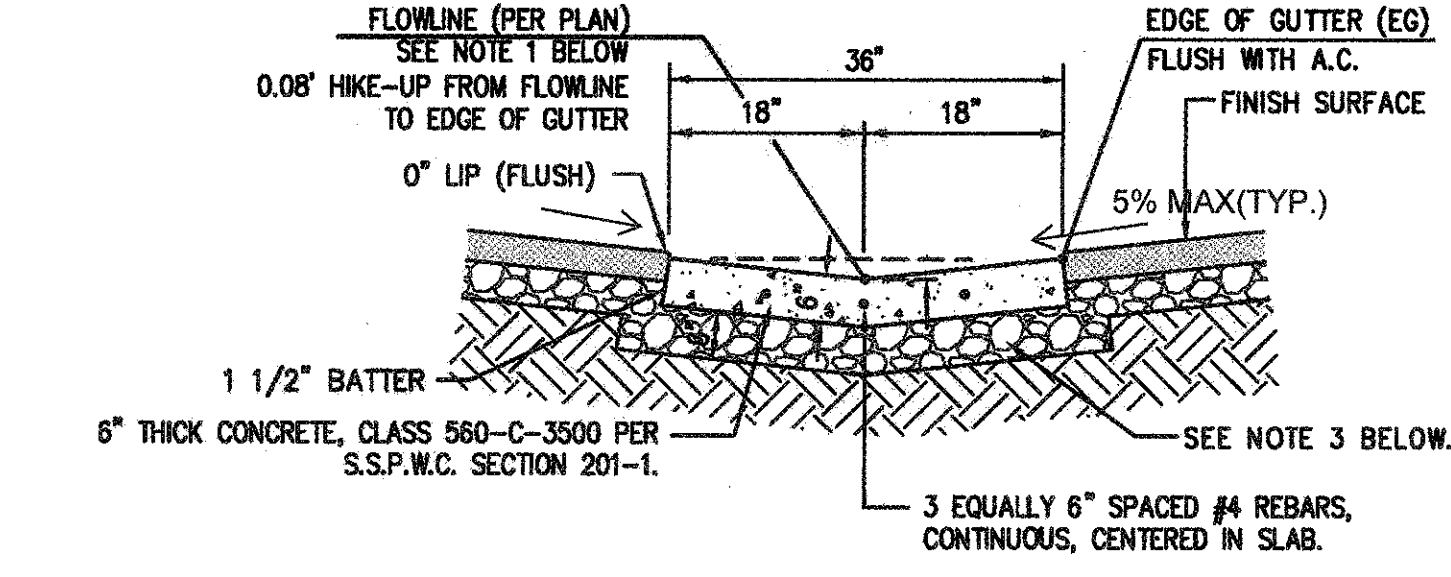

- CONCRETE SWALE NOTES:**
- CONCRETE SWALE SHALL HAVE AN 4" WIDE FLOWLINE SMOOTH STEEL TROWEL FINISH.
 - CONSTRUCT CONTROL JOINTS IN SWALE AT REGULAR INTERVALS OF 10'.
 - CONSTRUCT EXPANSION JOINTS WITH REBAR IN SWALE AT REGULAR INTERVALS OF 30'. CONSTRUCT EXPANSION JOINTS WITHOUT REBAR IN SWALE WHERE SWALE ABUTS CONCRETE, PLUS ALL B.C. & E.C.'S.
 - A 6" THICK LAYER OF CRUSHED AGGREGATE BASE MATERIAL SHALL BE PLACED UNDER THE SWALE. MINIMUM COMPACTION OF 95% RELATIVE DENSITY IS REQUIRED.
 - CROSS-SLOPE MUST NOT EXCEED 2% AND SLOPE IN THE DIRECTION OF TRAVEL MUST BE LESS THAN 5% IN AREAS DEFINED AS A PUBLIC WALKING SURFACE.

- GENERAL NOTES:**
- ALL EXPOSED EDGES SHALL HAVE A 1/2" RADIUS.
 - CONTROL JOINTS SHALL BE PLACED IN CURBS AT REGULAR INTERVALS OF 10'. EXPANSION JOINTS AT 30' INTERVALS, AND AT DRIVE APPROACHES, B.C.'S, E.C.'S, CROSS GUTTERS AND CATCH BASIN TRANSITIONS.
 - A 6" THICK LAYER OF CRUSHED BASE MATERIAL SHALL BE PLACED UNDER ALL CURB. MINIMUM COMPACTION OF 90% ON SUBGRADE AND 95% ON AGGREGATE BASE IS REQUIRED.
 - CONCRETE CURB SHALL BE MINIMUM CLASS 520-C-2500 PER S.S.P.W.C. SECTION 201-1.
 - PLACE CONTINUOUS #4 REBARS, 3" MINIMUM FROM TOP AND 3" MINIMUM FROM BOTTOM OF CURB.

TABLE 1 ASPHALT CONCRETE PAVEMENT STRUCTURAL SECTION

USAGE TYPE	STRUCTURAL SECTION
3 LIGHT DUTY	3" THICK ASPHALT OVER 4" THICK CRUSHED BASE
4 HEAVY DUTY	4" THICK ASPHALT OVER 6" THICK CRUSHED BASE

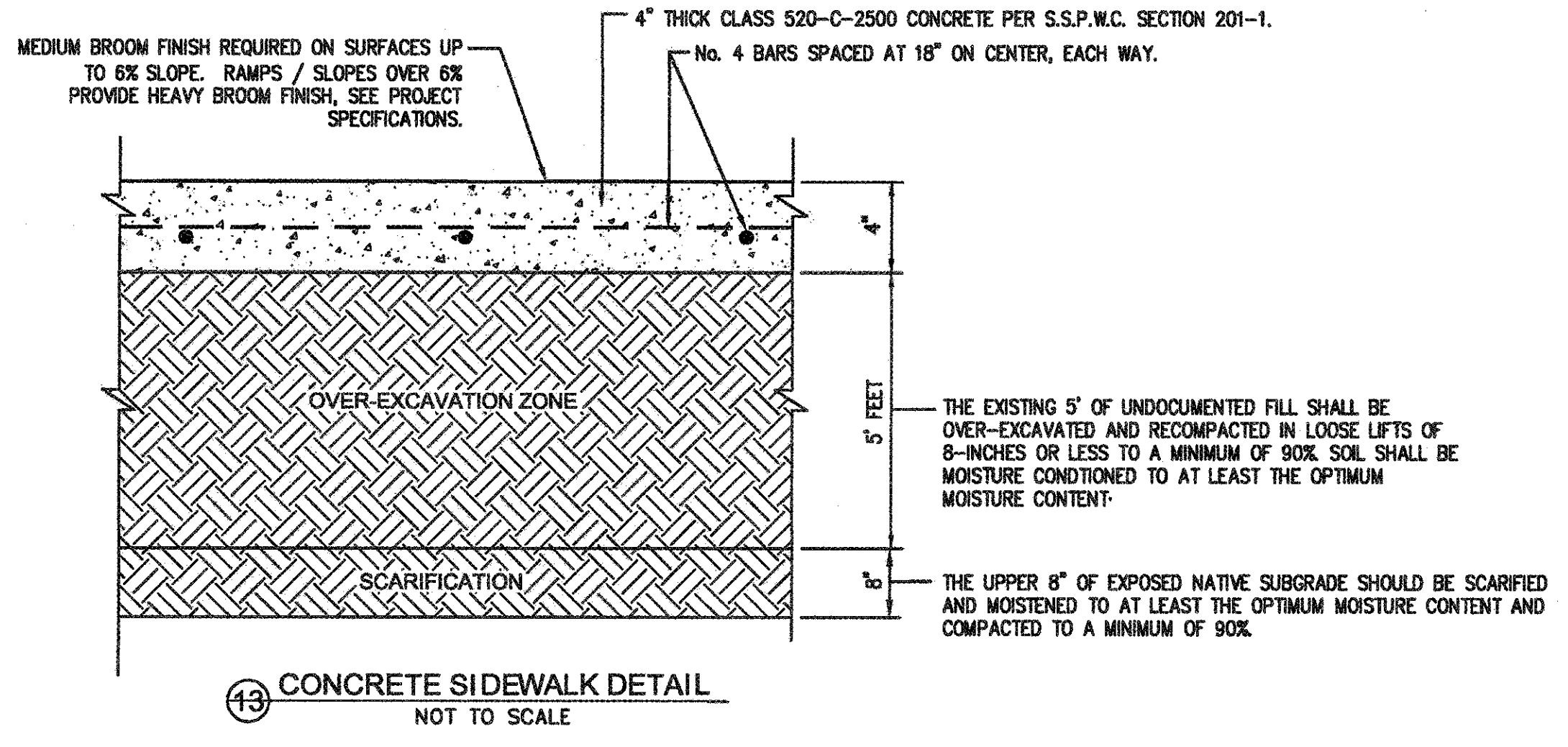
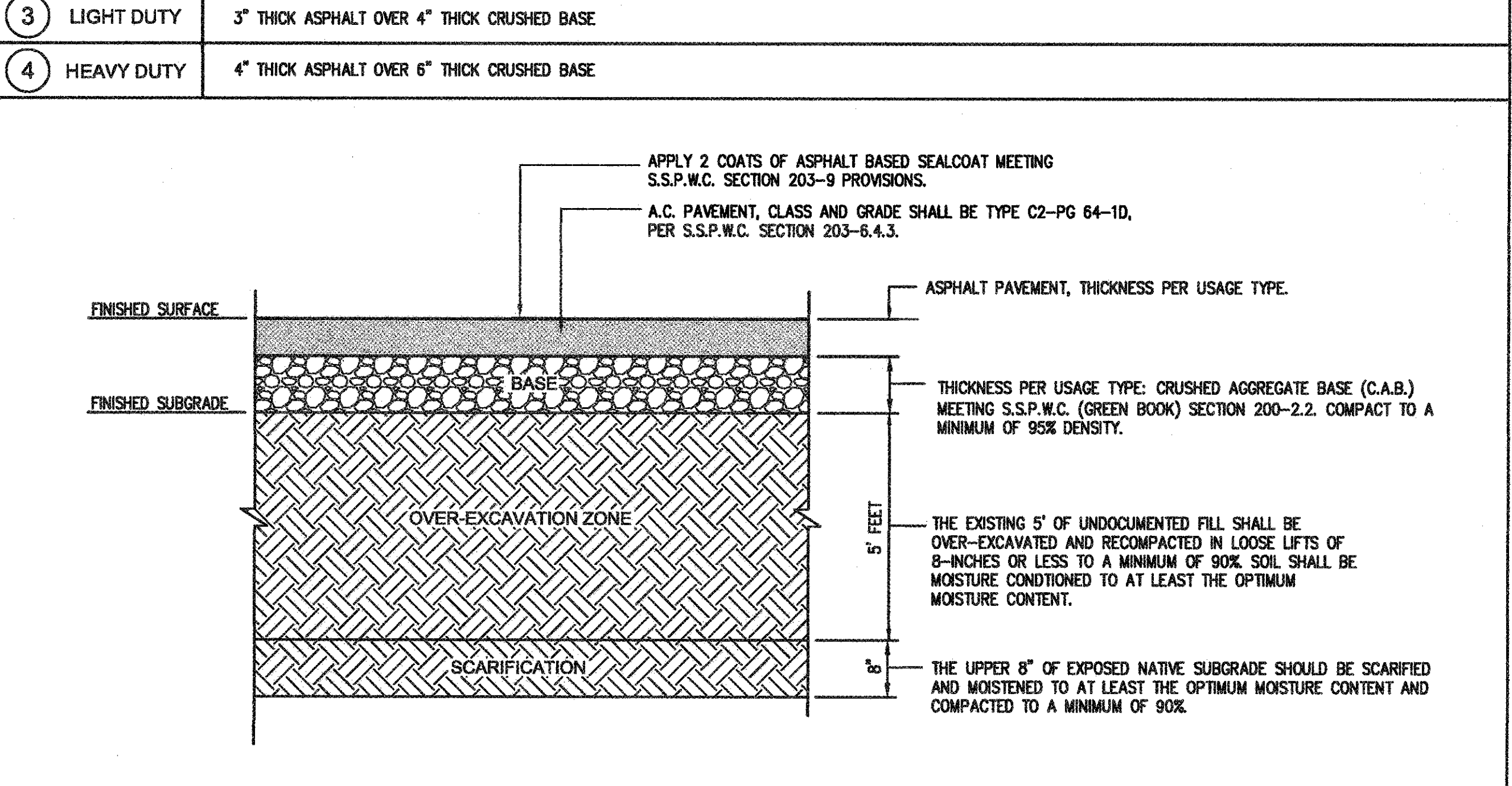

- CONCRETE SIDEWALK DETAIL NOT TO SCALE**
- NOTES:**
- MEDIUM BROOM FINISH REQUIRED ON WALK SURFACES UP TO 6% SLOPE.
 - ADJACENT PAVING, WHERE OCCURS, TO BE FLUSH WITH TOP EDGE OF SLAB.
 - ALL CONCRETE WALKS SHALL BE ASTM C-150 TYPE II PORTLAND CEMENT.
 - ALL CONCRETE WALKS SHALL BE 1" MAXIMUM COARSE AGGREGATE SIZE CONFORMING TO GRADING 'C' OF THE S.S.P.W.C. SECTION 201-1.3.2.A).

1212 CAST IRON GRATE
PARKWAY ONLY 28 lbs.
TRAFFIC 18 lbs.

1212 STEEL GRATES
PARKWAY 16 lbs.
TRAFFIC 18 lbs.

1212 STEEL COVER
PARKWAY 22 lbs.
TRAFFIC 25 lbs.

1212 TOP SECTION (WITH GALVANIZED FRAME)

1212 LOWER SECTION (NO FRAME)
NOTE: USE 12", 18", 24", 28" LOWERS TO INCREASE DEPTH UP TO A MAXIMUM OF 72"

1212 BASE
WT. 165 lbs.

TOP SECTION	HT.	LBS.	KNOCK-OUT
1212 T6	6"	170	NONE
1212 T12	12"	275	(4) 6" x 10"
1212 T18	18"	270	(4) 8" x 12"
1212 T24	24"	430	(4) 8" x 16"
1212 T28	28"	380	(4) 8" x 22"

EXTENSION SECTION	HT.	LBS.	KNOCK-OUT
1212 E6	6"	170	NONE

LOWER SECTION	HT.	LBS.	KNOCK-OUT
1212 L12	12"	275	(4) 6" x 10"
1212 L18	18"	270	(4) 8" x 12"
1212 L24	24"	430	(4) 8" x 16"
1212 L28	28"	380	(4) 8" x 22"

12" x 12" CATCH BASIN DETAIL
NOT TO SCALE

1818 CAST IRON GRATE
PARKWAY ONLY 58 lbs.
TRAFFIC 49 lbs.

1818 STEEL GRATES
PARKWAY 27 lbs.
TRAFFIC 49 lbs.

1818 STEEL COVER
PARKWAY 44 lbs.
TRAFFIC 66 lbs.

1818 TOP SECTION (WITH GALVANIZED FRAME)

1818 LOWER SECTION (NO FRAME)
NOTE: USE 12", 18", 24" LOWERS TO INCREASE DEPTH UP TO A MAXIMUM OF 72"

1818 BASE
WT. 270 lbs.

TOP SECTION	HT.	LBS.	KNOCK-OUT
1818 T6	6"	215	NONE
1818 T12	12"	370	(4) 8" x 10"
1818 T18	18"	585	(4) 8" x 11"
1818 T24	24"	785	(4) 8" x 11"

EXTENSION SECTION	HT.	LBS.	KNOCK-OUT
1818 E6	6"	215	NONE

LOWER SECTION	HT.	LBS.	KNOCK-OUT
1818 L12	12"	370	(4) 8" x 10"
1818 L18	18"	585	(4) 8" x 11"
1818 L24	24"	785	(4) 8" x 11"

18" x 18" CATCH BASIN DETAIL
NOT TO SCALE

2424 CAST IRON GRATE
PARKWAY 112 lbs.
TRAFFIC 103 lbs.

2424 STEEL GRATES
PARKWAY 48 lbs.
TRAFFIC 103 lbs.

2424 STEEL COVER
PARKWAY 81 lbs.
TRAFFIC 114 lbs.

2424 TOP SECTION (WITH GALVANIZED FRAME)

2424 LOWER SECTION (NO FRAME)
NOTE: USE 12", 18", 24" LOWERS TO INCREASE DEPTH UP TO A MAXIMUM OF 72"

2424 BOTTOM SECTION (WITH OR WITHOUT FRAME)

TOP SECTION	HT.	LBS.	KNOCK-OUTS
2424 T6	6"	270	NONE
2424 T12	12"	495	(6) 6" x 11"
2424 T18	18"	745	(4) 9" x 12"
2424 T24	24"	970	(4) 14" x 14"

EXTENSION SECTION	HT.	LBS.	KNOCK-OUTS
2424 E6	6"	270	NONE

LOWER SECTION	HT.	LBS.	KNOCK-OUTS
2424 L12	12"	495	(6) 6" x 11"
2424 L18	18"	745	(4) 9" x 12"
2424 L24	24"	970	(4) 14" x 14"

BOTTOM SECTION	HT.	LBS.	KNOCK-OUTS
2424 B30	36"	1995	(4) 18" x 18"
2424 B36	36"	1995	(4) 18" x 18"

24" x 24" CATCH BASIN DETAIL
NOT TO SCALE

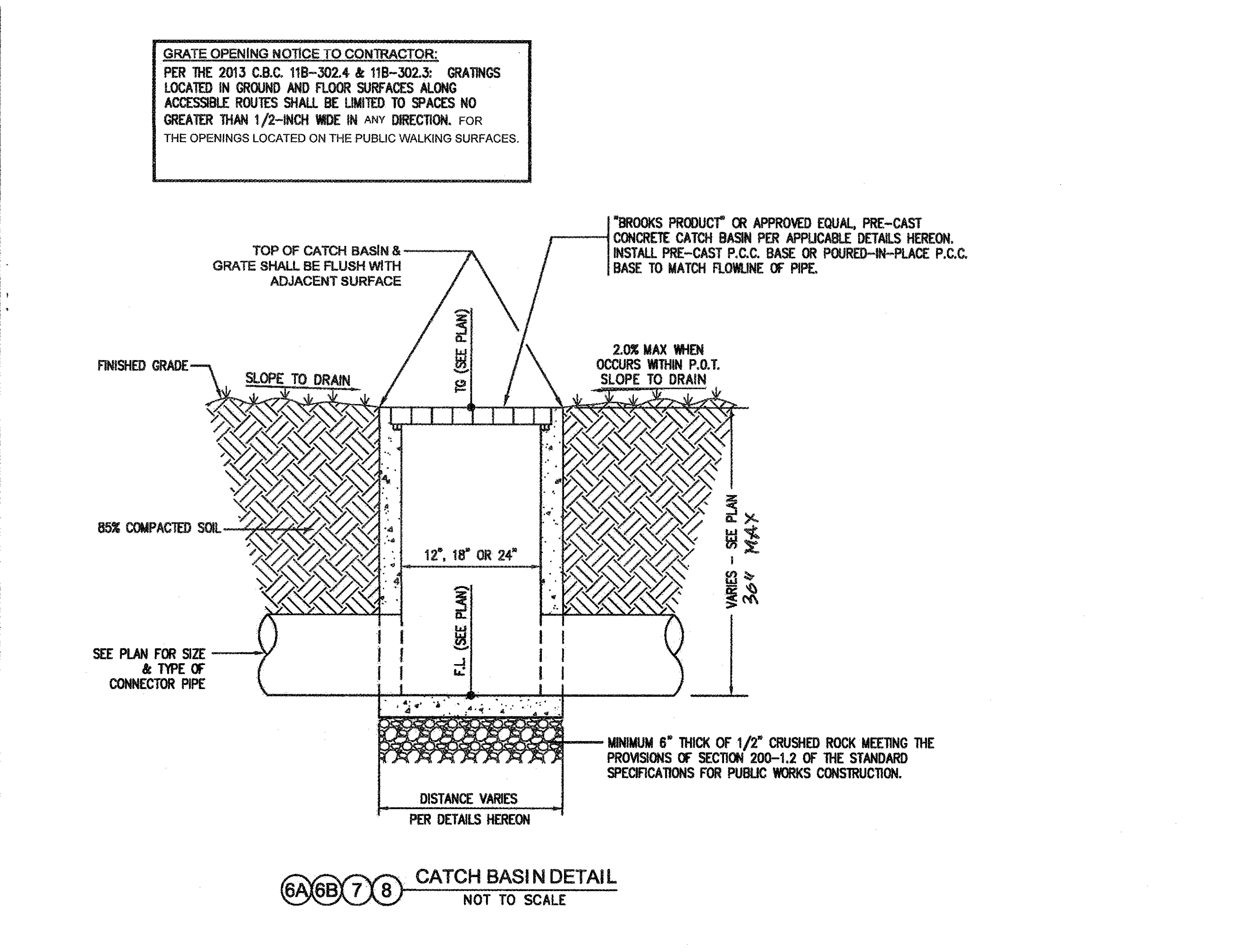

LITTLE
DIVERSIFIED ARCHITECTURAL CONSULTING

1300 Dove Street, Suite 100
Newport Beach, CA 92660
T: 949.698.1400 F: 949.698.1433
www.littleonline.com

This drawing and its design are the property of Little Diversified Architectural Consulting. The reproduction, copying or other use of this drawing without their written consent is prohibited and any infringement will be subject to legal action.

© Little 2016

COMPTON CCD

CAMPUS PUBLIC SAFETY BUILDING
1111 EAST ARTESIA BOULEVARD,
COMPTON CALIFORNIA 90221

IDENTIFICATION STAMP
DIV. OF THE STATE ARCHITECT
OFFICE OF REGULATION SERVICES
FILE NO. 19-C1
AR. 03-117673
AC. [Signature] FL. [Signature] 788
DATE DEC 12 2017

FPL and Associates, Inc.
Traffic - Transportation - Civil - CAD
30 Corporate Park, Suite 401
Irvine, CA 92606
Phone: 949-250-1988

PROJECT TEAM
PRINCIPAL IN CHARGE: RC
PROJECT MANAGER: RC
DRAWN BY: AL
REVISIONS: NO REASON DATE

GRADING DETAIL SHEET

913-4675-00

12/01/16 C1.2

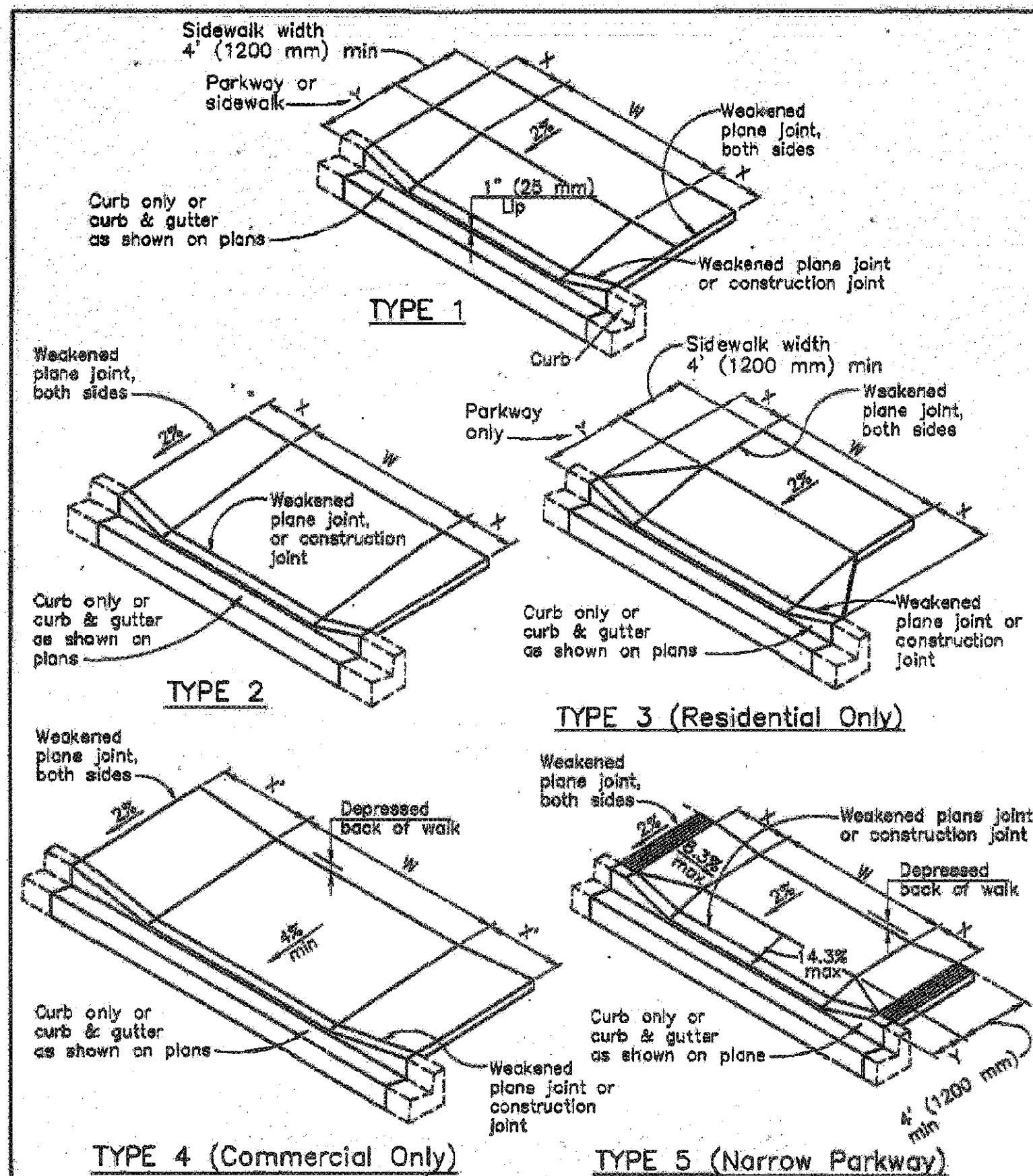

For allowed use of Type 2 and 4, see notes, sheet 3. Dimensions are in millimeters, except as noted.

REVISIONS	CITY OF LONG BEACH, CALIFORNIA	STANDARD PLAN NO.
NO. DATE	DEPARTMENT OF PUBLIC WORKS	
07/10/02	DRIVEWAYS	105
12/23/02		
03/02/06	APPROVED BY: <i>Paul A. Duff</i> DATE: 4/13/10	SHEET
11/10/10	CITY ENGINEER R.E. No. 42988	1 OF 3

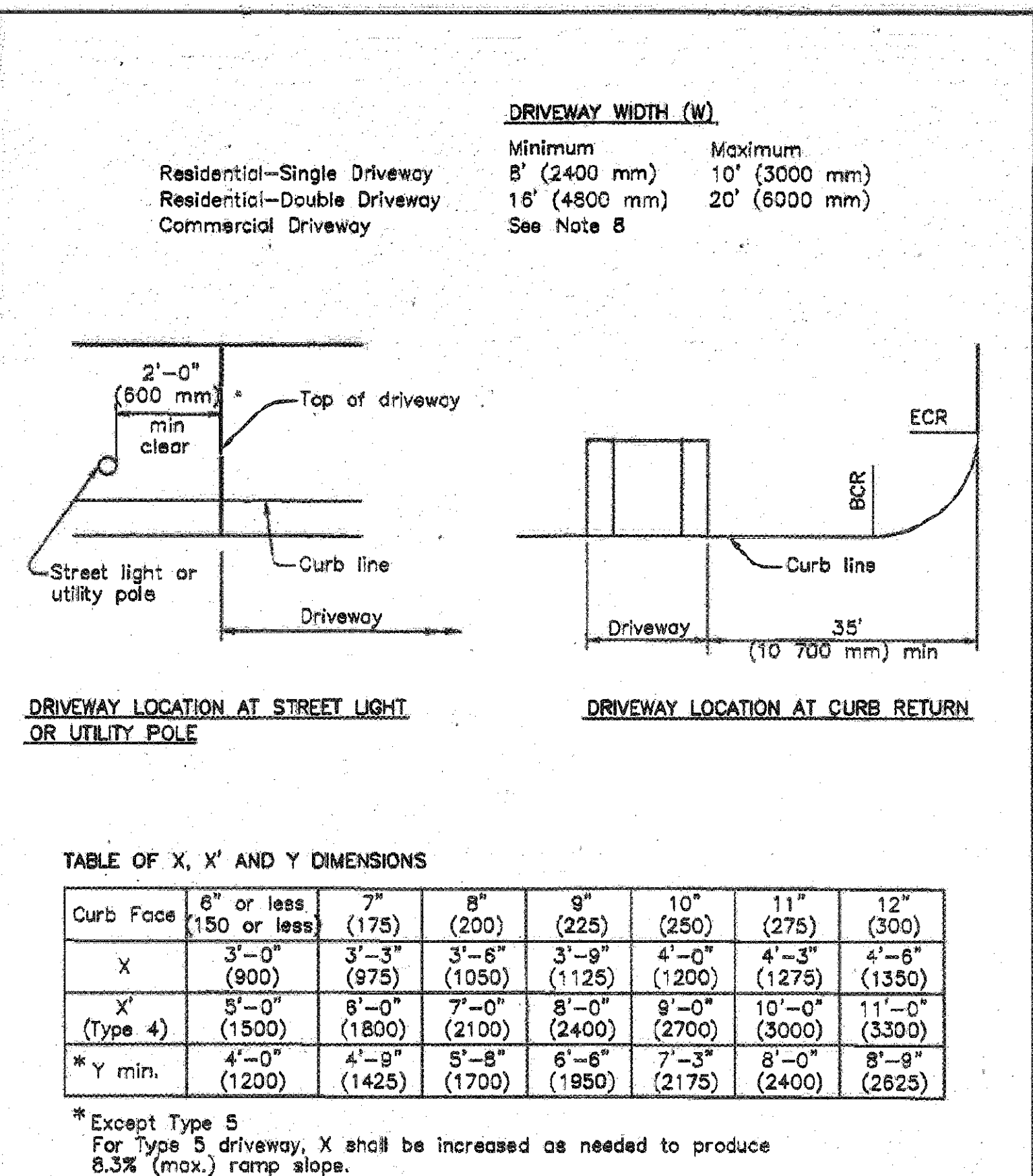

Dimensions are in millimeters, except as noted.

REVISIONS	CITY OF LONG BEACH, CALIFORNIA	STANDARD PLAN NO.
NO. DATE	DEPARTMENT OF PUBLIC WORKS	
06/10/98	DRIVEWAYS	105
07/10/02		
12/23/02	APPROVED BY: <i>Paul A. Duff</i> DATE: 4/13/10	SHEET
11/10/10	CITY ENGINEER R.E. No. 42988	2 OF 3

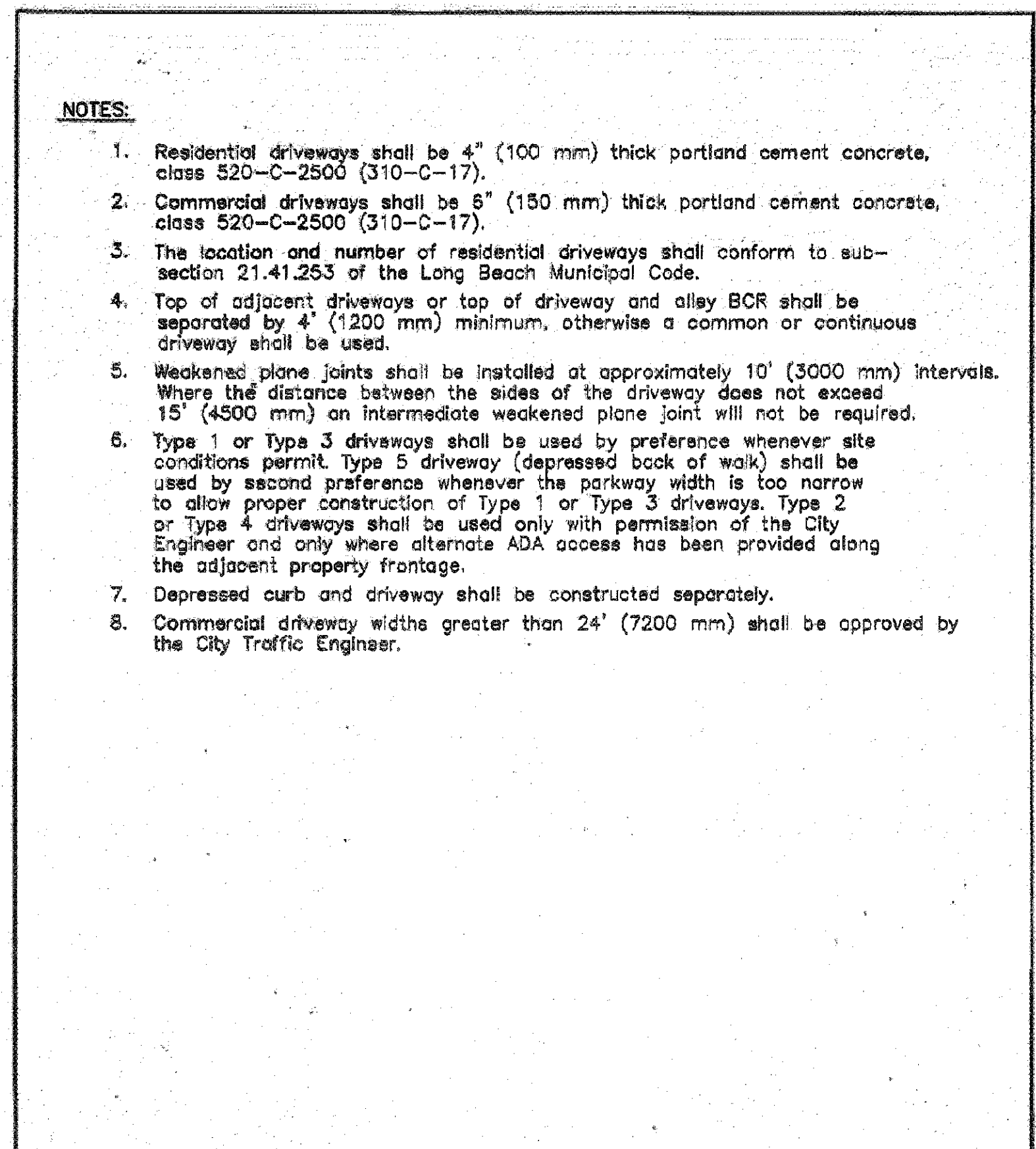

Dimensions are in millimeters, except as noted.

REVISIONS	CITY OF LONG BEACH, CALIFORNIA	STANDARD PLAN NO.
NO. DATE	DEPARTMENT OF PUBLIC WORKS	
07/10/02	DRIVEWAYS	105
12/23/02		
02/27/03	APPROVED BY: <i>Paul A. Duff</i> DATE: 4/13/10	SHEET
11/10/10	CITY ENGINEER R.E. No. 42988	3 OF 3

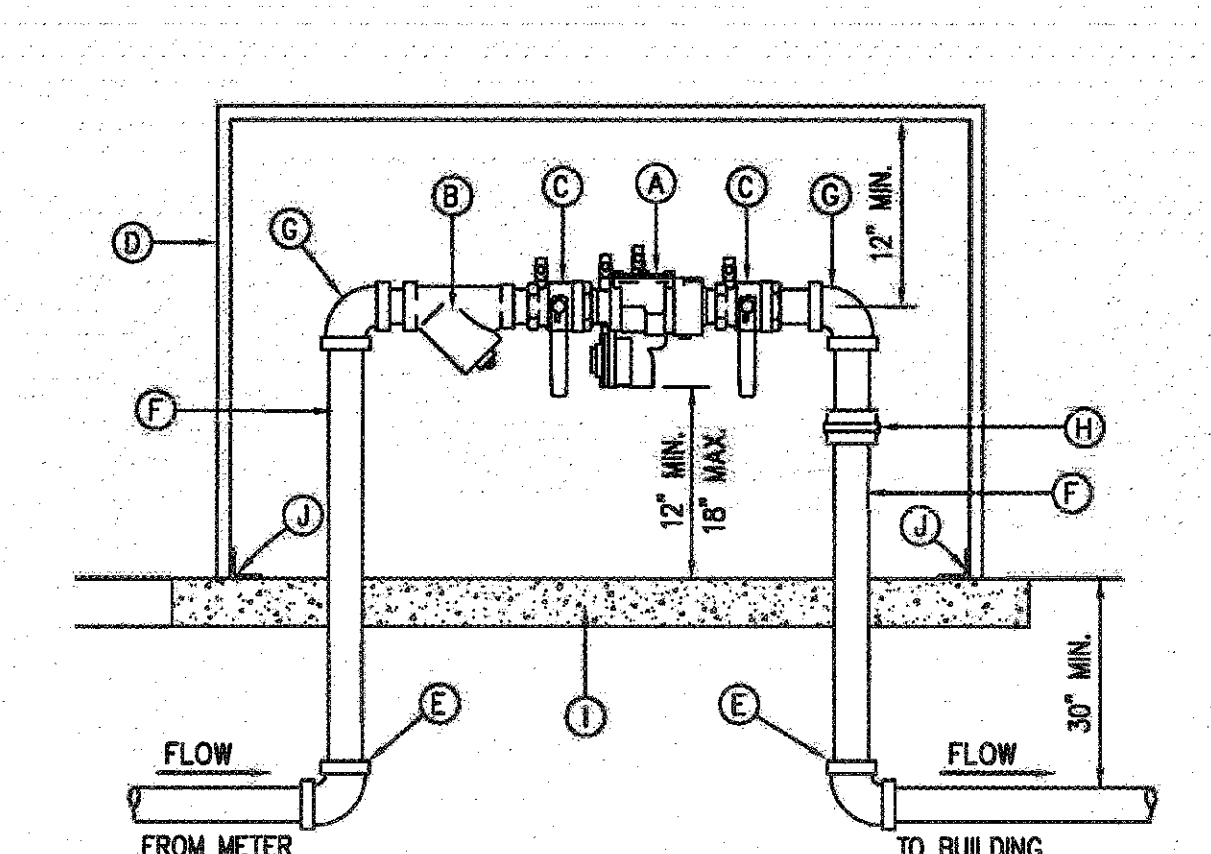

2" BACKFLOW PREVENTER DETAIL

- NOTES:
- ALL ABOVE GROUND MATERIAL TO BE PAINTED WITH ONE COAT DUNN EDWARDS VERSAPRIME 42-44 AND TWO COATS DUNN EDWARDS SYNTHETIC DARK BLUE.
 - CONTRACTOR SHALL BE RESPONSIBLE FOR THE INSTALLATION, INITIAL TEST AND CERTIFICATION OF ALL NEW OR RELOCATED BACKFLOW PREVENTION DEVICES. BACKFLOW DEVICE MUST BE TESTED BY A LOS ANGELES COUNTY CERTIFIED TESTER, PAID FOR BY THE CONTRACTOR, BEFORE WATER SERVICE IS ACTIVATED.
 - CONTRACTOR SHALL INSTALL A 2-INCH PRESSURE REGULATING VALVE ON THIS ASSEMBLY, IN FRONT OF THE STRAINER, WHERE STATIC WATER PRESSURE IN THE WATER SUPPLY PIPING IS EXCEEDING 80 POUNDS PER SQUARE INCH AS IS REQUIRED BY CALIFORNIA PLUMBING CODE SECTION 608.2.
 - ALL BELOW GROUND FERROUS PIPE AND FITTINGS SHALL BE DOUBLE POLYETHYLENE ENCASED IN SLEEVES, 10-MIL MINIMUM THICKNESS.

- BACKFLOW PREVENTER LIST OF MATERIALS
- (A) 2" LEAD FREE REDUCED PRESSURE PRINCIPLE ASSEMBLY APPROVED BY THE FOUNDATION FOR CROSS-CONNECTION CONTROL AND HYDRAULIC RESEARCH, INC.
 - (B) 2" STRAINER, CAST IRON BODY, THREADED
 - (C) 2" BRONZE BALL VALVE
 - (D) GREEN EXPANDED METAL VANDAL RESISTANT BACKFLOW COVER COATED WITH POLYMER ALLOY COATING AND PADLOCK
 - (E) COUPLING/ELBOW
 - (F) RISER & NIPPLES - TYPE "K" COPPER
 - (G) 90° ELBOW - COPPER
 - (H) BRASS UNION
 - (I) 4" THICK CONCRETE SLAB, MIN. CLASS 520-C-2500. EXACT LOCATION TO BE VERIFIED IN THE FIELD.
 - (J) 1/2" HILTI KB TX S.S. WITH 2" MIN EMBEDMENT (ESR-1917).

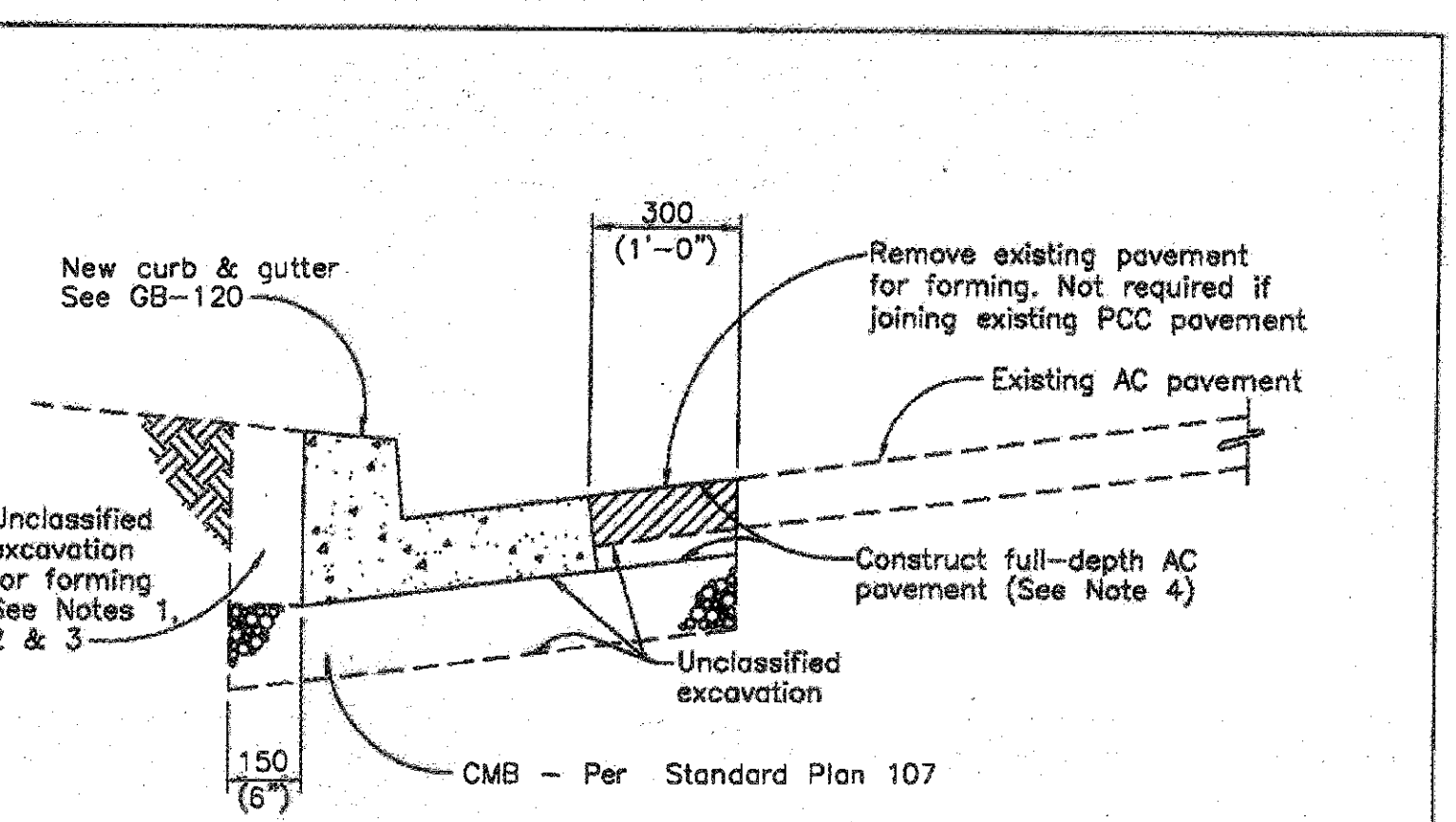

DETAIL AT CURB & GUTTER

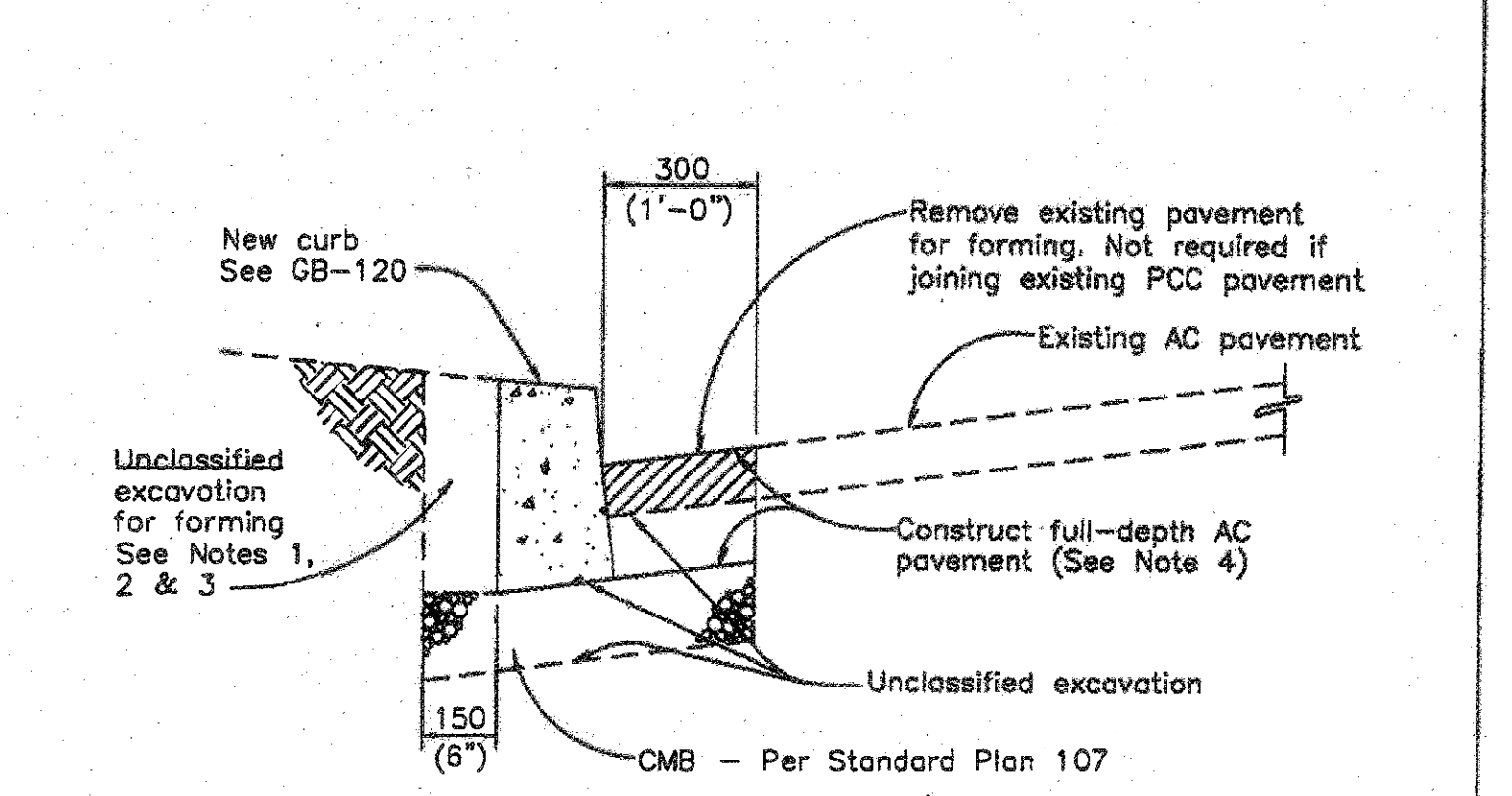

DETAIL AT CURB

REVISIONS	CITY OF LONG BEACH, CALIFORNIA	STANDARD PLAN NO.
NO. DATE	DEPARTMENT OF PUBLIC WORKS	
11/28/01	CURB & GUTTER, CURB AND SIDEWALK OR DRIVEWAY REPLACEMENT OR CONSTRUCTION	METRIC 116
12/23/02		
03/02/06	APPROVED BY: <i>Paul A. Duff</i> DATE: 4/13/10	SHEET
11/10/10	CITY ENGINEER R.E. No. 42988	1 OF 2

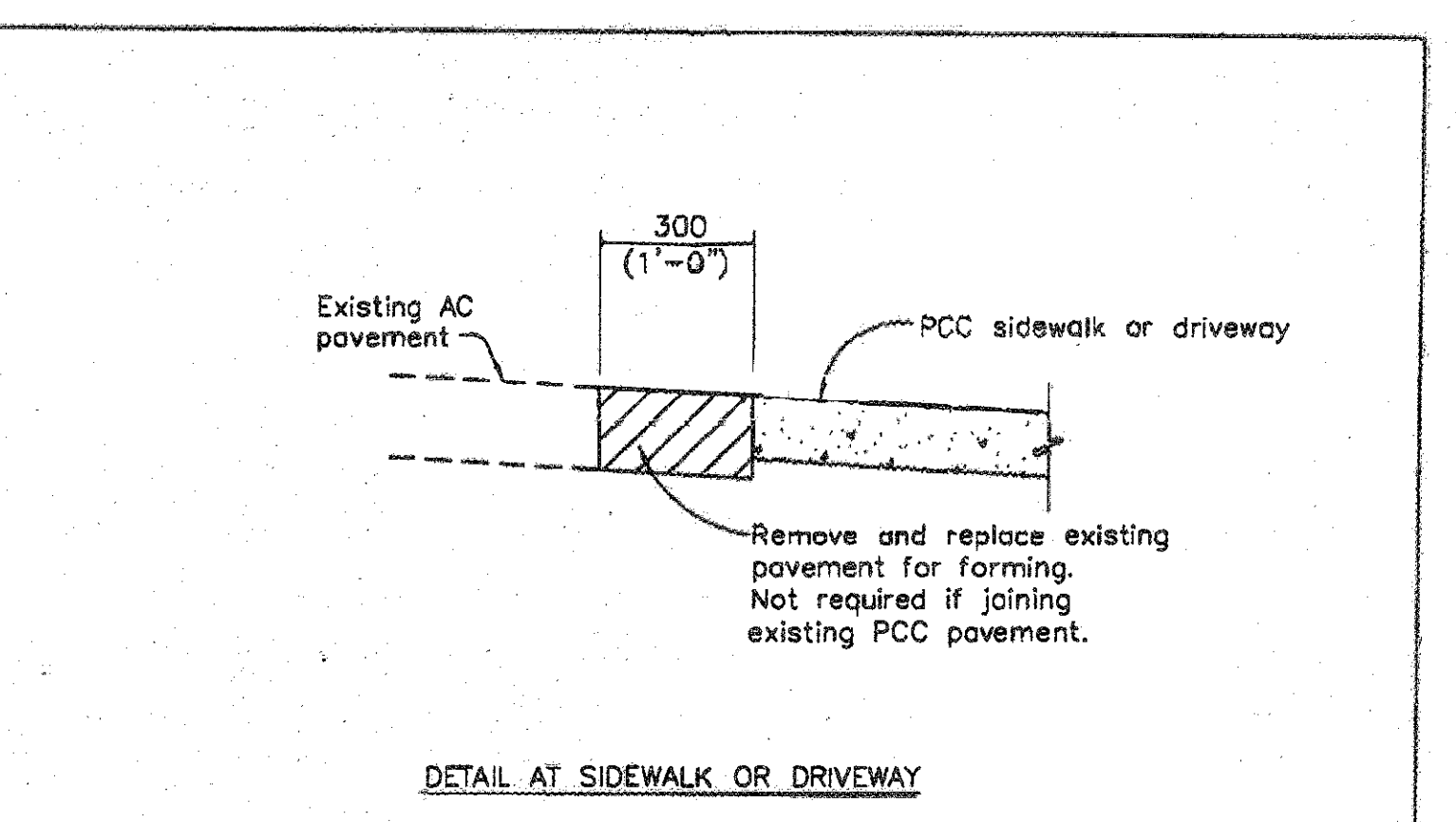

DETAIL AT SIDEWALK OR DRIVEWAY

- NOTES:
- Protect existing sprinkler systems, electrical conduit, water meters, service laterals, and all other underground utilities adjacent to curb and gutter replacement.
 - Backfill excavated area with clean earth from excavation.
 - Reseed to match existing lawn in excavated areas.
 - 50 mm (2") asphalt concrete pavement on Class 60-E-1 (200-E-200) slurry may be used in lieu of full-depth asphalt concrete pavement restoration.

REVISIONS	CITY OF LONG BEACH, CALIFORNIA	STANDARD PLAN NO.
NO. DATE	DEPARTMENT OF PUBLIC WORKS	
06/15/98	CURB & GUTTER, CURB AND SIDEWALK OR DRIVEWAY REPLACEMENT OR CONSTRUCTION	METRIC 116
12/23/02		
03/02/06	APPROVED BY: <i>Paul A. Duff</i> DATE: 4/13/10	SHEET
11/10/10	CITY ENGINEER R.E. No. 42988	2 OF 2

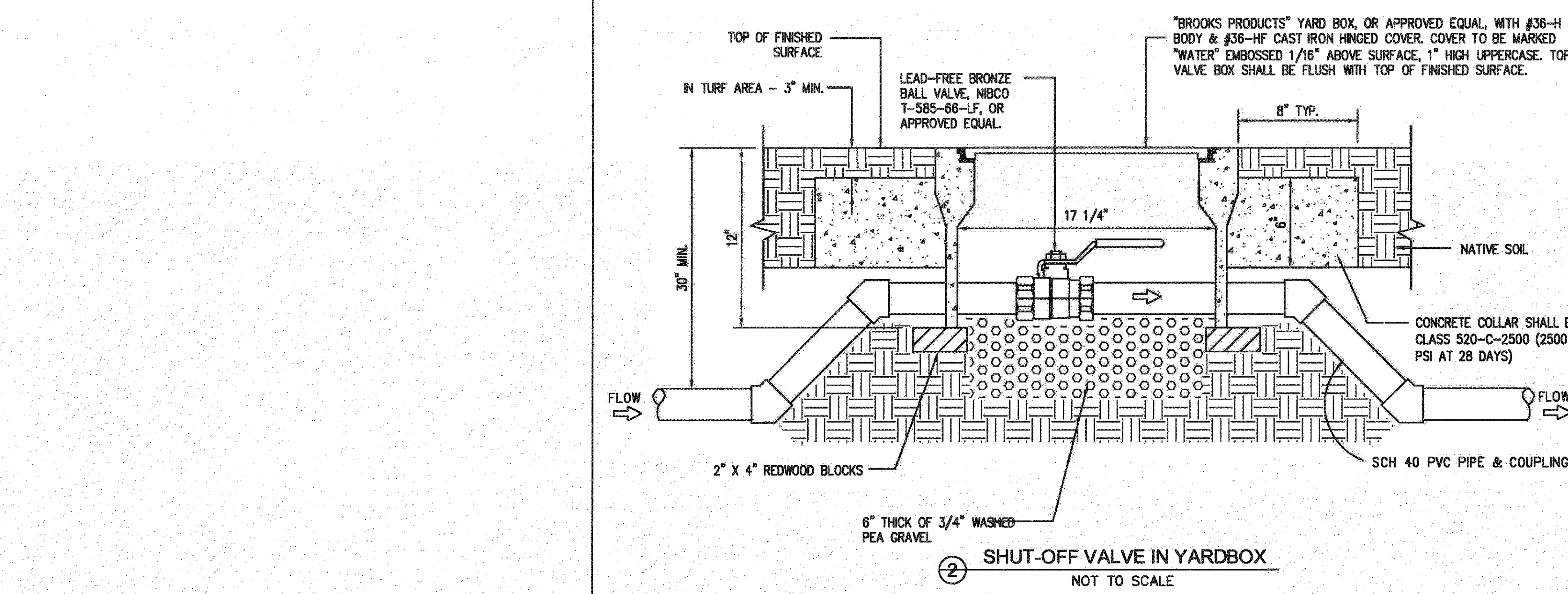
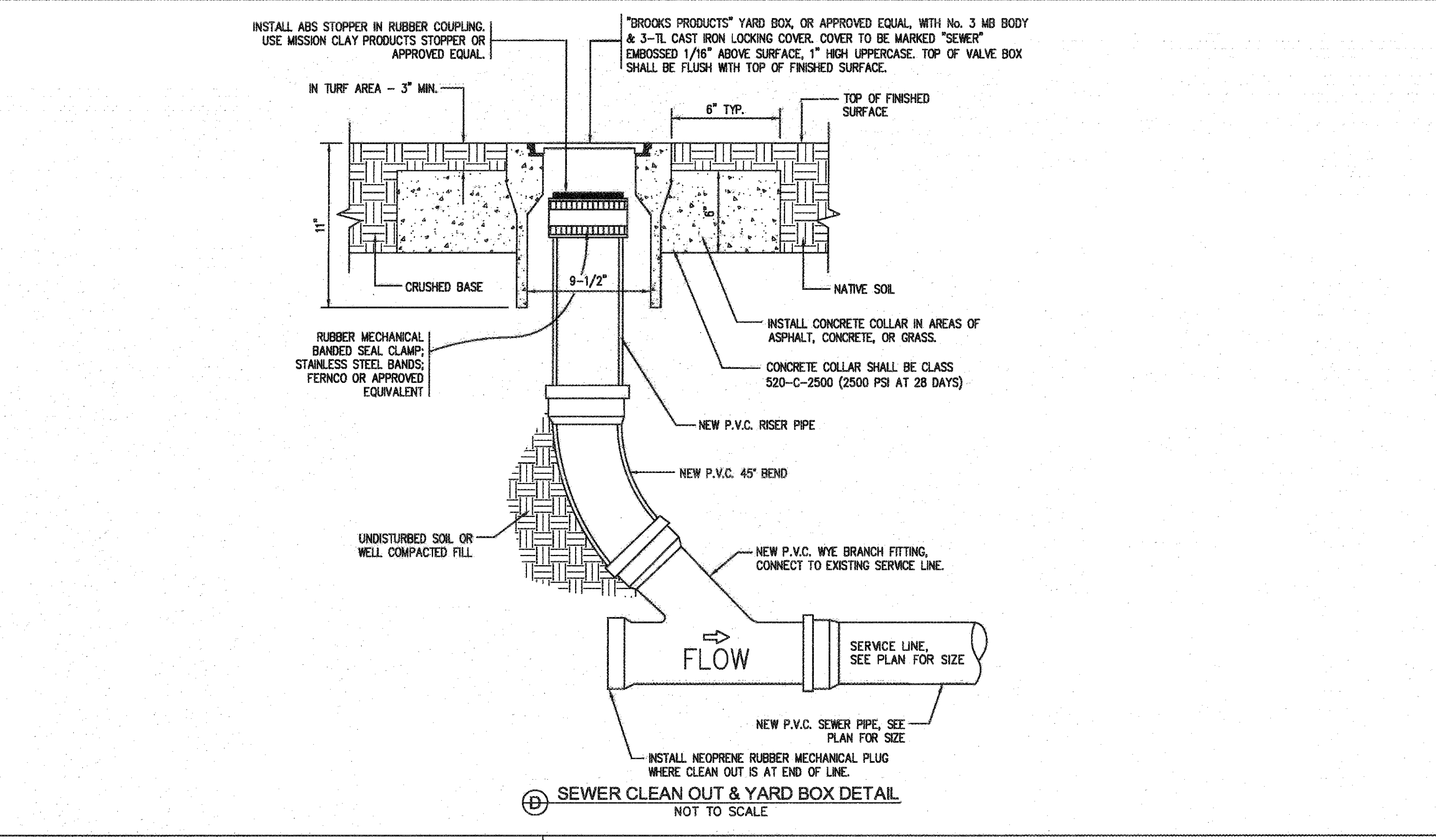

SHUT-OFF VALVE IN YARDBOX NOT TO SCALE

LITTLE
DIVERSIFIED ARCHITECTURAL CONSULTING

1300 Dove Street, Suite 100
Newport Beach, CA 92660
T: 949.698.1400 F: 949.698.1433
www.littleonline.com

This drawing and the design shown are the property of Little Diversified Architectural Consulting. The reproduction, copying or other use of this drawing without their written consent is prohibited and any engagement will be subject to their terms.

© Little 2016

**COMPTON
CCD**

PROJECT NAME

CAMPUS PUBLIC SAFETY BUILDING

1111 EAST ARTESIA BOULEVARD,
COMPTON CALIFORNIA 90221

IDENTIFICATION STAMP
DIV. OF THE STATE ARCHITECT
OFFICE OF REGULATION SERVICES

FILE NO: 19-C1
AR: 03-117673

AC: RLS
DATE: DEC 12 2017

FPL FPL and Associates, Inc.
Traffic Transportation-Civil-CAD
30 Corporate Park, Suite 401
Irvine, CA 92606
Phone: 949-252-1088

DESIGNED BY: RC
PRINCIPAL IN CHARGE: RC
PROJECT MANAGER: RC
DRAWN BY: AL

NO. REASON DATE

GRADING DETAIL SHEET

913-4675-00

12/10/16 C1.3

IRRIGATION NOTES:

- ALL WORK SHALL CONFORM TO APPLICABLE CODES.
- T.C.L.A., INC. HAS PREPARED THESE PLANS FROM BASE INFORMATION PROVIDED BY LITTLE DIVERSIFIED ARCHITECTS, NEWPORT BEACH, CALIFORNIA. CONTRACTOR SHALL FAMILIARIZE HIMSELF WITH THESE PLANS FOR ALL PERTINENT INFORMATION RELATING TO SITE CONSTRUCTION.
- THIS DESIGN IS DIAGRAMMATIC. ALL PIPING, VALVES, AND OTHER EQUIPMENT SHOWN WITHIN PAVED AREAS OR OUT OF PROPERTY BOUNDARIES ARE FOR DESIGN CLARIFICATION ONLY AND SHALL BE INSTALLED IN PLANTING AREAS WHERE POSSIBLE. NEVER INSTALL IRRIGATION OUTSIDE OF PROPERTY LINES OR LIMITS INDICATED ON PLAN. CONTRACTOR SHALL VERIFY LOCATIONS OF ALL ABOVE-GRADE IRRIGATION EQUIPMENT WITH THE DISTRICT PRIOR TO INSTALLATION, OR CONTRACTOR MAY BE REQUIRED TO MOVE THIS EQUIPMENT AT THE CONTRACTOR'S OWN COST.
- DO NOT WILLFULLY INSTALL THE IRRIGATION SYSTEM AS SHOWN ON THE DRAWINGS WHEN IT IS OBVIOUS IN THE FIELD THAT OBSTRUCTIONS, GRADE DIFFERENCES, OR DIFFERENCES IN THE AREA DIMENSIONS EXIST THAT MIGHT NOT HAVE EXISTED AT THE TIME OF THE IRRIGATION DESIGN PREPARATION. SUCH OBSTRUCTIONS OR DIFFERENCES SHOULD BE BROUGHT TO THE ATTENTION OF THE OWNER'S AUTHORIZED REPRESENTATIVE IMMEDIATELY. IN THE EVENT THIS NOTIFICATION IS NOT GIVEN, THE IRRIGATION CONTRACTOR SHALL ASSUME FULL RESPONSIBILITY FOR ANY REVISIONS NECESSARY TO BRING THE SYSTEM TO A PROPER WORKING CONDITION TO THE OWNER'S SATISFACTION.
- THE IRRIGATION CONTRACTOR SHALL BE RESPONSIBLE FOR INSTALLING ALL CONTROL WIRING, CONTROL WIRE SLEEVES, LATERAL AND MAINLINE PIPING, AND PIPE SLEEVING UNDER ALL PAVED AREAS PER PLAN PRIOR TO PAVING. ALL SLEEVING SHALL BE PVC SCHEDULE 40 PIPE AND BE A MINIMUM TWICE THE ENCLOSED PIPE SIZE AND 1-1/2" MINIMUM DIAMETER.
- 120 V.A.C. ELECTRICAL POWER SHALL BE PROVIDED TO THE CONTROLLER LOCATION BY OTHERS. IT SHALL BE THE RESPONSIBILITY OF THE IRRIGATION CONTRACTOR TO MAKE THE FINAL HOOK-UP FROM THE ELECTRICAL SOURCE TO THE CONTROLLER UNIT ONLY.
- THE IRRIGATION SYSTEM DESIGN IS BASED ON THE MINIMUM OPERATING PRESSURE AND THE MAXIMUM FLOW DEMAND SHOWN ON THE DRAWINGS AT THE POINT OF CONNECTION. THE IRRIGATION CONTRACTOR SHALL VERIFY WATER PRESSURE PRIOR TO CONSTRUCTION. REPORT ANY DIFFERENCES BETWEEN THE WATER PRESSURE INDICATED ON THE DRAWINGS AND THE ACTUAL PRESSURE READING THE IRRIGATION POINT OF CONNECTION TO THE DISTRICT. IN THE EVENT PRESSURE DIFFERENCES ARE NOT REPORTED PRIOR TO THE START OF THE IRRIGATION SYSTEM CONSTRUCTION, THE IRRIGATION CONTRACTOR SHALL ACQUIRE FULL RESPONSIBILITY FOR ANY REVISIONS NECESSARY TO BRING THE SYSTEM TO A PROPER WORKING CONDITION.
- THE HYDRAULIC CALCULATIONS FOR THIS IRRIGATION SYSTEM HAVE BEEN ESTABLISHED USING THE MATERIALS AS SPECIFIED ON THIS PLAN. SUBSTITUTIONS MADE TO THE MATERIALS BY THE CONTRACTOR WITHOUT PREVIOUS ACCEPTANCE BY THE LANDSCAPE ARCHITECT SHALL PLACE ALL LIABILITY OF THE IRRIGATION SYSTEM ONTO THE IRRIGATION CONTRACTOR. NO SUBSTITUTIONS OF EQUIPMENT WILL BE ACCEPTABLE WITHOUT PRIOR WRITTEN APPROVAL BY THE LANDSCAPE ARCHITECT. THE IRRIGATION CONTRACTOR SHALL BE REQUIRED TO REMOVE AND REPLACE ALL SUBSTITUTED EQUIPMENT WITH SPECIFIED EQUIPMENT IF SO ORDERED BY THE DISTRICT.
- INSTALL ALL MATERIALS AND EQUIPMENT AS SHOWN IN THE DETAILS. USE TEFLON TAPE ON ALL PVC MALE PIPE THREADS ON ALL SPRINKLER SWING JOINT AND VALVE ASSEMBLIES.
- CONTRACTOR SHALL PROVIDE AND INSTALL IN-LINE SWING CHECK VALVES AND ADJUSTABLE IN-RISER CHECK VALVES IF CONDITIONS EXIST WHICH REQUIRE CHECK VALVES TO AVOID BACK DRAINAGE TO LOWER EMITTERS AT NO ADDITIONAL COST TO THE OWNER.
- REFER TO SPECIFICATIONS FOR SUBMITTALS, INSPECTIONS AND OTHER APPLICABLE INFORMATION.
- THE EMITTERS SELECTED REPRESENT THE BEST ESTIMATE FOR WATER FLOWS BASED ON THE PLANT TYPE, SIZE, WATER USE AND MICROCLIMATE. FIELD ADJUSTMENTS MAY BE REQUIRED DEPENDING ON PLANT PERFORMANCE. CONTRACTOR SHALL ADJUST VALVE TIMING PROGRAM START TIMES AND EMITTER FLOWS AS REQUIRED FOR BEST GROWTH RESULTS.

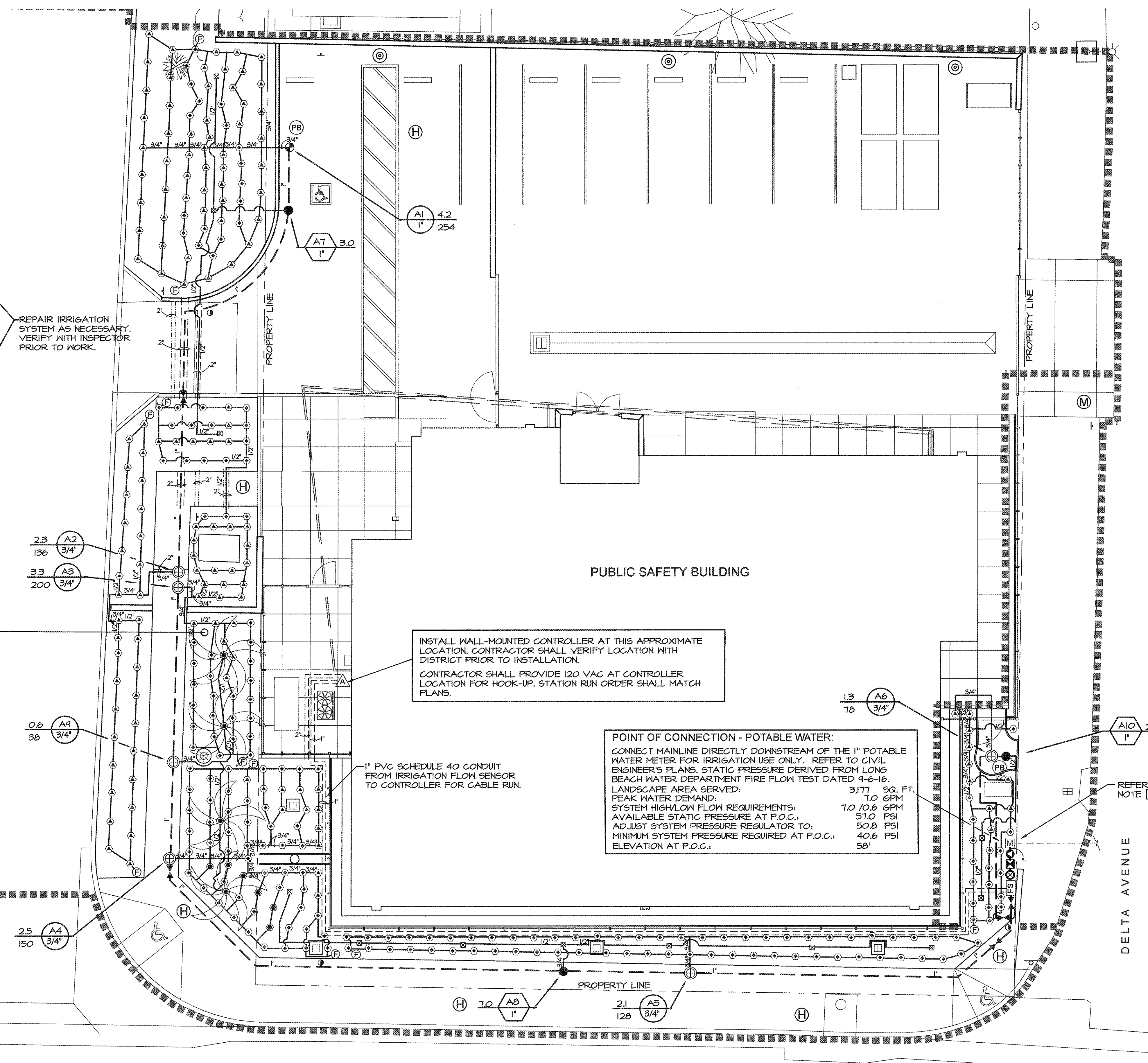

PUBLIC SAFETY BUILDING

2.3 A2 156 3/4"
3.3 A3 200 3/4"

0.6 A4 38 3/4"

2.5 A4 150 3/4"

INSTALL WALL-MOUNTED CONTROLLER AT THIS APPROXIMATE LOCATION. CONTRACTOR SHALL VERIFY LOCATION WITH DISTRICT PRIOR TO INSTALLATION. CONTRACTOR SHALL PROVIDE 120 VAC AT CONTROLLER LOCATION FOR HOOK-UP. STATION RUN ORDER SHALL MATCH PLANS.

POINT OF CONNECTION - POTABLE WATER:
CONNECT MAINLINE DIRECTLY DOWNSTREAM OF THE 1" POTABLE WATER METER FOR IRRIGATION USE ONLY. REFER TO CIVIL ENGINEER'S PLANS. STATIC PRESSURE DERIVED FROM LONG BEACH WATER DEPARTMENT FIRE FLOW TEST DATED 4-6-16.
LANDSCAPE AREA SERVED: 3,171 SQ. FT.
PEAK WATER DEMAND: 1.0 GPM
SYSTEM HIGH/LOW FLOW REQUIREMENTS: 1.0 / 0.6 GPM
AVAILABLE STATIC PRESSURE AT P.O.C.: 57.0 PSI
ADJUST SYSTEM PRESSURE REGULATOR TO: 50.8 PSI
MINIMUM SYSTEM PRESSURE REQUIRED AT P.O.C.: 40.6 PSI
ELEVATION AT P.O.C.: 58'

REFER TO CIVIL PLANS FOR METER, NOTE []

DRIP IRRIGATION LEGEND:

SYMBOL	PRODUCT	MODEL	DESCRIPTION	DETAIL
⊕	RAINBIRD	XGZ-075-PRF	LOW-FLOW CONTROL ZONE KIT. KIT INCLUDES 3/4" VALVE, AND 80 PSI IN-LINE PRESSURE REGULATOR. FLOW RATES FROM 0.2 GPM TO 5 GPM.	13 / L-4
⊕	RAINBIRD	XGZ-100-PRF	MEDIUM-FLOW CONTROL ZONE KIT. KIT INCLUDES 1" VALVE, AND 40 PSI IN-LINE PRESSURE REGULATOR. FLOW RATES FROM 3 GPM TO 15 GPM.	13 / L-4
⊕	NETAFIM	TL50V	PVC 1/2" MANUAL FLUSH VALVE FOR SYSTEM FLUSH VALVE WITH 48" FLUSH HOSE	2 / L-5
⊕	RAINBIRD	TREE ASSEMBLY	EXISTING PALM IRRIGATION DETAIL USING RAINBIRD XF SERIES DRIPLINE, SEE DETAIL	1 / L-5
⊕	RAINBIRD	SHRUB EMITTER	TWO (2)-INDIVIDUAL OUTLETS PER SHRUB, WITH 2-GPH RAINBIRD XERI-BUG DRIP EMITTER USE WITH RAINBIRD XBF2EL 1/4" BARB TRANSFER FITTINGS	14/15 / L-4
⊕	RAINBIRD	SHRUB EMITTER	TWO (2)-INDIVIDUAL OUTLETS PER SHRUB, WITH 1-GPH RAINBIRD XERI-BUG DRIP EMITTER USE WITH RAINBIRD XBF2EL 1/4" BARB TRANSFER FITTINGS	14/15 / L-4
⊕	RAINBIRD	SHRUB EMITTER	TWO (2)-INDIVIDUAL OUTLETS PER SHRUB, WITH 0.5-GPH RAINBIRD XERI-BUG DRIP EMITTER USE WITH RAINBIRD XBF2EL 1/4" BARB TRANSFER FITTINGS	14/15 / L-4

EMITTER LEGEND

EMITTER	PLANT MATERIAL	WUCOLS	CONTAINER SIZE	BASEIN DIAM.	BASEIN AREA	EMITTER/COLOR	EMITTER GPH	NUMBER PER PLANT	TOTAL GPH PER PLANT
⊕	EXISTING PALMS		EXISTING	6'	30 SF	—	—	SEE DETAIL	9.5
⊕	SHRUBS:								
⊕	AGAVE ATTENUATA	L	5 GALLON	2'	3 SF	XB-05PC-1032/BLUE	0.5	2	1.0
⊕	CARISSA MACROCARPA	M	5 GALLON	2'	3 SF	XB-20PC-1032/RED	2.0	2	4.0
⊕	DIANELLA TASMANICA	M	5 GALLON	2'	3 SF	XB-20PC-1032/RED	2.0	2	4.0
⊕	ILEX VOMITORIA 'STOKES'	L	5 GALLON	2'	3 SF	XB-10PC-1032/BLACK	1.0	2	2.0
⊕	LANTANA 'NEB GOLD'	L	5 GALLON	2'	3 SF	XB-10PC-1032/BLACK	1.0	2	2.0
⊕	LIGUSTRUM JAPONICUM	M	5 GALLON	2'	3 SF	XB-20PC-1032/RED	2.0	2	4.0
⊕	MIMLENERBIA CAPILLARIS	M	5 GALLON	2'	3 SF	XB-20PC-1032/RED	2.0	2	4.0
⊕	MYOPORUM PARVIFOLIUM	L	5 GALLON	2'	3 SF	XB-10PC-1032/BLACK	1.0	2	2.0
⊕	SALVIA CHAMAEDRYOIDES	L	5 GALLON	2'	3 SF	XB-10PC-1032/BLACK	1.0	2	2.0
⊕	SALVIA GREGGII 'RED'	L	5 GALLON	2'	3 SF	XB-10PC-1032/BLACK	1.0	2	2.0

DRIP SYSTEMS:

- ⊕ DENOTES CONTROLLER (LETTER) AND VALVE (NUMBER) SEQUENCE
- ⊕ 21.4" DENOTES MAXIMUM GALLONS PER MINUTE (GPM) FLOW THROUGH VALVE
- ⊕ 128" DENOTES MAXIMUM GALLONS PER HOUR (GPH) FLOW THROUGH VALVE
- ⊕ DENOTES VALVE SIZE

HYDROZONE LEGEND:

- H DENOTES AREA WITHIN HIGH WATER USE ZONES, THESE ARE SOUTH AND WEST EXPOSURES WITH FULL SUN.
- M DENOTES AREA WITHIN MODERATE WATER USE ZONES, THESE ARE NORTH AND EAST EXPOSURES WITH MODERATE SHADE.
- HYDROZONE BOUNDARY

SYMBOL	PRODUCT	MODEL	DESCRIPTION	DETAIL
⊕	HUNTER	I-CORE	POTABLE IRRIGATION WATER METER. SEE CIVIL ENGINEER'S PLANS. AUTOMATIC 12 STATION IRRIGATION CONTROLLER 'A' FACTORY ASSEMBLED CONTROLLER WITHIN A "STRONGBOX" WALL-MOUNTED, VANDAL-RESISTANT STAINLESS STEEL ENCLOSURE. INFERIAL SUPPLY SPECIFICATION NUMBER: ICA16-HUT-12/SP/SOLS/NHF-100C/HFL, GREEN PRODUCT SALES, DARYL GREEN, (444) 584-7311. MOUNT AT HEIGHT FOR EASY OPERATION. OPTIONS INCLUDE: ICA16-HJ-12: 12 STATION HUNTER I-CORE CONTROLLER IN WALL-MOUNTED SS ENCLOSURE SP: SURGE PROTECTION HF-100C: 1" FLOW SENSOR HFL: HIGH FLOW SHUT-OFF LIGHT ON ENCLOSURE SOLS/N: WIRELESS SOLAR-SYNCH WEATHER STATION	3 / L-4
⊕	CARSON	910-12B	10" ROUND PLASTIC CONTROL AND COMMON WIRE FULL BOX. COIL MINIMUM 24" OF WIRE WITHIN BOX. FULL DIFFERENT COLOR WIRE FROM CONTROLLER TO EACH PULL BOX AT THE END OF MAINLINES.	3 / L-4
⊕	ZURN-WILKINS	500XL	PRESSURE REDUCING VALVE - LINE SIZE ON BACKFLOW RISER.	4 / L-4
⊕	FEBCO	825Y	RP BACKFLOW PREVENTER - 1". INSTALL WITHIN A "STRONGBOX" LOW PROFILE SMOOTH TOUCH STAINLESS STEEL METAL WIRE MESH ENCLOSURE 586C-30554R	6 / L-5
⊕	HAMMOND	820I	BRONZE FULL PORT BALL VALVE - LINE SIZE TO 3"	9 / L-4
⊕	RAINBIRD	FESB	NORMALLY-CLOSED MASTER VALVE - 1". PROVIDE WITH RAINBIRD SOL-ADA SOLENOID ADAPTER.	7 / L-4
⊕	RAINBIRD	PEB	ELECTRIC REMOTE CONTROL VALVE IN BOX - SIZE PER PLAN	3 / L-5
⊕	GST	IFS-100C	FLOW SENSOR - 1". INSTALL DEVICE AND CABLE PER MANUFACTURER'S SPECIFICATIONS	8 / L-4
⊕	RAINBIRD	33DLRC	QUICK COUPLING VALVE WITH YELLOW RUBBER LOCKING CAP - 3/4"	10 / L-4
⊕	RAINBIRD	1402	TWO (2) - 0.5 GPM BUBBLERS PER TREE LOCATION, PLACE OPPOSITE SIDES OF ROOT BALL, WITHIN TREE BASIN	4 / L-4
---			BURIED SCHEDULE 40 PVC PRESSURE MAINLINE PIPING, SIZE PER PLAN.	516 / L-4
---			BURIED SCHEDULE 40 PVC PRESSURE MAINLINE PIPING. MAIN FEED LINES FROM VALVE ARE SIZED, ALL OTHER EMITTER PIPING SHALL BE 1/2" UNLESS OTHERWISE DENOTED.	516 / L-4
---			PIPE SLEEVE, PVC SCH. 40, FOR IRRIGATION PIPING INSTALLED UNDER PAVING, SIZE NOTED ON PLAN. IF NO SIZE NOTED, USE TWICE THE DIAMETER OF THE INTERIOR PIPE. IRRIGATION CONTRACTOR SHALL INSTALL SLEEVING, INCLUDING WALL PENETRATIONS WHERE NECESSARY.	6 / L-4
---			CONTROL WIRE SLEEVE, PVC SCH. 40, INSTALLED UNDER PAVING BY IRRIGATION CONTRACTOR. SEE "SLEEVE LEGEND" FOR MINIMUM SIZES OF SLEEVES.	6 / L-4

SCALE: 1/8"=1'-0"

TCLA, Inc.
LANDSCAPE ARCHITECTURE - ENVIRONMENTAL DESIGN
CORPORATE OFFICE: JOSEBA WAKONINS, 205 S. LA. 6411737
27905 SMYTH DRIVE, VALENCIA, CALIFORNIA 91355
(PH) 661-702-1011 (FX) 661-702-0295

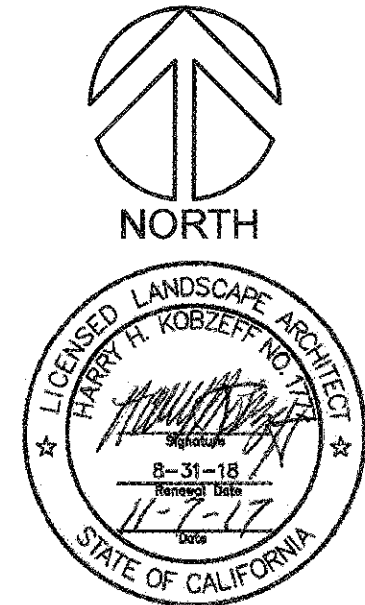

**COMPTON
CCD**

CAMPUS PUBLIC SAFETY BUILDING

**1111 EAST ARTESIA BOULEVARD,
COMPTON CALIFORNIA 90221**

MAWA: MAXIMUM APPLIED WATER ALLOWANCE: POINT OF CONNECTION: 1" IRR. METER

MAWA = (ETo x 0.45 x LA x 0.62) + (ETO x 1.0 x SLA x 0.62) = Gallons per year for LA + SLA.
 where:
 MAWA = Maximum Applied Water Allowance (gallons per year)
 ETO = Reference Evapotranspiration (Inches per year)
 ETAF = Evapotranspiration Adjustment Factor
 LA = Landscaped Area (square feet)
 SLA = Special Landscaped Area (square feet)
 0.45 = ETAF for Landscaped Area, 0.65 for schools
 1.0 = ETAF for Special Landscaped Area
 0.62 = Conversion factor (to gallons per square foot)

	ETo		ETAF		LA or SLA (square ft.)		Conversion		MAWA (Gallons per Year)
MAWA for LA	46.6	x	0.65	x	3,177	x	0.62	=	59,663
MAWA for SLA	46.6	x	1.0	x	0	x	0.62	=	0
Total MAWA =									59,663

EAWU: ESTIMATED APPLIED WATER USE POINT OF CONNECTION: 1" IRR. METER

EAWU = ETO x K_L x LA x 0.62 / IE = Gallons per year
 where:
 EAWU = Estimated Applied Water Use (gallons per year)
 ETO = Reference Evapotranspiration (Inches per year)
 K_L = Landscape Coefficient
 LA = Landscaped Area (square feet)
 0.62 = Conversion factor (to gallons per square foot)
 IE = Irrigation Efficiency

LANDSCAPE COEFFICIENT: K_L x K_d x K_m = K_L
 HOT = 0.3 x 0.8 x 1.2 = 0.3
 MODERATE = 0.3 x 0.8 x 0.8 = 0.2
 K_L = species factor - 0.1 (dry) - 0.4 (wet)
 K_d = density factor - 0.5 (sparse) - 1.3 (dense)
 K_m = microclimate factor - 0.5 (cool) - 1.4 (hot)

Hydrozone	ETo		K _L		LA or SLA (square ft.)		Conversion		IE	EAWU (Gallons per Year)
HOT	46.6	x	0.3	x	2,677	x	0.62	/	.81	= 28,646
MODERATE	46.6	x	0.2	x	196	x	0.62	/	.81	= 1,398
D.G.	46.6	x	0	x	304	x	0.62	/	.0	= 0
Total EAWU =										30,044

DRIP PRESSURE LOSS CHART
 VALVE: A1 ELEV. AT POC: 58.0
 GPM: 4.2 GPH: 286 STATIC PSI AT POC: 57.0

1" WATER METER	0.2 PSI
1" BACKFLOW PREVENTER	11.0 PSI
1" MASTER VALVE	1.7 PSI
1" FLOW SENSOR, (FIXED)	0.3 PSI
285 LF OF 1" MAINLINE (2.5 GPM)	2.1 PSI
FITTINGS (20% MAINLINE LOSS)	0.4 PSI
ELEVATION TO VALVE (+) UPHILL (58')	0.0 PSI
① TOTAL SYSTEM LOSSES TO VALVE INLET:	15.7 PSI
SUMMARY:	
② AVAILABLE STATIC PRESSURE AT POC:	57.0 PSI
③ DESIGN PRESSURE AT POC: ② x .75	42.8 PSI
④ TOTAL SYSTEM LOSSES TO VALVE INLET ①	15.7 PSI
⑤ RESIDUAL DYNAMIC PRESSURE @ VALVE: ③ - ④	27.1 PSI
DOWNSTREAM LATERAL LINE LOSSES:	
⑥ 3/4" DRIP VALVE (LPV)	3.8 PSI
⑦ 3/4" NYE FILTER (NON-REGULATING)	1.1 PSI
⑧ LATERAL LINE LOSSES, (FIXED)	5.0 PSI
⑨ CHECK VALVE LOSSES	0.0 PSI
⑩ EMITTER/DRIPLINE OPERATING PRESSURE	15.0 PSI
⑪ ELEVATION (+) UPHILL	0.0 PSI
⑫ TOTAL LATERAL SYSTEM LOSSES ⑥ THROUGH ⑪	24.9 PSI
⑬ RESIDUAL LATERAL SYSTEM PRESSURE: ⑤ - ⑫	2.2 PSI
⑭ TOTAL SYSTEM PRESSURE LOST: ① + ⑫	40.6 PSI
⑮ SET SYSTEM REGULATOR AT: ⑭ x 1.25	50.8 PSI

CONVENTIONAL PRESSURE LOSS CHART
 VALVE: A8 POC ELEV: 58.0
 GPM: 7.0 STATIC PSI AT POC: 57.0

1" WATER METER	0.4 PSI
1" BACKFLOW PREVENTER	11.0 PSI
1" MASTER VALVE	1.8 PSI
1" FLOW SENSOR, (FIXED)	0.3 PSI
75 LF OF 1" MAINLINE	1.0 PSI
FITTINGS (20% MAINLINE LOSS)	0.2 PSI
1" REMOTE CONTROL VALVE	1.8 PSI
LATERAL LINE LOSSES, (FIXED)	5.0 PSI
ELEVATION (+) UPHILL, (-) DOWNHILL (58')	0.0 PSI
SPRINKLER OPERATING PRESSURE:	15.0 PSI
① TOTAL SYSTEM LOSSES:	36.5 PSI
SUMMARY:	
② AVAILABLE STATIC PRESSURE AT POC:	57.0 PSI
③ AVAILABLE DYNAMIC PRESSURE AT POC: ② x .75	42.8 PSI
④ REQ'D SYSTEM MINIMUM DYNAMIC PRESSURE: ①	36.5 PSI
⑤ RESIDUAL DYNAMIC PRESSURE: ③ - ④	6.3 PSI

IDENTIFICATION STAMP
 DIV. OF THE STATE ARCHITECT
 OFFICE OF REGULATION SERVICES
 FILE NO: 19-C1
 AN: 03-117873
 AC: FLS: SS:
 DATE: DEC 12 2017

PRINCIPAL IN CHARGE
 RITA S. CARTER
 PROJECT MANAGER
 SHOJI TAKESHIMA / DAVID PHAN
 DRAWN BY
 DAVID PHAN

NO. REASON DATE

LANDSCAPE NOTES & LEGENDS

913-4675-01

11/21/17 L-2

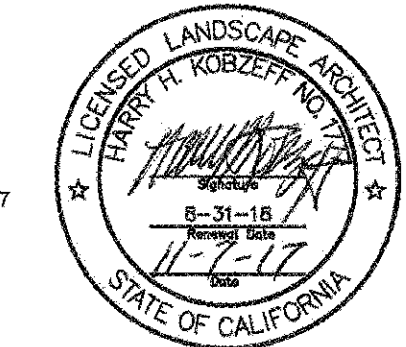
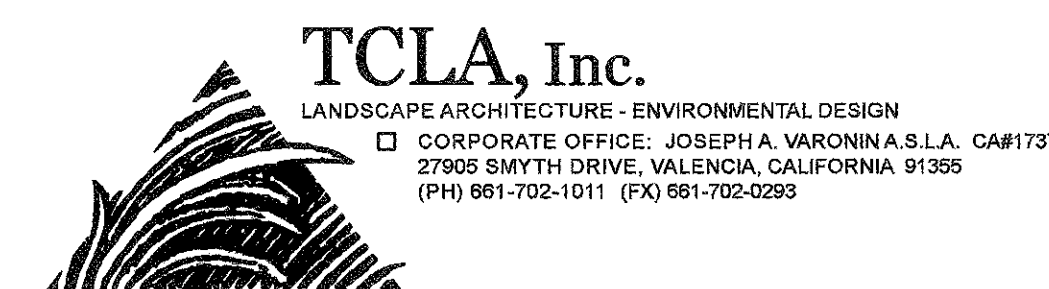

PLANTING NOTES:

- ALL WORK SHALL CONFORM TO APPLICABLE LOCAL CODES.
- ALL TREES SHALL BE STANDARD IN FORM, UNLESS OTHERWISE SPECIFIED.
- ALL PLANT LOCATIONS ARE DIAGRAMMATIC. ACTUAL LOCATIONS SHALL BE VERIFIED WITH THE DISTRICT PRIOR TO PLANTING.
- ALL PLANT MATERIAL WITHIN A SPECIES SHALL HAVE SIMILAR SIZE AND SHALL BE OF A FORM TYPICAL FOR THE SPECIES. ANY PLANT DEEMED UNACCEPTABLE BY THE DISTRICT SHALL BE IMMEDIATELY REMOVED FROM THE SITE AND SHALL BE REPLACED WITH AN ACCEPTABLE PLANT OF LIKE TYPE AND SIZE AT THE CONTRACTOR'S OWN EXPENSE. ANY MATERIAL APPEARING TO BE UNHEALTHY, EVEN IF DETERMINED TO STILL BE ALIVE, SHALL NOT BE ACCEPTED. THE DISTRICT SHALL BE THE SOLE JUDGE AS TO THE ACCEPTABILITY OF PLANT MATERIAL.
- IN DRIP IRRIGATED AREAS, A PRE-EMERGENT HERBICIDE SHALL BE APPLIED BETWEEN PLANT MATERIAL.
- FINISH GRADES SHALL BE INSTALLED 2" BELOW ALL CURBS, TOPS OF UTILITY BOXES, AND PAVING IN SHRUB AREAS.
- FINISH SURFACE SHALL BE A MINIMUM OF TWO (2) PERCENT AWAY FROM ALL BUILDINGS, AND MATCH CIVIL ENGINEERS FLOW LINES UNLESS OTHERWISE SHOWN.
- AFTER FINISH GRADES HAVE BEEN ESTABLISHED, CONTRACTOR SHALL HAVE SOIL SAMPLES TESTED BY AN ESTABLISHED SOIL TESTING LABORATORY FOR THE FOLLOWING: SOIL FERTILITY, ORGANIC MATTER CONTENT, AGRICULTURAL SUITABILITY, AND SALT AND BORON CONTENT. EACH SAMPLE SUBMITTED SHALL CONTAIN APPROXIMATELY ONE QUART OF SOIL, BUT NO LESS. CONTRACTOR SHALL ALSO SUBMIT THE PROJECT'S PLANT LIST TO THE LABORATORY ALONG WITH THE SOIL SAMPLES. THE SOIL REPORT PRODUCED BY THE LABORATORY SHALL CONTAIN RECOMMENDATIONS FOR THE FOLLOWING (AS APPROPRIATE):
ANALYTICAL RESULTS FOR THE SOILS:
SOIL pH
NUTRIENTS
SALINITY
TEXTURE
WATER INFILTRATION RATE
GENERAL RECOMMENDATIONS
PLANTING RECOMMENDATIONS:
BACKFILL MIXES FOR SHRUBS AND TREES
PRE-PLANT SOIL AMENDMENTS AND RATES FOR PLANTING AREAS
SOIL PREPARATION, RIPPING AND/OR ROTOTILLING SPECIFICATIONS
FERTILIZER PROGRAM:
ESTABLISHMENT PHASE FERTILIZERS AND RATES IN PLANTING BEDS.
ON-GOING MAINTENANCE PHASE FOR SAME.
- THE CONTRACTOR SHALL INSTALL SOIL AMENDMENTS AND FERTILIZERS PER THE SOILS REPORT RECOMMENDATIONS AFTER RECEIVING A CHANGE ORDER FROM THE DISTRICT. ANY CHANGE IN COST DUE TO THE SOIL REPORT RECOMMENDATIONS SHALL BE SUBMITTED TO THE DISTRICT WITH THE REPORT. FOR BIDDING PURPOSES ONLY, THE SOIL PREPARATION SHALL CONSIST OF THE FOLLOWING:
SHRUB AREAS:
INCORPORATE INTO THE TOP 6" OF SOIL BY MEANS OF ROTO-TILLING AFTER CROSS-RIPPING:
NITROGEN STABILIZED ORGANIC AMENDMENT - 4 CU. YDS. PER 1,000 S.F.
AMMONIUM PHOSPHATE 16-20-0 - 15 LBS PER 1,000 S.F.
AGRICULTURAL GYPSUM - 100 LBS PER 1,000 S.F.

PLANTING LEGEND:

T-LIE, JAP. — DENOTES QUANTITY IN GROUPING & PLANT MATERIAL, SEE LEGEND
15 GALLON — DENOTES MATERIAL SIZE IN GROUPING

HYDROZONE LEGEND:

(H) DENOTES AREA WITHIN HIGH WATER USE ZONES, THESE ARE SOUTH AND WEST EXPOSURES WITH FULL SUN
(M) DENOTES AREA WITHIN MODERATE WATER USE ZONES, THESE ARE NORTH AND EAST EXPOSURES WITH MODERATE SHADE.
■■■■■ HYDROZONE BOUNDARY

TREE LEGEND - SUNSET ZONE 22, WUCOLS ZONE 3 (SOUTH COASTAL)						
SYMBOL	BOTANICAL NAME	COMMON NAME	SIZE	QTY	REMARKS	WUCOLS
(A)	LOPHOSTEMON CONFERTUS STANDARD FORM	BRISBANE BOX	24" BOX	3	10'-12" HIGH X 4'-5" WIDE	M
(A)	RHAPHIOLEPIS INDICA MAJESTIC BEAUTY STANDARD FORM	INDIAN HAWTHORNE	24" BOX	4	8'-9" HIGH X 3'-4" WIDE	M

SHRUB AND GROUND COVER LEGEND - SUNSET ZONE 22, WUCOLS ZONE 3 (SOUTH COASTAL)						
ABBRV.	BOTANICAL NAME	COMMON NAME	SIZE	QTY	WUCOLS	
AGA ATT	AGAVE ATTENUATA	NGN	5 GALLON	6	L	
CAR MAC	CARISSA MACROCARPA 'GREEN CARPET'	PROSTRATE NATAL PLUM	5 GALLON	50	M	
DIA TAS	DIANELLA TASMANICA 'CASA BLUE'	CASA BLUE FLAX LILY	5 GALLON	33	M	
ILE VOM	ILEX VOMITORIA 'STOKES'	YALPON	5 GALLON	50	L	
LAN NG	LANTANA 'NEH GOLD'	NEH GOLD LANTANA	5 GALLON	21	L	
MUH CAP	MUHLENBERGIA CAPILLARIS 'REGAL MIST'	REGAL MIST MUHLY	5 GALLON	50	M	
MYO PAR	MYOPORUM PARVIFOLIUM 'PUTAH CREEK'	PROSTRATE MYOPORUM	5 GALLON	61	L	
SAL CHA	SALVIA CHAMAEDRYOIDES	GERMANDER SAGE	5 GALLON	7	L	
SAL GRE	SALVIA GREGGII 'RED'	AUTUMN SAGE	5 GALLON	41	L	
	DECOMPOSED GRANITE - CALIFORNIA GOLD COLOR		STABILIZED 1/4" MINUS	304 SQ. FT.	—	

NOTE: INSTALL PLANTS PER PLANTING DETAILS

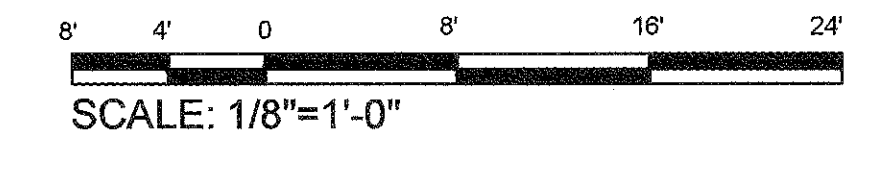

TCLA, Inc.
LANDSCAPE ARCHITECTURE - ENVIRONMENTAL DESIGN
CORPORATE OFFICE: JOSEFINA URONKINA S.L.A. CA#1737
27905 SMYTH DRIVE, VALENCIA, CALIFORNIA 91355
(PH) 861-702-1011 (FX) 861-702-9293

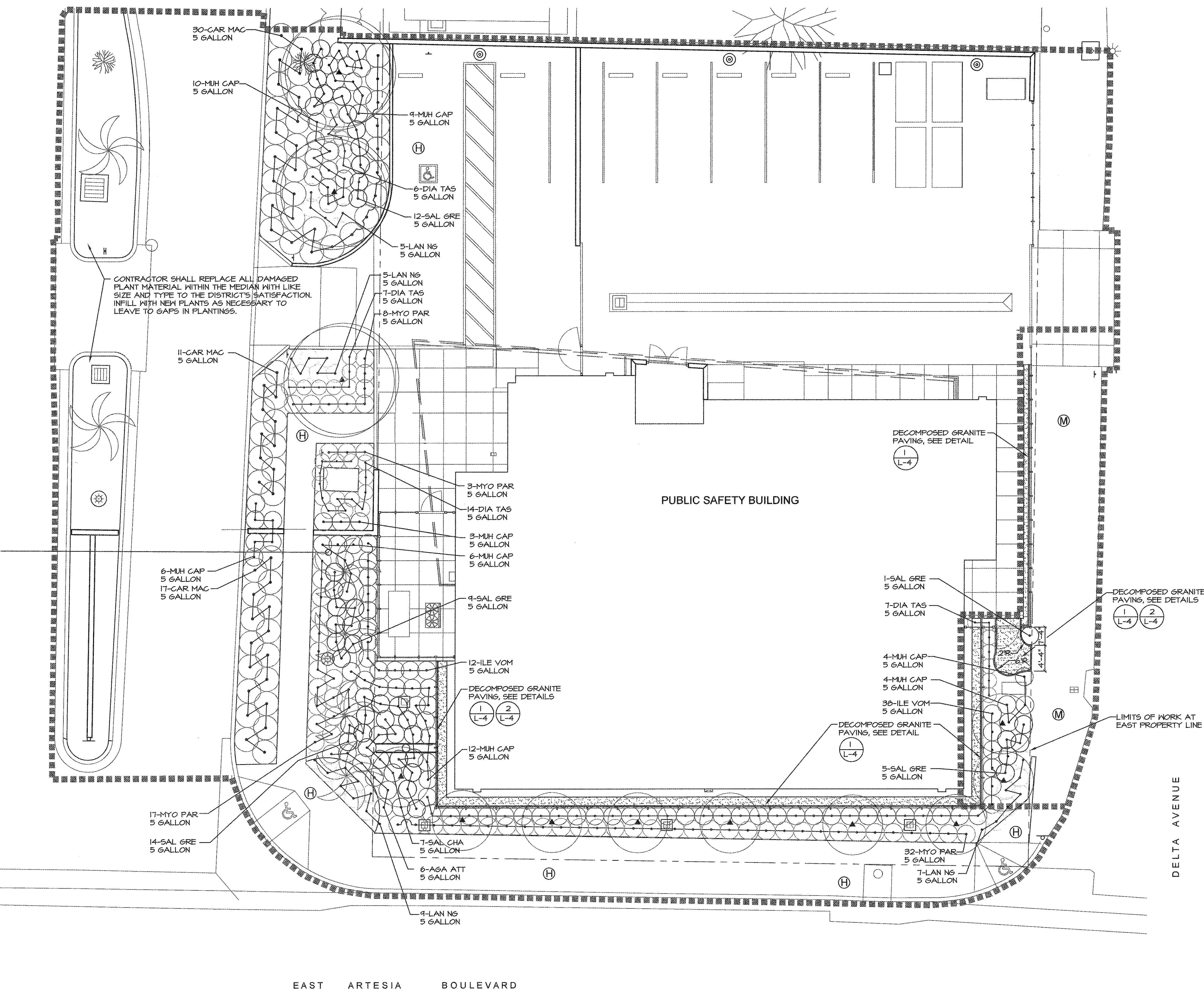
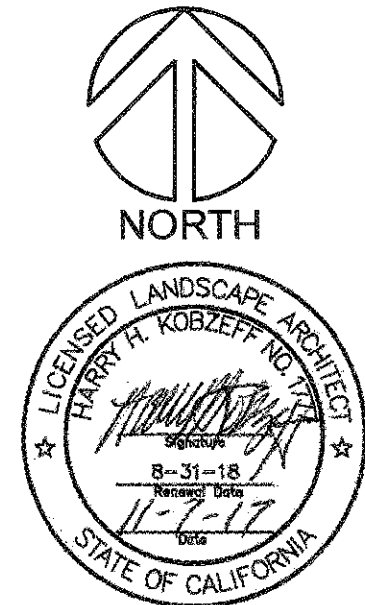

EAST ARTESIA BOULEVARD

PUBLIC SAFETY BUILDING

DELTA AVENUE

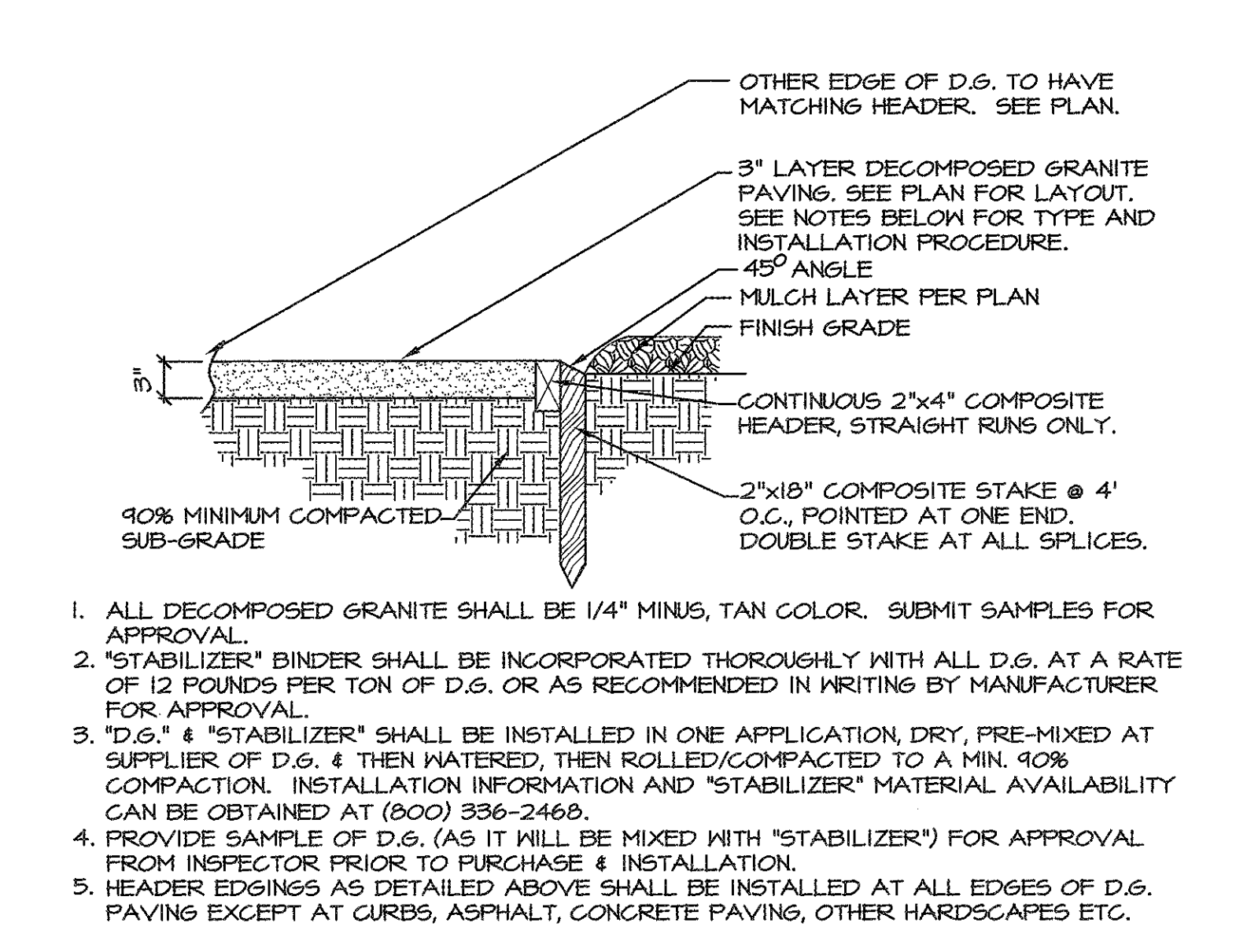

1 D.G. PAVING WITH STRAIGHT EDGE SCALE: 1"=1'-0"

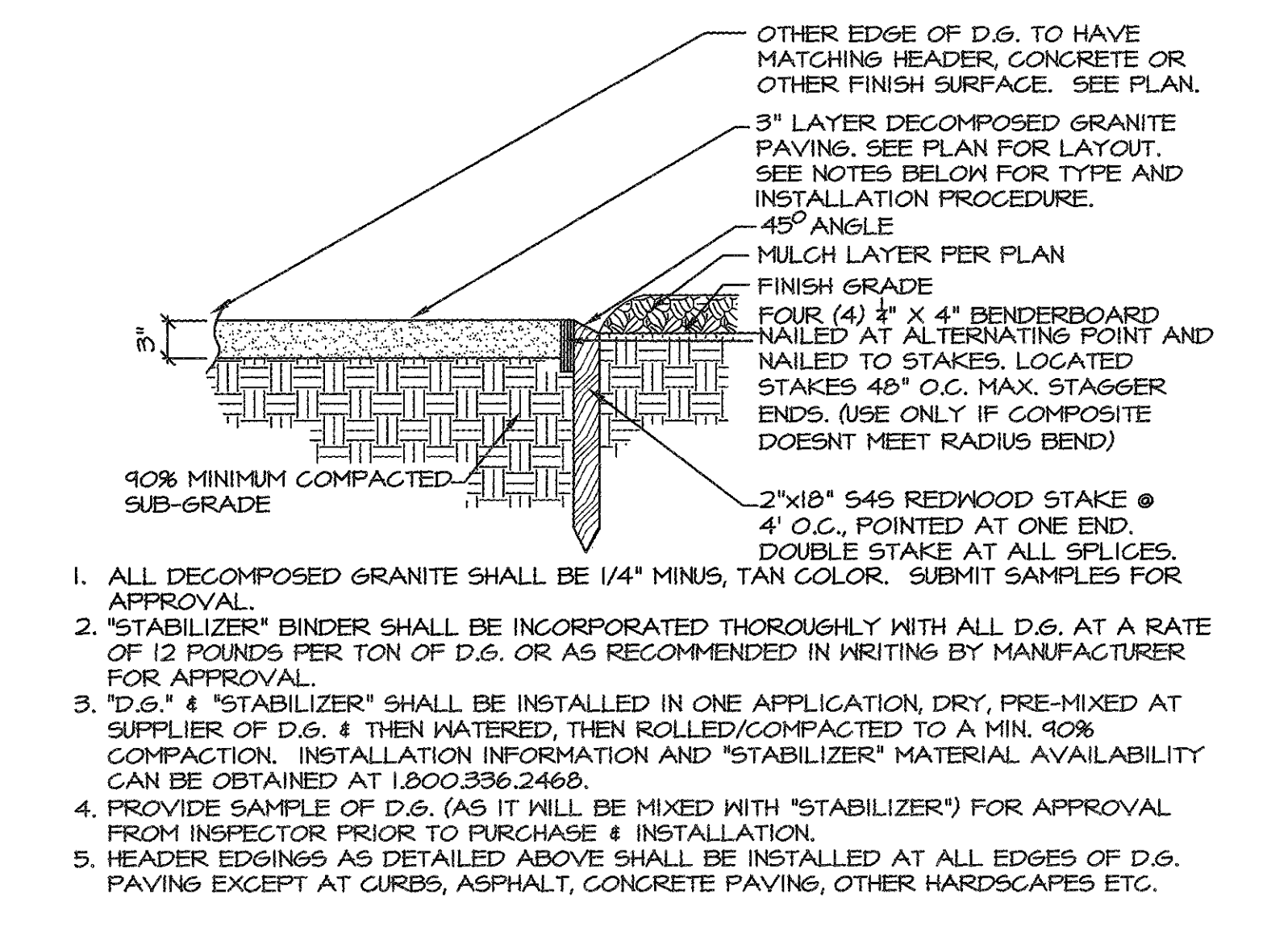

2 D.G. PAVING WITH CURVED EDGE SCALE: 1"=1'-0"

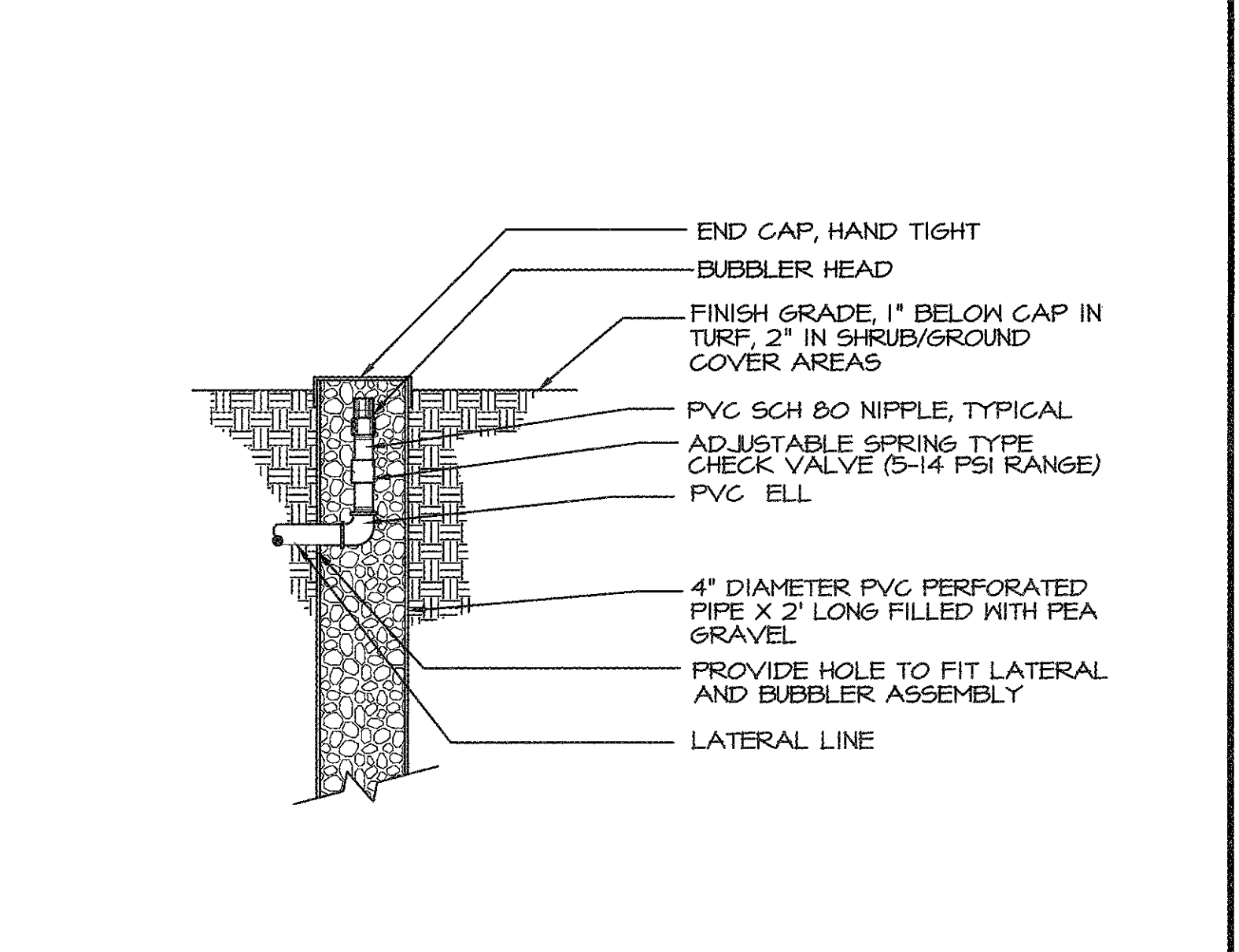

4 BUBBLER WITH DEEP WATERING PIPE SCALE: NTS

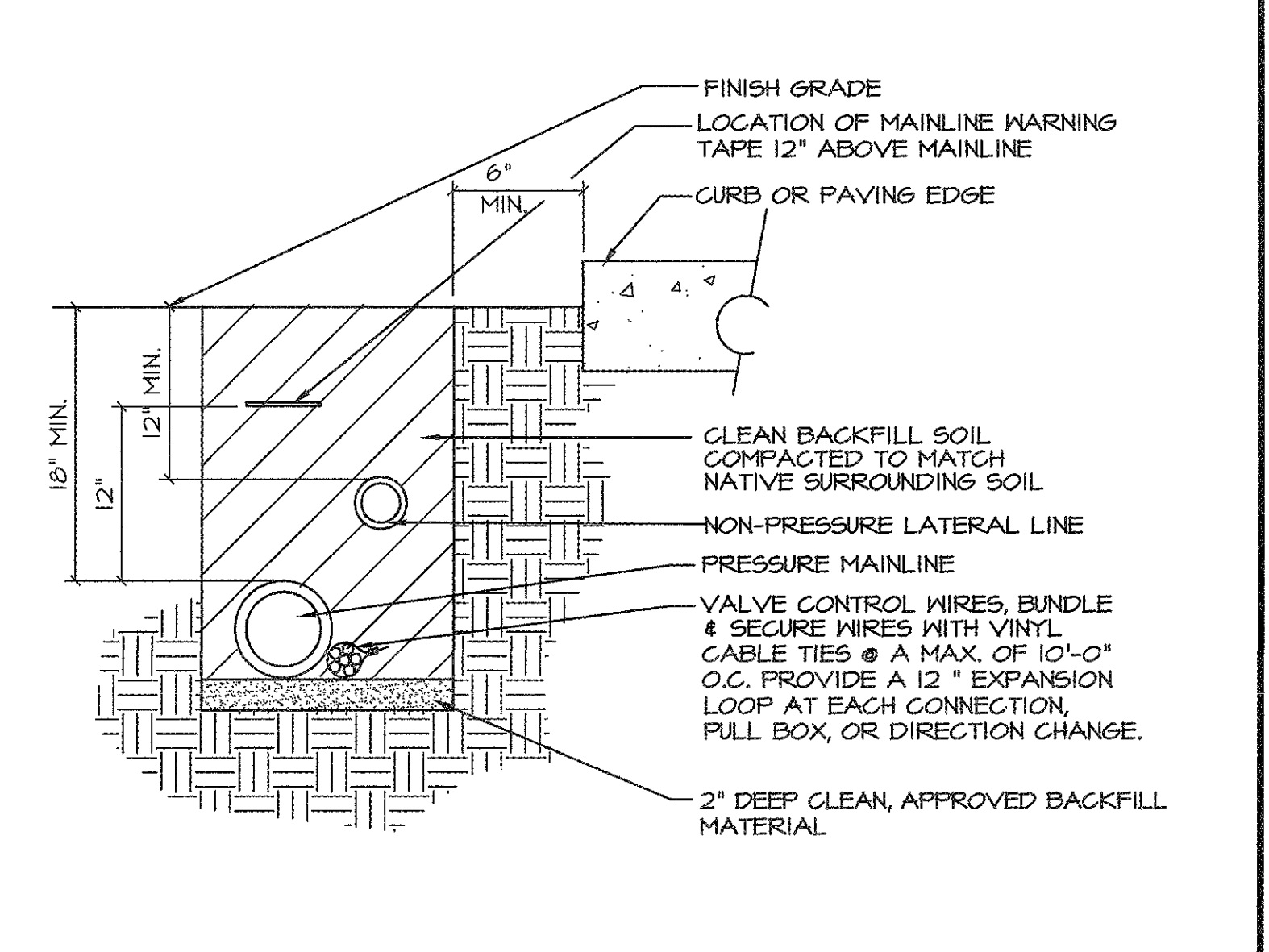

5 IRRIGATION TRENCHING DETAIL SCALE: NTS

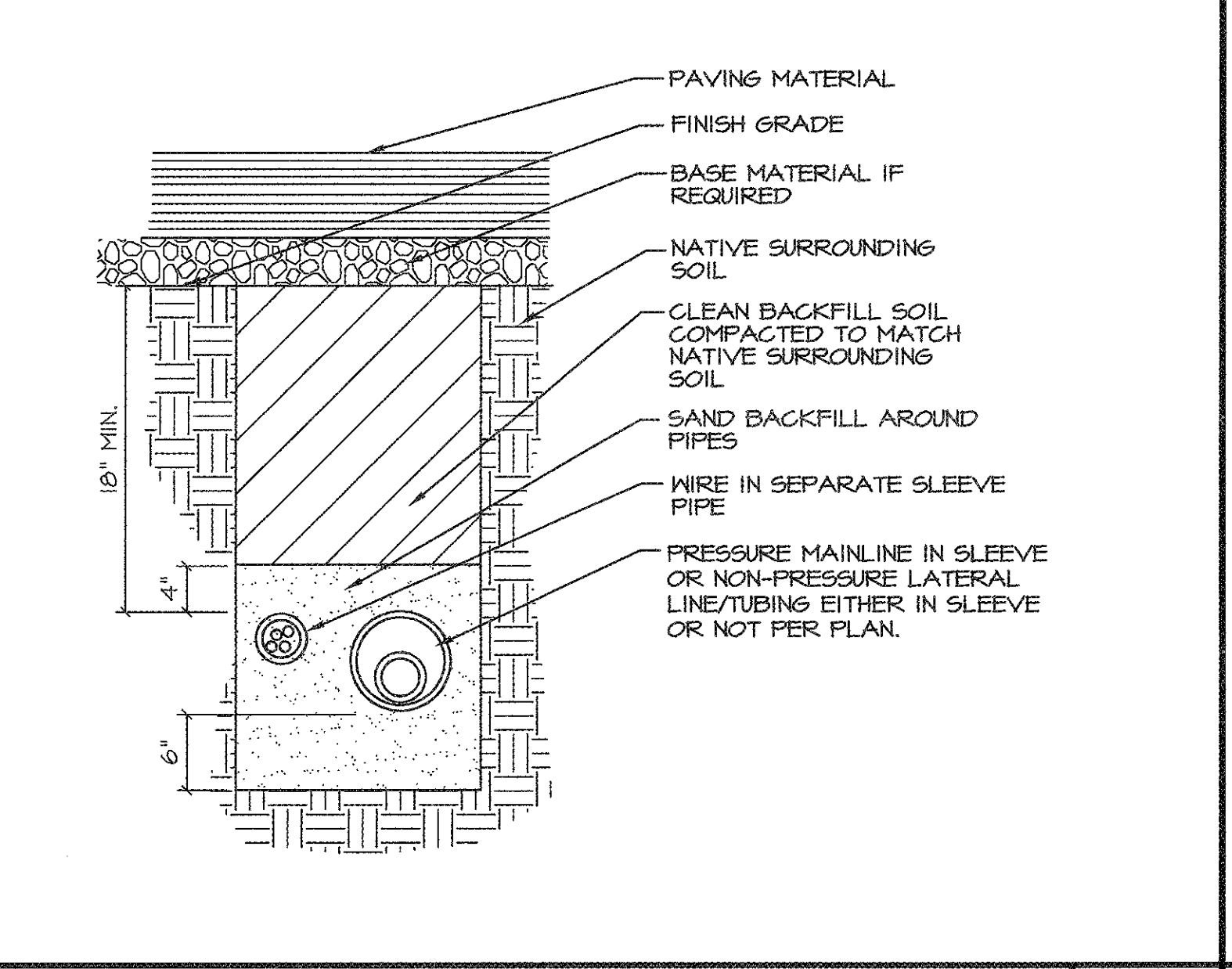

6 IRRIGATION SLEEVING DETAIL SCALE: NTS

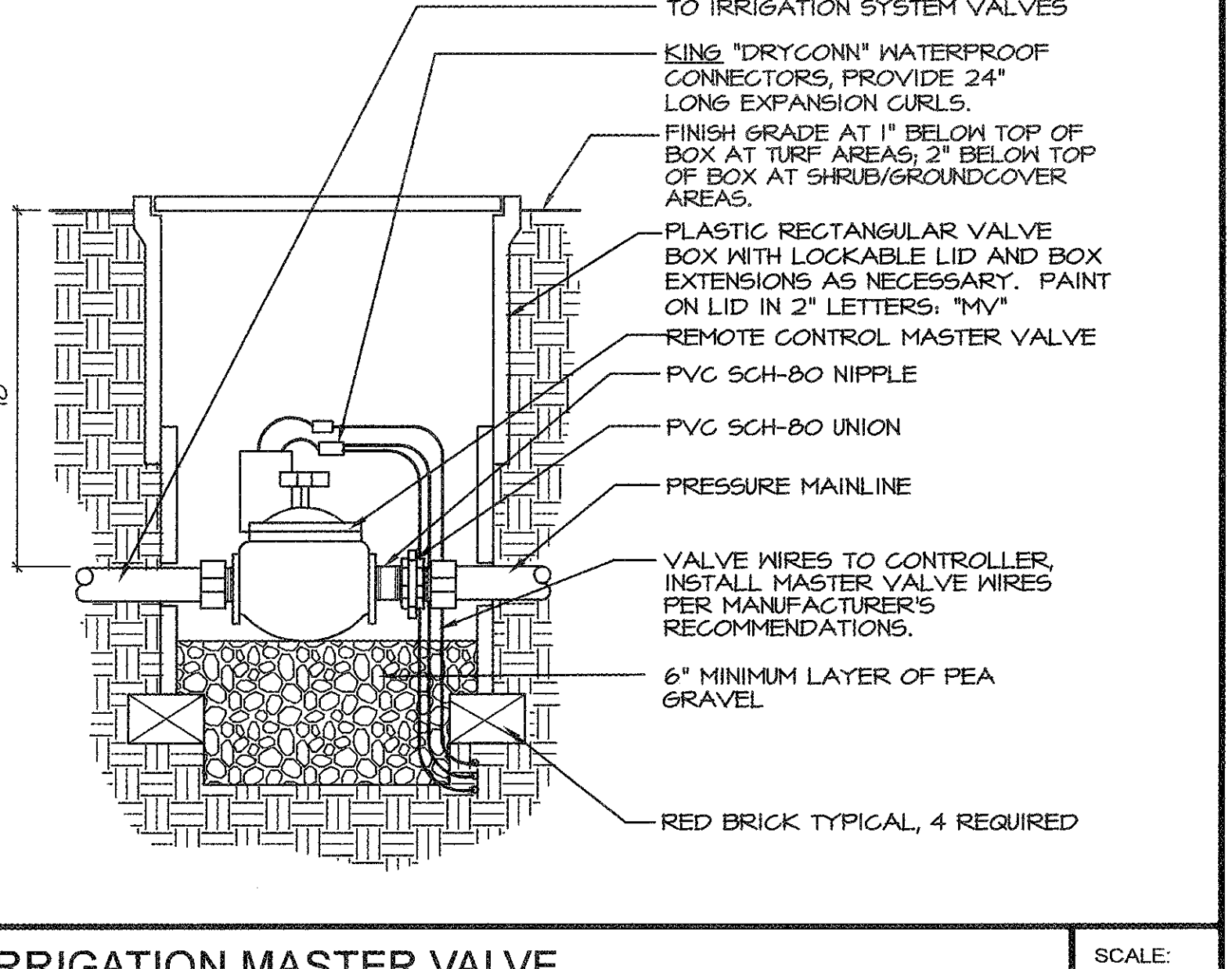

7 IRRIGATION MASTER VALVE SCALE: NTS

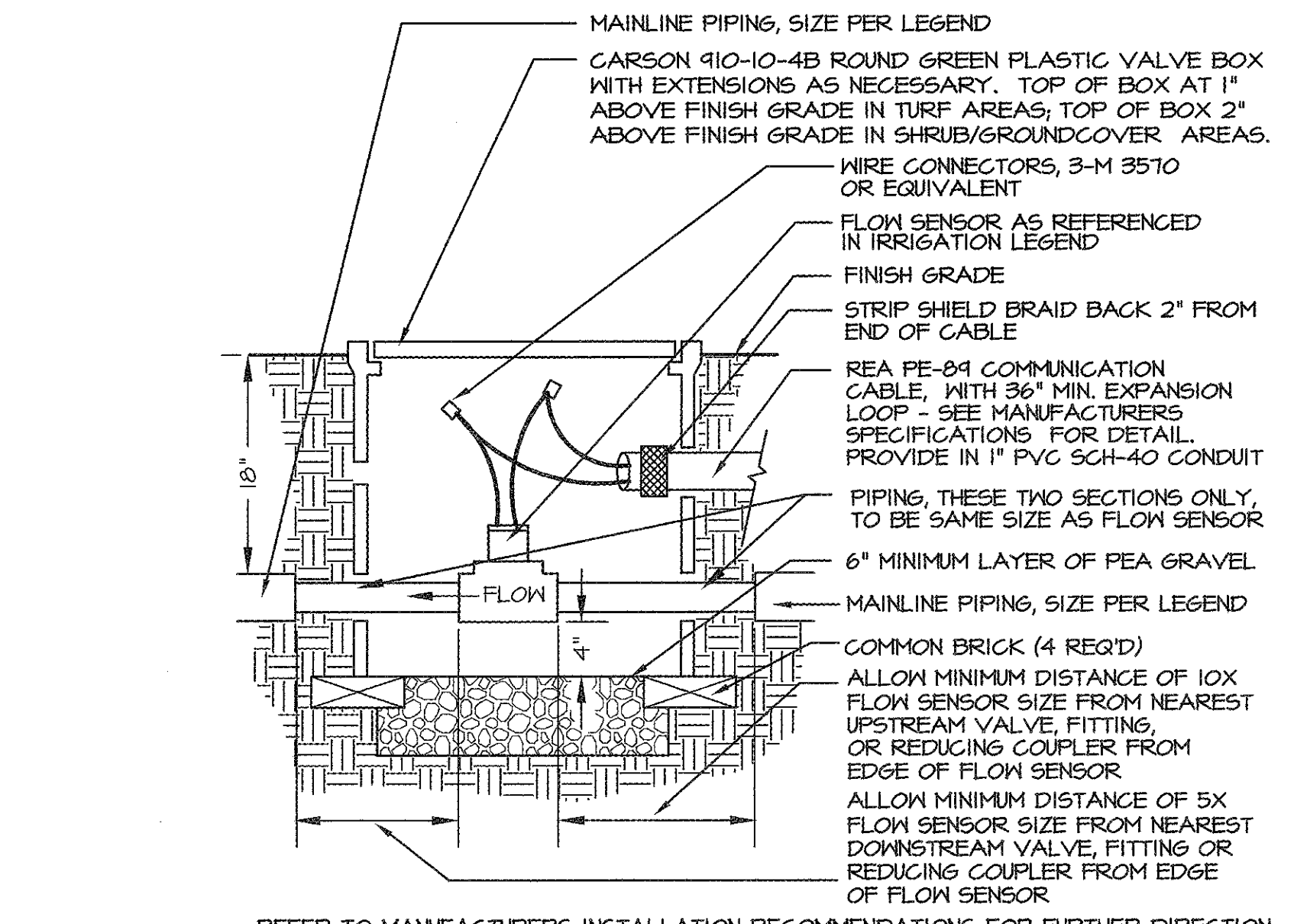

8 IRRIGATION FLOW SENSOR SCALE: NTS

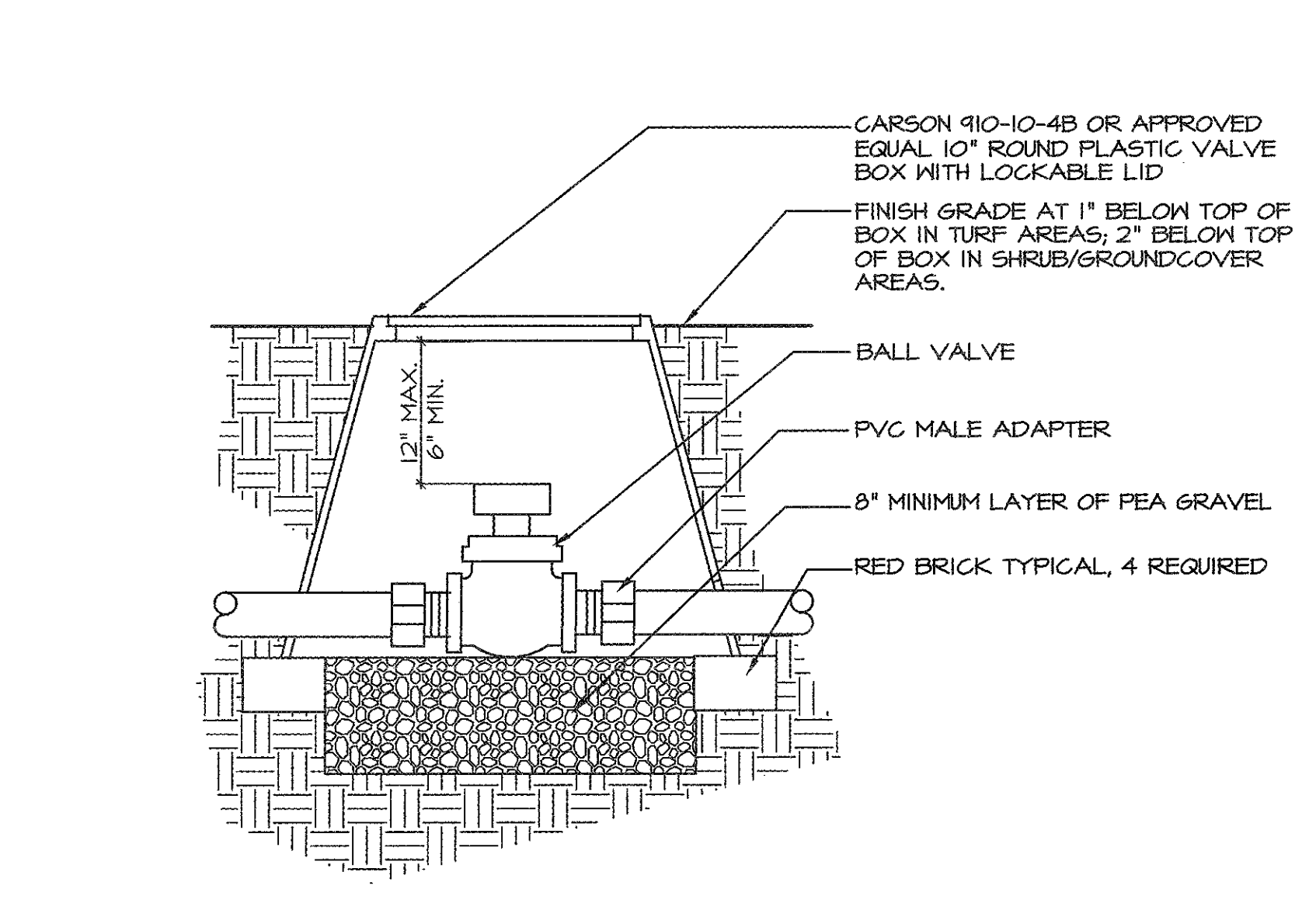

9 IRRIGATION BALL VALVE SCALE: NTS

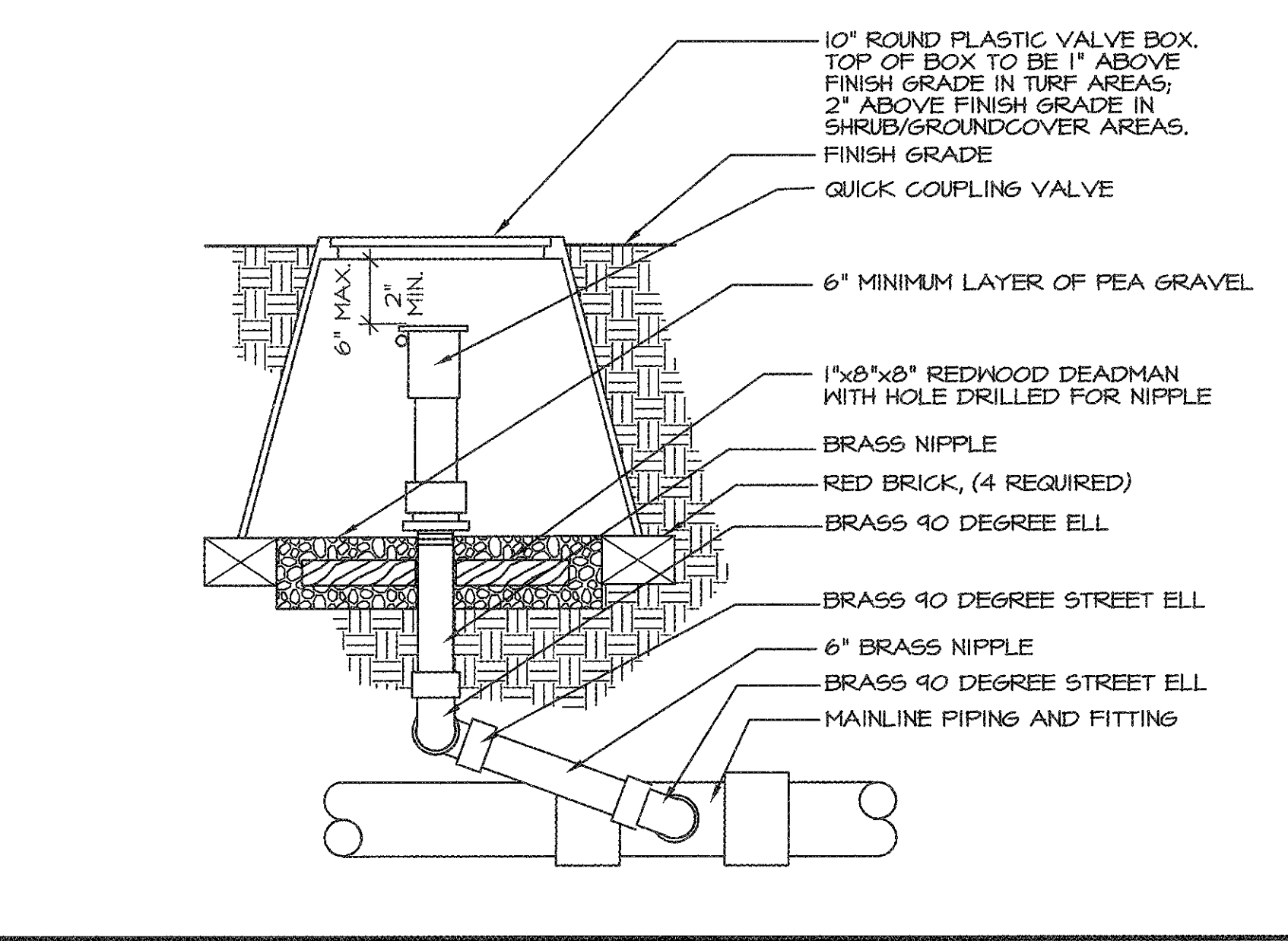

10 IRRIGATION QUICK COUPLING VALVE SCALE: NTS

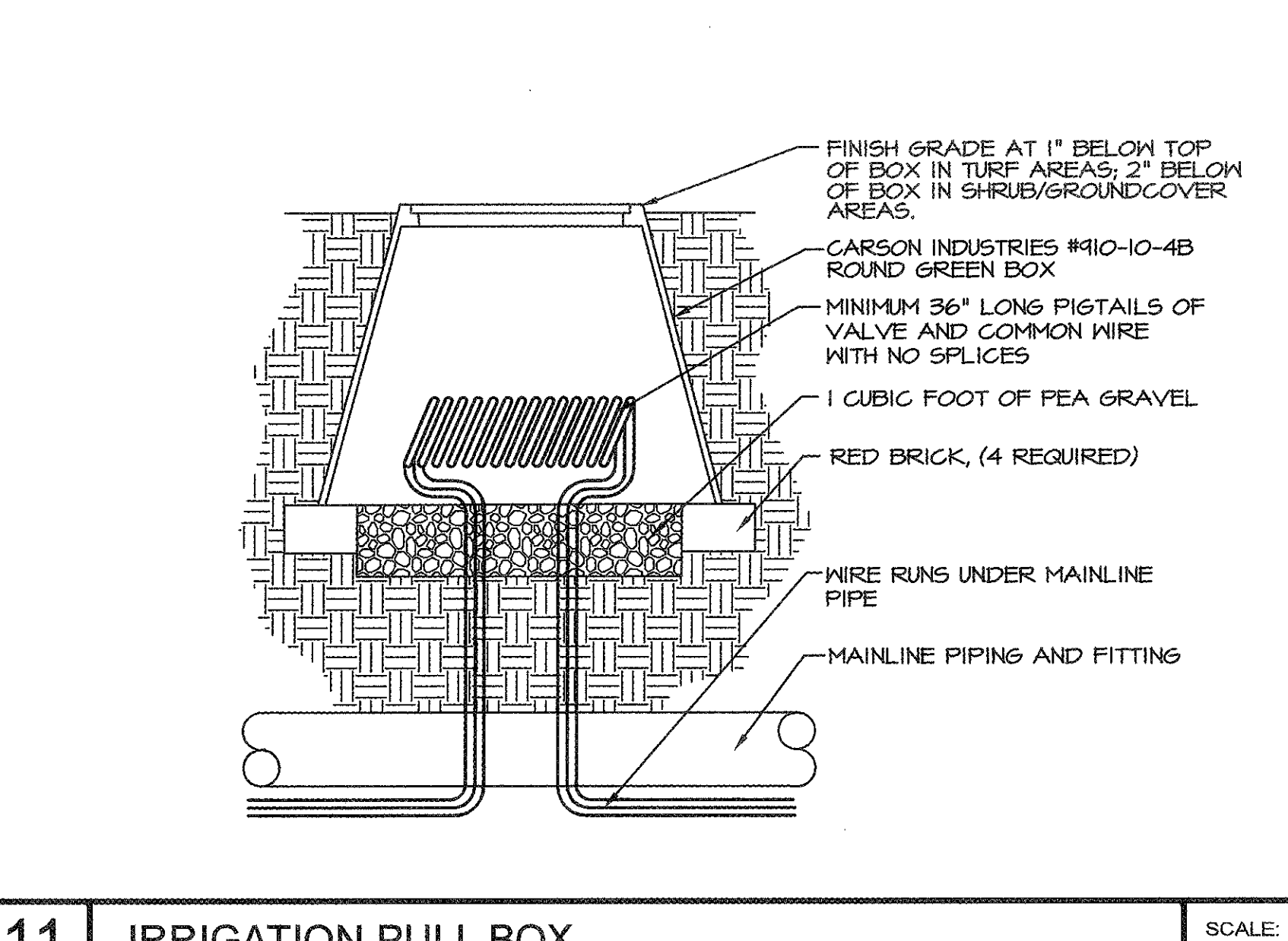

11 IRRIGATION PULL BOX SCALE: NTS

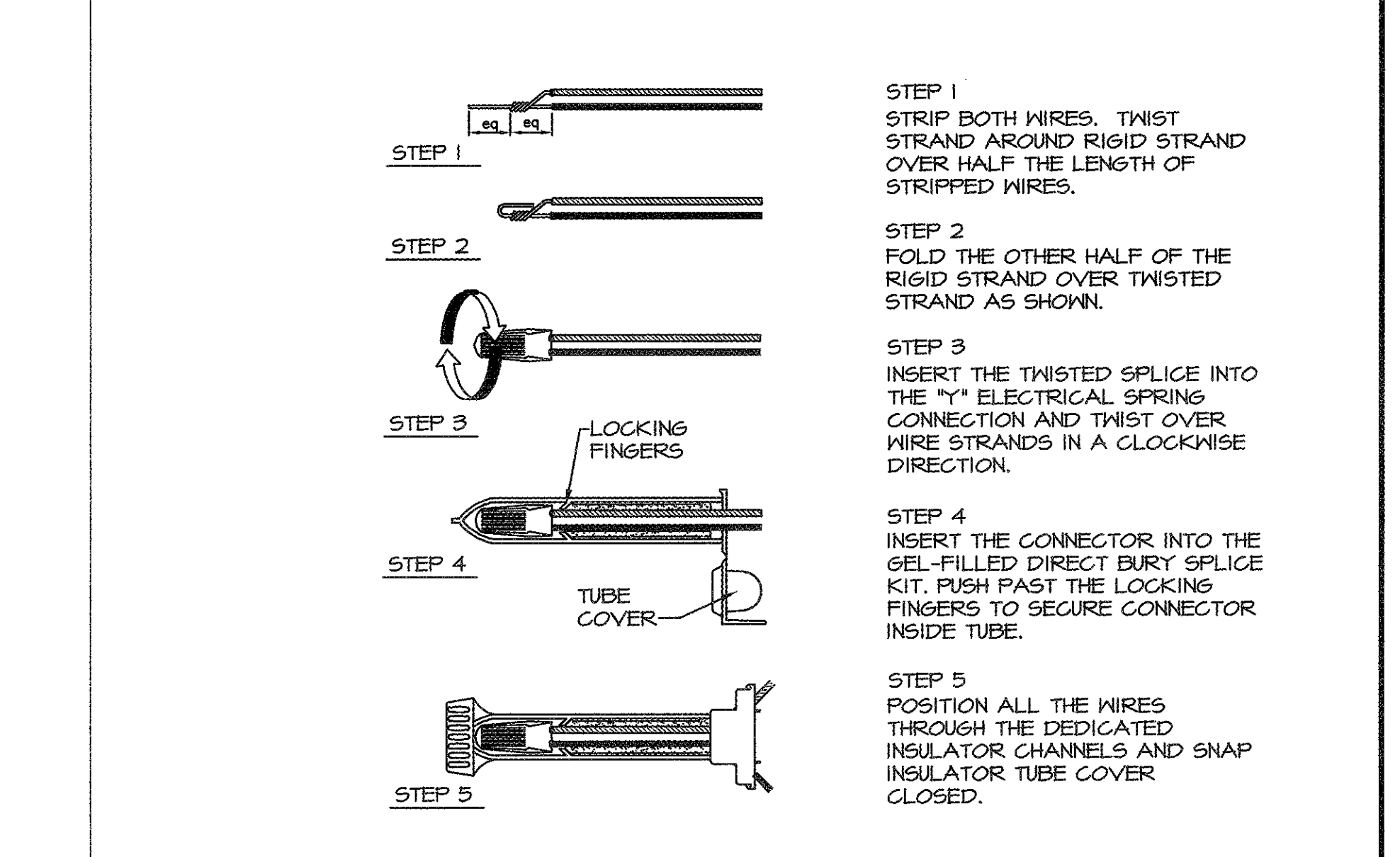

12 IRRIGATION WIRE CONNECTIONS SCALE: NTS

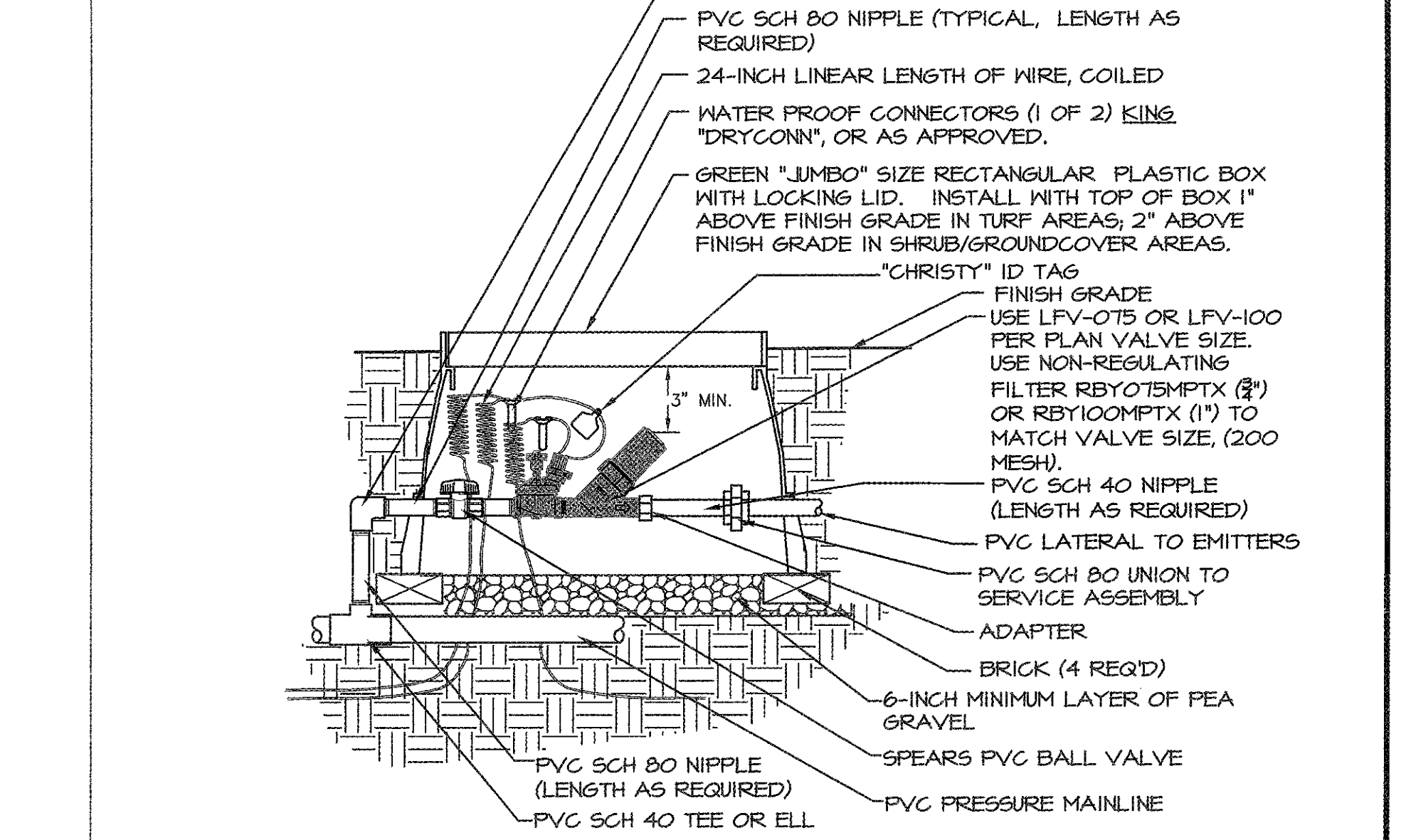

13 DRIP IRRIGATION ZONE KIT SCALE: NTS

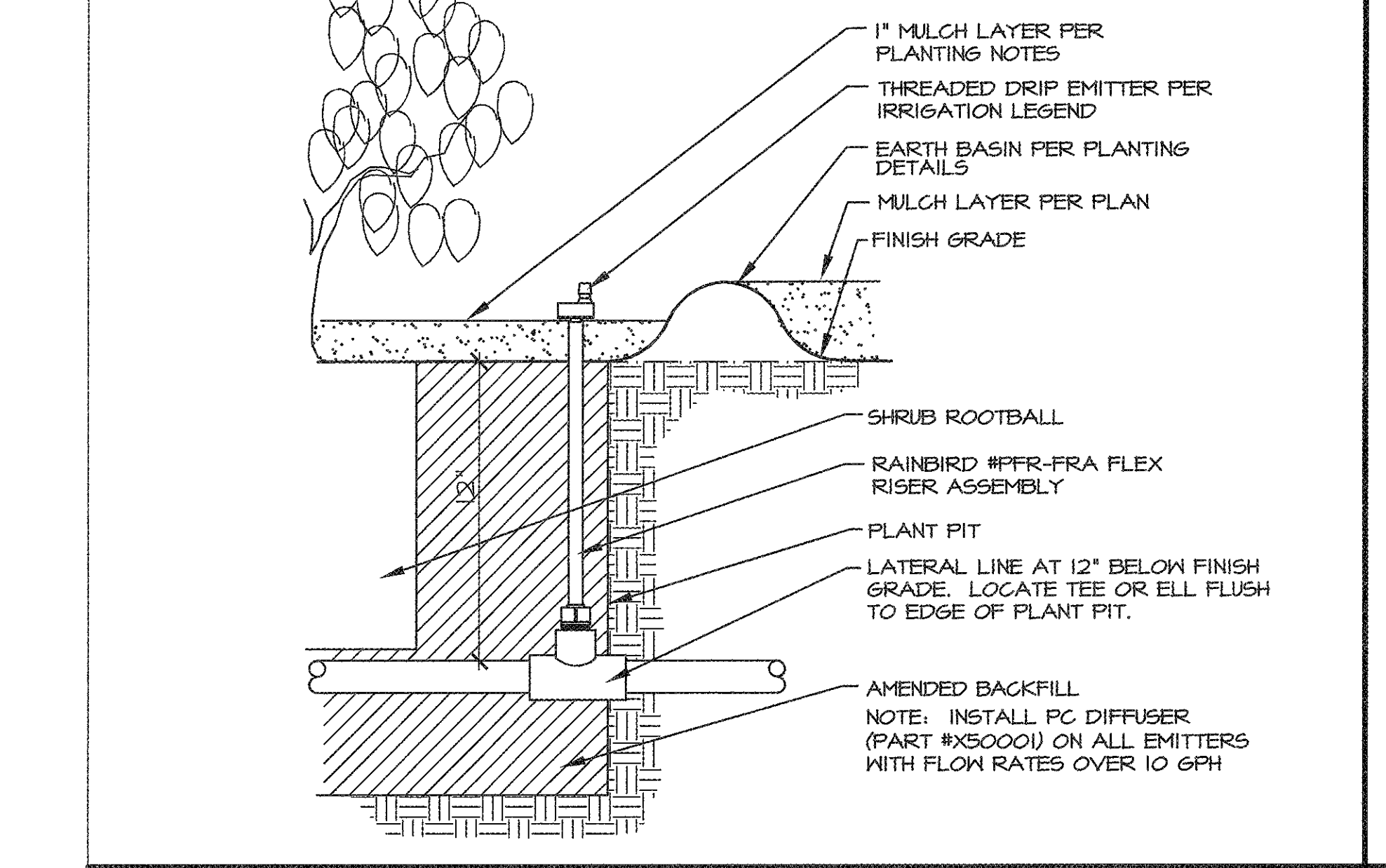

14 DRIP IRRIGATION EMITTER ON FLEX-RISER SCALE: NTS

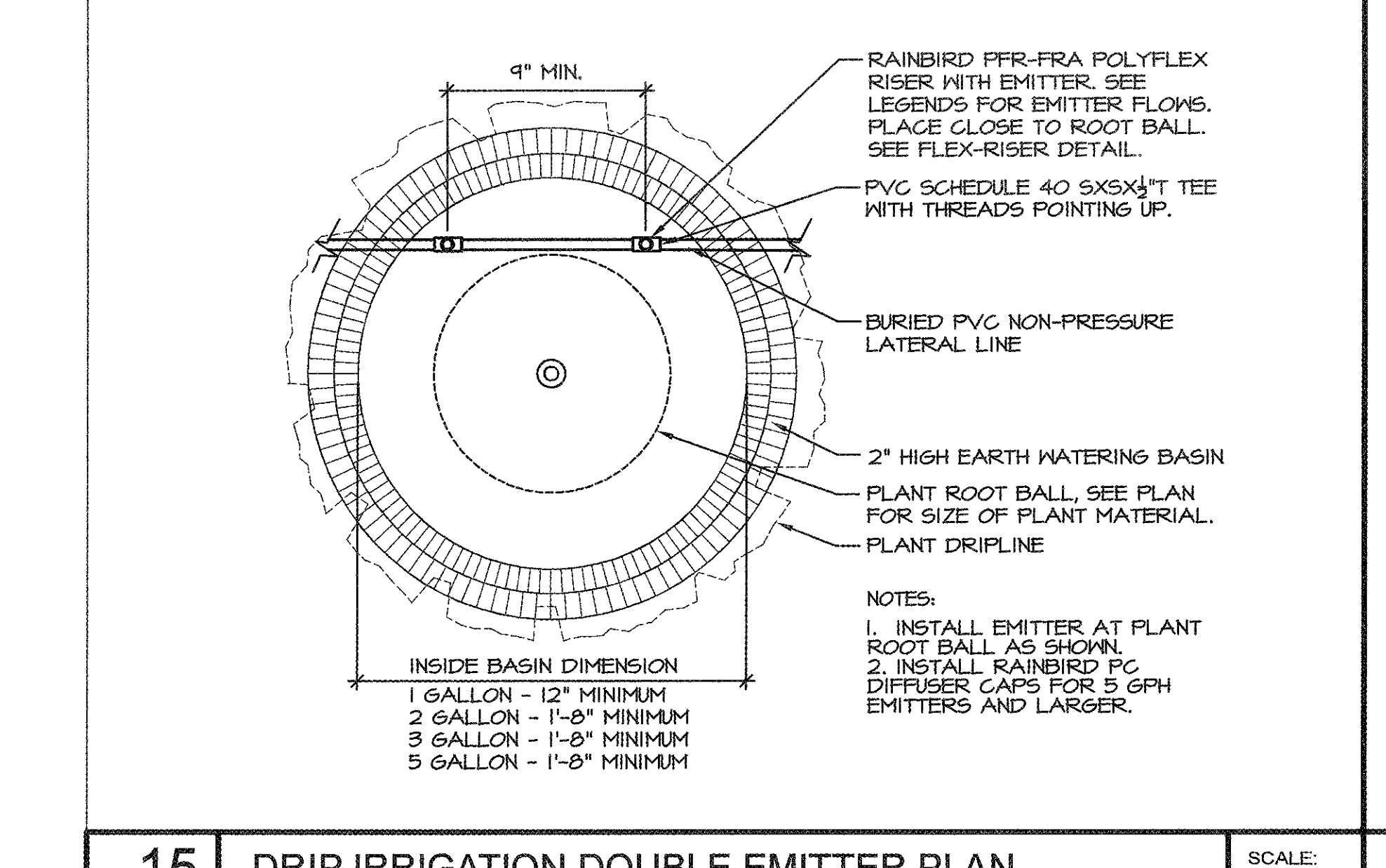

15 DRIP IRRIGATION DOUBLE EMITTER PLAN SCALE: NTS

TCLA, Inc.
LANDSCAPE ARCHITECTURE - ENVIRONMENTAL DESIGN

10 CORPORATE OFFICE, JOSEPHINA VIKONIA, ILL. CA#17737
2795 SMYTH DRIVE, VALENCIA, CALIFORNIA 91356
(PH) 861-702-1011 (FX) 861-702-0295

LANDSCAPE ARCHITECT
STATE OF CALIFORNIA

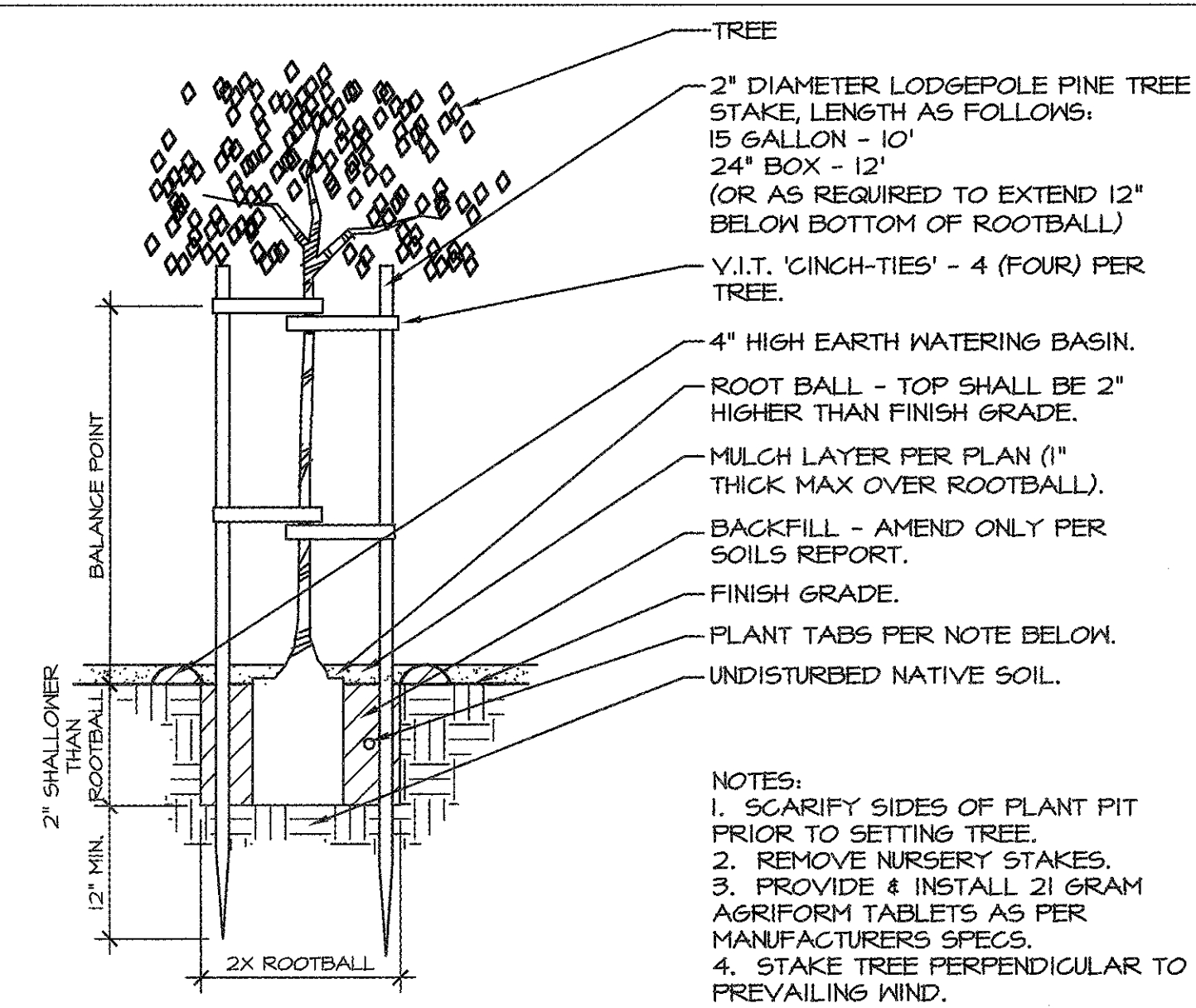

4 TREE DETAIL

SCALE: NTS

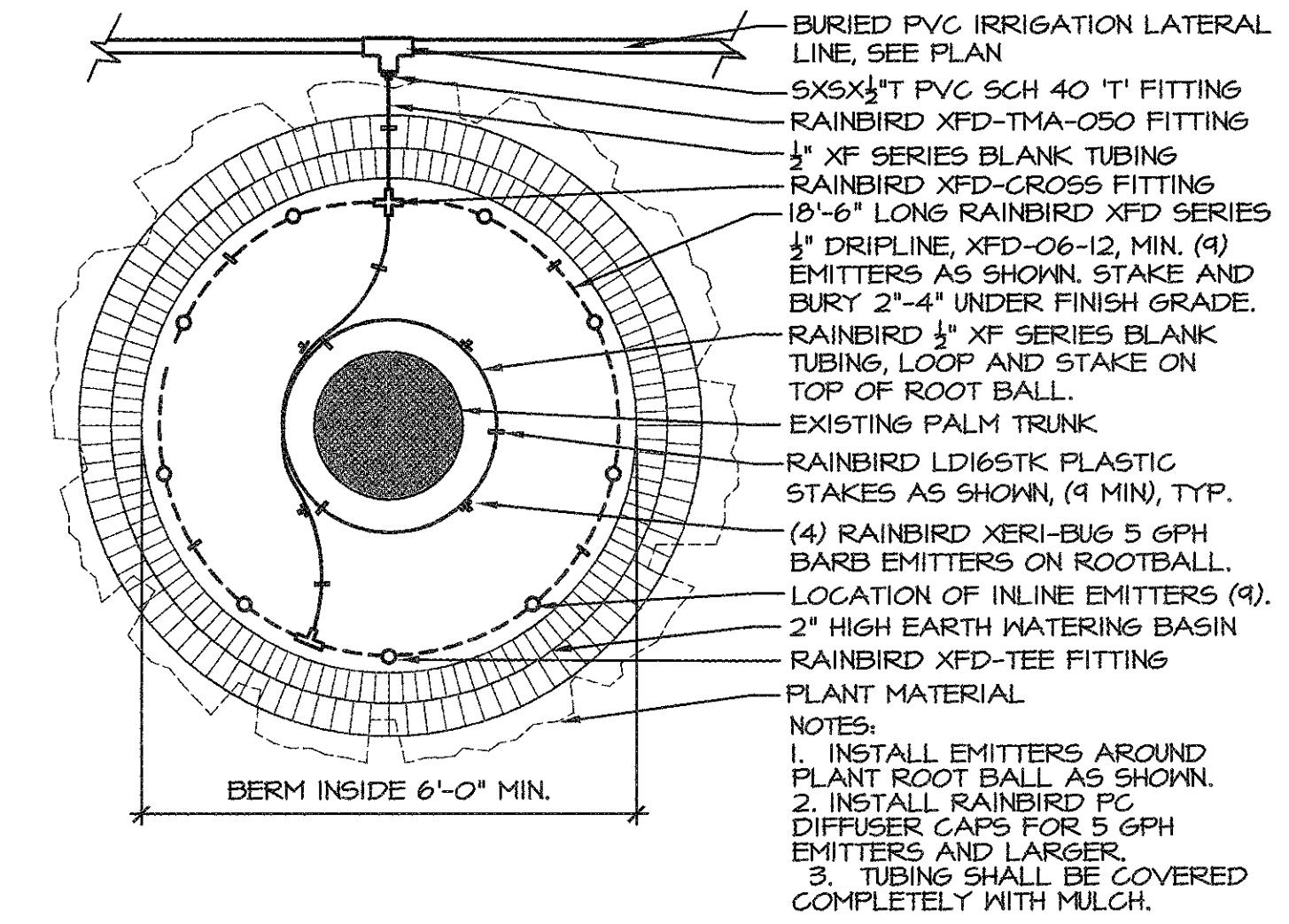

1 EXISTING PALM TREE IRRIGATION DETAIL

SCALE: 1"=1'-0"

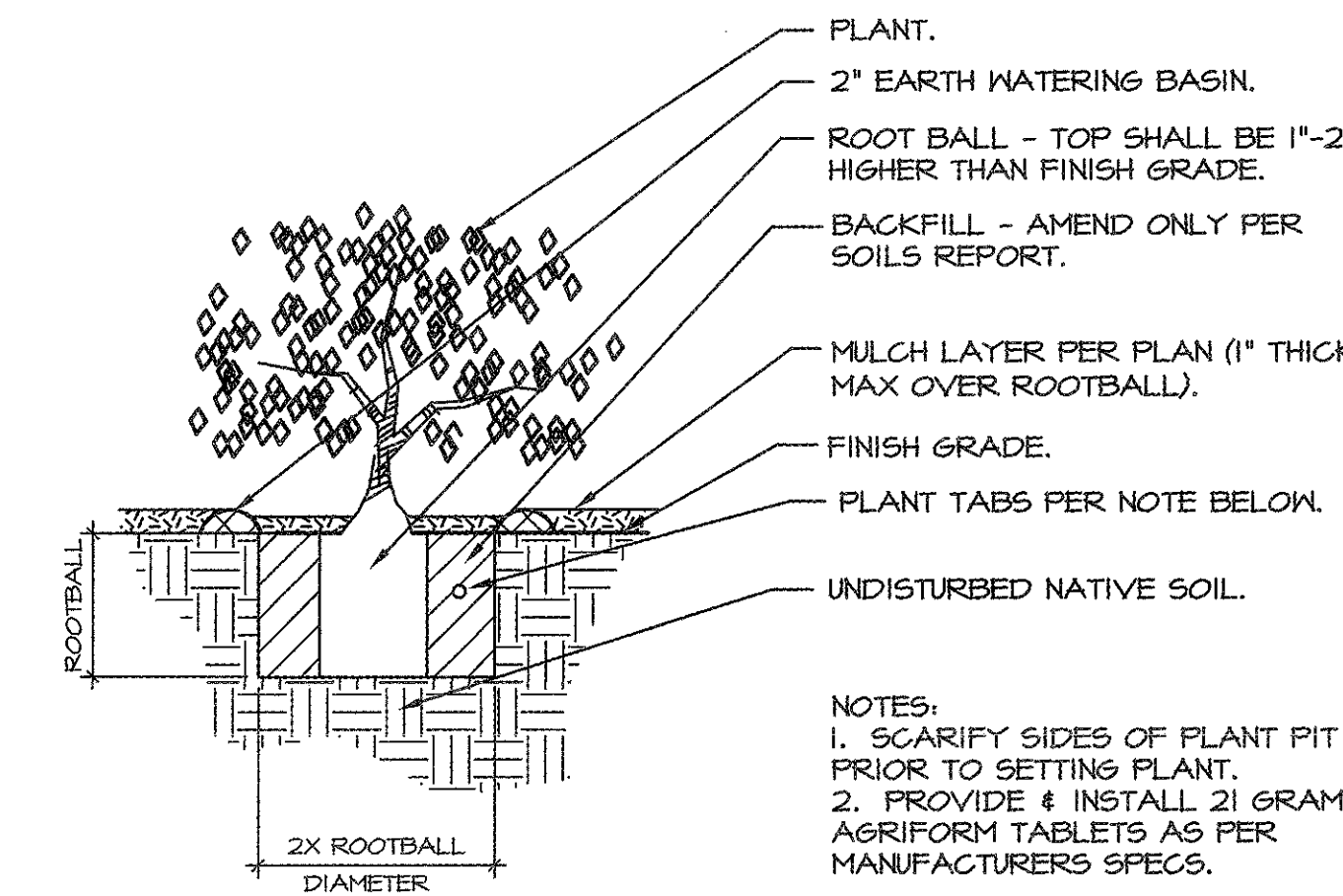

5 SHRUB DETAIL

SCALE: NTS

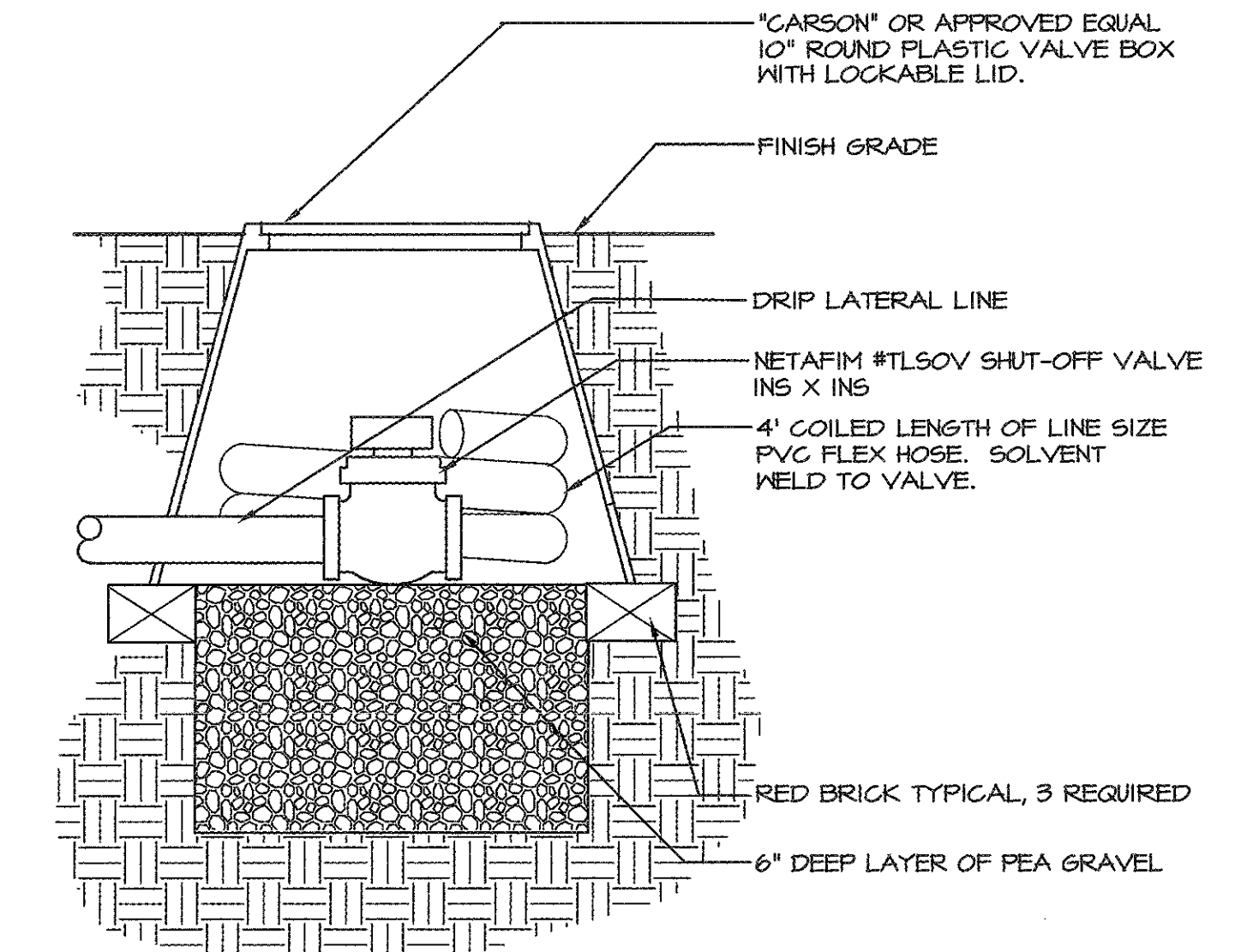

2 DRIP IRRIGATION FLUSH VALVE

SCALE: 1"=1'-0"

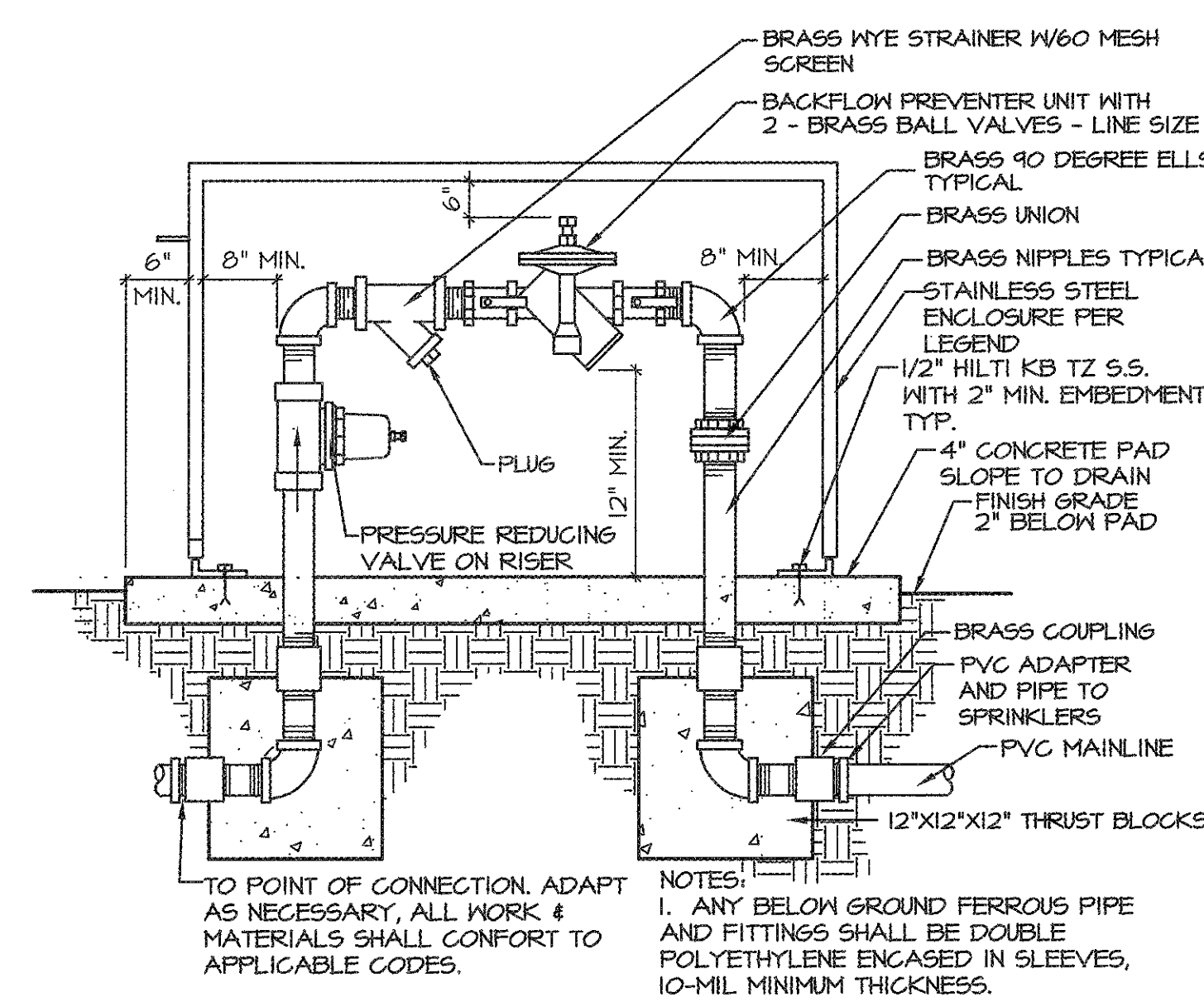

6 IRRIGATION RP BACKFLOW PREVENTER

SCALE: NTS

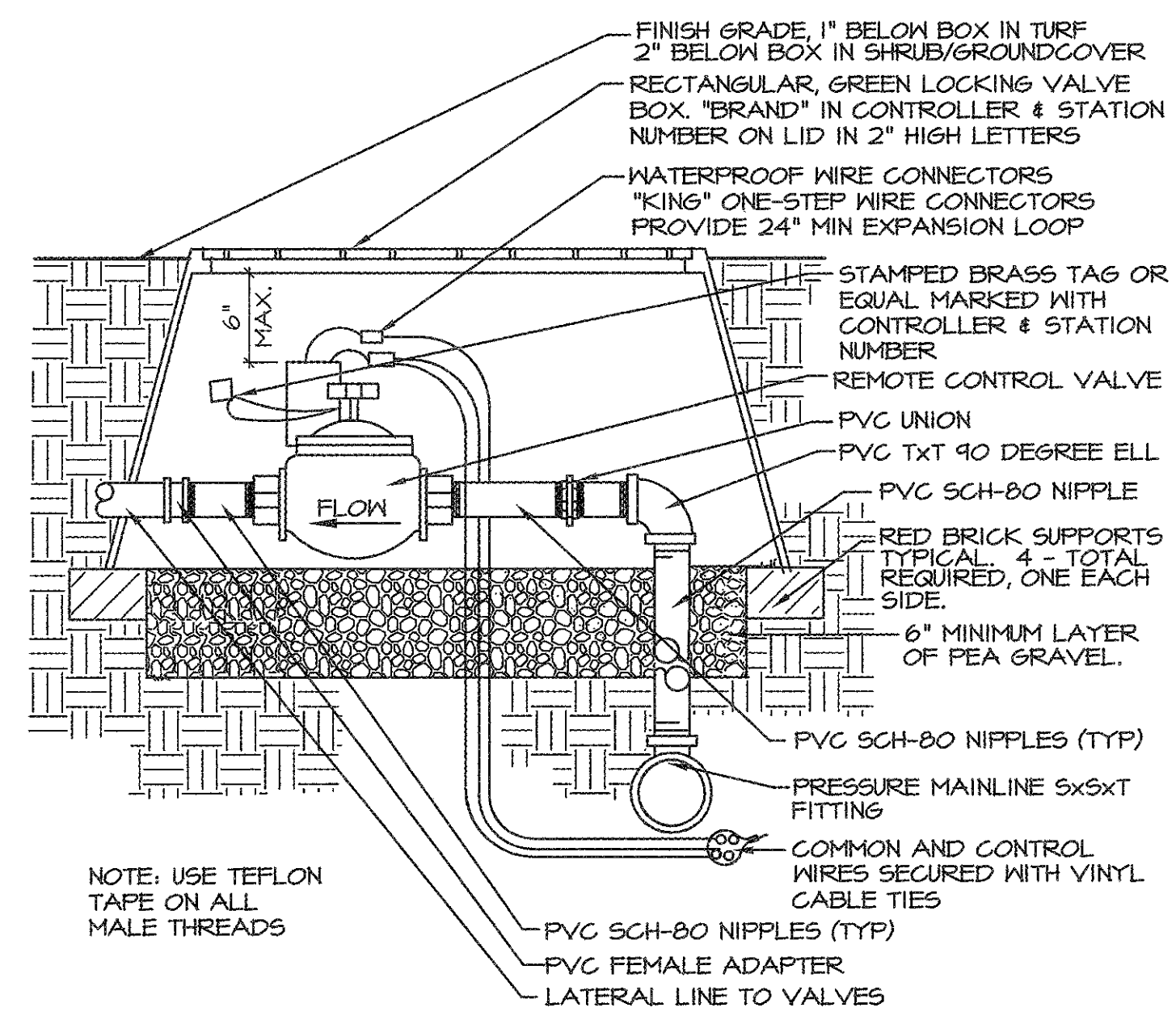

3 CONVENTIONAL REMOTE CONTROL VALVE

SCALE: NTS

GENERAL NOTES

- 1. FOR APPLICABLE CODES AND STANDARDS, REFER TO SHEET 00.1.1
2. DURING THE ENTIRE CONSTRUCTION PERIOD, IT SHALL BE THE SOLE RESPONSIBILITY OF THE CONTRACTOR TO MAINTAIN CONDITIONS AT THE PROJECT SITE...
3. CONFIRM ALL NEW AND EXISTING CONDITIONS WITH THE CONTRACT DOCUMENTS...
4. REVIEW THE ARCHITECTURAL DRAWINGS BEFORE THE INSTALLATION OF SYSTEMS...
5. DO NOT SCALE THE CONSTRUCTION DOCUMENTS...
6. CORRECT ALL WORK INSTALLED IN CONFLICT WITH THE CONSTRUCTION DOCUMENTS...
7. VISIT JOB SITE PRIOR TO BEGINNING WORK AND VERIFY ALL DIMENSIONS AND CONDITIONS...
8. SECURE AND PAY FOR ALL PERMITS, GOVERNMENTAL FEES AND LICENSES...
9. WHERE WORK OR EQUIPMENT IS INDICATED "N.I.C." (NOT IN CONTRACT) ON THE DRAWINGS...
10. ALL PLAN DIMENSIONS SHOWN AT CENTER OF WALL REPRESENT CENTER LINE OF MATERIAL...
11. ALL PLAN DIMENSIONS FOR MASONRY AND CONCRETE REPRESENT FACE OF MATERIAL...
12. ALL DIMENSIONS SHOWN ARE TO FACE OF STUD AT NEW CONSTRUCTION AND FACE OF FINISH AT EXISTING CONSTRUCTION...
13. DIMENSIONS ARE NOT ADJUSTABLE WITHOUT THE REVIEW OF ARCHITECT UNLESS NOTED "(H)" OR "VERIFY"...
14. ALL HEIGHTS ARE DIMENSIONED FROM TOP OF SLAB UNLESS NOTED "AFF" (ABOVE FINISH FLOOR)...
15. "TYPICAL" MEANS COMPARABLE CHARACTERISTICS FOR THE ELEVATION OR DETAIL NOTED...
16. PROVIDE WORK NOT SPECIFICALLY DETAILED OR SPECIFIED IN ACCORDANCE WITH DETAILS OR SIZES COVERING SIMILAR WORK...
17. "SIMILAR" MEANS COMPARABLE CHARACTERISTICS FOR THE ELEVATION OR DETAIL NOTED...
18. ABBREVIATIONS THROUGHOUT THE DOCUMENTS COMPLY WITH DOCUMENT ABBREVIATION LIST...
19. REFER TO THE PROJECT MANUAL FOR GENERAL CONDITIONS, SUPPLEMENTARY AND SPECIAL CONDITIONS...
20. PROVIDE BARRICADES AND PROTECTIVE DEVICES SEPARATING CONSTRUCTION AREAS...
21. PROVIDE FOR THE PROPER SEQUENCE OF CONSTRUCTION, LOCATION AND SIZE OF OPENINGS...
22. TAKE ALL MEASURES TO ACCOMPLISH THE WORK WITH THE MINIMUM OF INTERRUPTION TO NORMAL BUILDING PROCEDURES...
23. REMOVE ALL TRASH AND DEBRIS DAILY...
24. PERFORM ALL CUTTING, PATCHING, AND FINISHING NECESSARY TO RESTORE THE BUILDING AND SITE...
25. VERIFY POINTS OF CONNECTION, INCLUDING SIZES AND LOCATIONS...
26. COORDINATE THE LOCATION AND TYPE OF ALL ACCESS PANELS...
27. CONTRACTOR SHALL STIPULATE THAT ALL PROPOSED SUBSTITUTIONS ARE EQUAL IN PERFORMANCE...
28. CONTRACTOR SHALL INSURE ALL CONSTRUCTION SHALL REMAIN ACCESSIBLE AND EXPOSED FOR INSPECTION...
29. PROTECTION DURING WELDING...
30. WASTE OILS AND FLUIDS MUST BE PROPERLY COLLECTED AND REMOVED FROM THE SITE.

DSA NOTES

- 1. ALL WORK TO CONFORM TO 2013 EDITION TITLE 24, CALIFORNIA CODE OF REGULATIONS (CCR).
2. CHANGES TO THE APPROVED DRAWINGS OR SPECIFICATIONS SHALL BE MADE BY AN ADDENDA OR A CONSTRUCTION CHANGE DOCUMENT (C.C.D.) APPROVED BY THE DIVISION OF THE STATE ARCHITECT (DSA) PER SECTION 4-338, PART 1, TITLE 24, CCR.
3. A DSA ACCEPTED TESTING LABORATORY DIRECTLY EMPLOYED BY THE DISTRICT (OWNER) SHALL CONDUCT ALL THE REQUIRED TESTS AND INSPECTIONS FOR THE PROJECT.
4. GRADING PLANS, DRAINAGE IMPROVEMENTS, ROADS AND ACCESS REQUIREMENTS NAD ENVIRONMENTAL HEALTH CONSIDERATIONS SHALL COMPLY WITH ALL LOCAL ORDINANCES.

EQUIPMENT ANCHORAGE

EQUIPMENT ANCHORAGE NOTES:
ALL MECHANICAL AND ELECTRICAL EQUIPMENT SHALL BE ANCHORED OR BRACED TO MEET THE HORIZONTAL AND VERTICAL FORCES PRESCRIBED IN THE 2013 CBC, SECTION 1615A, 1616A, ASCE 7-10 AND CHAPTER 6.
THE ATTACHMENT OF THE FOLLOWING ITEMS SHALL BE DESIGNED TO RESIST THE FORCES PRESCRIBED ABOVE, BUT NEED NOT BE DETAILED ON THE PLANS, AND THE PROJECT INSPECTOR WILL VERIFY THAT THESE ITEMS (EQUIPMENT) HAVE BEEN ANCHORED.
A. EQUIPMENT WEIGHING LESS THAN 400 POUNDS SUPPORTED DIRECTLY ON THE FLOOR OR ROOF.
B. FURNITURE REQUIRED TO BE ATTACHED IN ACCORDANCE WITH ASCE 7-05 SECTION 13.5
C. TEMPORARY OR MOVABLE EQUIPMENT WITH FLEXIBLE CONNECTION TO POWER OR UTILITIES
D. EQUIPMENT WEIGHING LESS THAN 200 POUNDS SUPPORTED BY VIBRATION ISOLATORS
E. EQUIPMENT WEIGHING LESS THAN 20 POUNDS SUSPENDED FROM A ROOF OR HUNG FROM A WALL
FOR THOSE ELEMENTS THAT DO NOT REQUIRE DETAILS ON THE APPROVED DRAWINGS, THE INSTALLATION SHALL BE SUBJECT TO THE APPROVAL OF THE MECHANICAL/ELECTRICAL
PIPING, DUCTWORK & ELECTRICAL DISTRIBUTION SYSTEM BRACING NOTE
PIPING, DUCTWORK AND ELECTRICAL DISTRIBUTION SYSTEMS SHALL BE BRACED TO RESIST THE FORCES PRESCRIBED IN ASCE 7-05 SECTION 13.3 AS DEFINED IN ASCE 7-10 SECTION 13.8.8, 13.8.7, 13.8.5.1 ITEM 6, AND 2013 CBC 1615A AND 1616A.
THE BRACING AND ATTACHMENTS TO THE STRUCTURE SHALL COMPLY WITH 2013 CBC 1613A.
THE STRUCTURAL ENGINEER OF RECORD SHALL VERIFY THE ADEQUACY OF THE STRUCTURE TO SUPPORT THE HANGER AND BRACE LOADS.

FINISH NOTES

- 1. ALL CEILING HEIGHT DIMENSIONS MEASURED TO FINISH SURFACES UNLESS NOTED OTHERWISE.
2. EXTEND BASE MATERIAL BEHIND ALL MOVABLE EQUIPMENT AND INTO ALL ALCOVES, KNEESPACES AND SIMILAR AREAS, UNLESS NOTED OTHERWISE.
3. WHEN COUNTERTOP SPLASH IS REQUIRED, EXTEND SPLASH ON SIDES WHERE COUNTER JOINS ADJACENT WALL SURFACE UNLESS NOTED OTHERWISE.
4. ALL INTERIOR FINISHES SHALL COMPLY WITH CHAPTERS 8 AND 25A, PART 2, TITLE 24, CCR, INCLUDING TABLE 8-A, AND TABLES 25A-25L.
5. PROVIDE BACKING PLATES OR BLOCKING BEHIND ALL WALL MOUNTED EQUIPMENT, CASEWORK, AND ACCESSORIES AS REQUIRED FOR POSITIVE ATTACHMENT TO STRUCTURE. SEE DETAILS 3 & 6S1.3.
6. SEAL ALL PENETRATIONS OF SOUND RATED PARTITIONS, FLOORS OR CEILING ASSEMBLIES INCLUDING ELECTRICAL DEVICES, CABINETS AND OTHER ELEMENTS WITH APPROVED RESILIENT SEALANT. SEE AGENCY NOTES FOR PENETRATION REQUIREMENTS OF FIRE RATED AND SOUND RATED ASSEMBLIES.

STRUCTURAL NOTES

- 1. SUPPORT AND BRACE ALL PIPES, DUCTS, AND CONDUITS PER APPROPRIATE DETAIL ON ARCHITECTURAL DETAIL SHEET(S) AND THE FOLLOWING STANDARDS OR APPROVED EQUAL:
* SMACNA SEISMIC RESTRAINT MANUAL
2. PROVIDE ALL TEMPORARY SHORING AND BRACING AS REQUIRED FOR ALL DEMOLITION AND NEW WORK AS REQUIRED. ASSUME FULL RESPONSIBILITY FOR REPAIR AND/OR REPLACEMENT OF DAMAGED AREAS, INCLUDING BUT NOT NECESSARILY LIMITED TO, STRUCTURE, FINISHES, EQUIPMENT AND FURNISHINGS IF DAMAGE OF ANY KIND OCCURS AS RESULT OF IMPROPER OR INADEQUATE SHORING OR BRACING.
3. UNLESS SPECIFICALLY DETAILED ON STRUCTURAL DRAWINGS, DO NOT CUT OR OTHERWISE MODIFY STRUCTURAL ELEMENTS WITHOUT DIRECTION FROM ARCHITECT. PROVIDE REINFORCEMENT SUPPORT TEMPORARY SHORING SATISFACTORY TO THE ARCHITECT AND STRUCTURAL ENGINEER PRIOR TO CUTTING INTO STRUCTURAL PORTIONS OF ANY BUILDING ELEMENT. PROVIDE ALL CUTTING OF STRUCTURAL ELEMENTS, AND ALL ASSOCIATED REPAIR OR REFINISHING OF ADJACENT SURFACES AT NO ADDITIONAL EXPENSE TO THE OWNER.
4. WHEN INSTALLING DRILLED-IN ANCHORS AND/OR POWER DRIVEN PINS IN EXISTING NON-PRE-STRESSED REINFORCED CONCRETE, USE CARE AND CAUTION TO AVOID CUTTING OR DAMAGING EXISTING REINFORCING BARS. WHEN INSTALLING DRILLED-IN ANCHORS AND/OR POWER DRIVEN PINS IN EXISTING PRE-STRESSED REINFORCED CONCRETE (POST OR PRE TENSIONED), USE A NON-DESTRUCTIVE METHOD TO LOCATE TENDONS PRIOR TO INSTALLATION. EXERCISE EXTREME CARE AND CAUTION TO AVOID CUTTING OR DAMAGING THE TENDONS DURING INSTALLATION. MAINTAIN A MINIMUM CLEARANCE OF ONE INCH BETWEEN THE REINFORCEMENT AND THE DRILLED-IN ANCHOR AND/OR PIN.
5. PROVIDE TEMPORARY SHORING FOR EXCAVATIONS THAT REMOVE THE LATERAL SUPPORT FROM AN EXISTING BUILDING OR A PUBLIC WAY. PRIOR TO ISSUANCE OF PERMIT, OBTAIN APPROVAL FROM THE ENFORCING AGENCY FOR EXCAVATIONS ADJACENT TO A PUBLIC WAY.
6. OBTAIN NECESSARY PERMITS, INCLUDING CALIFORNIA DIVISION OF INDUSTRIAL SAFETY, PRIOR TO ISSUANCE OF A BUILDING OR GRADING PERMIT FOR ALL TRENCHING.

FIRE & LIFE SAFETY NOTES

- 1. ALL INTERIOR FINISHES SHALL CONFORM TO THE REQUIREMENTS OF CHAPTER 8, PART 2, TITLE 24, CCR. ALL FINISHES SHALL HAVE A FLAME SPREAD RATING OF 75 OR LESS AND A SMOKE DENSITY NOT TO EXCEED 450 WHEN TESTED IN ACCORDANCE WITH U.B.C. STANDARDS NO. 8-1, AND SHALL HAVE A CLASS I OR II FLAME SPREAD CLASSIFICATION PER TABLE 8-A.
2. ALL INSULATION MATERIALS INSTALLED WITHIN ROOF - CEILING ASSEMBLIES, ATTICS, OR WALLS SHALL HAVE A FLAME - SPREAD RATING NOT TO EXCEED 25 AND A SMOKE DENSITY NOT TO EXCEED 450 WHEN TESTED IN ACCORDANCE WITH U.B.C. STANDARD NO. 8-1.
3. MANUFACTURERS INSTALLATION INSTRUCTIONS SHALL BE AVAILABLE ON THE JOB SITE FOR ALL RATED OPENING ASSEMBLIES.
4. PROVIDE A PORTABLE FIRE EXTINGUISHER WITH A RATING OF NOT LESS THAN 2-A-10BC WITHIN A 75 FOOT TRAVEL DISTANCE TO ALL PORTIONS OF THE BUILDING ON EACH FLOOR.
5. PROVIDE A PORTABLE FIRE EXTINGUISHER WITH A RATING OF NOT LESS THAN 1-BC FOR ELECTRICAL ROOMS, MECHANICAL ROOMS, ELEVATOR MACHINE ROOMS AND TRASH ROOMS.
6. PROVIDE AN APPROPRIATE NUMBER OF PORTABLE FIRE EXTINGUISHERS WITH A RATING OF NOT LESS THAN 4A-60BC FOR PROTECTION DURING CONSTRUCTION.
7. THE CONTRACTOR SHALL PROVIDE AND INSTALL TEMPORARY PEDESTRIAN PROTECTION AS REQUIRED BY LOCAL CODE AND SPECIFICATION.
8. DO NOT BLOCK EXITS AT ANY TIME.
9. PROVIDE FIRE DAMPERS AT ALL DUCT PENETRATIONS OF FIRE RATED WALLS, FLOORS, SHAFTS AND CEILINGS. COMBINATION FIRE/SMOKE DAMPERS SHALL BE USED AT DUCT PENETRATIONS OF RATED CORRIDOR WALLS.
10. FIRE DAMPER DETAILS SHOWN FOR REFERENCE ONLY. FIRE DAMPERS SHALL BE APPROVED AND LISTED BY STATE FIRE MARSHAL. INSTALL STRICTLY PER MANUFACTURER'S PRINTED INSTRUCTIONS AND LISTING APPROVAL. MANUFACTURER'S INSTALLATION INSTRUCTIONS SHALL BE MADE AVAILABLE TO THE INSPECTING AUTHORITIES.
11. DUCT INSULATION APPLIED TO THE EXTERIOR SURFACE OF DUCTS LOCATED IN BUILDINGS SHALL HAVE A FLAME SPREAD OF NOT MORE THAN 25 AND A SMOKE-DEVELOPED RATING OF NOT MORE THAN 50 WHEN TESTED AS A COMPOSITE INSTALLATION INCLUDING INSULATION, FACING MATERIALS, TAPES AND ADHESIVES AS NORMALLY APPLIED.
12. THE FIRE ALARM SYSTEM SHALL CONFORM TO ARTICLE 760 OF THE CALIFORNIA ELECTRICAL CODE, STANDARDS AS DEFINED IN CHAPTER 35 CALIFORNIA BUILDING CODE AND APPLICABLE NFPA STANDARDS.
13. THE CONTRACTOR SHALL PROVIDE PROTECTION COMPLYING WITH TITLE 8, CCR, DURING WELDING. FURTHER PROTECTION SHALL BE PROVIDED TO ANY OCCUPANTS AND THE PUBLIC WITH PORTABLE SOLID VISION BARRICADES AROUND LOCATION WHERE WELDING IS BEING PERFORMED. PROVIDE SIGNS WARNING AGAINST LOOKING AT WELDING WITHOUT PROPER EYE PROTECTION OR EQUIVALENT.

LITTLE ARCHITECTURAL CONSULTING
1300 Dove Street, Suite 100
Newport Beach, CA 92660
T: 949.698.1400 F: 949.698.1433
www.littleonline.com
COMPTON CCD
CAMPUS PUBLIC SAFETY BUILDING
1111 EAST ARTESIA BOULEVARD,
COMPTON CALIFORNIA 90221
IDENTIFICATION STAMP
DIV. OF THE STATE ARCHITECT
OFFICE OF REGULATION SERVICES
FILE NO: 19-C1
AR: 03-117673
AC, PE, FS, DS, PO
DATE: DEC. 1, 2011
PRINCIPAL IN CHARGE
RITA S. CARTER
PROJECT MANAGER
SHOJI TAKESHIMA / DAVID PHAN
DRAWN BY
DAVID PHAN
NO REASON DATE
913-4675-00
12/01/16 A0.0.1

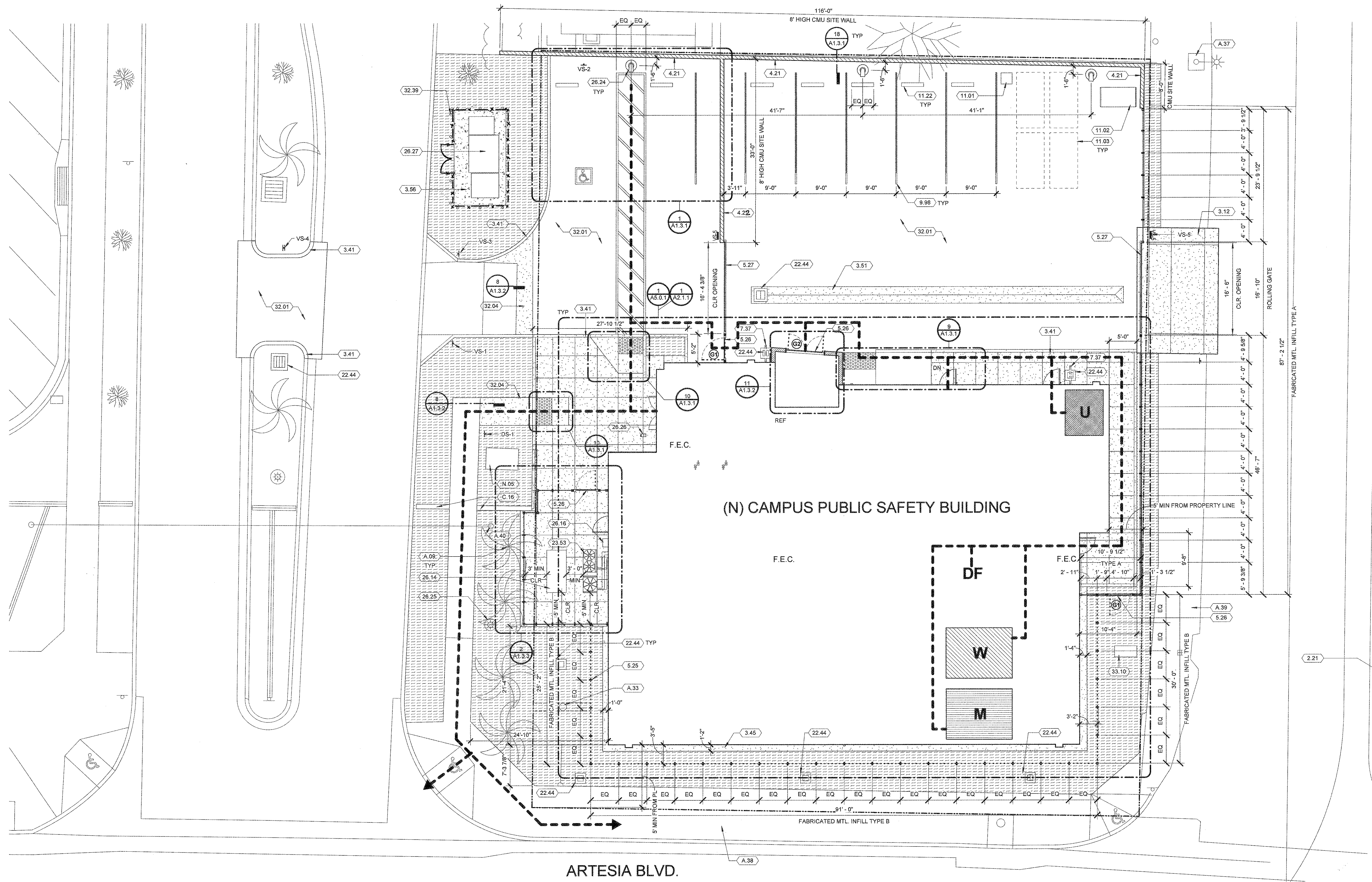

- KEYNOTES**
- 2.21 (E) FIRE HYDRANT
 - 3.12 CONCRETE DRIVEWAY, PER CIVIL - 32 13 13
 - 3.41 CAST-IN-PLACE CONCRETE CURB PER CIVIL, SEE DET 5/A1.3.2 FOR ADD. INFO - 32 13 13
 - 3.45 CAST IN PLACE CONCRETE MOW STRIP, SEE SIM. DET 1/A1.3.2 - 32 13 13
 - 3.51 CONCRETE SWALE, PER CIVIL - 32 13 13
 - 3.56 CONCRETE PAD, SEE CIVIL
 - 4.21 CONCRETE MASONRY UNIT SITE WALL PER 9/SS/2 & METAL COPING CAP PER DETAIL 5/A9.1.1 - 04 22 00
 - 4.22 CMU SITE WALL PER 12/E5.2
 - 5.25 FABRICATED STEEL FENCE - 32 13 17
 - 5.26 FABRICATED STEEL GATE - 32 13 17
 - 5.27 FABRICATED STEEL ROLLING GATE, SEE SHEET A1.3.3 - 05 50 00
 - 7.37 METAL DOWNSPOUT - 07 60 00
 - 9.98 PARKING STRIPING - 32 17 23
 - 11.01 AIR COMPRESSOR, SEE PLUMBING
 - 11.02 3 YARD DUMPSTER, NIC
 - 11.03 GOLF CART PARKING LOCATION, GOLF CARTS NIC
 - 11.22 PARKING WHEEL STOP, SEE DET. 6/A1.3.1 - 32 17 13
 - 22.44 CATCH BASIN, PER CIVIL
 - 23.53 HVAC CONDENSING UNIT, PER MECHANICAL - 23 65 00
 - 26.14 EMERGENCY GENERATOR, PER ELECTRICAL
 - 26.16 IRRIGATION CONTROL PANEL, PER LANDSCAPING & ELECTRICAL
 - 26.24 SITE POLE LIGHTING & CONCRETE BASE PER 7/E0.0.6, TYP., SEE ELECTRICAL
 - 26.25 O.I.C.F. SITE POLE LIGHTING & CONCRETE BASE PER 7/E0.0.6, TYP., SEE ELECTRICAL
 - 26.26 AUTOMATIC DOOR OPERATOR, SEE ELECTRICAL & DETAIL 3/A1.3.3
 - 26.27 SUBSTATION, REFER TO ELECTRICAL
 - 32.01 ASPHALT PAVING, PER CIVIL
 - 32.04 CONCRETE PAVING, REFER TO 3/A1.3.2 - 32 13 13
 - 32.39 PROTECTIVE BOLLARDS - 32 39 13
 - 33.10 BACKFLOW PREVENTER & ENCLOSURE, PER CIVIL
 - A.09 (E) TREE AND ROOTS TO REMAIN, COORDINATE ALL LANDSCAPE PROTECTION WITH LANDSCAPE TO REMAIN, PROTECT IN PLACE.
 - A.33 (E) UTILITY COMPANY POWER POLE AND BRACE TO REMAIN, PROTECT IN PLACE.
 - A.37 (E) SITE LIGHTING & BASE TO PROTECT IN PLACE
 - A.38 (E) CITY SIDEWALK
 - A.39 (E) CITY RIGHT OF WAY
 - A.40 (E) SIGNAGE POLE TO REMAIN, PROTECT IN PLACE
 - C.16 EXISTING BRICK VENEER WALL & ASSOCIATED GATES TO REMAIN, PROTECT IN PLACE
 - N.05 EXISTING UNDERGROUND COMMUNICATIONS VAULT TO REMAIN, PROTECT IN PLACE

SITE SIGNAGE SCHEDULE

TYPE	DESCRIPTION	SPEC	DETAIL
VS-1	ACCESSIBLE PARKING SITE ENTRANCE	10440	12/A1.3.1
VS-2	VAN ACCESSIBLE PARKING SPACE	10440	7/A1.3.1
VS-3	VEHICLE STOP SIGN	10440	17/A1.3.1
VS-4	NO PEDESTRIAN & VEHICLE CROSSING SIGN	10440	16/A1.3.1
VS-5	AUTHORIZED VEHICLES ONLY SIGN	10440	13/A1.3.1
DS-1	ACCESSIBLE DIRECTIONAL SIGN	10440	15/A1.3.1

NOTES

- SEE NOTES ON SHEET G0.3.1 FOR MORE ACCESSIBILITY INFORMATION.

LEGEND

- CHAINLINK FENCE & GATE SEE DET. 7/A1.3.3
- ACCESSIBLE PATH OF TRAVEL 4'-0" WIDE MIN. CONCRETE OR A.C. PAVED. SEE CIVIL DRAWINGS FOR ADDITIONAL INFORMATION ON MATERIAL, SLOPES AND ELEVATIONS. SEE NOTES ABOVE.
- ASSUMED PROPERTY LINE
- CONTROL JOINTS, SEE DETAIL 6A/A1.3.2
- EXPANSION JOINTS, SEE DETAIL 6B/A1.3.2
- NOTE: TYP. SITE WORK CONCRETE EXPANSION & CONTROL JOINTS TO BE 5'-0" MAX OC
- VS-1 MOUNTED SIGNAGE
- VS-1 POLL MOUNTED SIGNAGE
- M MEN'S RESTROOM LOCATION
- W WOMEN'S RESTROOM LOCATION
- U UNISEX RESTROOM LOCATION
- DF DRINKING FOUNTAIN LOCATION
- LANDSCAPING, PER LANDSCAPE DRAWINGS
- DETECTABLE WARNING TILE, SEE DETAIL 11/A1.3.1
- CONCRETE SITE WORK, PER CIVIL DRAWINGS
- FABRICATED STL. FENCE TYPE A, SEE SPECS. 32 31 17
- FABRICATED STL. FENCE & GATE TYPE B, SEE DETAILS 1-5/A1.3.3 AND SPECS. 32 31 17

LITTLE
DIVERSIFIED ARCHITECTURAL CONSULTING

1300 Dove Street, Suite 100
Newport Beach, CA 92660
T: 949.698.1400 F: 949.698.1433
www.littleonline.com

This drawing and the design shown are the property of Little Diversified Architectural Consulting. The reproduction, copying or other use of this drawing without their written consent is prohibited and any infringement will be subject to legal action.

© Little 2016

COMPTON CCD

CAMPUS PUBLIC SAFETY BUILDING

1111 EAST ARTESIA BOULEVARD,
COMPTON CALIFORNIA 90221

IDENTIFICATION STAMP
DIV. OF THE STATE ARCHITECT
OFFICE OF REGULATION SERVICES
FILE NO: 19-C1
AR: 03-117673
DATE: DEC. 12 2017

NOTES

NO REASON DATE

LICENSED ARCHITECT
RITA S. CARTER
NO. C35431
REL. 4-30-19

SITE PLAN

913-4675-00

12/01/16 A1.1.1

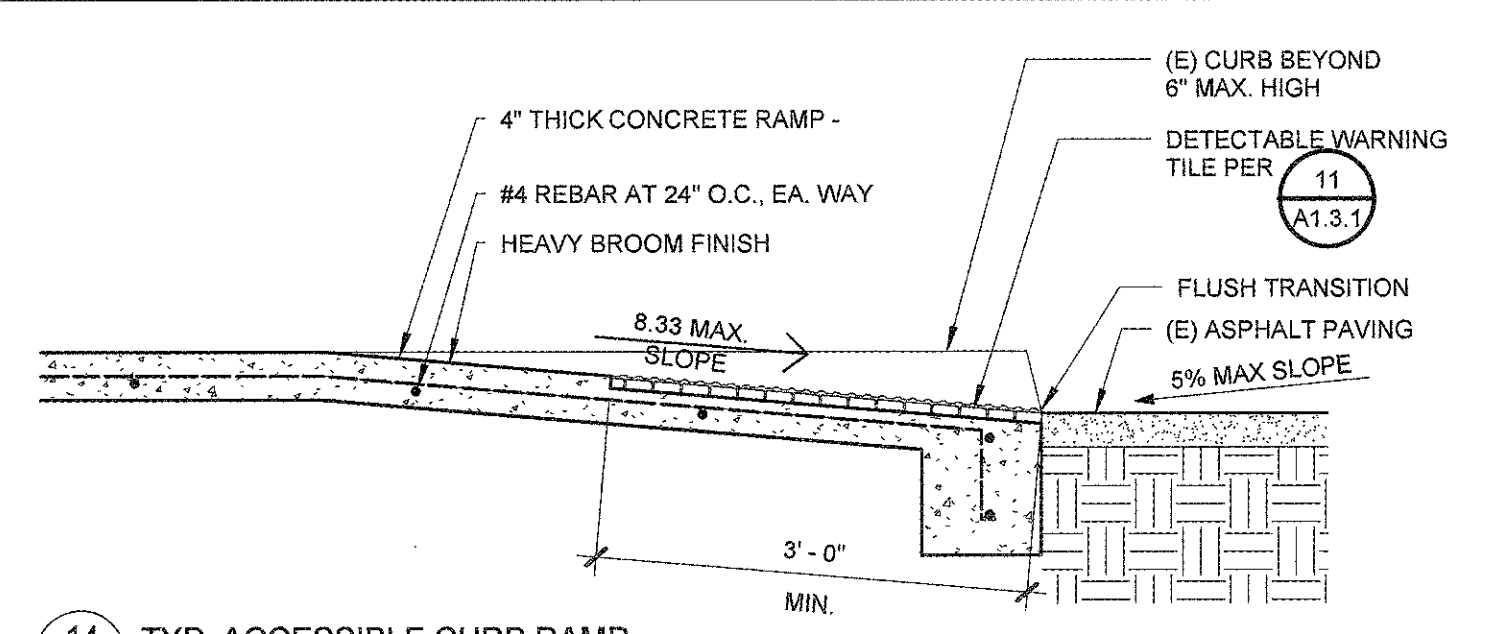

14 TYP. ACCESSIBLE CURB RAMP
A1.3.1 3/4" = 1'-0"

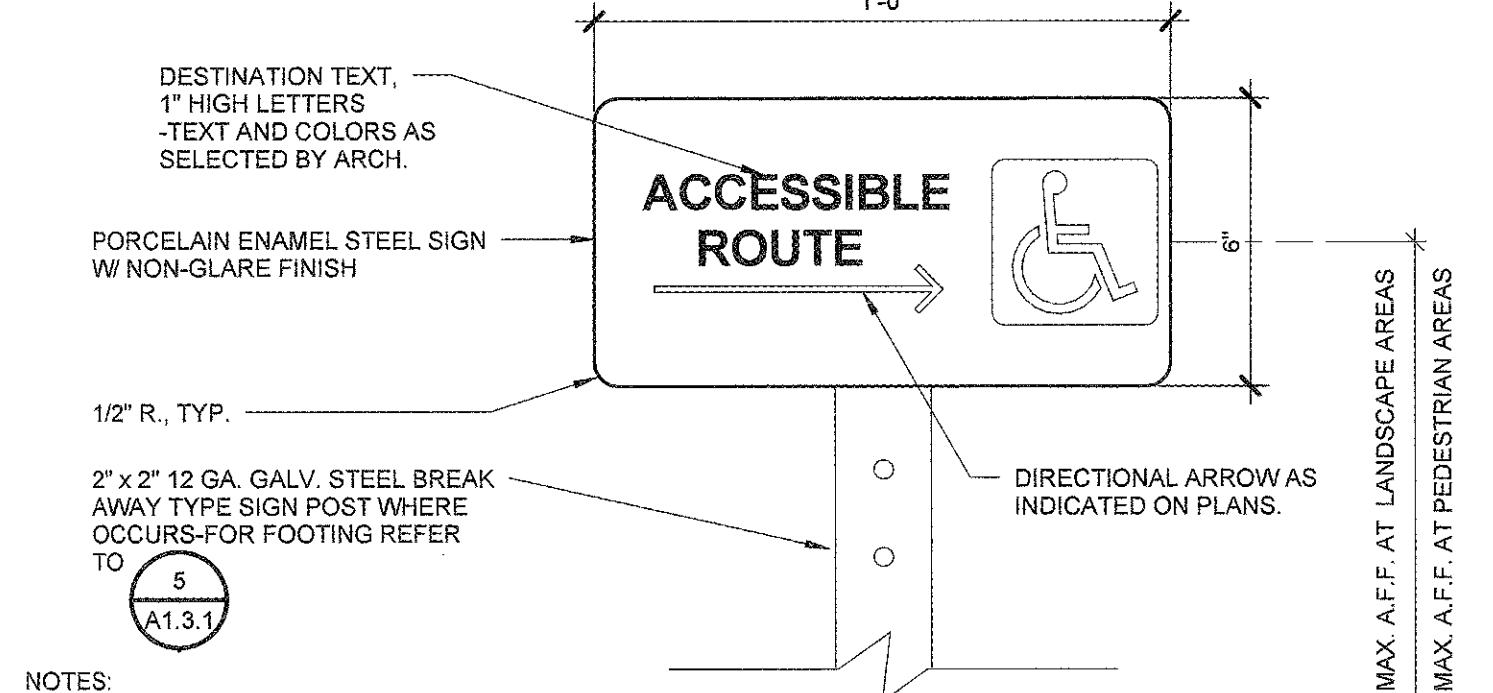

NOTES:
1. LOCATE SIGNS PER PLANS.
2. PROVIDE MECHANICAL MOUNTING W/ VANDAL RESISTANT FASTENERS. COMPLY W/ TITLE 24 AND THE AMERICANS WITH DISABILITIES ACT (A.D.A.) REQUIREMENTS.
3. ARROW CONFIGURATION
4. LETTERS AND NUMBERS ON SIGNS SHALL HAVE A WIDTH OF THE UPPERCASE LETTER "O" IS 60% MIN. & 110% MAX. OF THE HEIGHT OF THE UPPERCASE LETTER "T". STROKE THICKNESS OF THE UPPERCASE LETTER "T" SHALL BE 10% MIN. & 20% MAX. OF THE HEIGHT OF THE CHARACTER. (CBC 11B-703.5.5)
5. CHARACTERS AND SYMBOLS SHALL CONTRAST WITH THEIR BACKGROUND PER CBC 11B-703.5.1 (70% MIN.)
6. LETTERS, NUMBERS AND GRAPHICS ON SIGNS SHALL BE SANS-SERIF UPPERCASE CHARACTERS.

DS-1

15 ACCESSIBLE DIRECTIONAL SIGN
A1.3.1 3" = 1'-0"

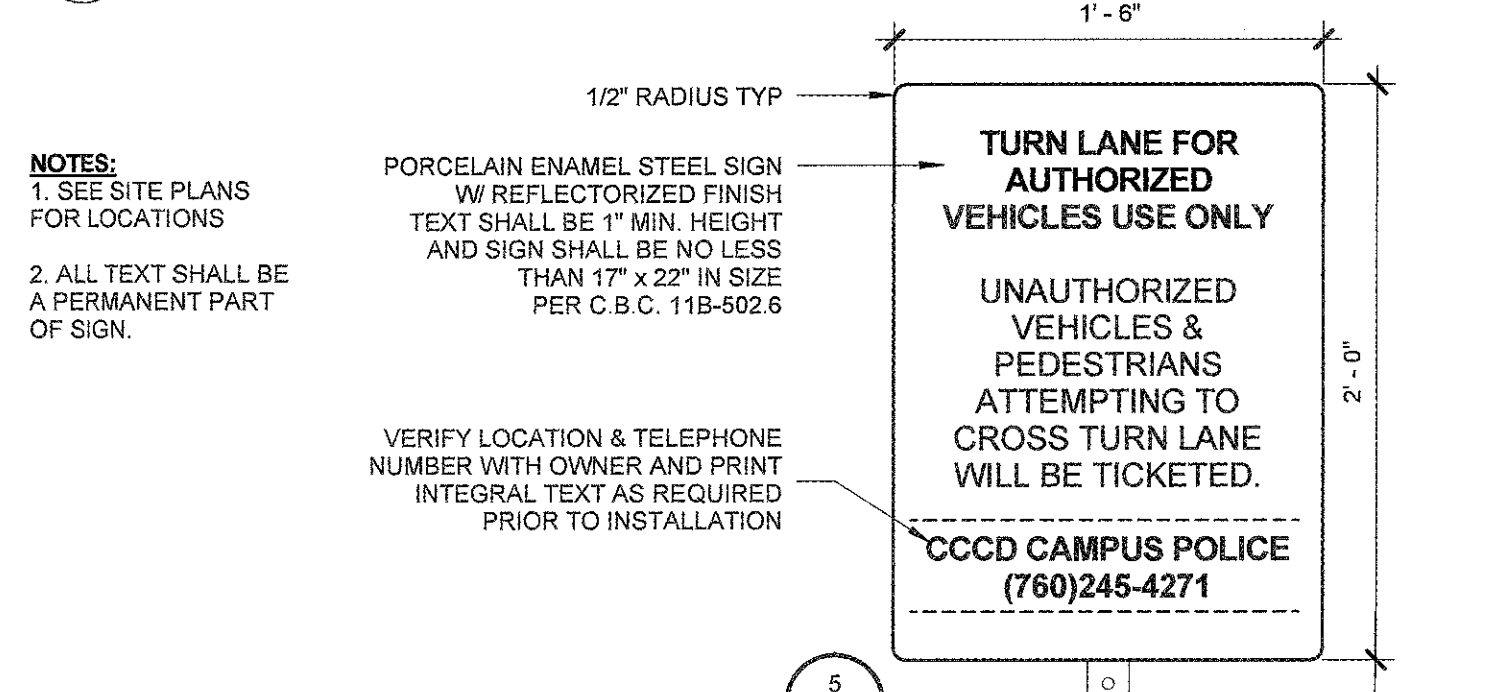

NOTES:
1. LOCATE SIGNS PER PLANS.
2. PROVIDE MECHANICAL MOUNTING W/ VANDAL RESISTANT FASTENERS. COMPLY W/ TITLE 24 AND THE AMERICANS WITH DISABILITIES ACT (A.D.A.) REQUIREMENTS.
3. LETTERS AND NUMBERS ON SIGNS SHALL HAVE A WIDTH OF THE UPPERCASE LETTER "O" IS 60% MIN. & 110% MAX. OF THE HEIGHT OF THE UPPERCASE LETTER "T". STROKE THICKNESS OF THE UPPERCASE LETTER "T" SHALL BE 10% MIN. & 20% MAX. OF THE HEIGHT OF THE CHARACTER. (CBC 11B-703.5.5)
4. CHARACTERS AND SYMBOLS SHALL CONTRAST WITH THEIR BACKGROUND PER CBC 11B-703.5.1 (70% MIN.)
5. LETTERS, NUMBERS AND GRAPHICS ON SIGNS SHALL BE SANS-SERIF UPPERCASE CHARACTERS.

VS-4

16 NO PEDESTRIAN & VEHICLE CROSSING SIGN
A1.3.1 1 1/2" = 1'-0"

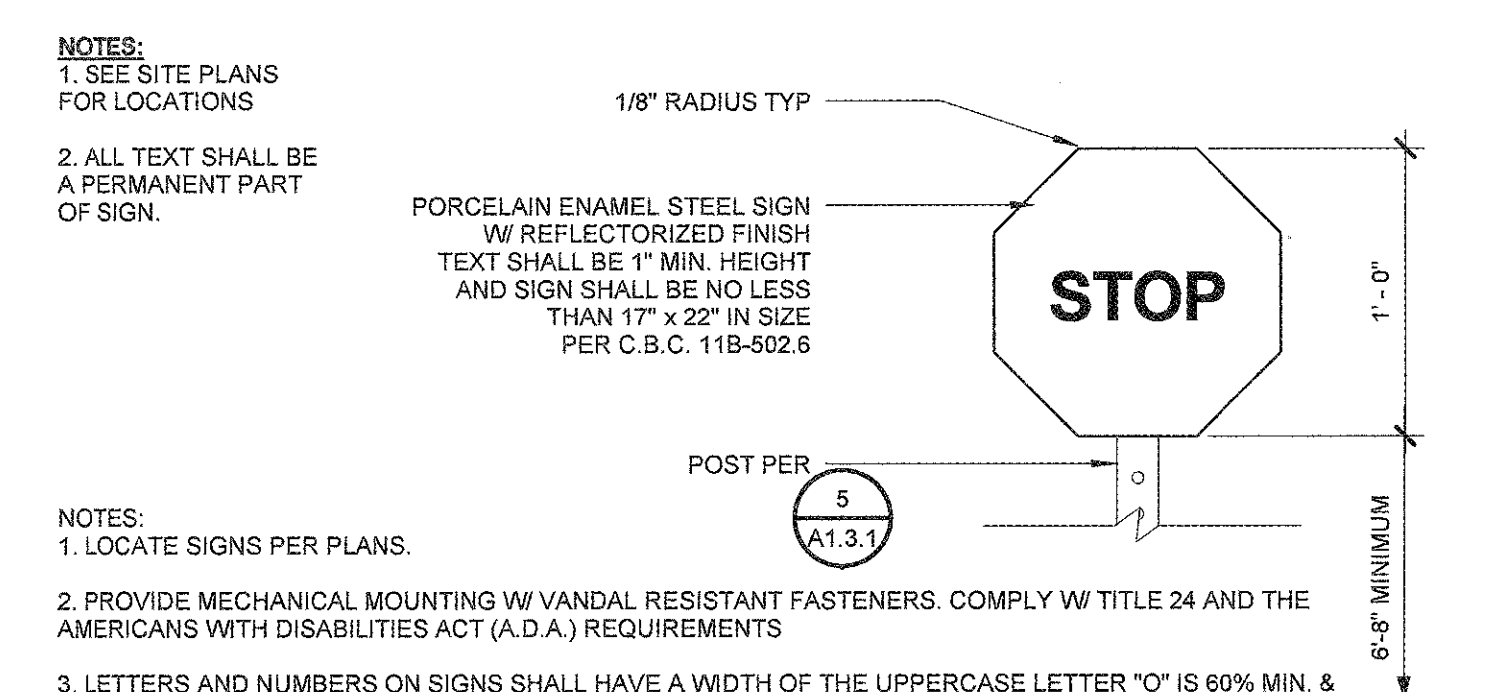

17 STOP SIGN
A1.3.1 1 1/2" = 1'-0"

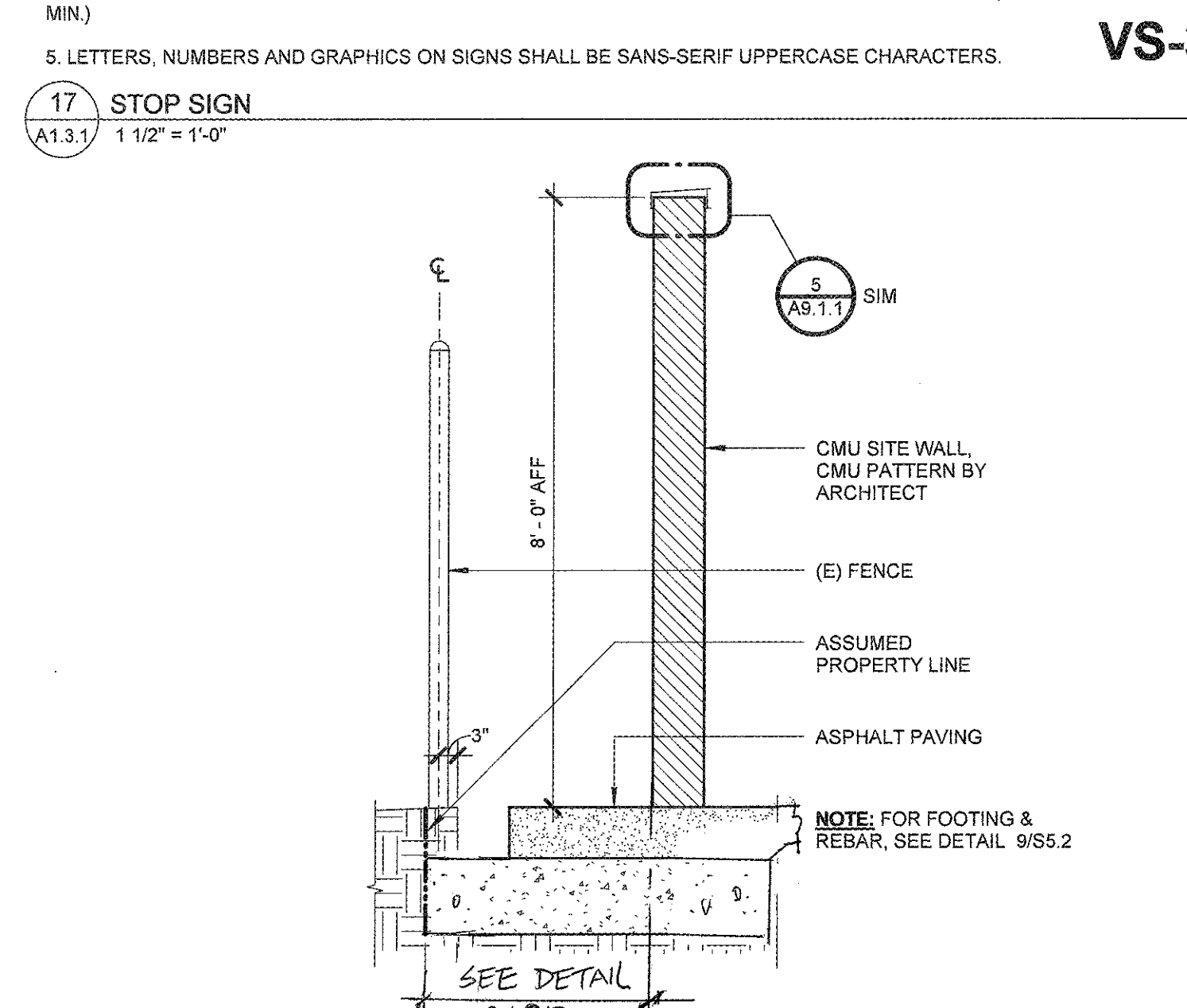

18 CMU SITE WALL
A1.3.1 N.T.S.

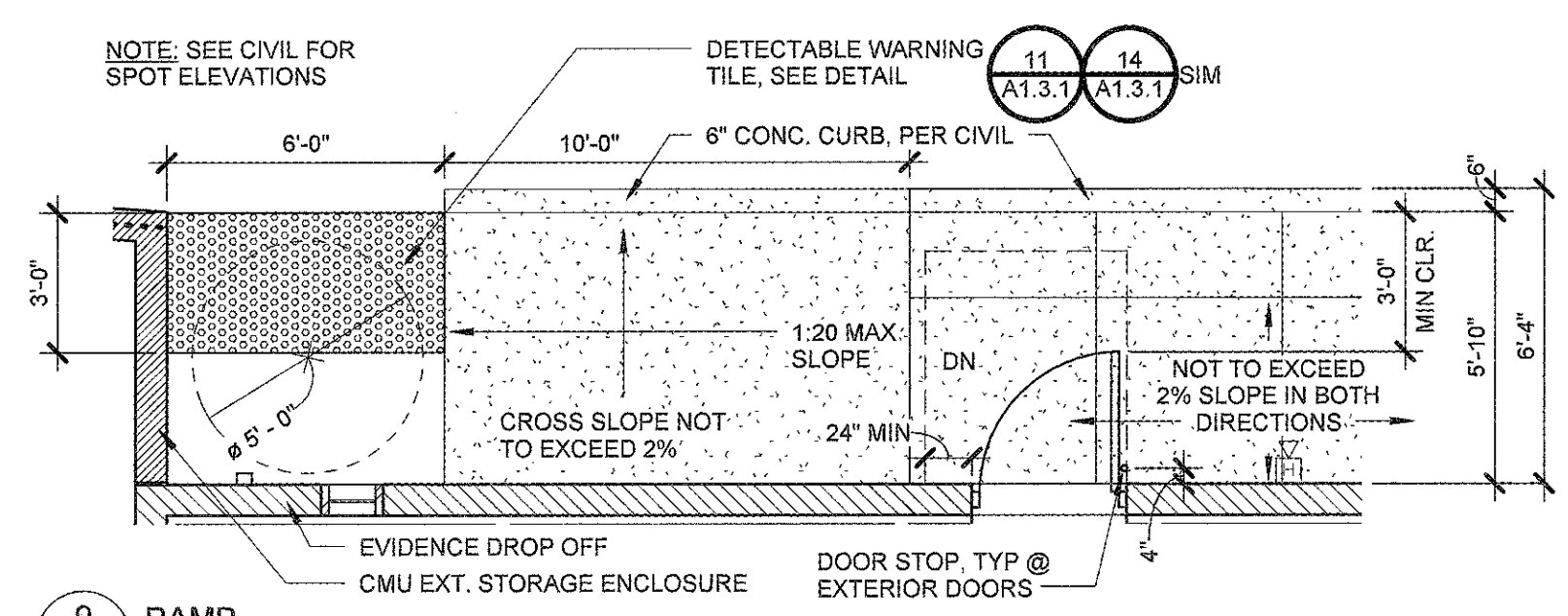

9 RAMP
A1.3.1 1/4" = 1'-0"

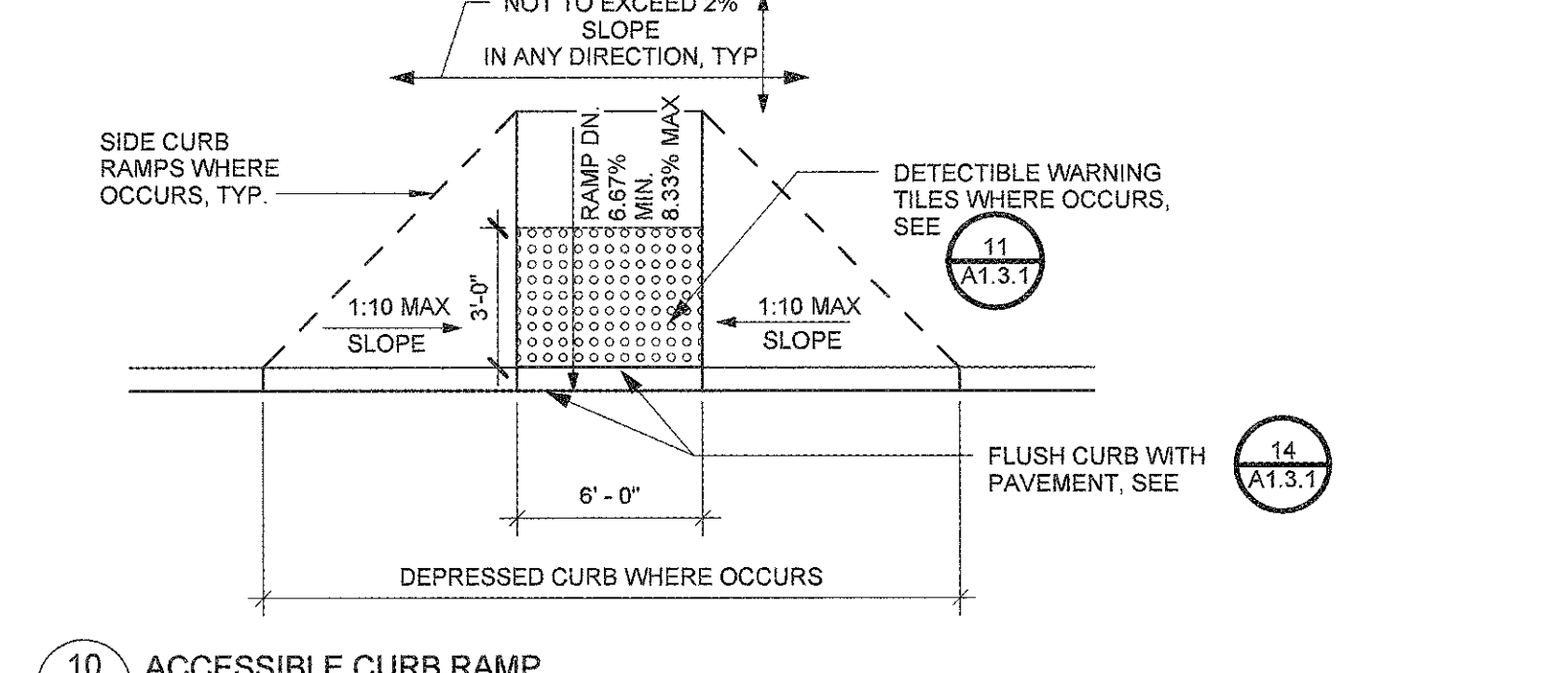

10 ACCESSIBLE CURB RAMP
A1.3.1 1/4" = 1'-0"

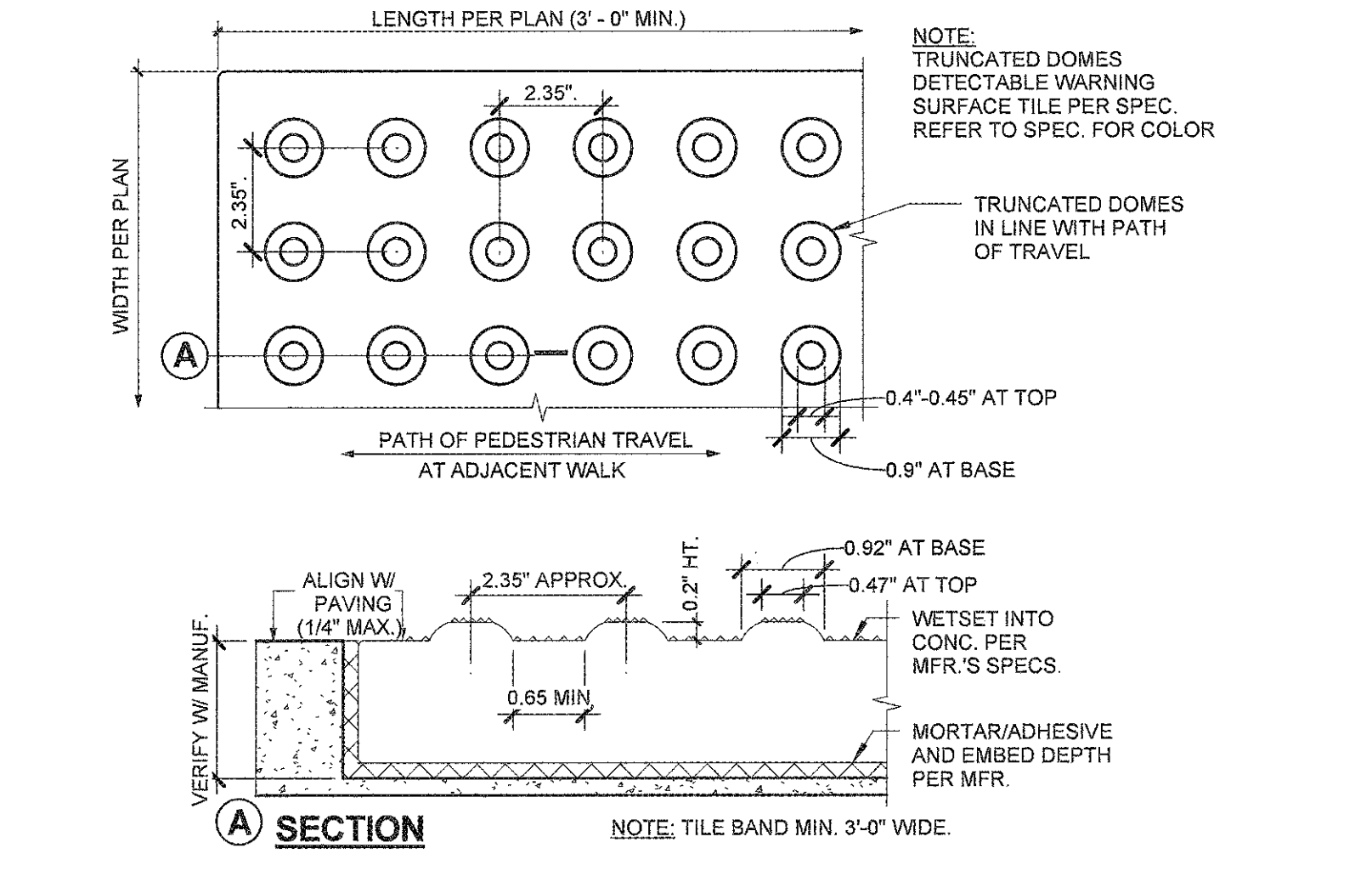

11 TYP. DETECTABLE WARNING SURFACE TILE
A1.3.1 3/4" = 1'-0"

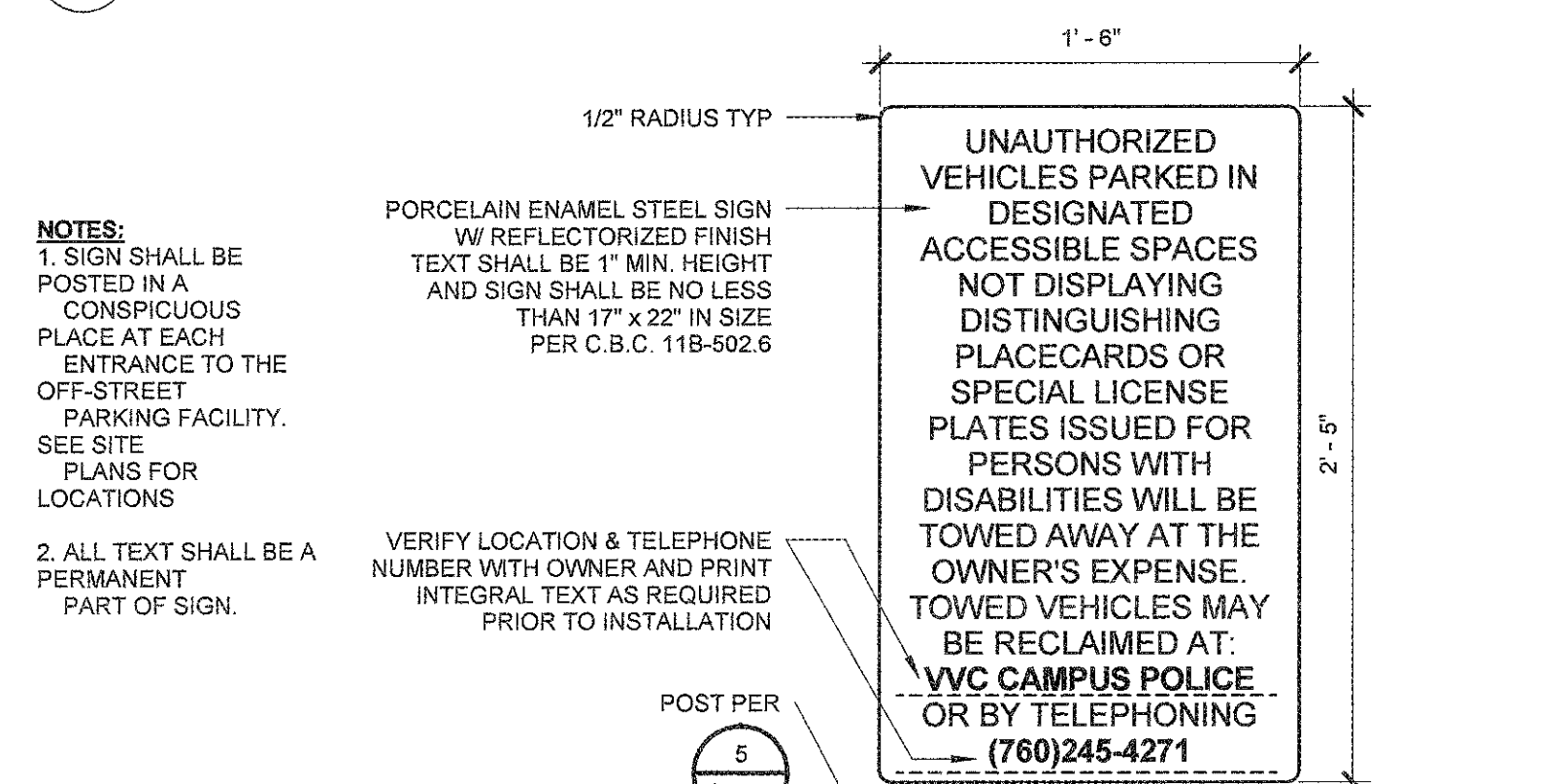

12 EXISTING ACCESSIBLE PARKING ENTRANCE SIGNAGE
A1.3.1 1 1/2" = 1'-0"

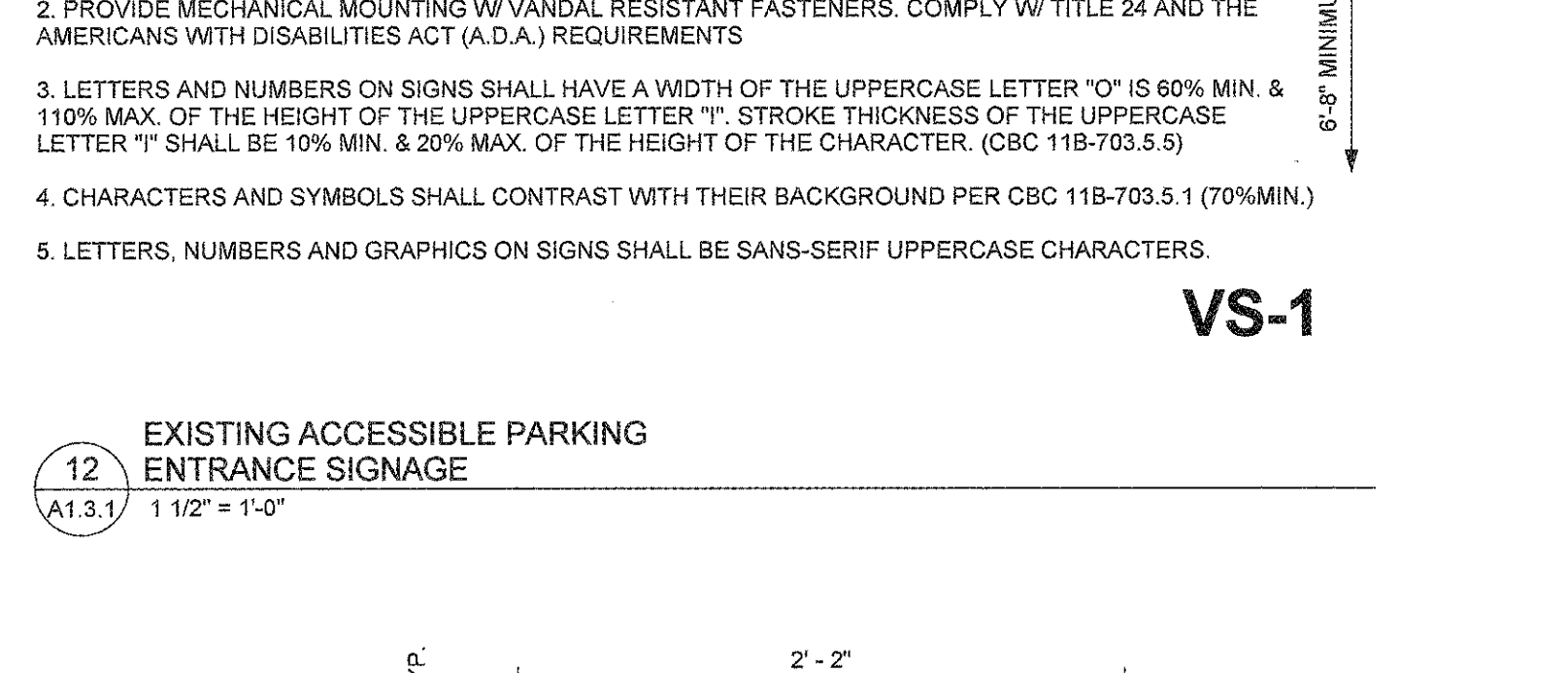

13 TYP. SERVICE VEHICLES ONLY SIGN
A1.3.1 1 1/2" = 1'-0"

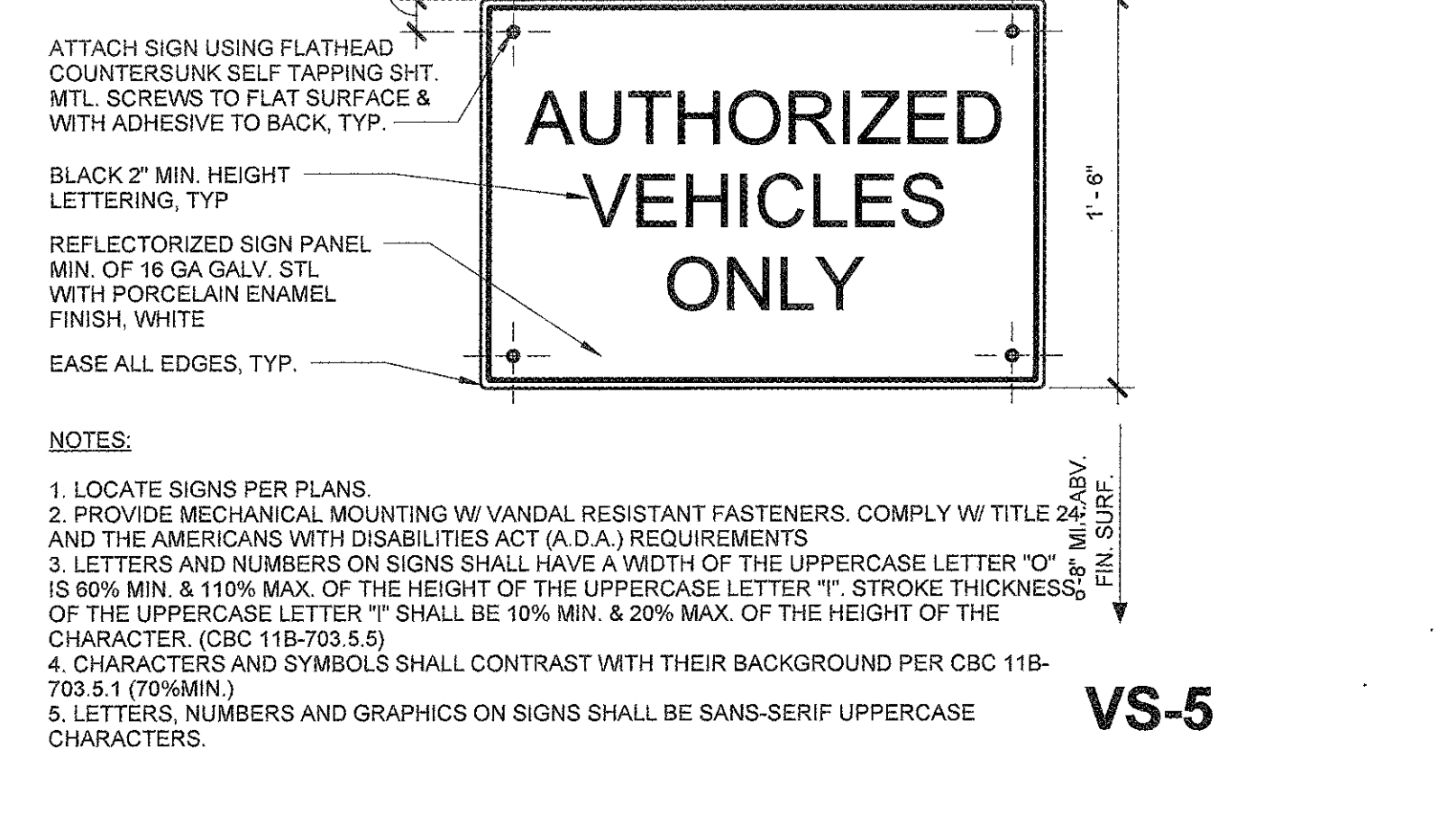

14 TYP. EXTERIOR PASSENGER LOADING ZONE SIGNAGE
A1.3.1 1 1/2" = 1'-0"

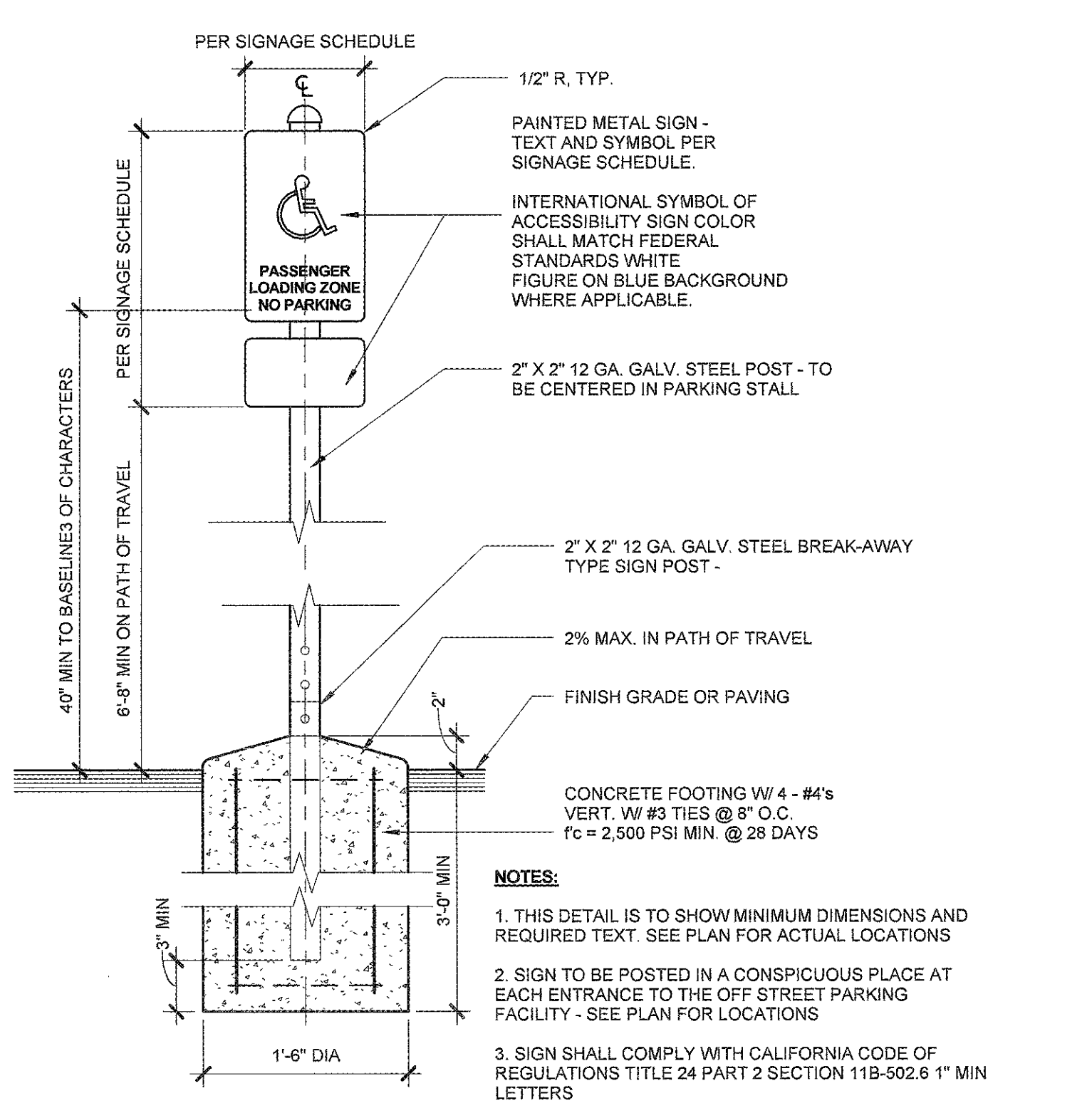

15 TYP. VAN ACCESSIBLE PARKING STALL SIGNAGE
A1.3.1 1 1/2" = 1'-0"

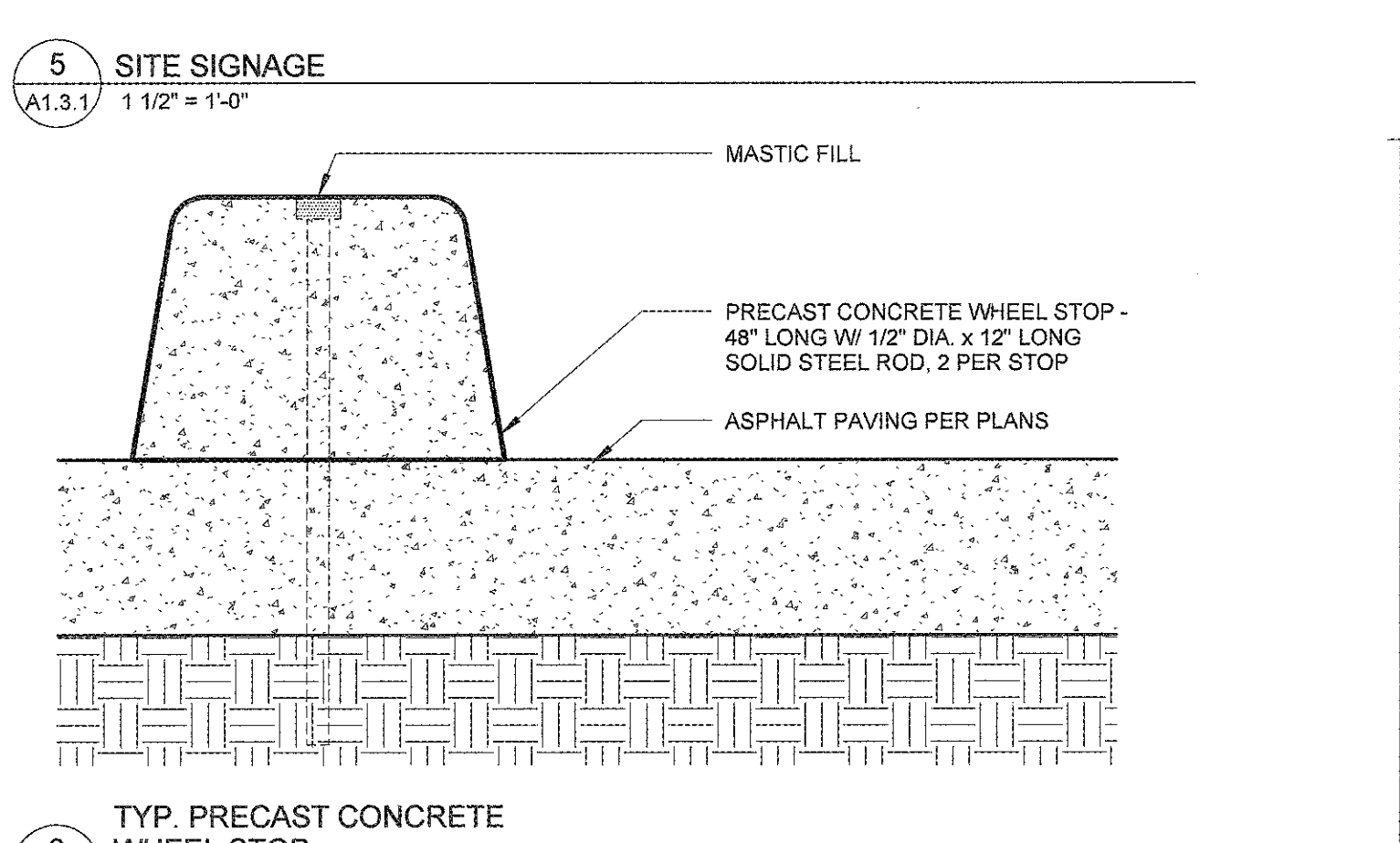

16 TYP. ACCESSIBLE PARKING ACCESS AISLE
A1.3.1 12" = 1'-0"

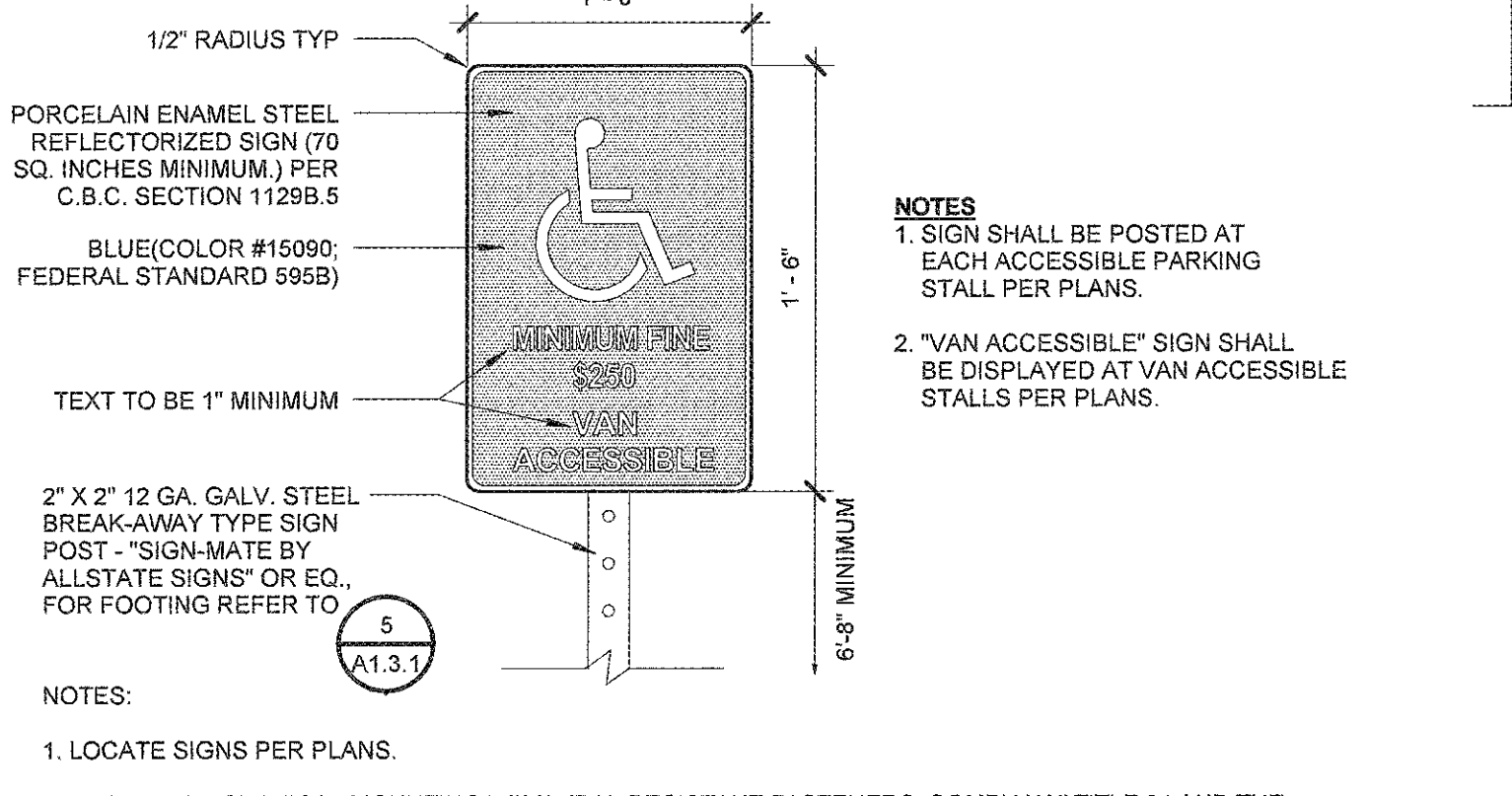

17 TYP. ACCESSIBLE PARKING STALL SYMBOL
A1.3.1 1" = 1'-0"

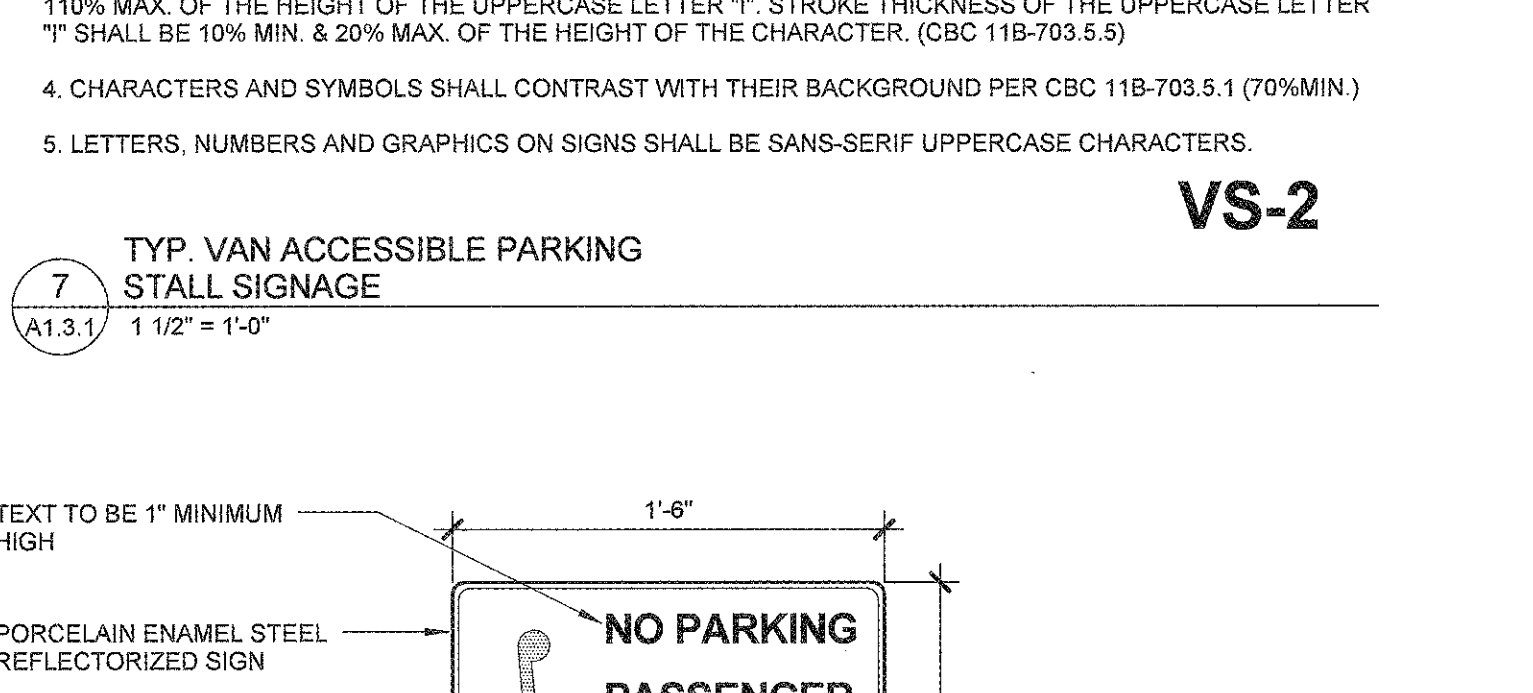

18 TYP. ACC. PEDESTRIAN P.O.T. CROSSWALK
A1.3.1 12" = 1'-0"

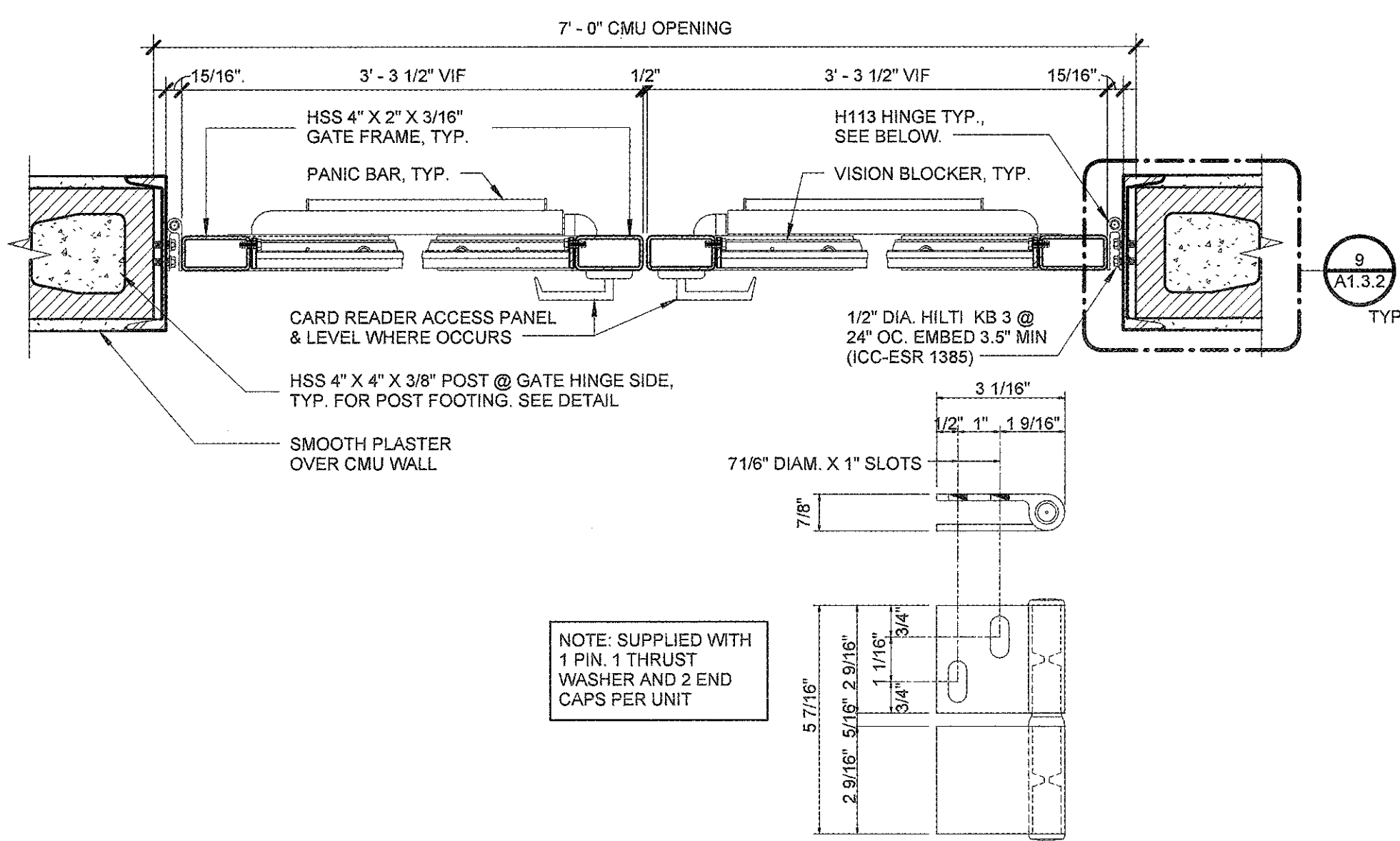

15 EXT. STORAGE GATE SECTION
A1.3.2 1 1/2\"/>

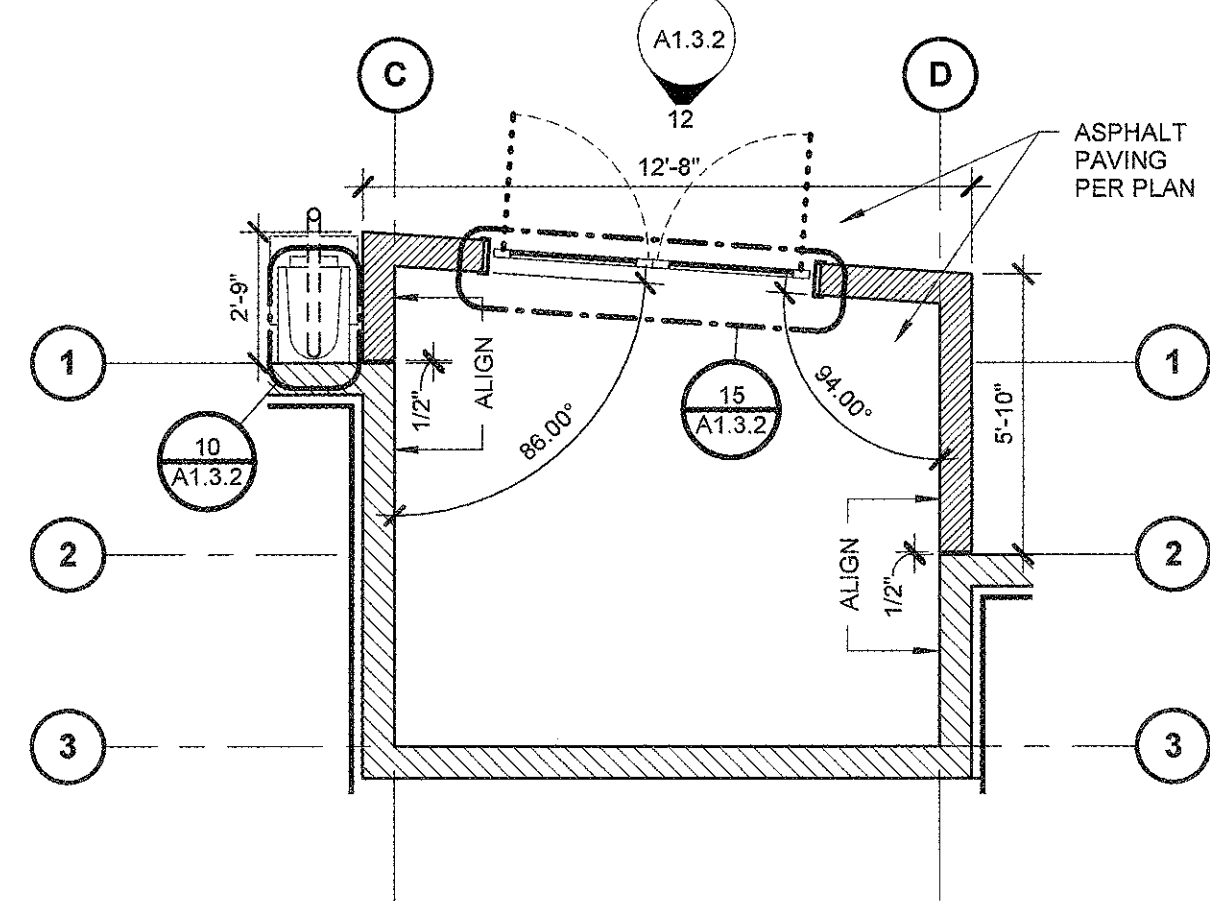

11 EXTERIOR STORAGE ENCLOSURE - PLAN
A1.3.2 1 1/2\"/>

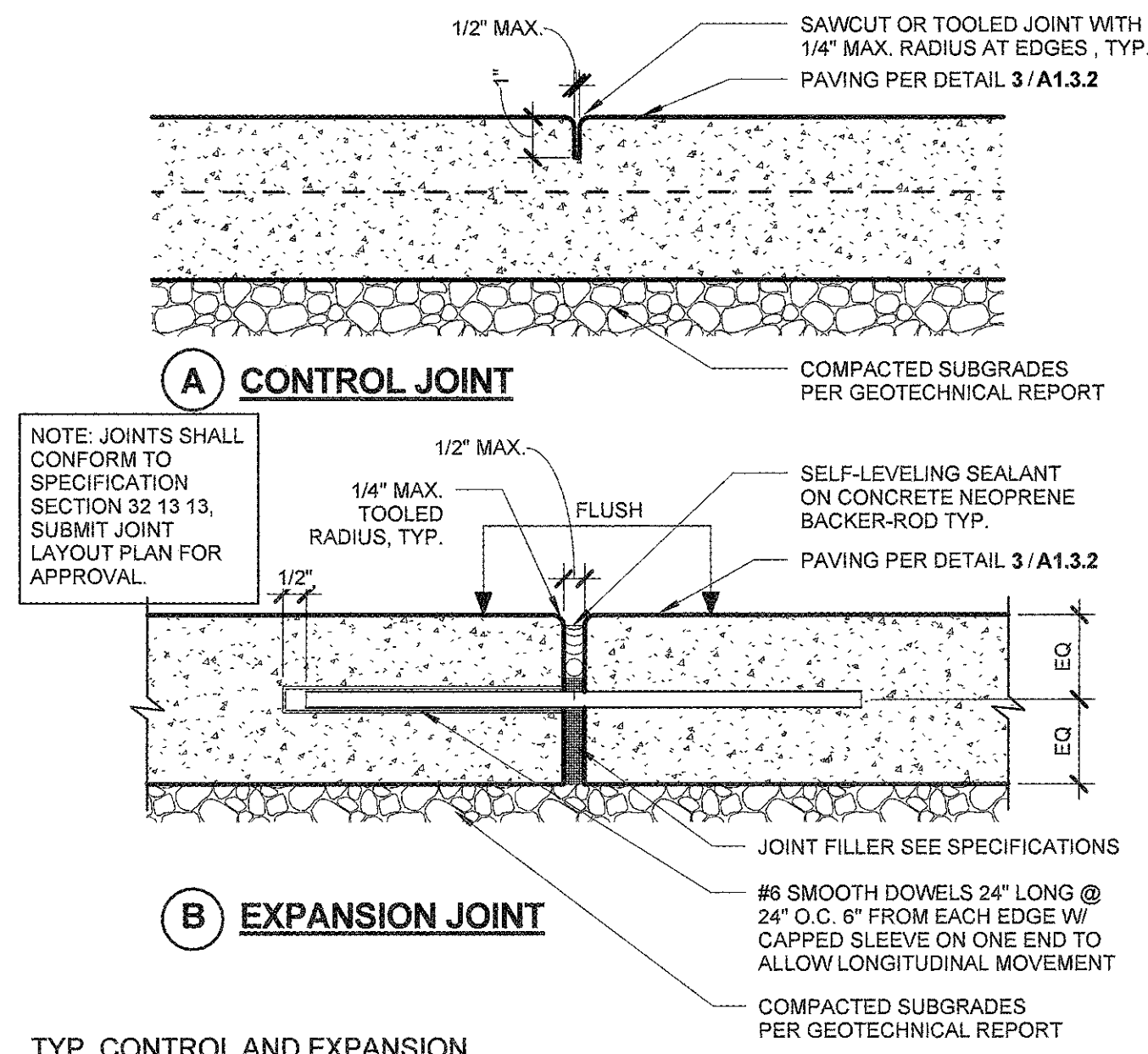

6 TYP. CONTROL AND EXPANSION JOINTS
A1.3.2 3\"/>

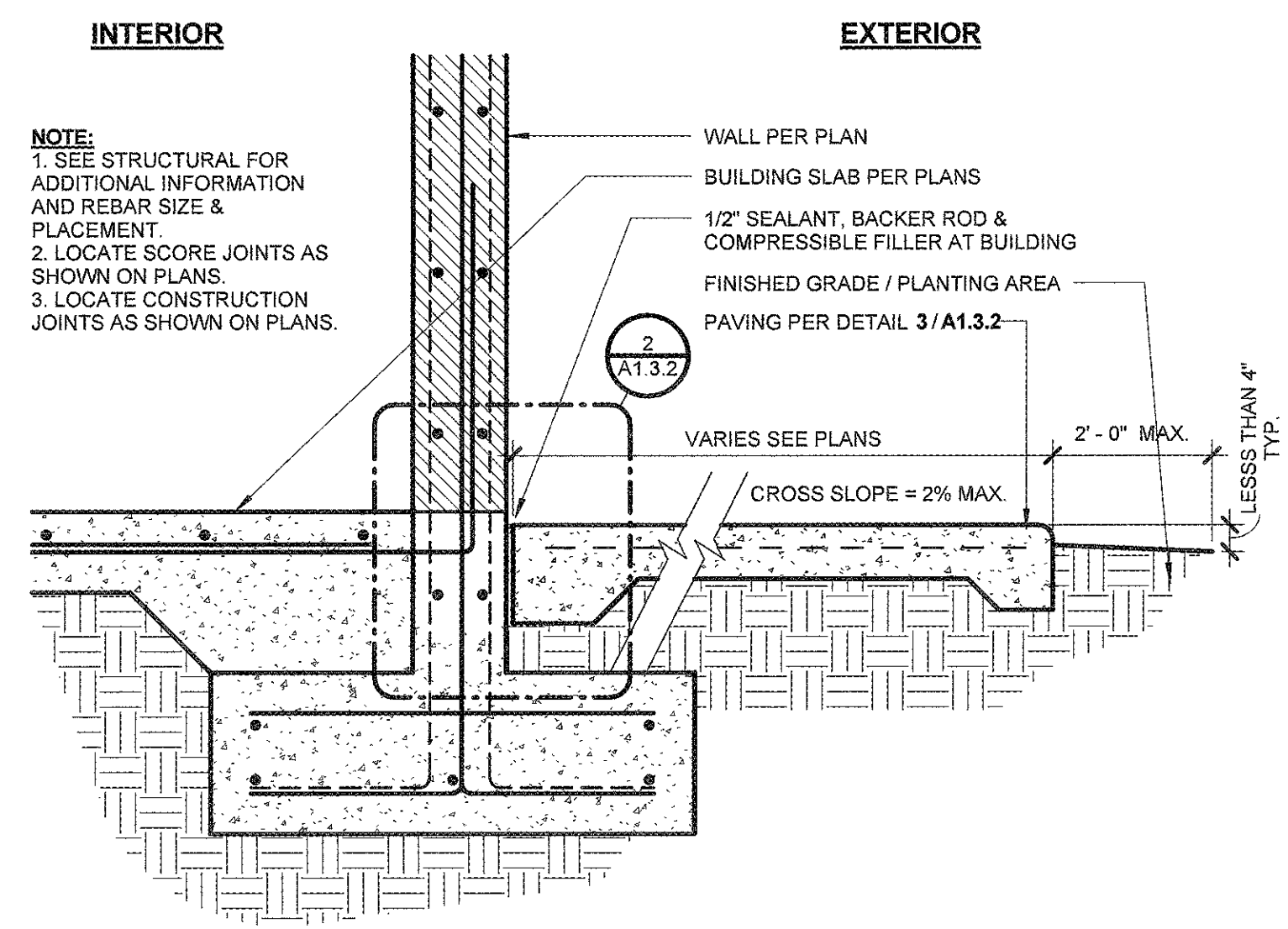

1 TYP. CONCRETE WALKWAY / MOW STRIP AT BUILDING
A1.3.2 1\"/>

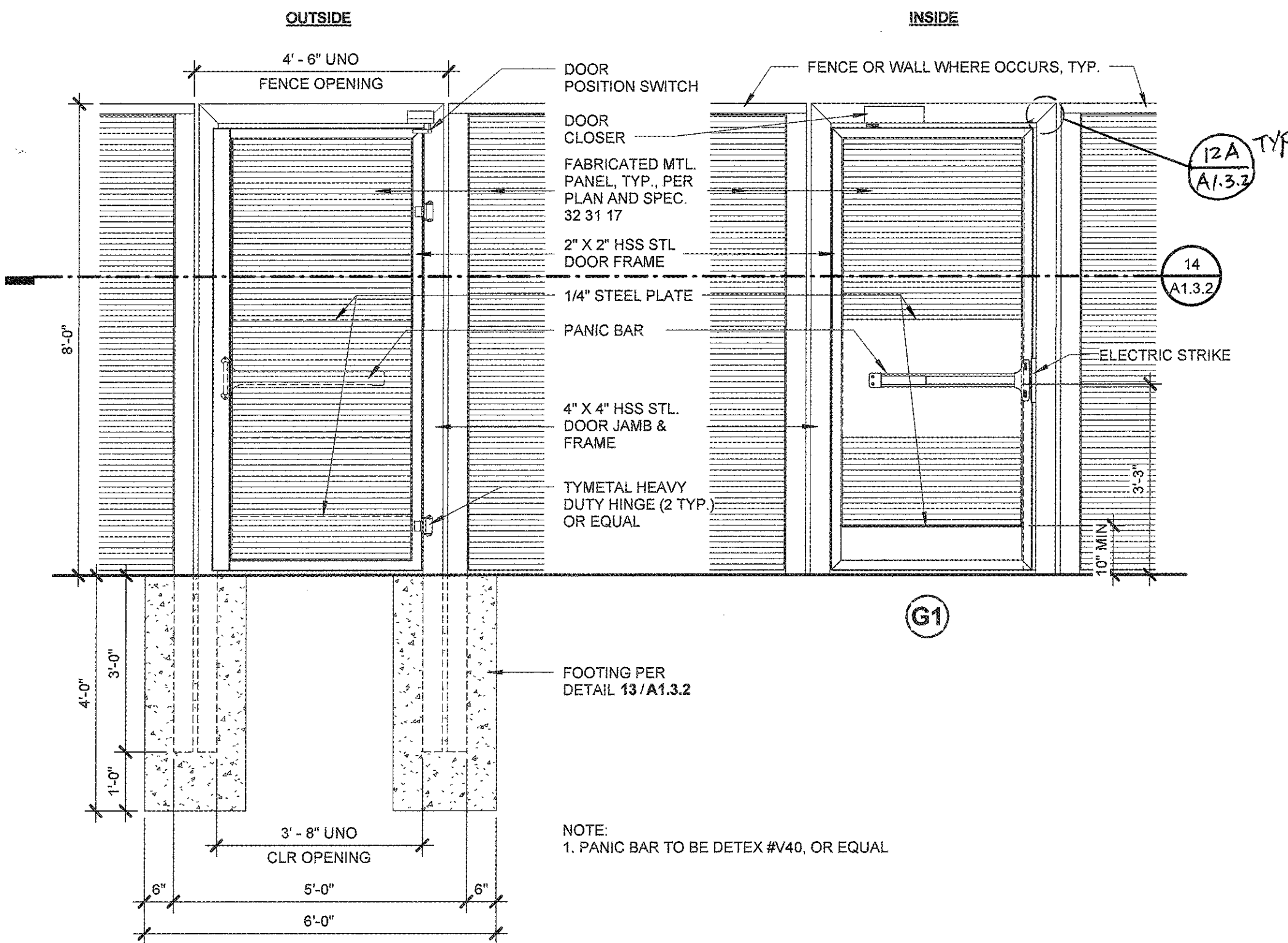

16 PANIC HARDWARE GATE
A1.3.2 1 1/2\"/>

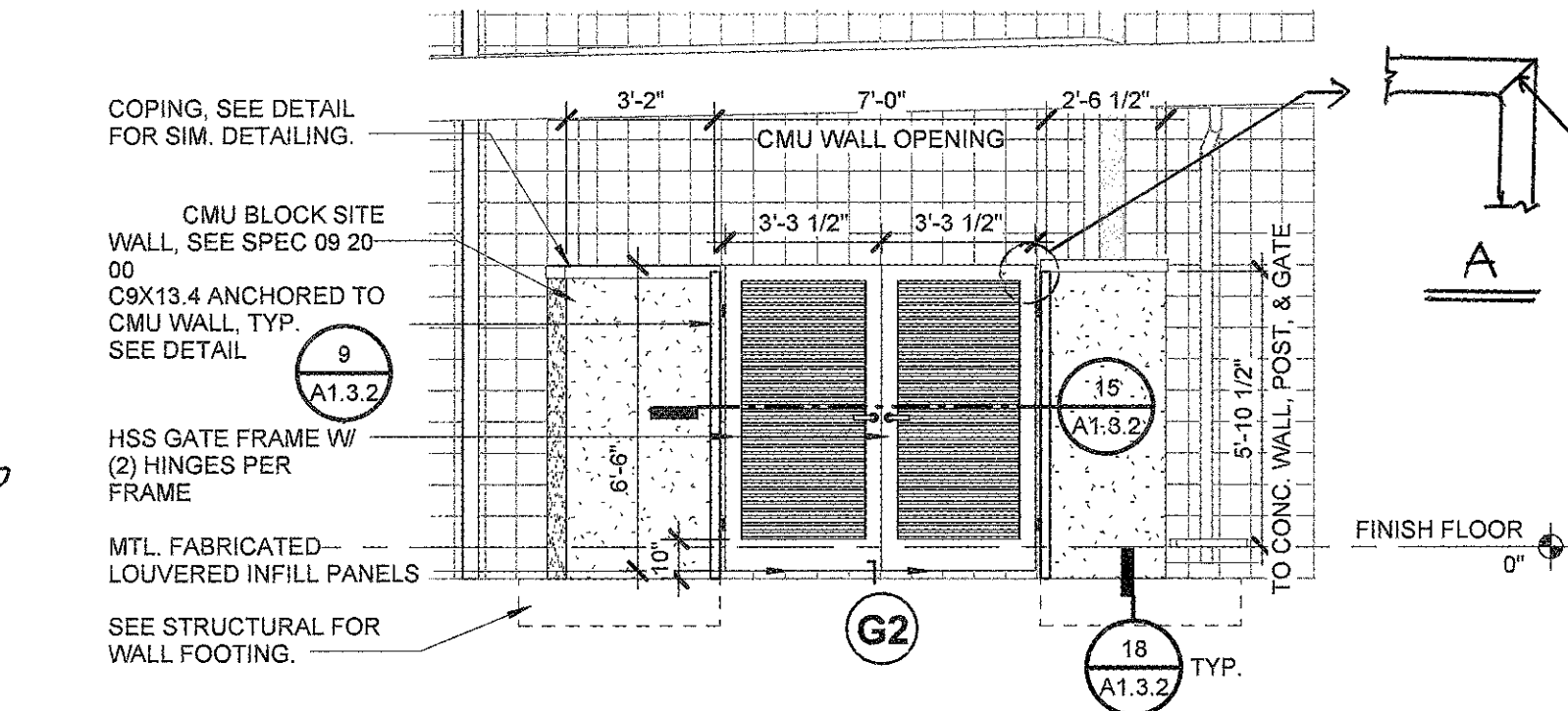

12 EXT. STORAGE ENCLOSURE N. ELEVATION
A1.3.2 1 1/2\"/>

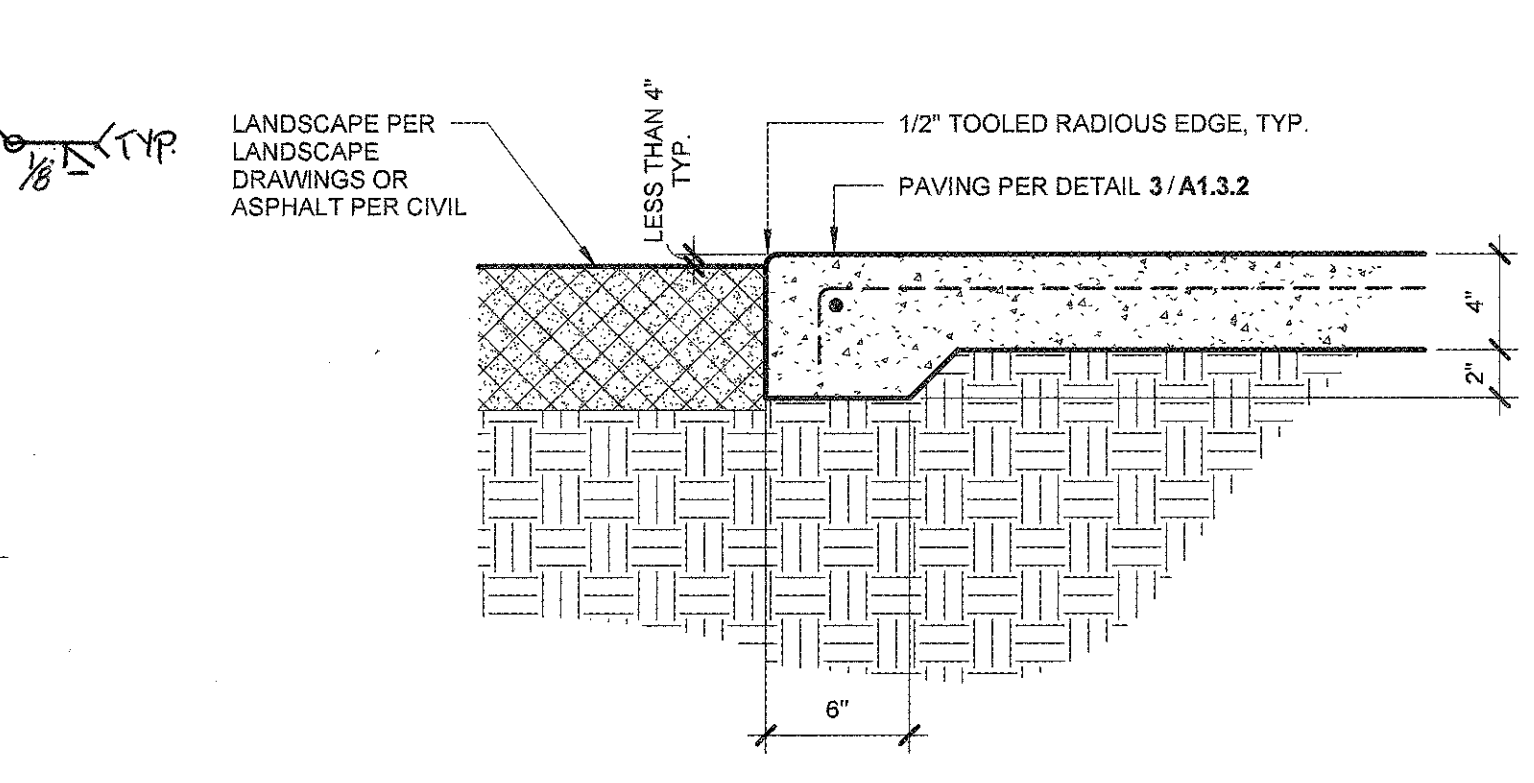

7 TYP. CONCRETE PAVING AT LANDSCAPE
A1.3.2 1 1/2\"/>

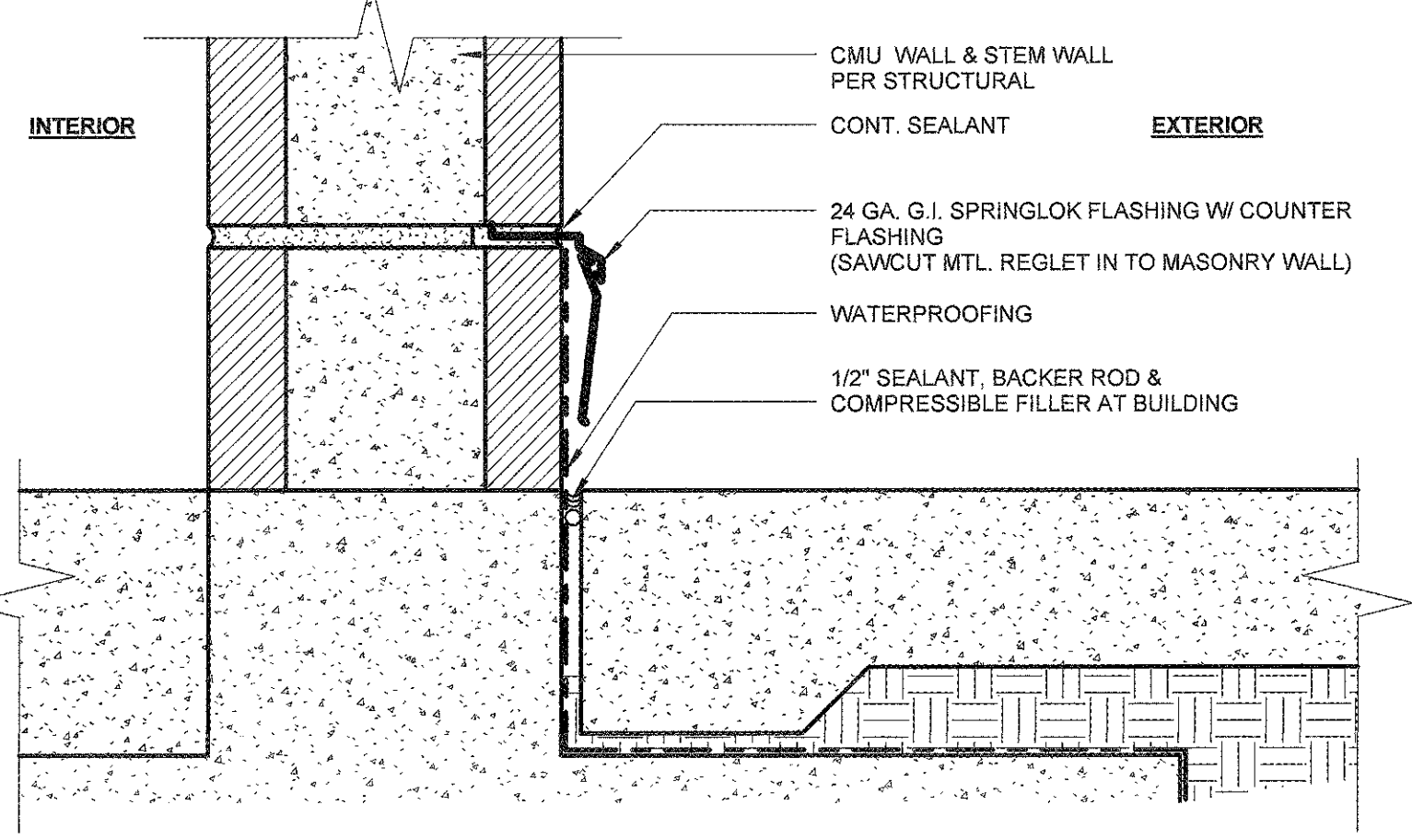

2 TYP. WATERPROOFING DETAIL
A1.3.2 3\"/>

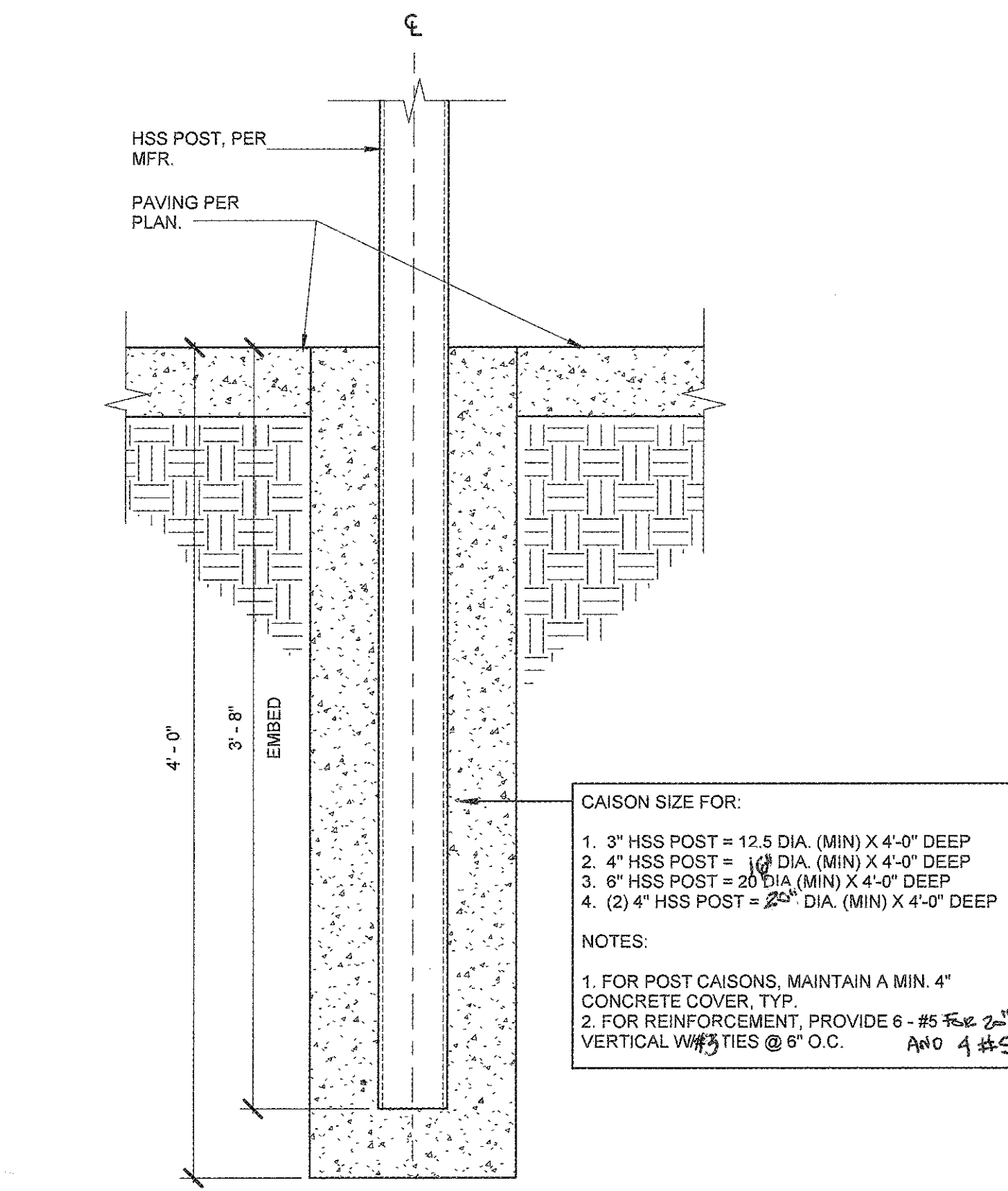

13 SITE POST FOOTING DETAIL
A1.3.2 1 1/2\"/>

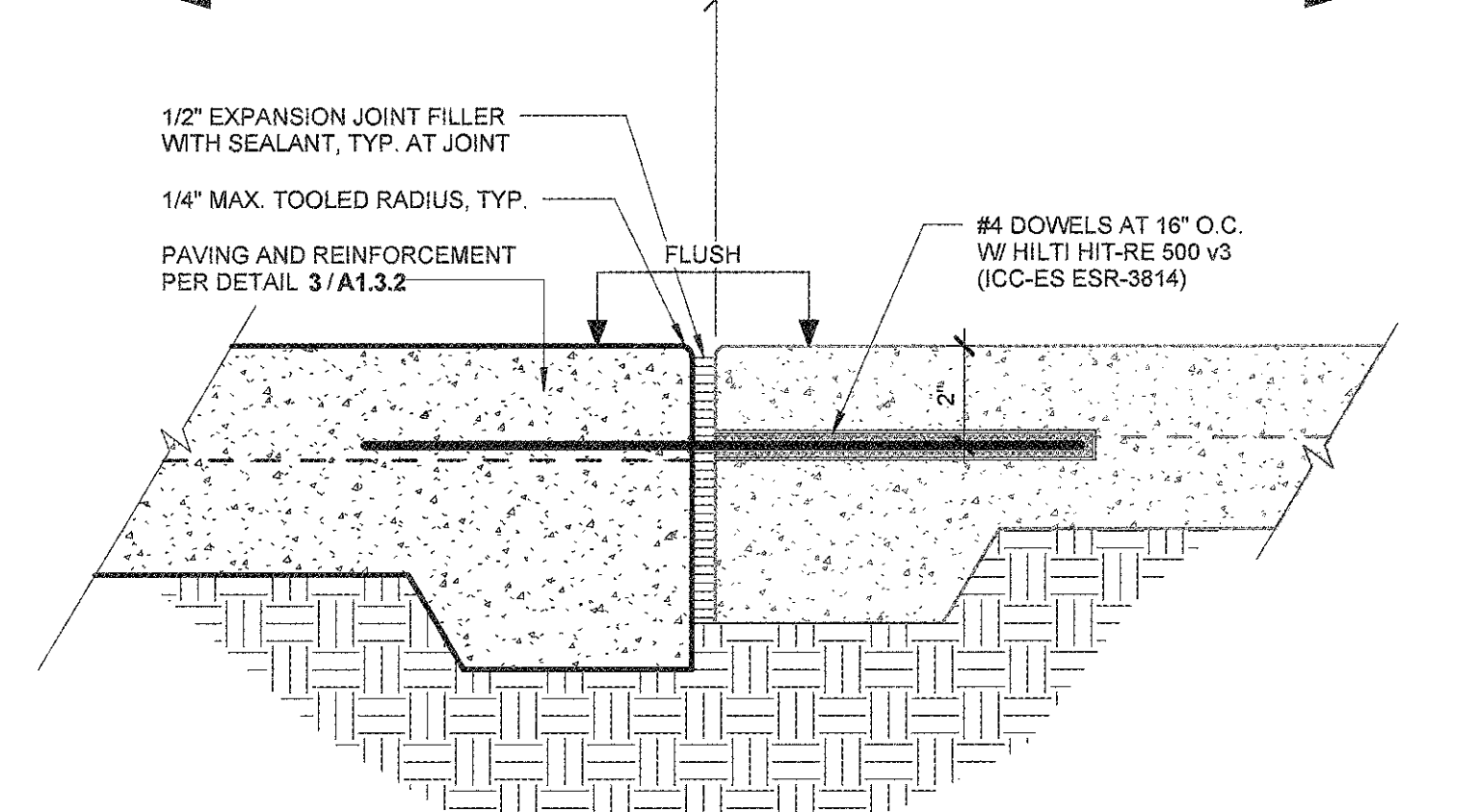

8 TYP. CONCRETE WALK TO EXISTING CONCRETE WALK
A1.3.2 3\"/>

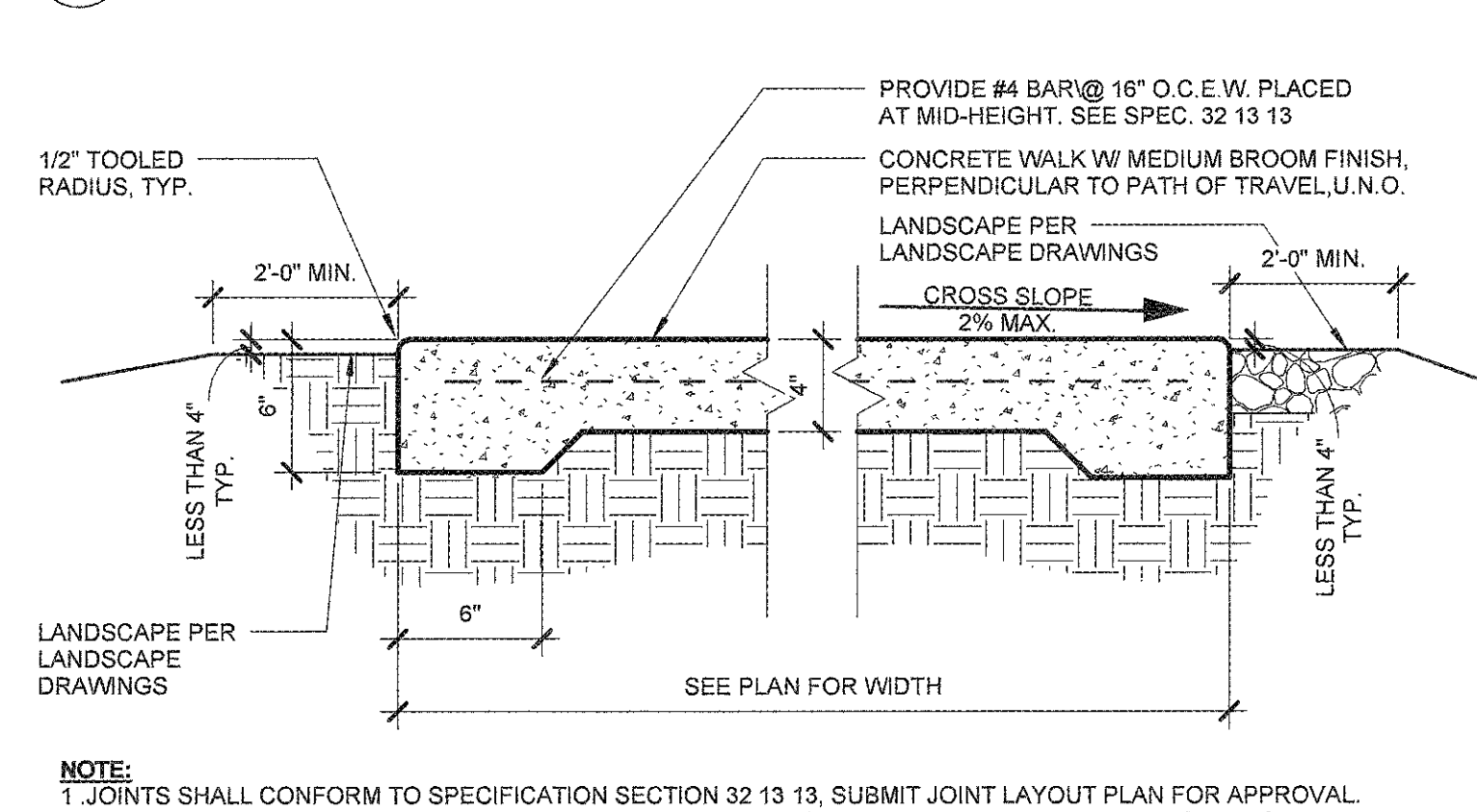

3 TYP. CONCRETE WALKWAY PAVING
A1.3.2 1 1/2\"/>

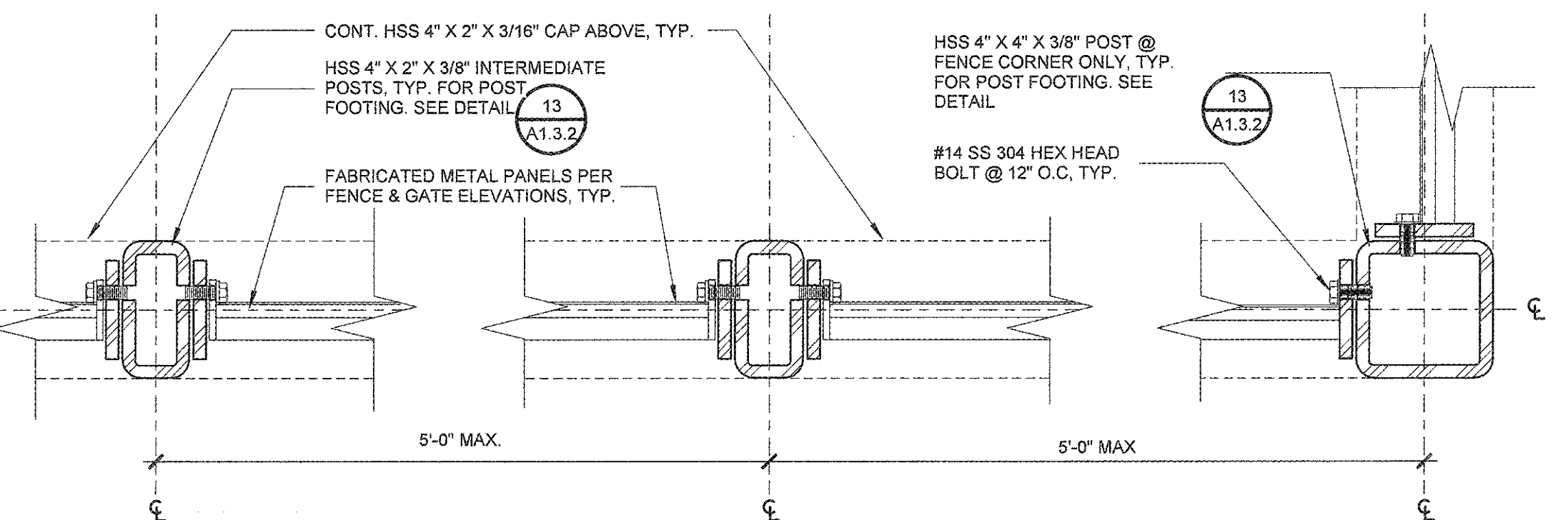

17 TYP. FENCE SECTION DET.
A1.3.2 3\"/>

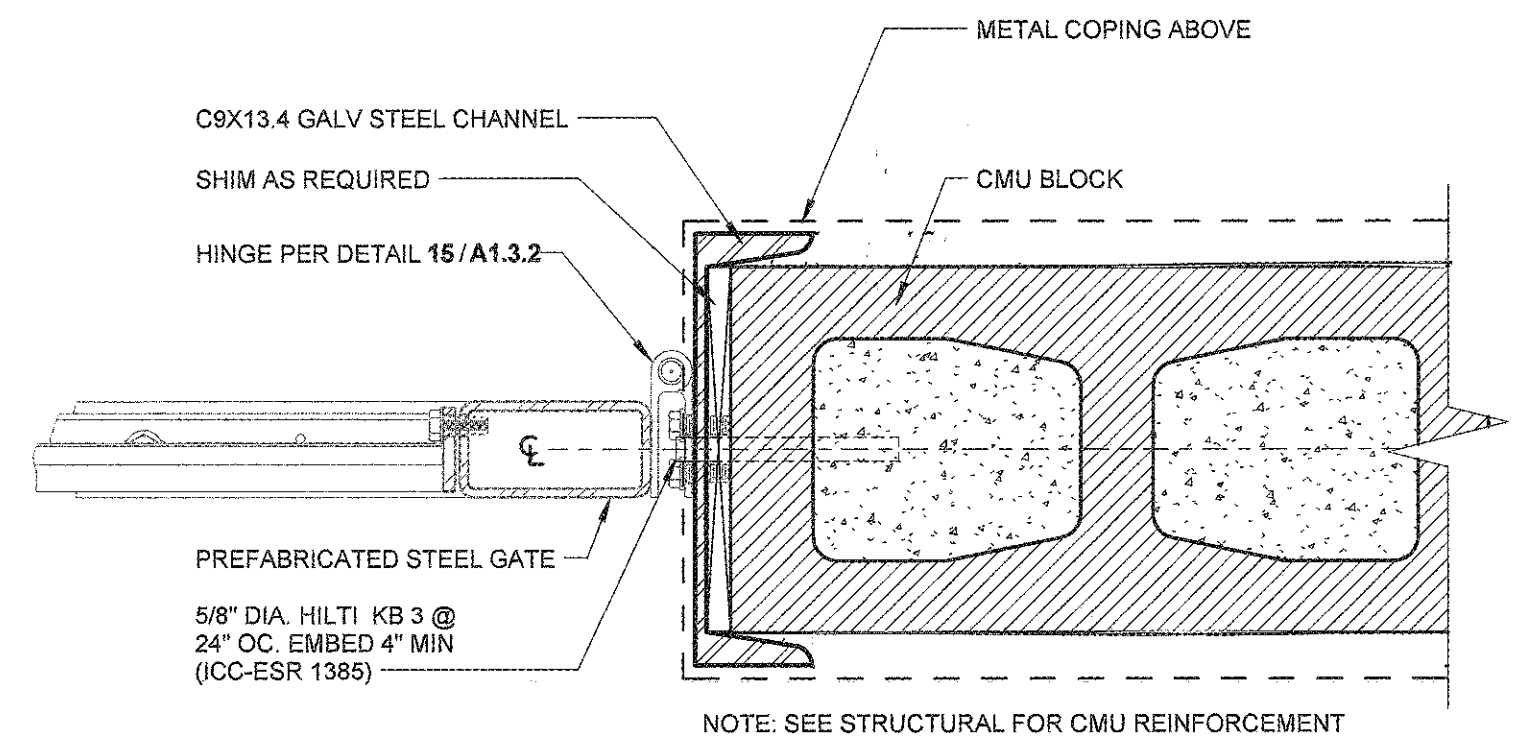

9 GATE HINGE DETAIL @ EXT. STORAGE ENCLOSURE
A1.3.2 3\"/>

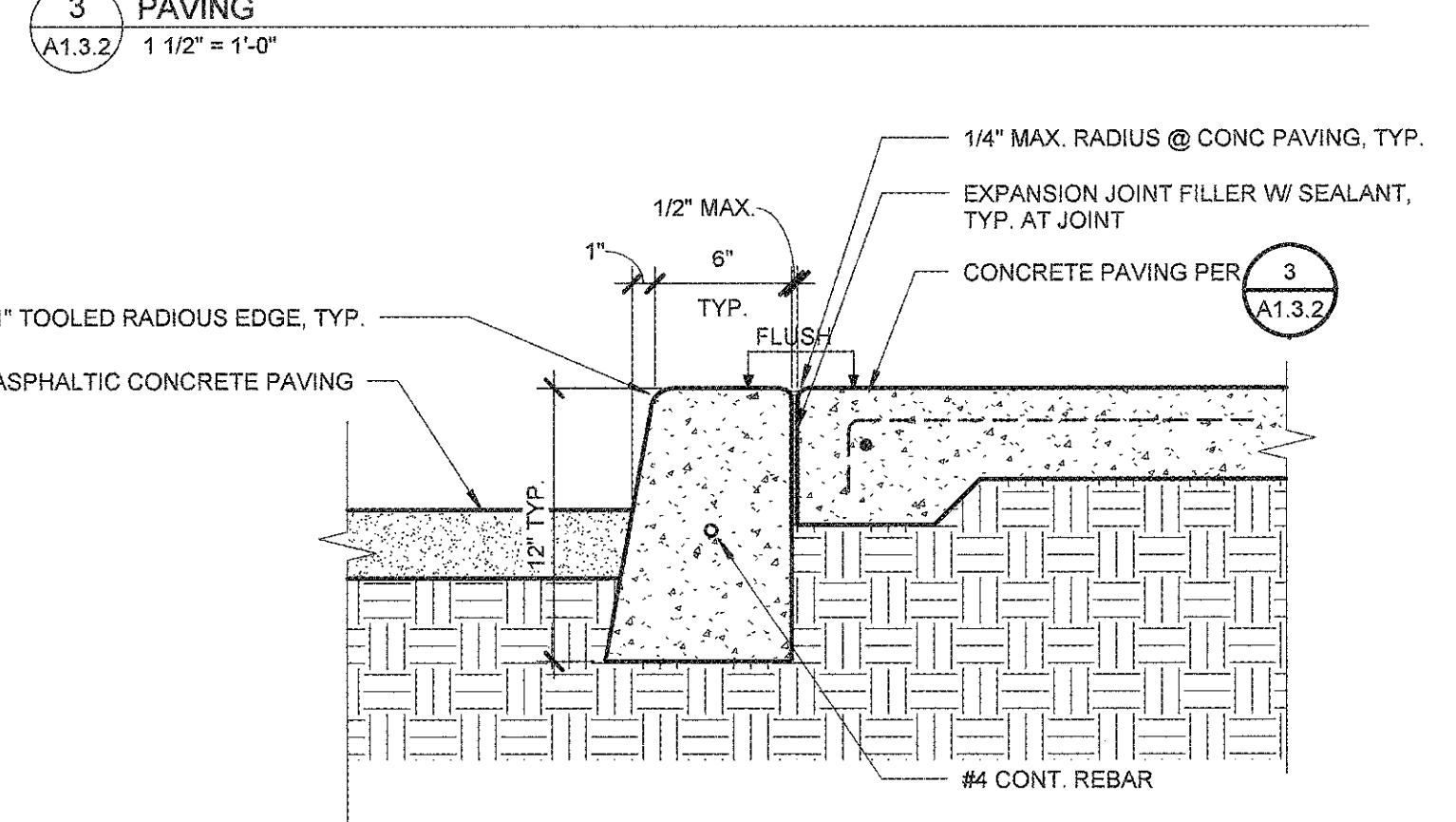

4 TYP. CONCRETE CURB TO ASPHALT PAVING
A1.3.2 1 1/2\"/>

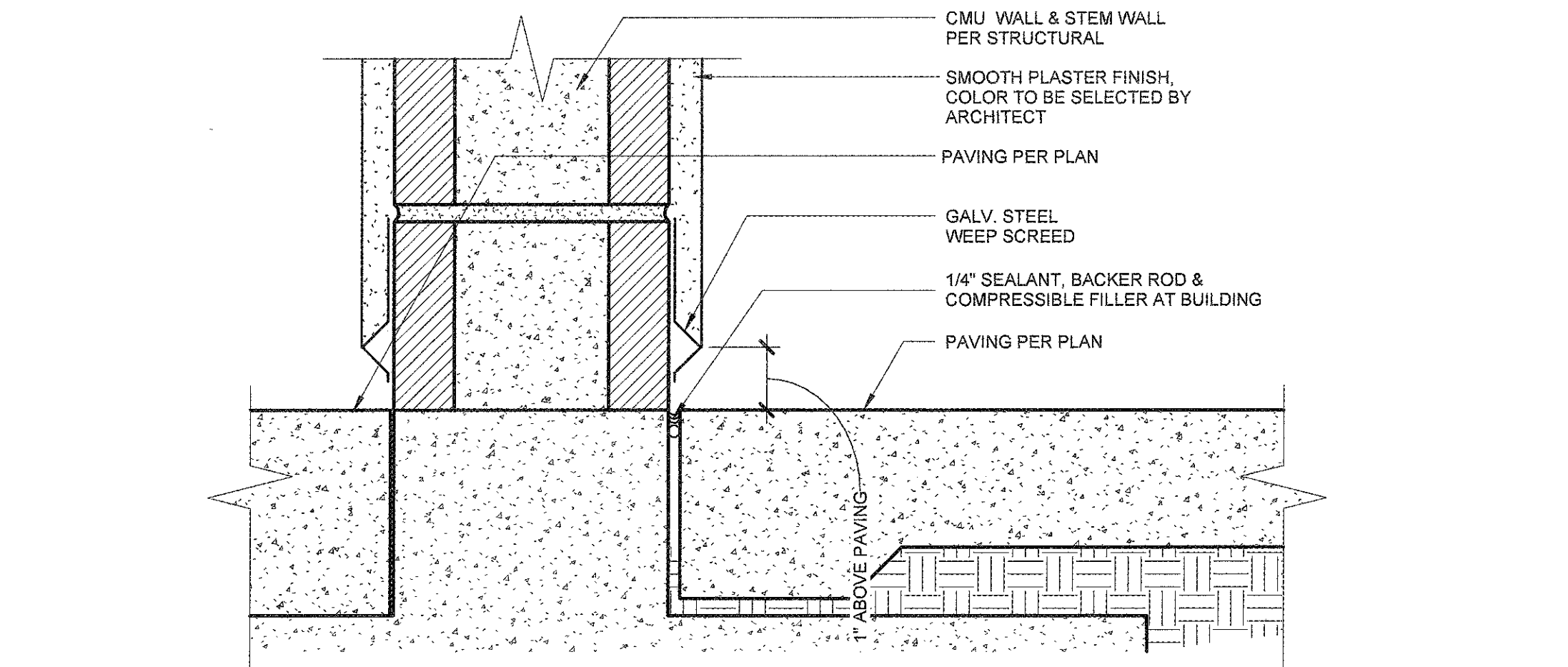

18 WEEP SCREED DETAIL
A1.3.2 3\"/>

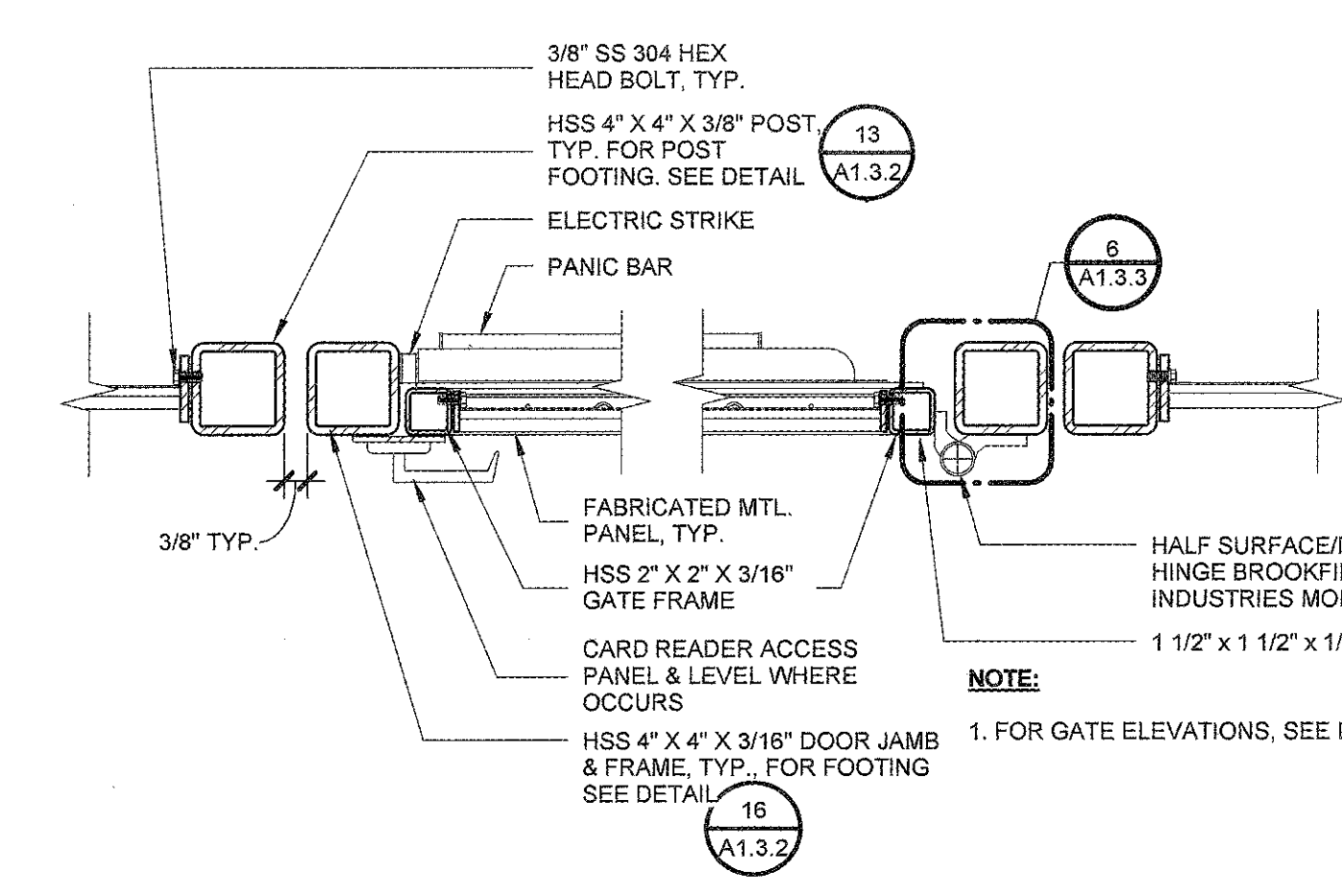

14 TYP. GATE SECTION
A1.3.2 1 1/2\"/>

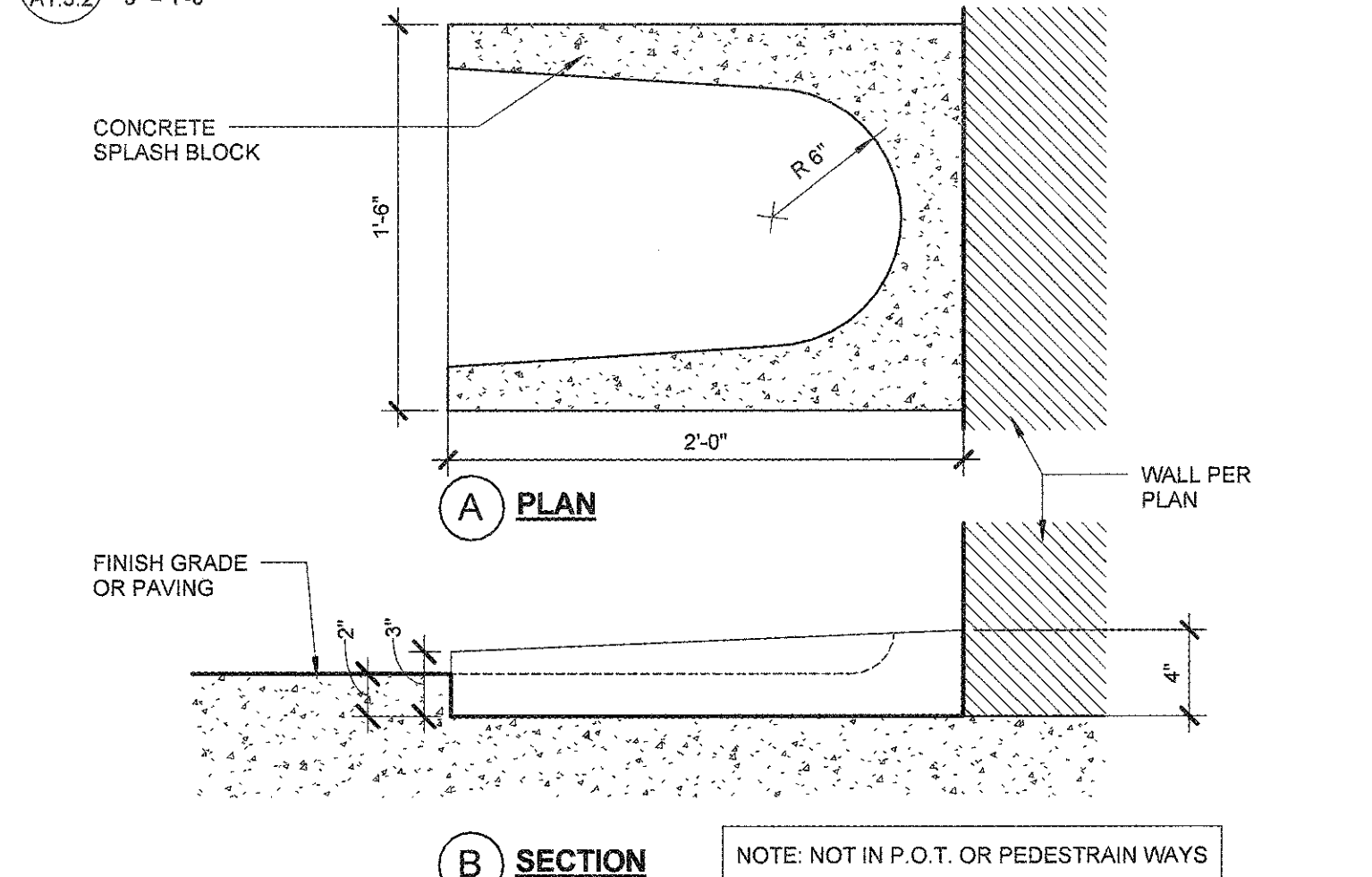

10 TYP. CONCRETE SPLASH BLOCK ON GRADE
A1.3.2 1 1/2\"/>

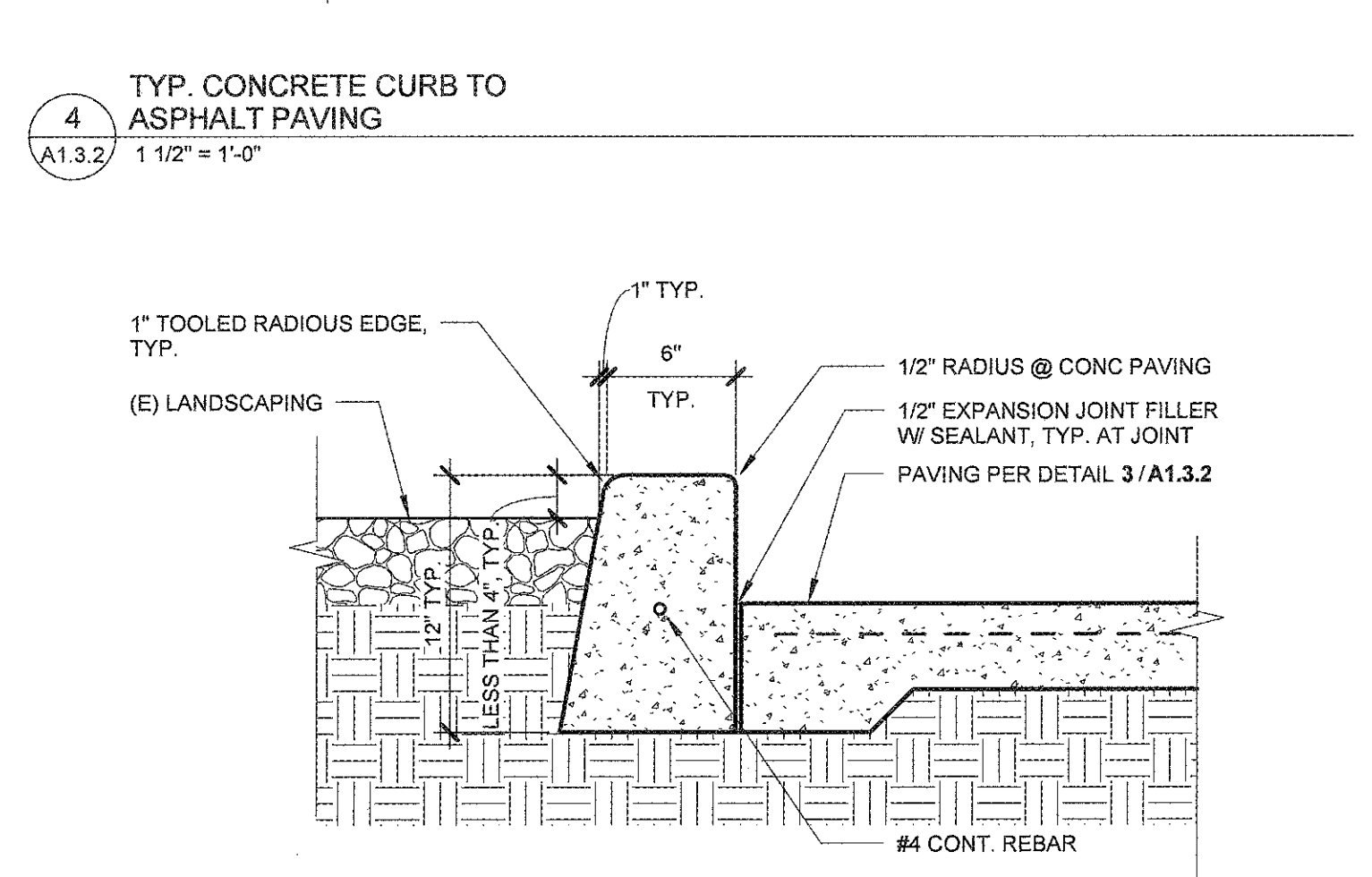

5 TYP. CONCRETE CURB TO EXISTING LANDSCAPING
A1.3.2 1 1/2\"/>

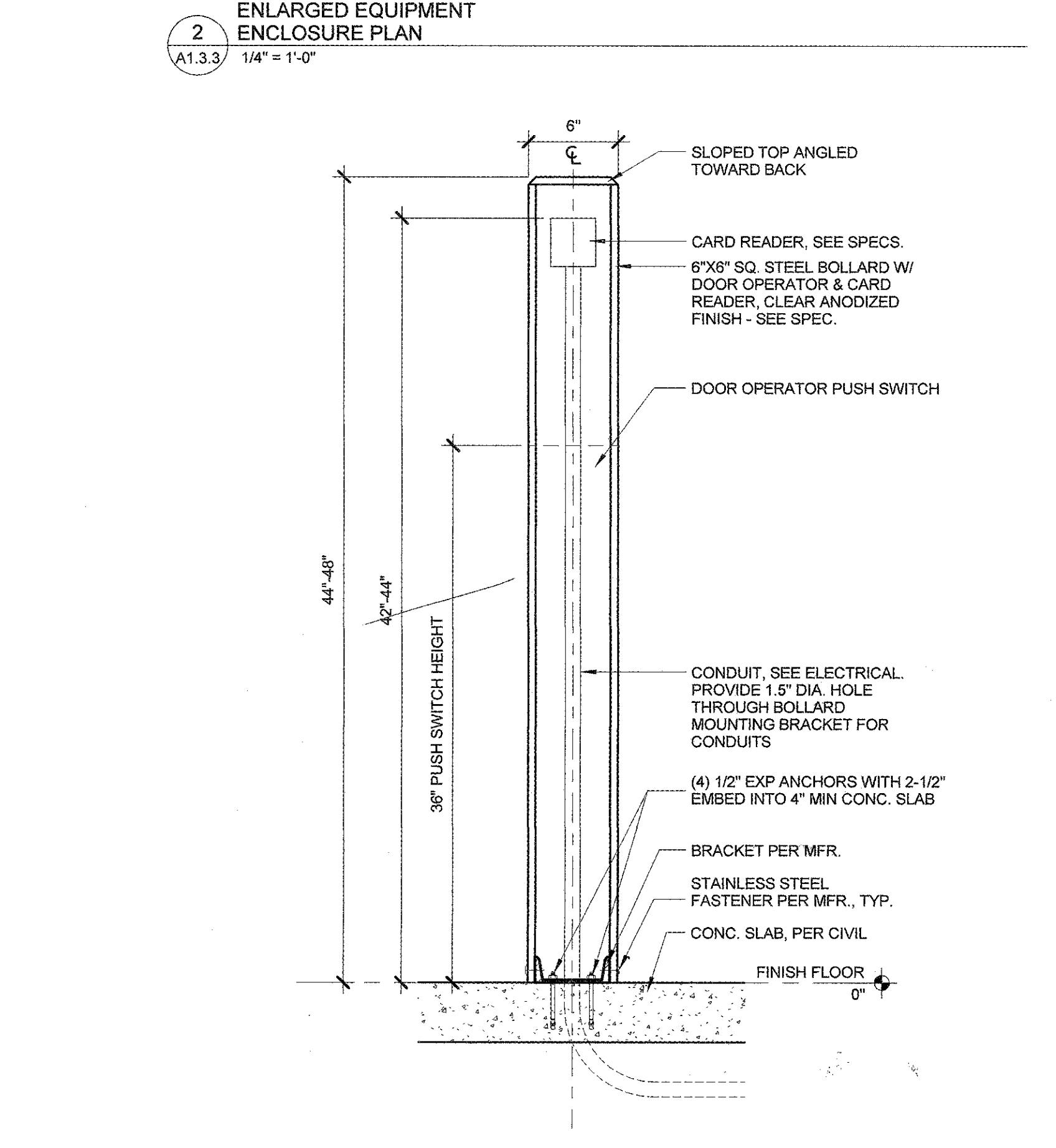
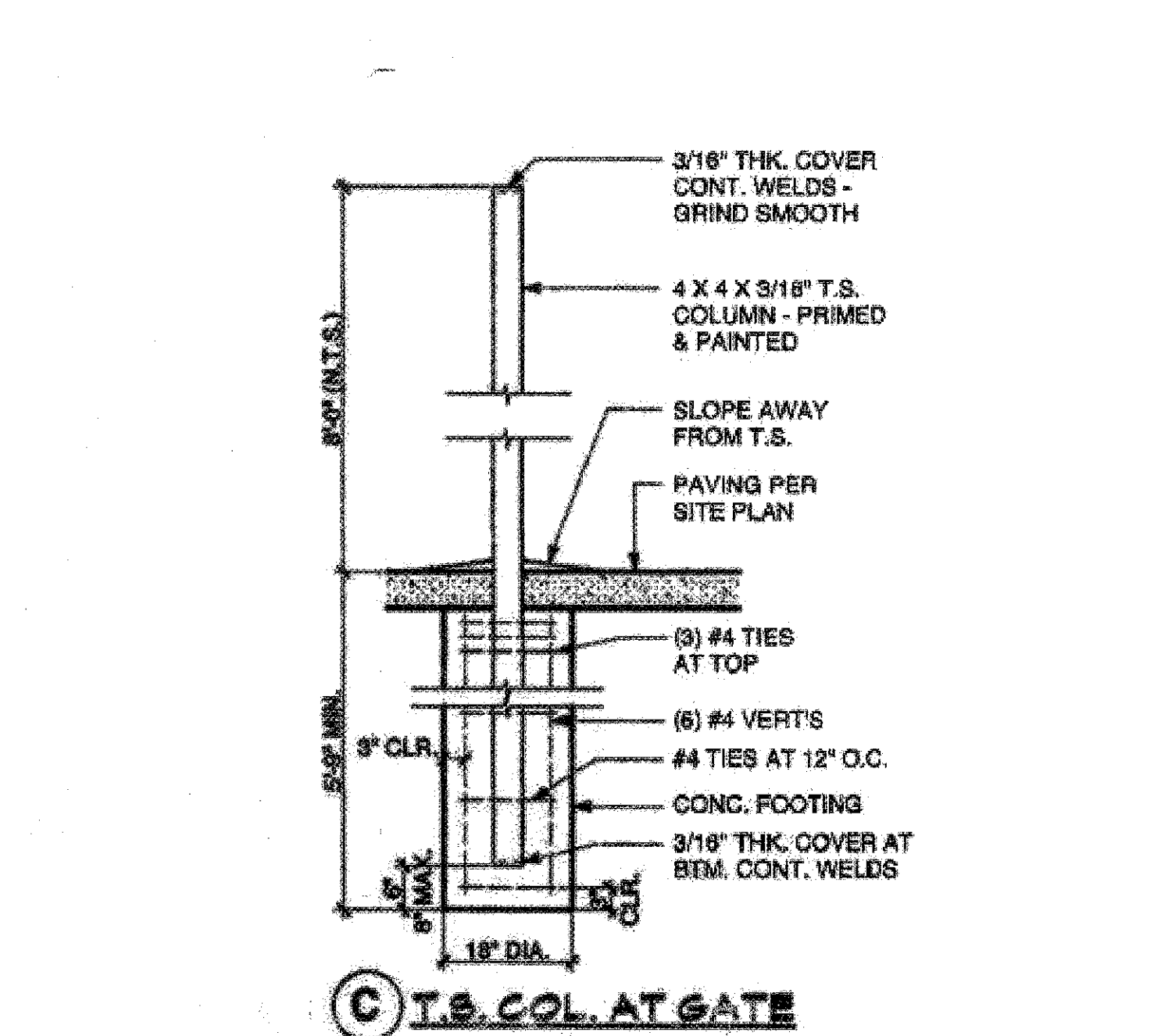
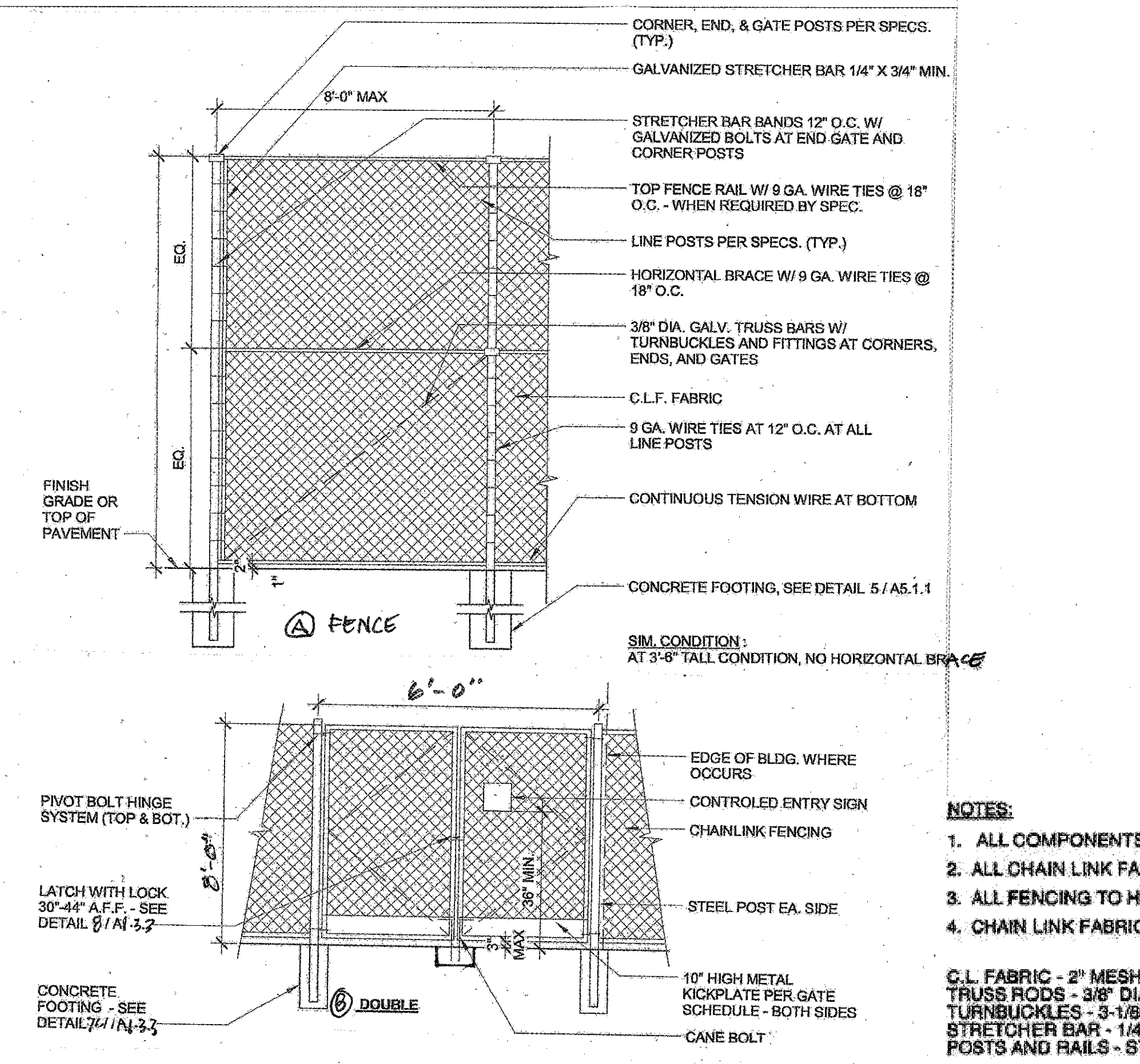
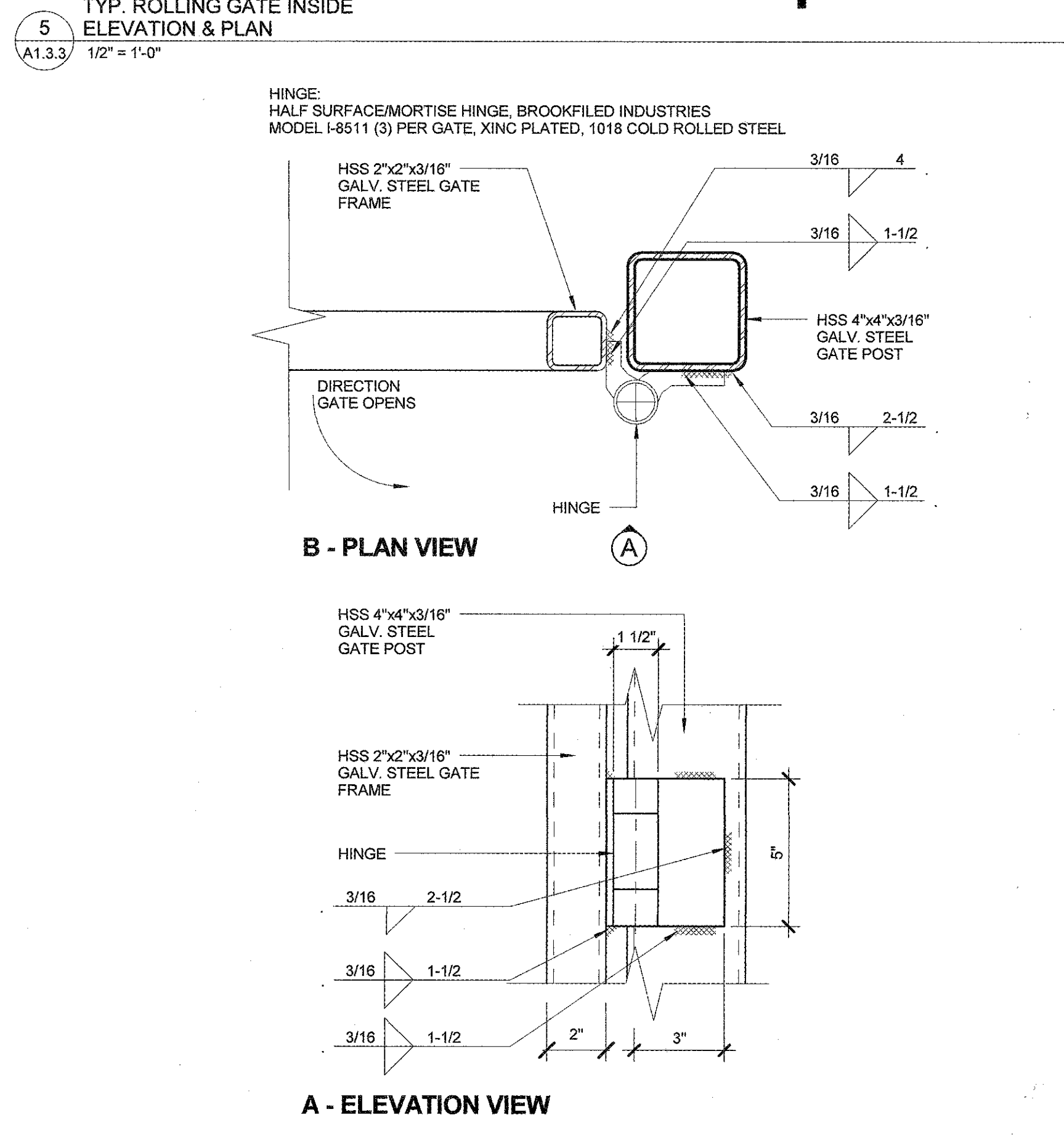
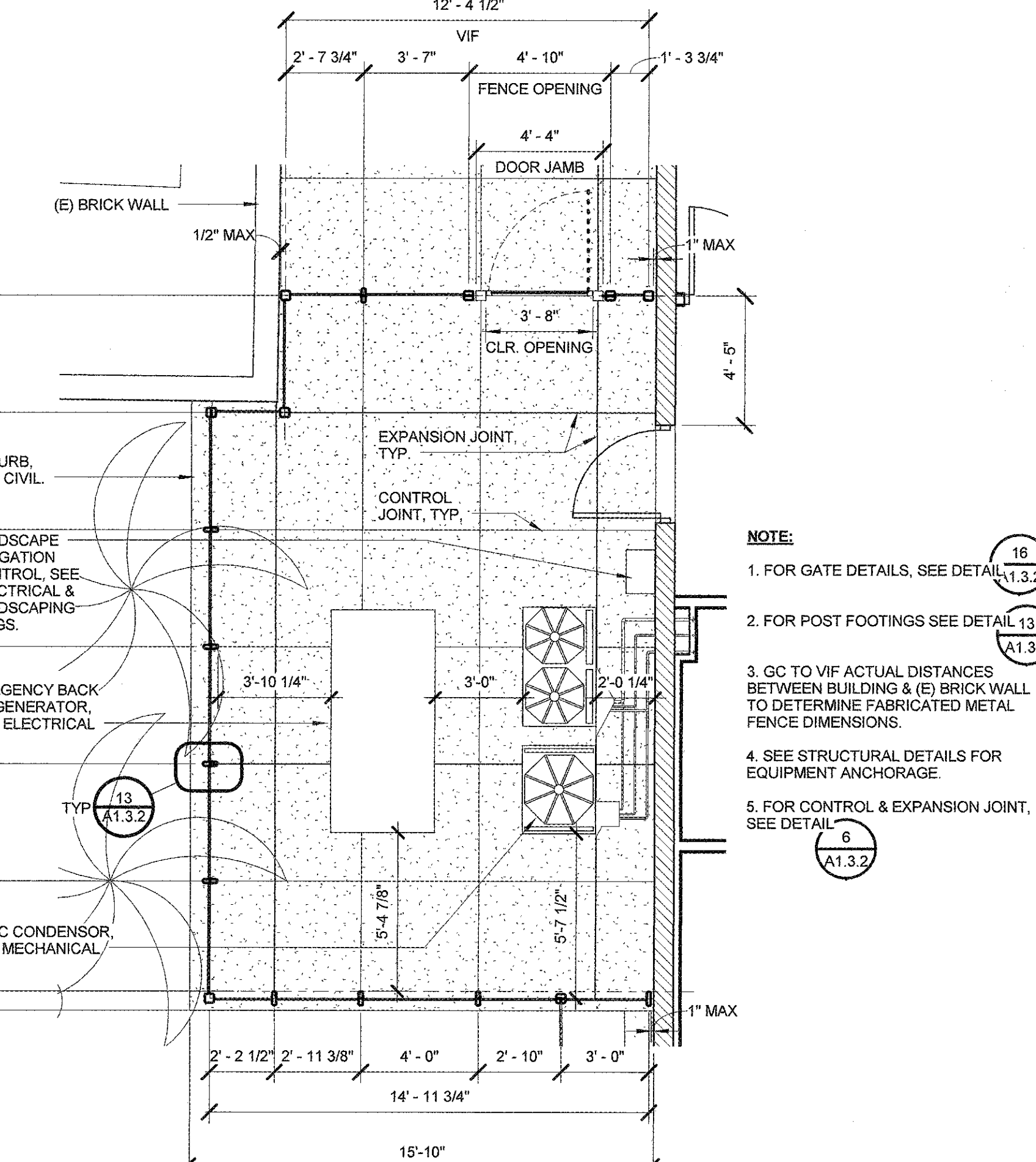
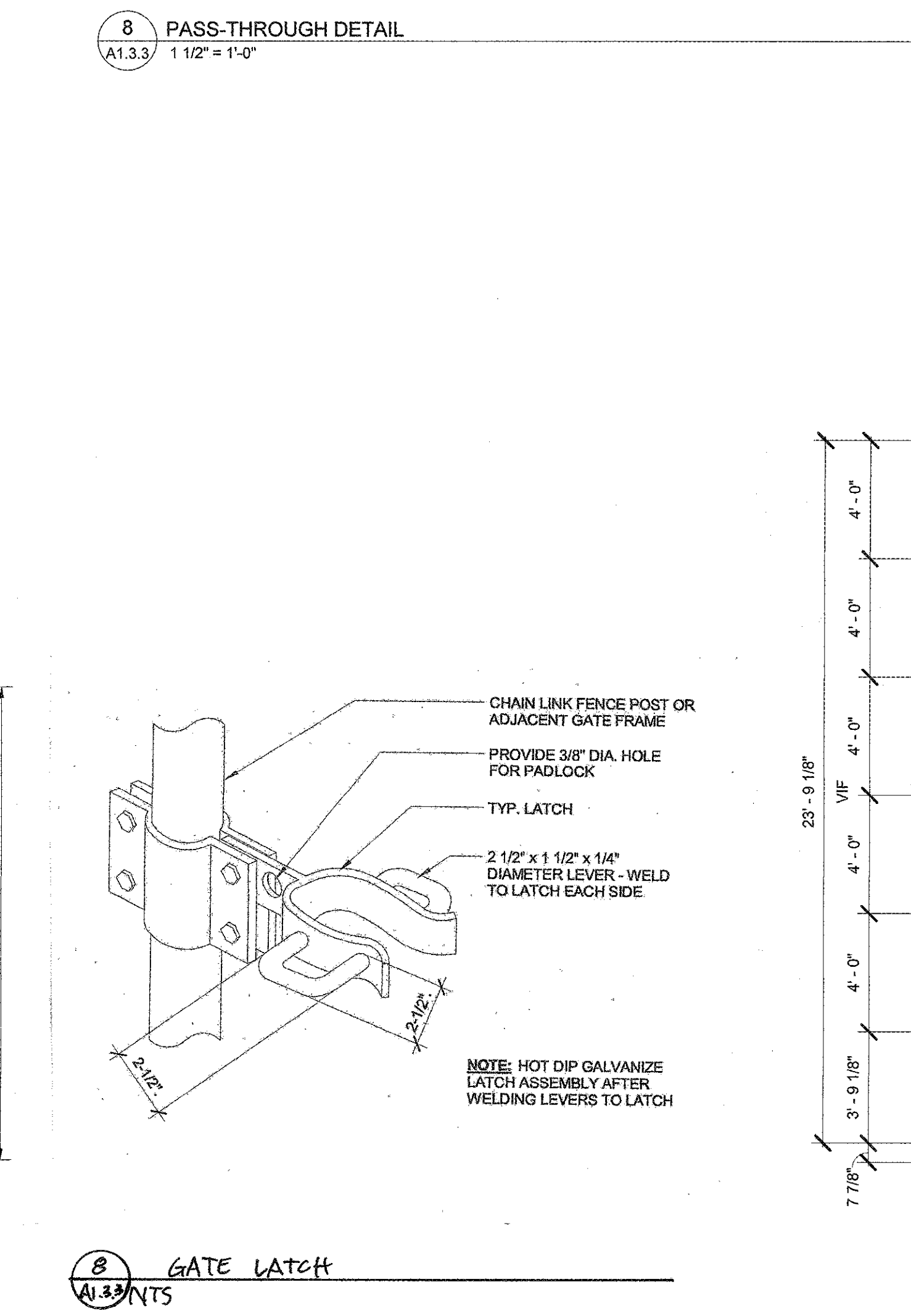
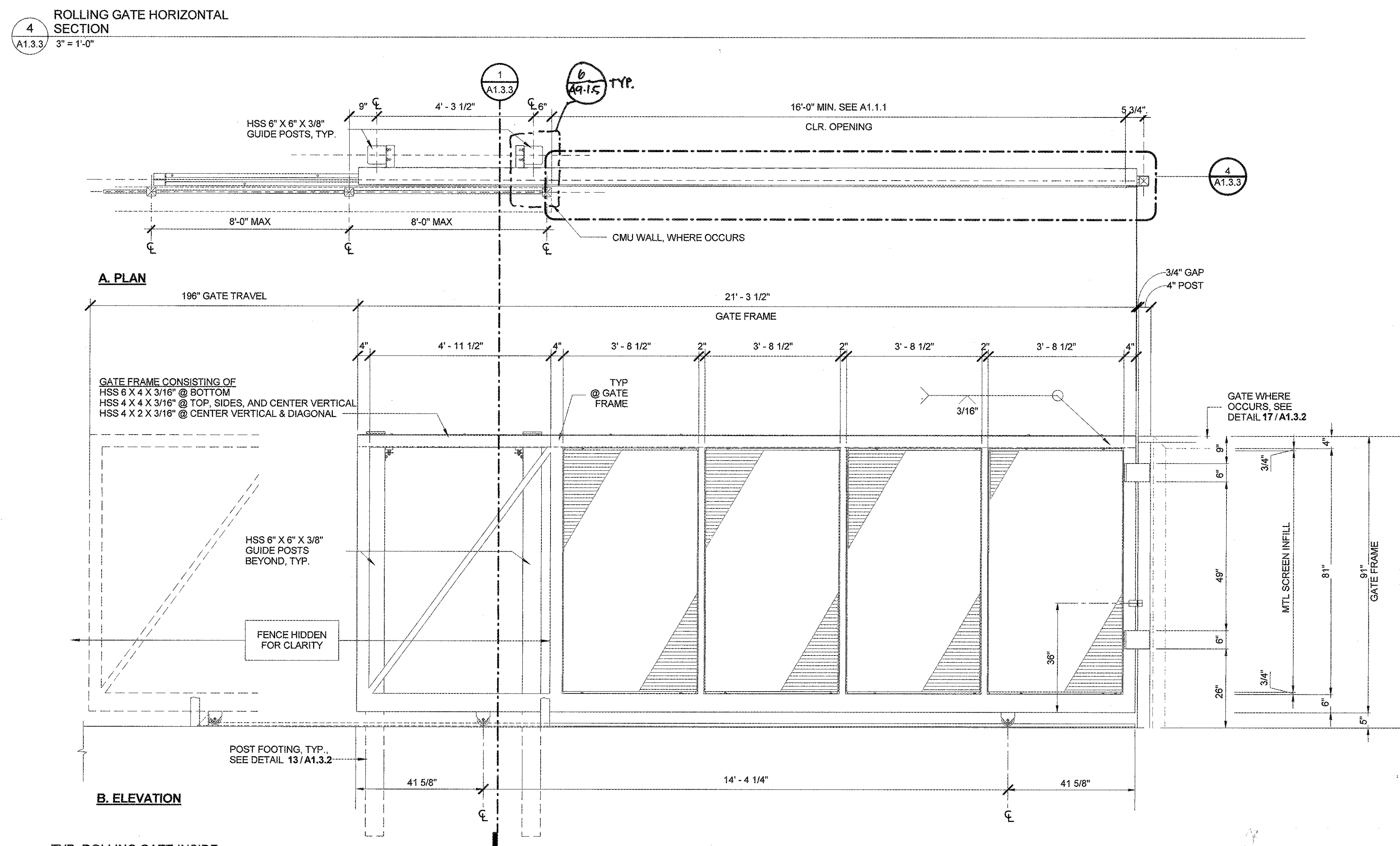
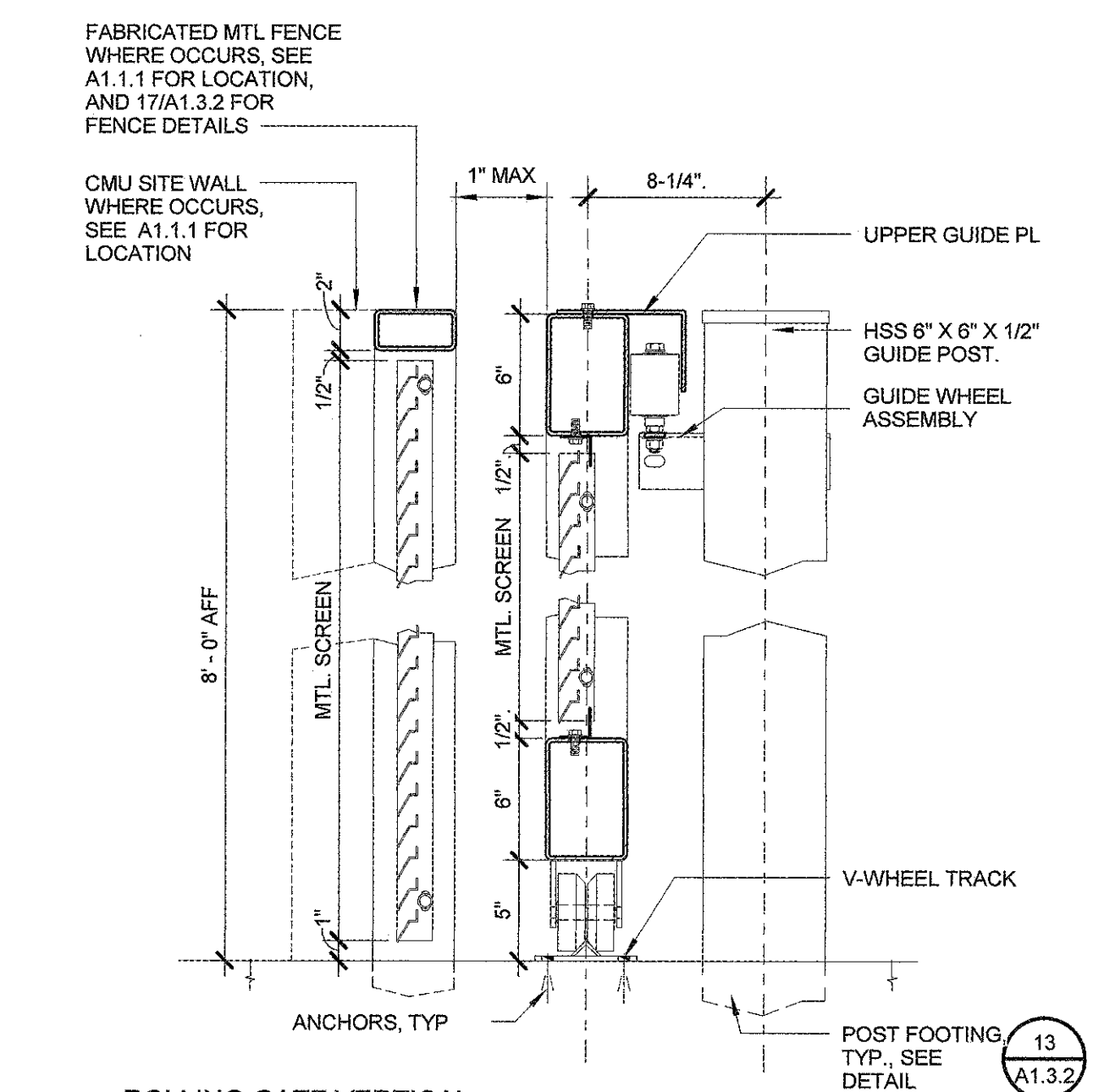
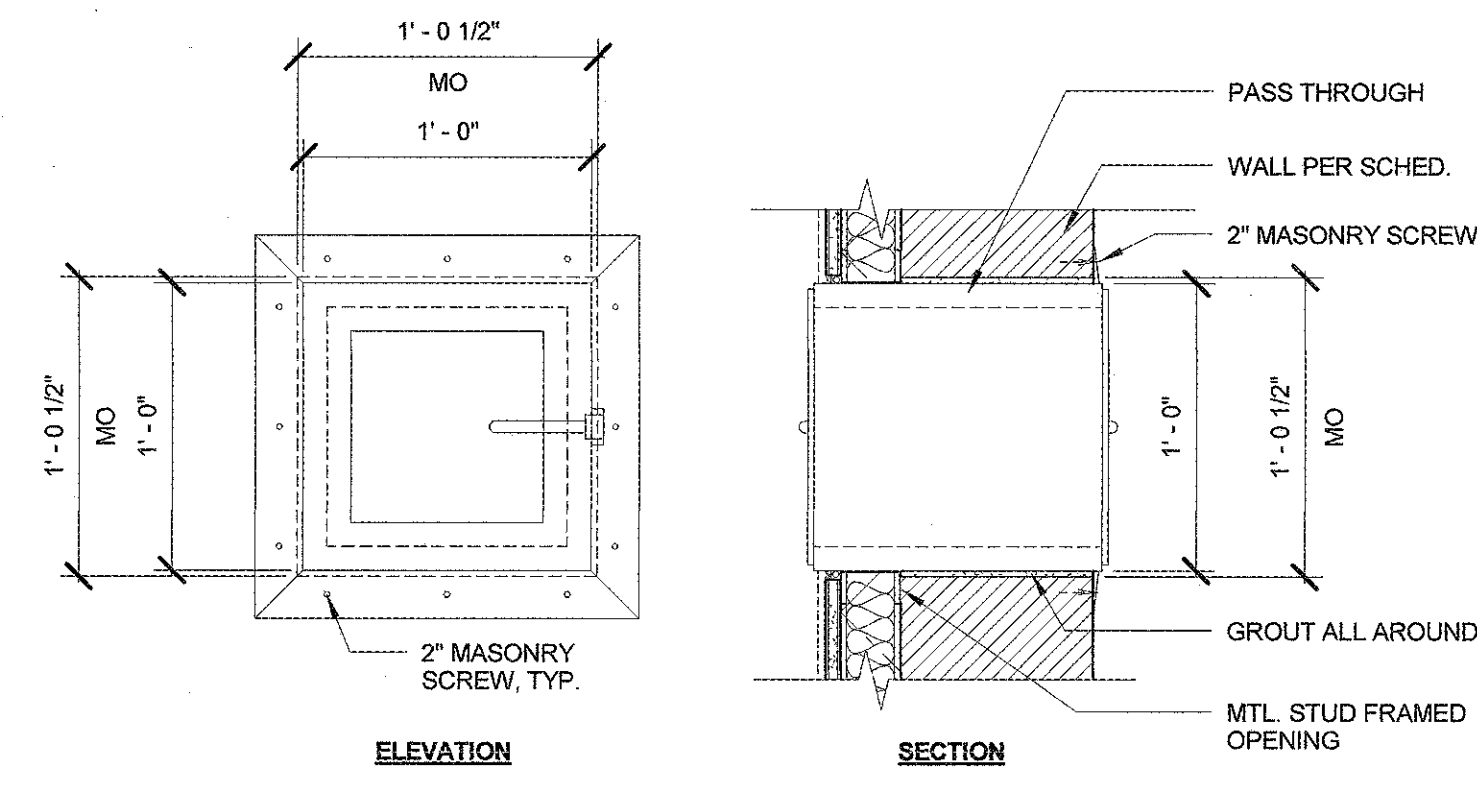
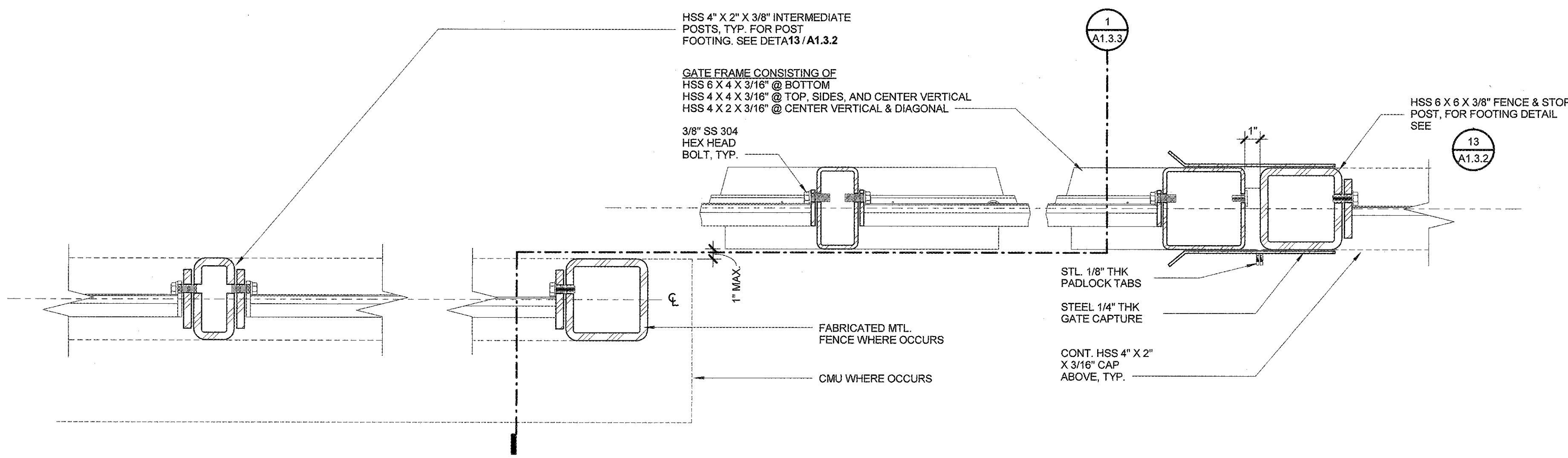

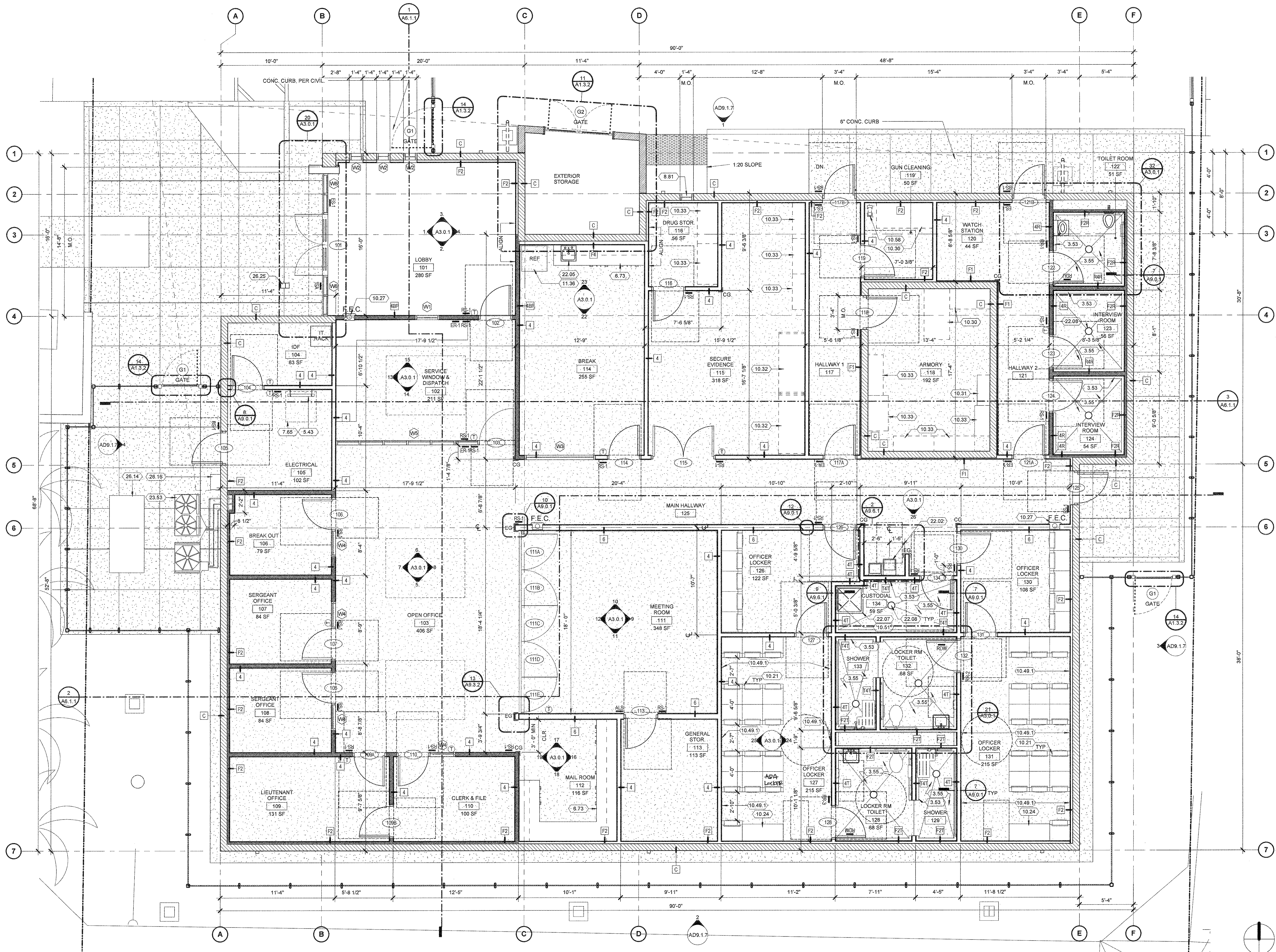

1 FINISH FLOOR
A2.1.1 / 1/4" = 1'-0"

- KEYNOTES**
- 3.53 CONCRETE COVE BASE, TYP. SEE DET. 6 & 7/A9.0.1
 - 3.55 2-1/2" DEPRESSED CONCRETE SLAB PER STRUCTURAL
 - 5.43 PREFABRICATED ALUMINUM ACCESS LADDER, SEE DETAIL 7/A9.1.1 - 05 50 00
 - 6.73 LAMINATE COUNTERTOP, SEE INT. ELEVATION FOR MORE INFORMATION - 06 41 00
 - 7.65 ROOF ACCESS HATCH - 07 72 00
 - 8.81 STEEL PASS-THROUGH EVIDENCE DROP-OFF, SEE DETAIL 8/A1.3.3
 - 10.21 LOCKERS, SEE DETAIL 17/A9.6.1 - 10 51 13
 - 10.24 48" x 24" ADA BENCH, SEE 4/A9.6.1 FOR ANCHORAGE - 10 51 13
 - 10.27 FIRE EXTINGUISHER CABINET, SEMI-RECESSED, SEE DETAIL 6/A9.6.1 - 10 44 00
 - 10.30 ROUSSEAU DESK WITH UPPER WALL MOUNT UNITS - 10 56 13
 - 10.31 WEAPONWRX SHELVING - 10 56 13
 - 10.32 WIDESPAN SHELVING - 10 56 13
 - 10.33 SPACESAVER 4-POST METAL STORAGE SHELVING - 10 56 13
 - 10.49.1 LOCKER ROOM FULL HEIGHT MIRROR, TYP. - 10 28 00
 - 10.51 MOP RACK - 10 28 00
 - 10.58 EMERGENCY-CLEAR CLEARING BARREL SIDE BY SIDE OR FREEZER ON BOTTOM REFRIGERATOR TO BE OWNER PROVIDED, OWNER INSTALLED, NIC
 - 11.36 DRINKING FOUNTAIN, PER PLUMBING DRAWINGS
 - 22.02 SINK, PER PLUMBING DRAWINGS
 - 22.07 MOP SINK, PER PLUMBING DRAWINGS
 - 22.08 FLOOR DRAIN, PER PLUMBING DRAWINGS
 - 23.53 HVAC CONDENSING UNIT, PER MECHANICAL - 23 65 00
 - 26.14 EMERGENCY GENERATOR, PER ELECTRICAL
 - 26.16 IRRIGATION CONTROL PANEL, PER LANDSCAPING & ELECTRICAL
 - 26.25 O.I.C.F. SITE POLE LIGHTING & CONCRETE BASE PER 7/E0.0.6, TYP. SEE ELECTRICAL

- SIGNAGE SCHEDULE**
- ER-1 EXIT ROUTE, SEE DETAIL 3/A9.6.2
 - ES-1 EXIT SIGNAGE, SEE DETAIL 3/A9.6.2
 - ALS ASSISTED LISTENING SYSTEM 11/A9.6.2
 - RS-1 TYP. ROOM SIGNAGE, SEE DETAIL 5/A9.6.2
 - BS-1 EXTERIOR BUILDING SIGNAGE, SEE DETAIL 5/A9.6.2
 - RR-1 RESTROOM SIGNAGE ON WALL, SEE DETAIL 6/A9.6.2
 - RRW FROM RDU RESTROOM SIGNAGE ON DOOR, SEE DETAIL 6/A9.6.2

- WALL LEGEND**
- WALL TYPES PER SHEET A9.0.1
 - NON-RATED PARTITION
 - ACOUSTICAL PARTITION
 - EG CORNER & END WALL GUARDS, SEE DETAIL 10/A9.0.1 & SPEC. SECTION 10 26 00

- GENERAL NOTES**
1. FIRST FLOOR FINISH FLOOR IS ASSUMED TO BE 0'-0"; REFER TO CIVIL FOR ACTUAL ELEVATION
 2. DOOR FRAMES LOCATED NEAR ADJACENT WALLS OR CASEWORK TO BE 4" FROM INSIDE CORNER, OR TO NEAREST BLOCK MODULE AT CMU WALLS, U.N.O.
 3. COORDINATE AND CONFIRM EXACT LOCATIONS OF ALL FLOOR MOUNTED OUTLETS PRIOR TO CONCRETE PLACEMENT, SEE ELECT.
 4. FOR WALL TYPES, SEE SHEET A9.0.1, A9.0.2 & REFER TO STRUCTURAL FOR TYPICAL WALL FRAMING DETAILS.
 5. FOR TYPICAL MOUNTING AND ACCESSIBILITY HEIGHTS, SEE SHEET A3.0.1
 6. FOR ALL WALLS THAT REQUIRE BACKING, PROVIDE 18 GA MTL STUDS
 7. SEE DETAIL 9/A9.3.1 FOR TRANSITIONS STRIPS BETWEEN MATERIALS
 8. ROOM IDENTIFICATION SIGNAGE - SPEC SECTION 10 14 00 FOR MOUNTING HEIGHT SEE DETAIL 9/A9.6.2
 9. TOILET ROOM SYMBOLS - SPEC SECTION 10 14 00. FOR MOUNTING HEIGHT SEE DETAIL 6 & 7/A9.6.2
 10. SEE DETAIL 15/A9.6.1 FOR FLOOR AND WALL ANCHORAGE OF ROUSSEAU DESK WITH UPPER WALL MOUNTED UNITS, WEAPONWRX SHELVING, WIDESPAN SHELVING, AND SPACESAVER 4-POST METAL STORAGE SHELVING UNITS.
 11. PROVIDE (1) ACCESSIBLE LOCKER AT EACH LOCKER ROOM.
 12. PROVIDE CURB IN ALL RESTROOMS, SHOWERS, TOILETS, CUSTODIAL ROOM, AND INTERVIEW ROOMS. PER DETAIL 7/A9.0.1

LITTLE
DIVERSIFIED ARCHITECTURAL CONSULTING

1300 Dove Street, Suite 100
Newport Beach, CA 92660
T: 949.698.1400 F: 949.698.1433

www.littleonline.com

This drawing and the design shown are the property of Little Diversified Architectural Consulting. The reproduction, copying or other use of this drawing without their written consent is prohibited and any infringement will be subject to legal action.

© Little 2016

**COMPTON
CCD**

CAMPUS PUBLIC SAFETY BUILDING

**1111 EAST ARTESIA BOULEVARD,
COMPTON CALIFORNIA 90221**

IDENTIFICATION STAMP
DIV. OF THE STATE ARCHITECT
OFFICE OF REGULATION SERVICES

FILE NO: 19-C1
AP: 03-117673

DATE: DEC. 1.2.2017

PROJECT MANAGER
RITA S. CARTER

PROJECT MANAGER
SHOJI TAKESHIMA / DAVID PHAN

DRAWN BY
DAVID PHAN

NO REASON DATE



FLOOR PLAN

PROJECT NUMBER: 913-4675-00

DATE: 12/01/16 SHEET NO: A2.1.1

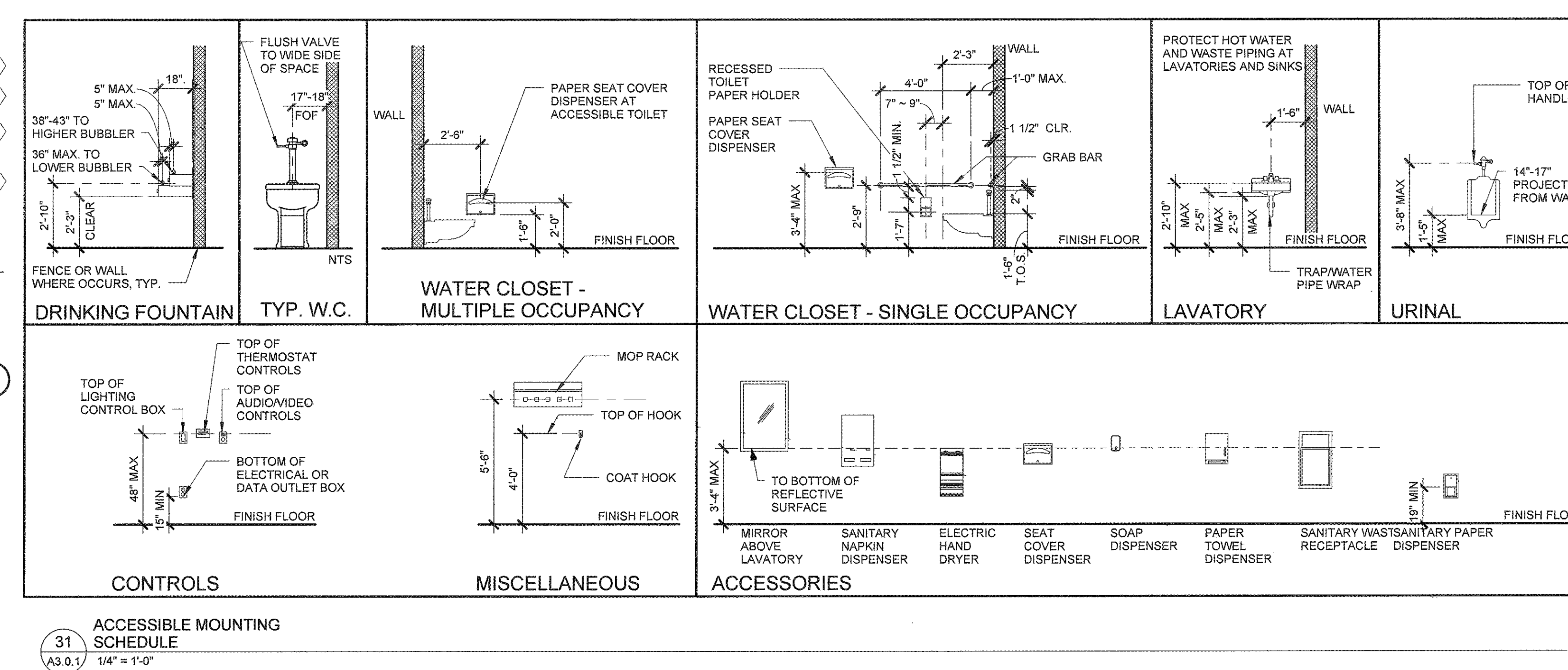
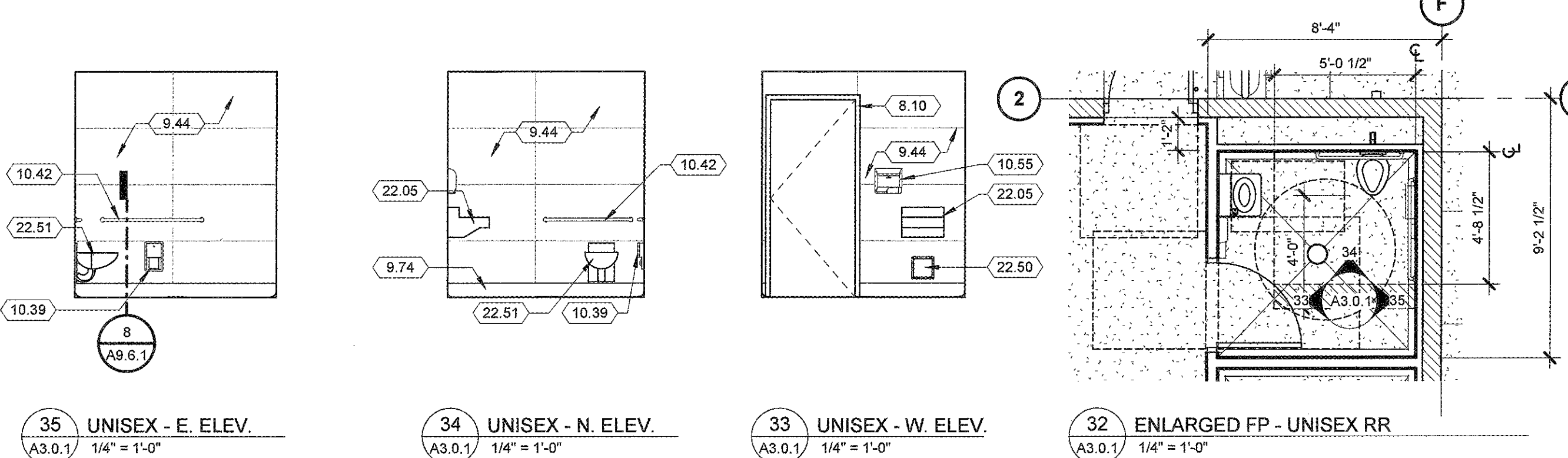
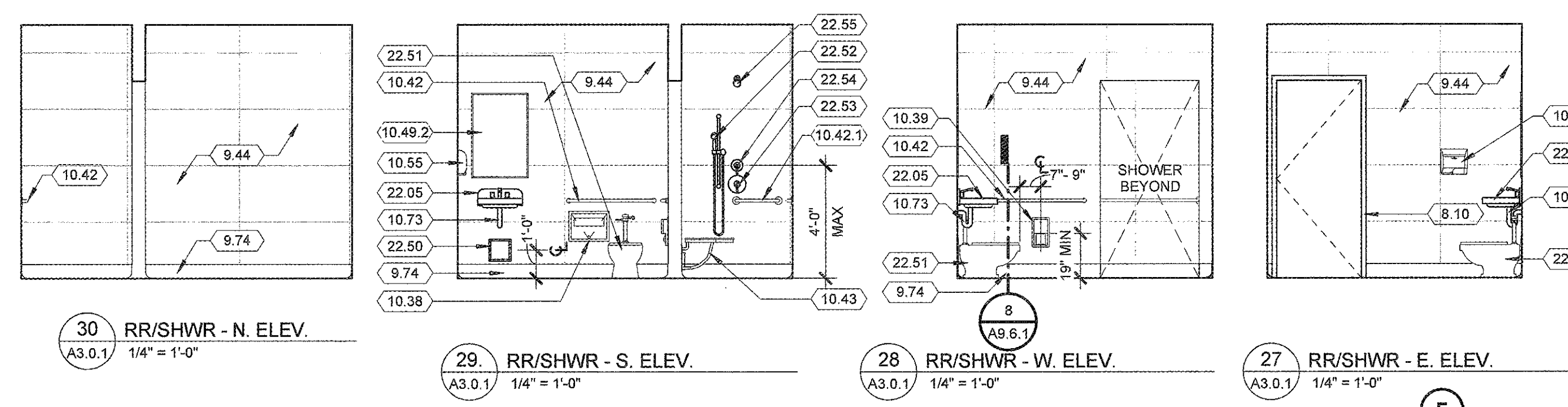
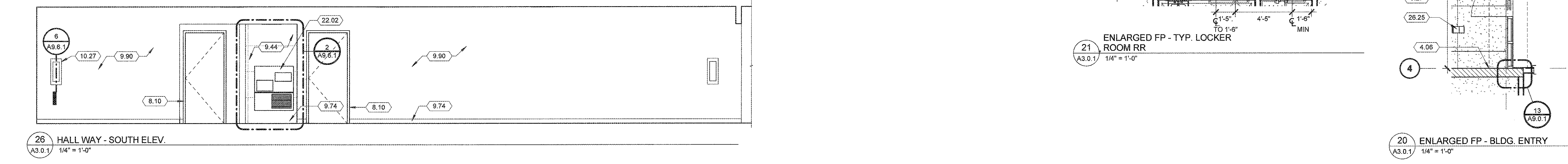
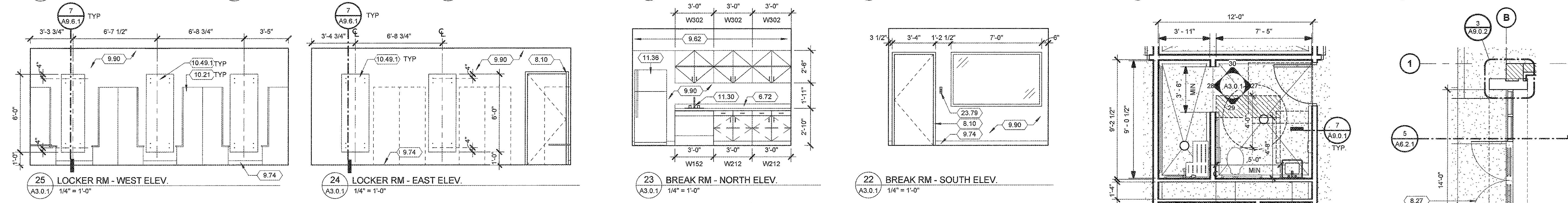
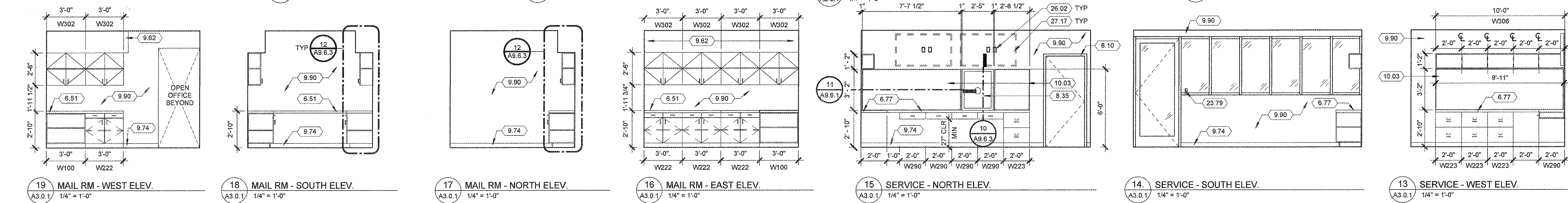
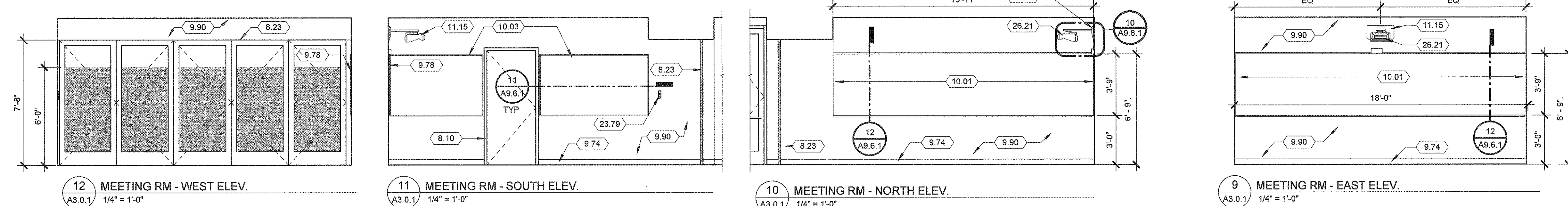
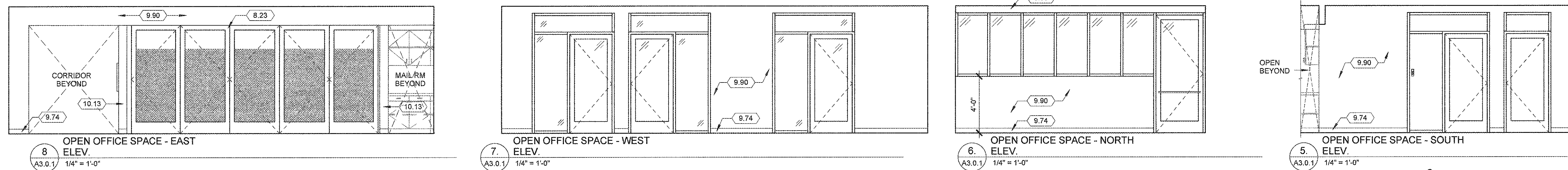
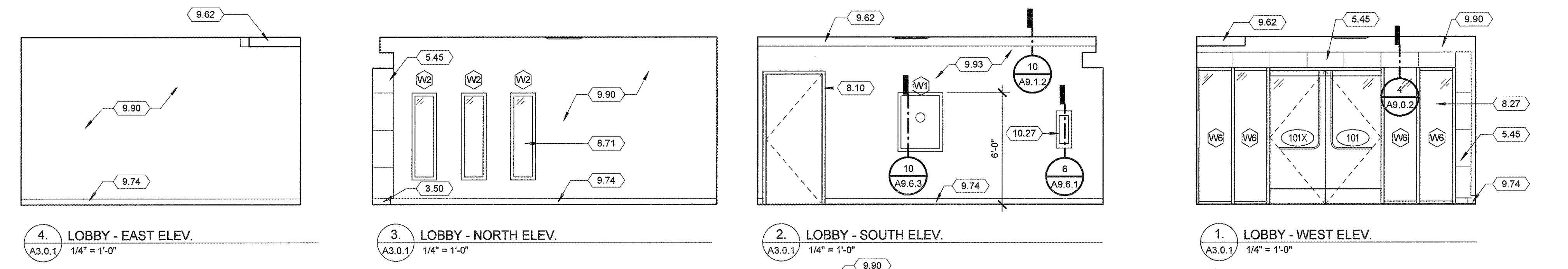

- KEYNOTES**
- 3.50 EXPOSED CAST-IN-PLACE CONCRETE - 32 30 00
 - 4.06 CONCRETE MASONRY UNIT CMU - 04 22 00
 - 5.45 COMPOSITE METAL PANEL SYSTEM - 07 42 13
 - 6.51 PLASTIC LAMINATE COUNTERTOP - 06 41 00
 - 6.72 PLASTIC LAMINATE COUNTERTOP WITH BACKSLASH - 06 41 00
 - 6.77 STAINLESS STEEL LAMINATED COUNTERTOP - 06 41 00
 - 8.10 PREFINISHED HOLLOW METAL FRAMES - 08 12 13
 - 8.23 GLASS PANEL DOORS - 08 35 14
 - 8.27 ALUMINUM STOREFRONT SYSTEM - 08 41 00
 - 8.35 ALUMINUM PASS THRU WINDOW - 08 58 00
 - 8.71 TUBULAR SKYLIGHT, TYPE 2 - 08 62 00
 - 9.44 CERAMIC TILE - 09 30 13
 - 9.62 SOFFIT, SEE DETAIL 10/A9.1.2
 - 9.74 WALL BASE, SEE FINISH SCHEDULE - 09 65 00
 - 9.78 NON-GLARE, PROJECTABLE MARKERBOARD WALL COVERING - 09 72 00
 - 9.90 PAINT FINISH - INTERIOR, SEE FINISH SCHEDULE - 09 91 00
 - 9.93 VINYL WALL COVERING - 09 72 17
 - 10.01 NON-GLARE, PROJECTABLE MARKERBOARD WALL COVERING - 10 11 16
 - 10.03 TACKBOARD PANEL - 10 11 16
 - 10.13 CORNER/END GUARD(S) - 10 26 13
 - 10.21 LOCKERS, SEE DETAIL 17/A9.6.1 - 10 51 13
 - 10.27 FIRE EXTINGUISHER CABINET, SEMI-RECESSED, SEE DETAIL 6/A9.6.1 - 10 44 00
 - 10.38 SEAT COVER DISPENSER - 10 28 00
 - 10.39 SANITARY PRODUCTS DISPENSER - 10 28 00
 - 10.42 GRAB BAR - 10 28 00
 - 10.42.1 SHOWER GRAB BAR - 10 28 00
 - 10.43 FOLDING SHOWER SEAT - 10 28 00
 - 10.49.1 LOCKER ROOM FULL HEIGHT MIRROR, TYP. - 10 28 00
 - 10.49.2 RESTROOM MIRROR - 10 28 00
 - 10.55 ELECTRIC HAND DRYER - 10 28 00
 - 10.73 BURN PROTECTION TRAP/WATER PIPE WRAP - 10 28 00
 - 11.15 PROJECTOR MOUNT - 11 52 00
 - 11.30 STAINLESS STEEL SINK, SEE PLUMBING
 - 11.36 SIDE BY SIDE OR FREEZER ON BOTTOM REFRIGERATOR TO BE OWNER PROVIDED, OWNER INSTALLED, NIC
 - 22.02 DRINKING FOUNTAIN, PER PLUMBING DRAWINGS
 - 22.05 SINK, PER PLUMBING DRAWINGS
 - 22.50 RECESSED HOSE BIB BOX, SEE PLUMBING
 - 22.51 WALL HUNG TOILET, SEE PLUMBING
 - 22.52 HAND SHOWER, SEE PLUMBING
 - 22.53 THERMOSTATIC MIXING VALVE, SEE PLUMBING
 - 22.54 DIVERTER, SEE PLUMBING
 - 22.55 SHOWER HEAD, SEE PLUMBING
 - 23.79 THERMOSTAT CONTROLLER, SEE MECHANICAL
 - 26.02 ELECTRICAL & DATA OUTLETS, SEE ELECTRICAL
 - 26.21 PROJECTOR, SEE DET. 10/A9.6.1 FOR MOUNTING
 - 26.25 O.I.C.F. SITE POLE LIGHTING & CONCRETE BASE PER 7/E0.6, TYP., SEE ELECTRICAL
 - 27.17 SECURITY MONITORS OWNER PROVIDED & INSTALLED, TYP. SEE DET. 13/A9.6.1 FOR MOUNTING DETAIL

CASEWORK SCHEDULE

TYPE	DETAIL #
W100	1/A9.6.3
W152	4/A9.6.3
W212	2/A9.6.3
W222	2/A9.6.3
W223	3/A9.6.3
W290	5/A9.6.3
W302	7/A9.6.3
W308	8/A9.6.3

- GENERAL NOTES**
1. ALL MILLWORK FINISH IS PL-2 FOR UPPER AND PL-3 FOR LOWER CABINETS, U.O.N.
 2. ALL COUNTERTOPS ARE PL-1, U.O.N.
 3. ALL PLAM GRAIN TO RUN VERTICAL
 4. SEE SPEC SECTION 06 41 00 FOR ACCESSORIES AND ADDITIONAL INFORMATION.
 5. MILLWORK BASED ON ARCHITECTURAL WOODWORK STANDARDS CABINET DESIGN SERIES.
 6. DIMENSIONS SHOWN OF CASEWORK WIDTH ARE GENERAL ESTIMATIONS GIVING DESIGN INTENT. GENERAL CONTRACTOR TO FIELD VERIFY OVERALL DIMENSIONS OF CASEWORK LOCATION AND ADJUST CASEWORK DIMENSIONS ACCORDINGLY.
 7. SCRIBE BASE CABINET END PANELS TO MATCH SELF COVE BASE PROFILE WHERE OCCURS.
 8. FOR ACCESSIBLE FIXTURES AND EQUIPMENT HEIGHTS, REFER TO 31/A3.0.1

LITTLE
DIVERSIFIED ARCHITECTURAL CONSULTING

1300 Dove Street, Suite 100
Newport Beach, CA 92660
T: 949.698.1400 F: 949.698.1433
www.littleonline.com

This drawing and the design shown are the property of Little Diversified Architectural Consulting. The reproduction, copying or other use of this drawing without their written consent is prohibited and any infringement will be subject to legal action.

© Little 2016

COMPTON CCD

CAMPUS PUBLIC SAFETY BUILDING

1111 EAST ARTESIA BOULEVARD,
COMPTON CALIFORNIA 90221

IDENTIFICATION STAMP
DIV. OF THE STATE ARCHITECT
OFFICE OF REGULATION SERVICES

FILE NO: 19-C1
AR: 03-117673
DATE: DEC 12 2017

PRINCIPAL IN CHARGE
RITA S. CARTER

PROJECT MANAGER
SHOJI TAKESHIMA / DAVID PHAN

DRAWN BY
DAVID PHAN

NO REASON DATE

DETAILED FLOOR PLANS & INTERIOR ELEVATIONS

913-4675-00

12/01/16 A3.0.1

- LEGEND
- 5.43 PREFABRICATED ALUMINUM ACCESS LADDER, SEE DETAIL 7/A9.1.1 - 05 50 00
 - 5.51 HOT DIP GALVANIZED CANOPY STRUCTURAL FRAMING, PER STRUCTURAL - 05 12 00
 - 7.65 ROOF ACCESS HATCH - 07 72 00
 - 8.15 CEILING ACCESS PANEL, SEE DET. 13/A9.1.2 - 08 31 13
 - 8.80 CLERESTORY WINDOW
 - 10.72 BIRD NETTING - 10 81 13
 - 26.07 LIGHT FIXTURE, SEE ELECTRICAL

LITTLE
DIVERSIFIED ARCHITECTURAL CONSULTING

1300 Dove Street, Suite 100
Newport Beach, CA 92660
T: 949.698.1400 F: 949.698.1433
www.littleonline.com

This drawing and the design shown are the property of Little Diversified Architectural Consulting. The reproduction, copying or other use of this drawing without their written consent is prohibited and any infringement will be subject to legal action.

© Little 2016

COMPTON
CCD

CAMPUS PUBLIC SAFETY BUILDING
1111 EAST ARTESIA BOULEVARD,
COMPTON CALIFORNIA 90221

IDENTIFICATION STAMP
DIV. OF THE STATE ARCHITECT
OFFICE OF REGULATION SERVICES

FILE NO: 19-C1
AR: 03-117673

AC: [Signature] RSK: [Signature] SS: [Signature] P2

DATE: DEC 12 2017

- LEGEND
- [Pattern] EXPOSED METAL DECK, SEE STRUCT.
 - [Pattern] 2'-0" x 2'-0" SUSPENDED ACoustICAL GRID PANELS PER ROOM FINISH SCHEDULE
 - [Pattern] * GYPSUM BOARD PER FINISH SCHEDULE. FOR MORE INFO, SEE DETAIL 6 & 7/A9.1.2
 - + X'-X" HEIGHT OF CEILING / SOFFIT
 - [Symbol] SWITCH, SEE ELECTRICAL
 - [Symbol] SMOKE DETECTOR, SEE FIRE ALARM DWGS.
 - [Symbol] FIRE HORN, SEE FIRE ALARM DWGS.
 - [Symbol] LIGHT FIXTURES SEE ELECTRICAL DWGS.
 - [Symbol] UNIT SKYLIGHT, SEE ELECTRICAL DWGS FOR TYPE.
 - [Symbol] SUPPLY AIR DIFFUSER
 - [Symbol] RETURN AIR DIFFUSER
 - [Symbol] EXHAUST AIR DIFFUSER

- GENERAL NOTES
1. CENTER SUSPENDED CEILING GRIDS EACH WAY WITHIN SPACE, UNLESS NOTED OTHERWISE
 2. CENTER MECHANICAL AIR GRILLES BETWEEN LIGHTS / WALLS IN GYPSUM BOARD CEILINGS AS SHOWN
 3. CENTER LIGHT FIXTURES WITHIN SPACES UNLESS NOTED OTHERWISE
 4. CEILING HEIGHT IS 9'-0" A.F.F. UNLESS NOTED OTHERWISE
 5. FOR ALL LOCATIONS OF N.I.C. LCD PROJECTORS, INSTALL OVERHEAD MOUNTED EQUIPMENT SUPPORT PER ELECTRICAL DWGS.
 6. FOR TYPICAL CEILING NOTES AND DETAILS, SEE SHEET A9.1.3
 7. ALL STEEL MEMBERS EXPOSED TO WEATHER AND EXTERIOR SHALL BE HOT DIP GALVANIZED
 8. FOR GYP. BD CEILING DET. SEE 5 & 7/A9.1.2

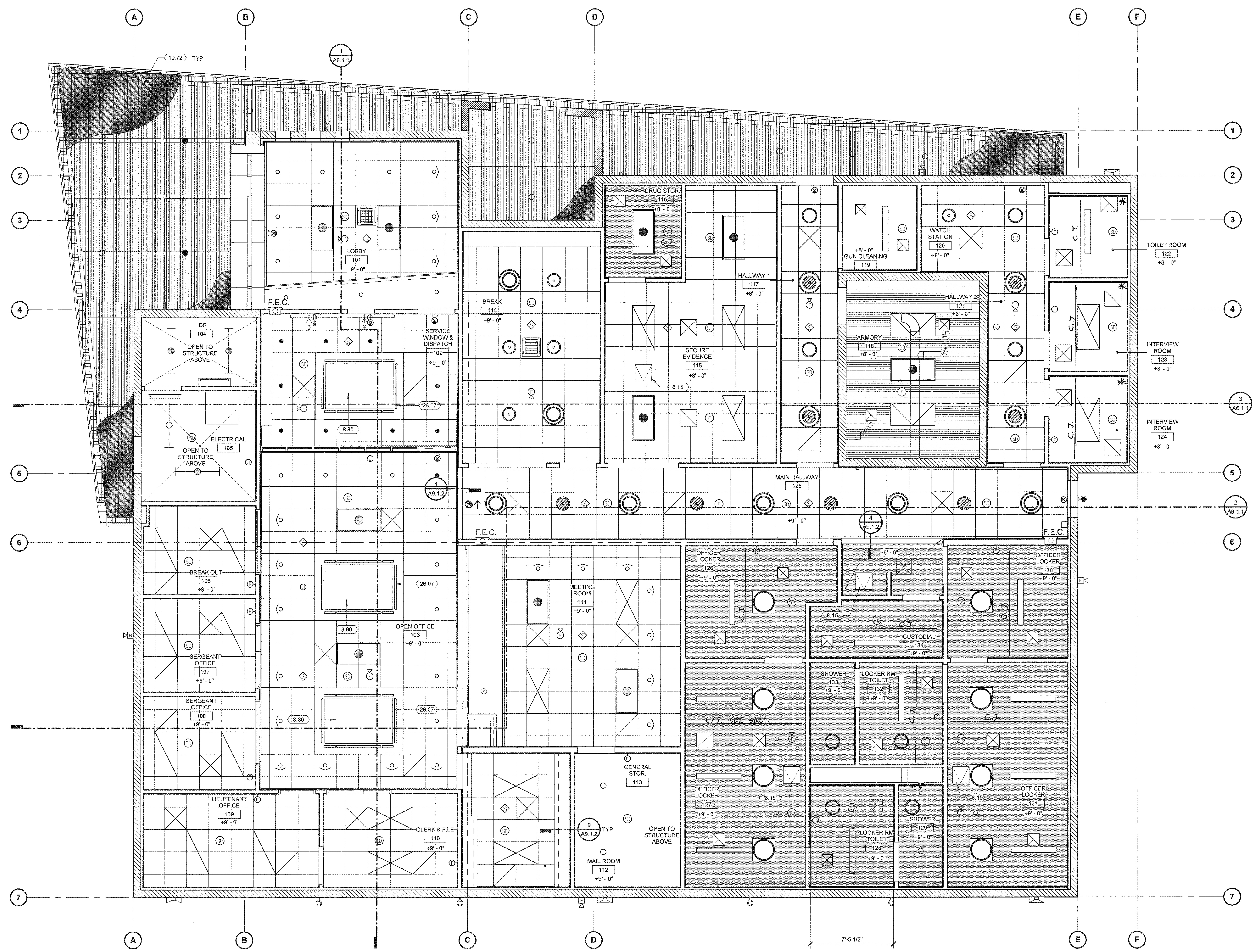

1 REFLECTED CEILING PLAN
1/4" = 1'-0"

PRINCIPAL IN CHARGE
RITA S. CARTER

PROJECT MANAGER
SHOJI TAKESHIMA / DAVID PHAN

DRAWN BY
DAVID PHAN

NO	REASON	DATE

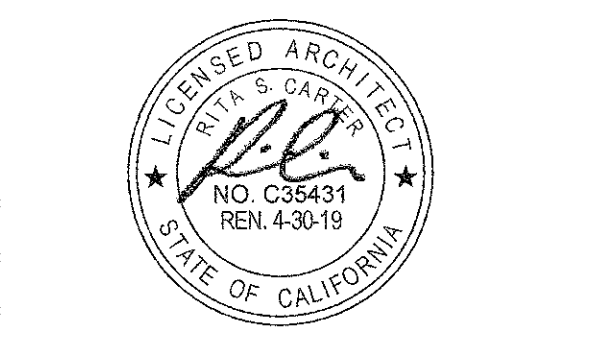

REFLECTED CEILING PLAN

PROJECT NUMBER
913-4675-00

DATE
12/01/16

SHEET NO.
A4.1.1

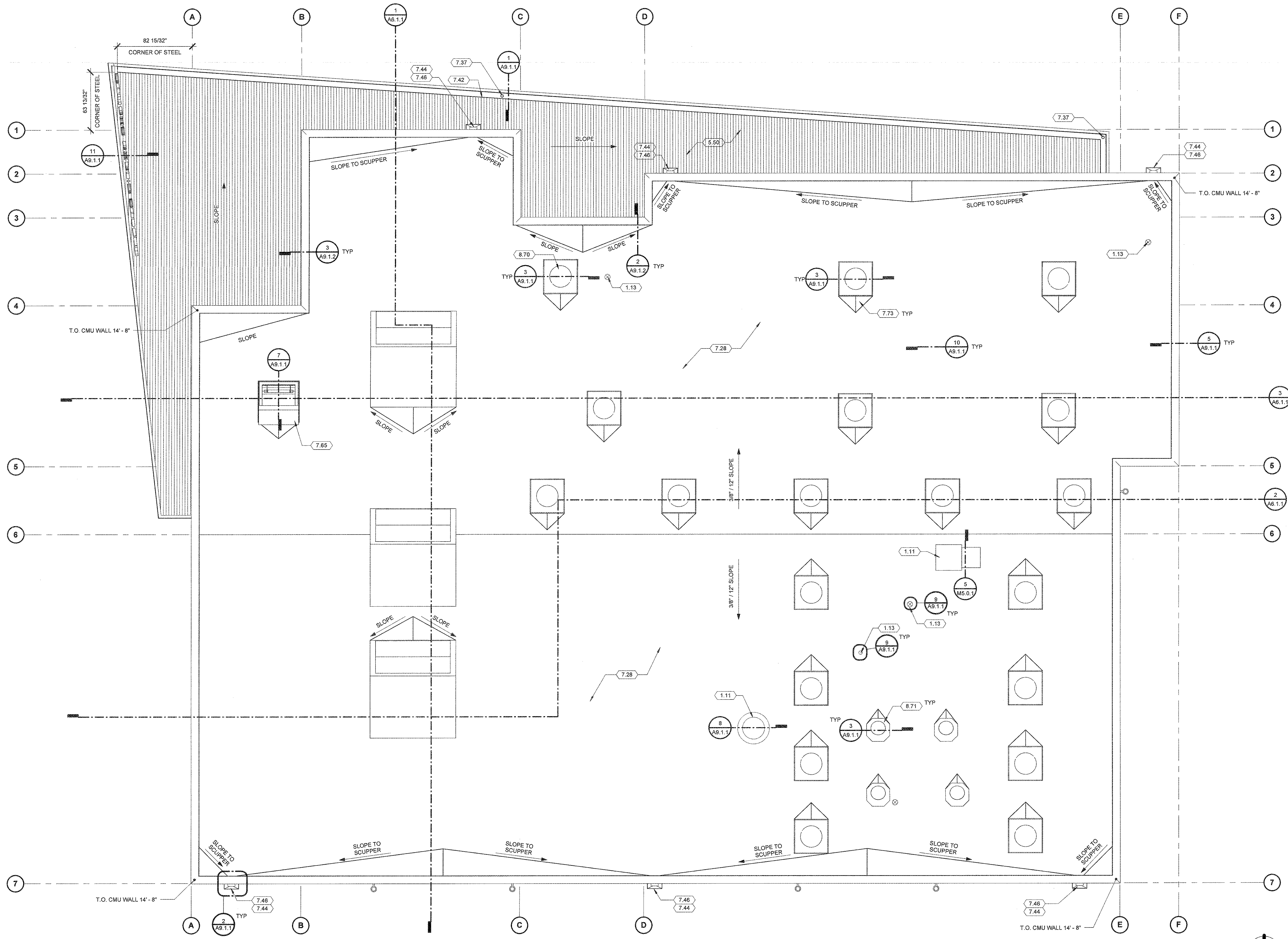

- KEYNOTES**
- 1.11 SEE MECHANICAL DRAWINGS
 - 1.13 SEE PLUMBING DRAWINGS
 - 5.50 METAL DECK PFX-1, PER STRUCTURAL - 05 31 00
 - 7.28 PVC SINGLE PLY MEMBRANE - 07 54 19
 - 7.37 METAL DOWNSPOUT - 07 60 00
 - 7.42 METAL GUTTER - 07 60 00
 - 7.44 METAL COLLECTOR BOX - 07 60 00
 - 7.46 OVERFLOW SCUPPER - 07 60 00
 - 7.65 ROOF ACCESS HATCH - 07 72 00
 - 7.73 CRICKET
 - 8.70 TUBULAR SKYLIGHT, TYPE 1 - 08 62 00
 - 8.71 TUBULAR SKYLIGHT, TYPE 2 - 08 62 00

LITTLE
DIVERSIFIED ARCHITECTURAL CONSULTING

1300 Dove Street, Suite 100
Newport Beach, CA 92660
T: 949.698.1400 F: 949.698.1433
www.littleonline.com

This drawing and the design shown are the property of Little Diversified Architectural Consulting. The reproduction, copying or other use of this drawing without their written consent is prohibited and any infringement will be subject to legal action.

© Little 2016

**COMPTON
CCD**

CAMPUS PUBLIC SAFETY BUILDING

1111 EAST ARTESIA BOULEVARD,
COMPTON CALIFORNIA 90221

IDENTIFICATION STAMP
DIV. OF THE STATE ARCHITECT
OFFICE OF REGULATION SERVICES

FILE NO: 19-C1
AF: 03-117673

DATE: DEC 17 2017

LEGEND

PRINCIPAL IN CHARGE
RITA S. CARTER

PROJECT MANAGER
SHOJI TAKESHIMA / DAVID PHAN

DRAWN BY
DAVID PHAN

GENERAL NOTES

1. FOR TYPICAL ROOF PENETRATIONS, SEE SHEET A9.1.1.
2. SEE MECHANICAL FOR TYPICAL DUCT SUPPORT
3. SEE STRUCTURAL FOR T.O. ROOF FRAMING.
4. SEE PLUMBING FOR VENT PENETRATIONS.

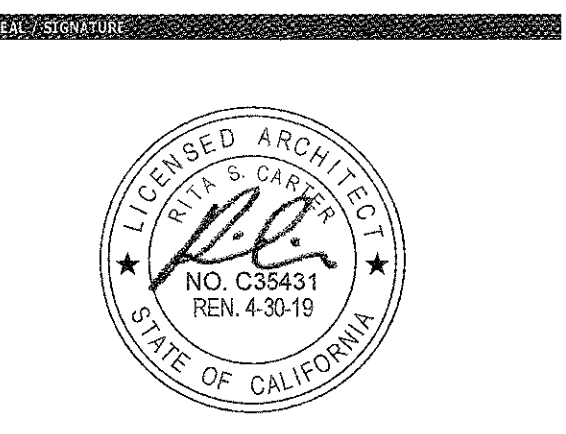

ROOF PLAN

PROJECT NUMBER
913-4675-00

DATE
12/01/16

REV. NO.
A5.0.1

1 ROOF PLAN
A5.0.1 1/4" = 1'-0"

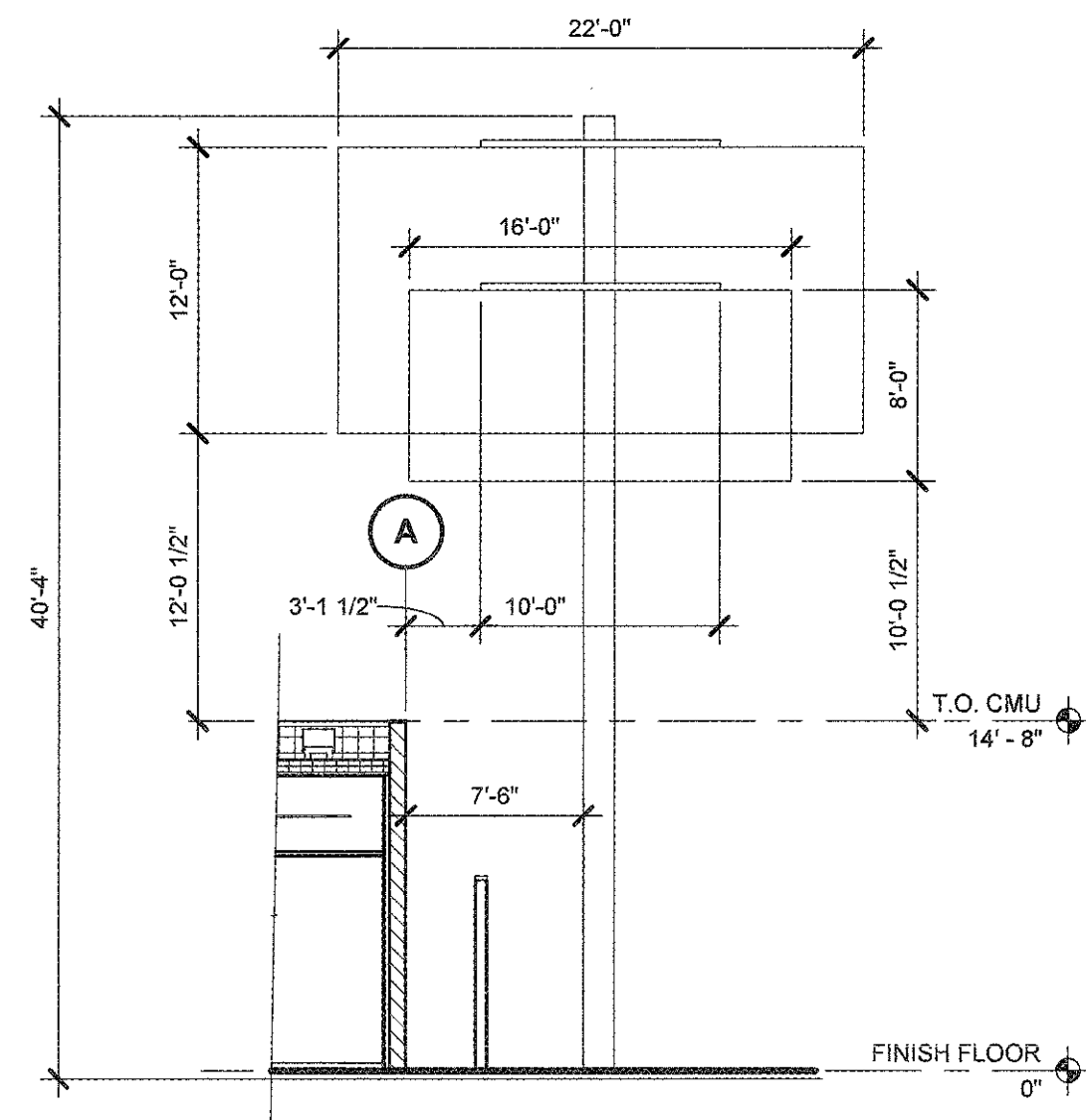

5 SCE POLE CLEARANCE
A6.0.1 1/8" = 1'-0"

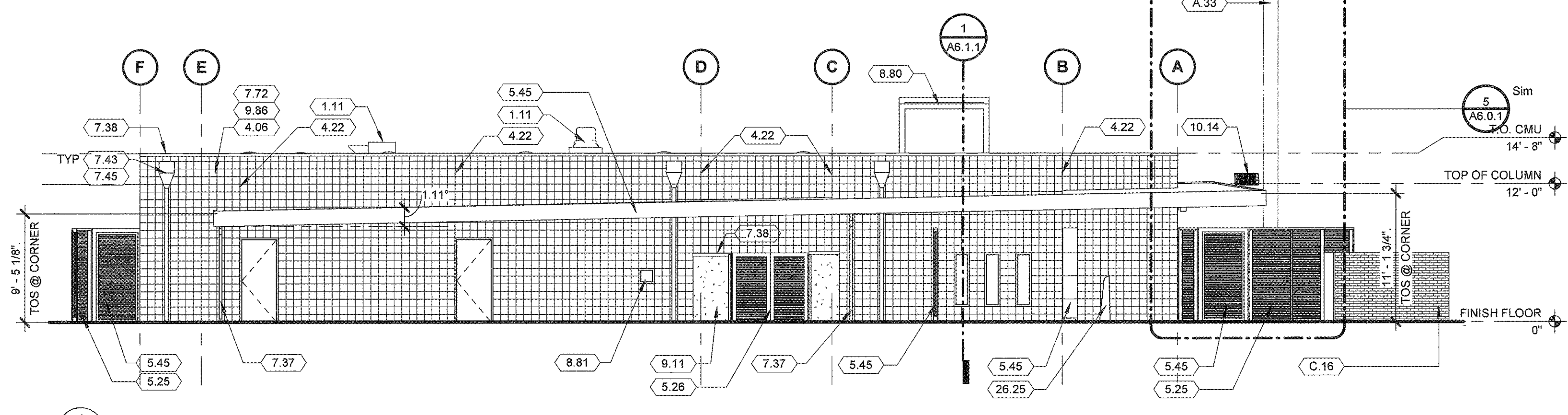

1 EXTERIOR ELEVATION - SOUTH
A6.0.1 1/8" = 1'-0"

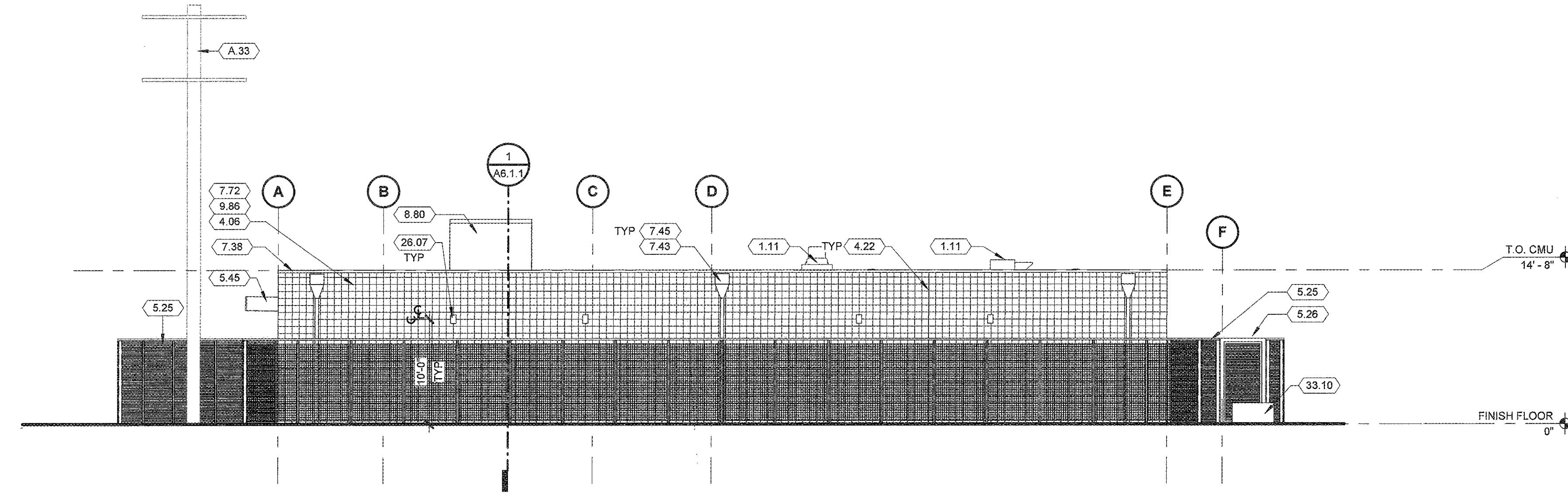

2 EXTERIOR ELEVATION - NORTH
A6.0.1 1/8" = 1'-0"

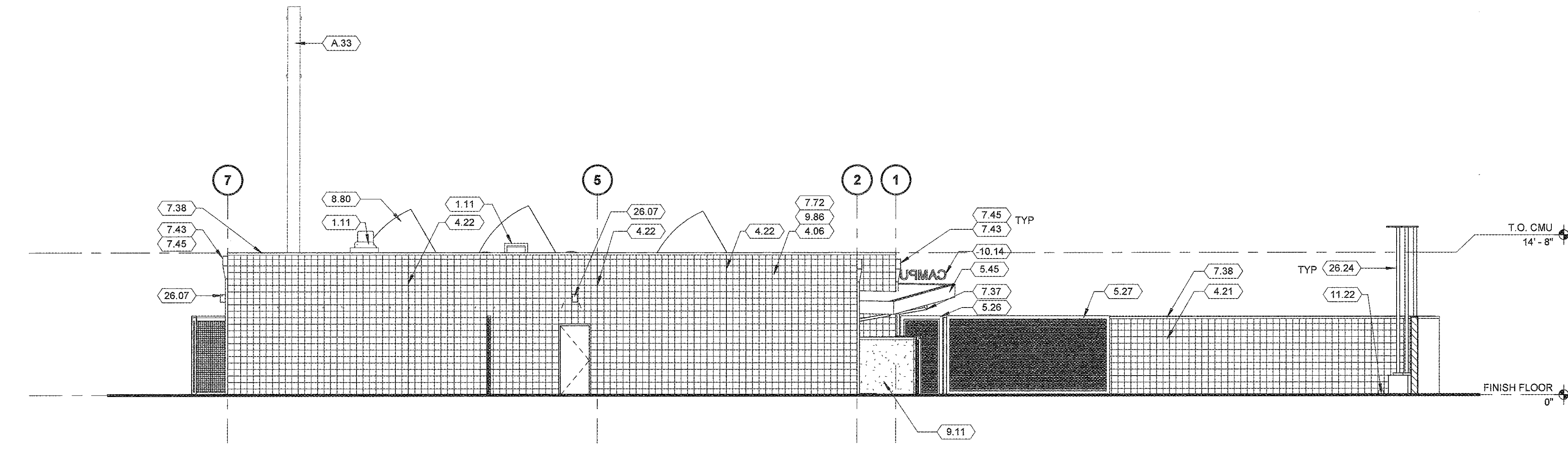

3 EXTERIOR ELEVATION - EAST
A6.0.1 1/8" = 1'-0"

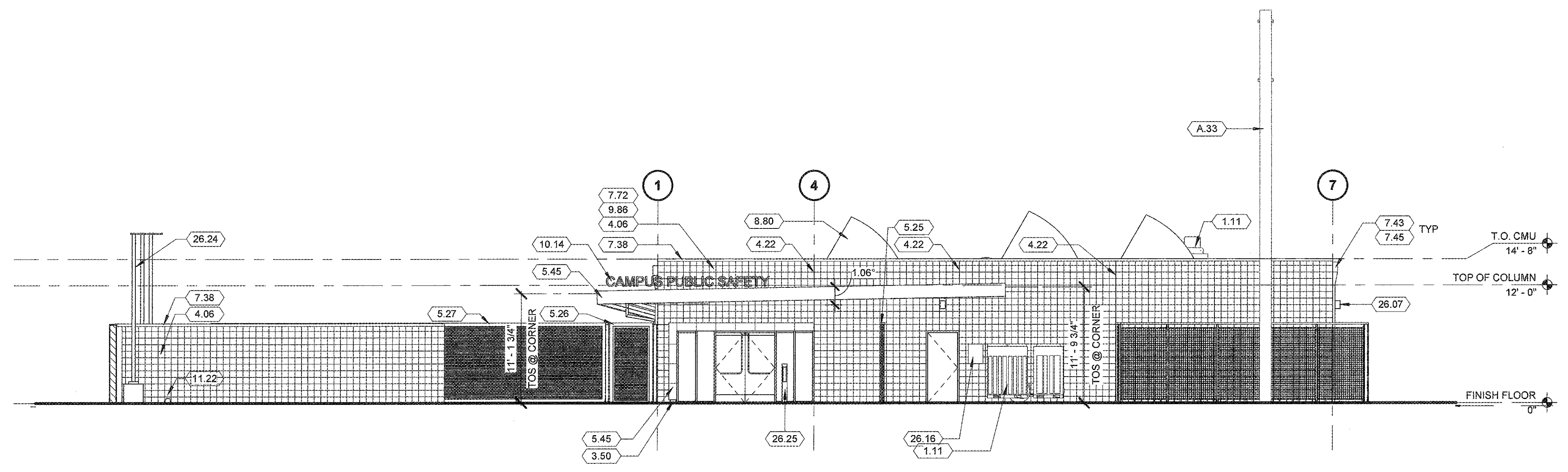

4 EXTERIOR ELEVATION - WEST
A6.0.1 1/8" = 1'-0"

- KEYNOTES**
- 1.11 SEE MECHANICAL DRAWINGS
 - 3.50 EXPOSED CAST-IN-PLACE CONCRETE - 32 30 00
 - 4.06 CONCRETE MASONRY UNIT CMU - 04 22 00
 - 4.21 CONCRETE MASONRY UNIT SITE WALL PER 9/55/2 & METAL COPING CAP PER DETAIL 5/A9.1.1 - 04 22 00
 - 4.22 CONCRETE MASONRY CONTROL JOINT, SEE DET. 2/55.1
 - 5.25 FABRICATED STEEL FENCE - 32 13 17
 - 5.26 FABRICATED STEEL GATE - 32 13 17
 - 5.27 FABRICATED STEEL ROLLING GATE, SEE SHEET A1.3.3 - 05 50 00
 - 5.45 COMPOSITE METAL PANEL SYSTEM - 07 42 13
 - 7.37 METAL DOWNSPOUT - 07 60 00
 - 7.38 METAL COPING - 07 60 00
 - 7.43 METAL LEADER & DOWNSPOUT - 07 60 00
 - 7.45 METAL SCUPPER - 07 60 00
 - 7.72 WATER REPELLENT - 07 19 00
 - 8.80 CLERESTORY WINDOW
 - 8.81 STEEL PASS-THROUGH EVIDENCE DROP-OFF, SEE DETAIL /
 - 9.11 PORTLAND CEMENT PLASTER - 09 20 00
 - 9.86 GRAFFITI RESISTANT COATING - 09 96 23
 - 10.14 SIGNAGE - 10 14 00
 - 11.22 PARKING WHEEL STOP, SEE DET. 6/A1.3.1 - 32 17 13
 - 26.07 LIGHT FIXTURE, SEE ELECTRICAL
 - 26.16 IRRIGATION CONTROL PANEL, PER LANDSCAPING & ELECTRICAL
 - 26.24 SITE POLE LIGHTING & CONCRETE BASE PER 7/E0.0.6, TYP., SEE ELECTRICAL
 - 26.25 O.I.C.F. SITE POLE LIGHTING & CONCRETE BASE PER 7/E0.0.6, TYP., SEE ELECTRICAL
 - 33.10 BACKFLOW PREVENTER & ENCLOSURE, PER CIVIL
 - A.33 (E) UTILITY COMPANY POWER POLE AND BRACE TO REMAIN, PROTECT IN PLACE.
 - C.16 EXISTING BRICK VENEER WALL & ASSOCIATED GATES TO REMAIN, PROTECT IN PLACE

LITTLE
DIVERSIFIED ARCHITECTURAL CONSULTING

1300 Dove Street, Suite 100
Newport Beach, CA 92660
T: 949.698.1400 F: 949.698.1433

www.littleonline.com

This drawing and the design shown are the property of Little Diversified Architectural Consulting. The reproduction, copying or other use of this drawing without their written consent is prohibited and any infringement will be subject to legal action.

© Little 2016

**COMPTON
CCD**

CAMPUS PUBLIC SAFETY BUILDING

1111 EAST ARTESIA BOULEVARD,
COMPTON CALIFORNIA 90221

IDENTIFICATION STAMP
DIV. OF THE STATE ARCHITECT
OFFICE OF REGULATION SERVICES

FILE NO. 19-C1
AR: 03-117673

AC: [Signature] RJS
DATE: DEC. 1 2 2017

CONTRACTOR

PRINCIPAL IN CHARGE
RITA S. CARTER

PROJECT MANAGER
SHOJI TAKESHIMA / DAVID PHAN

DRAWN BY
DAVID PHAN

NO	REASON	DATE

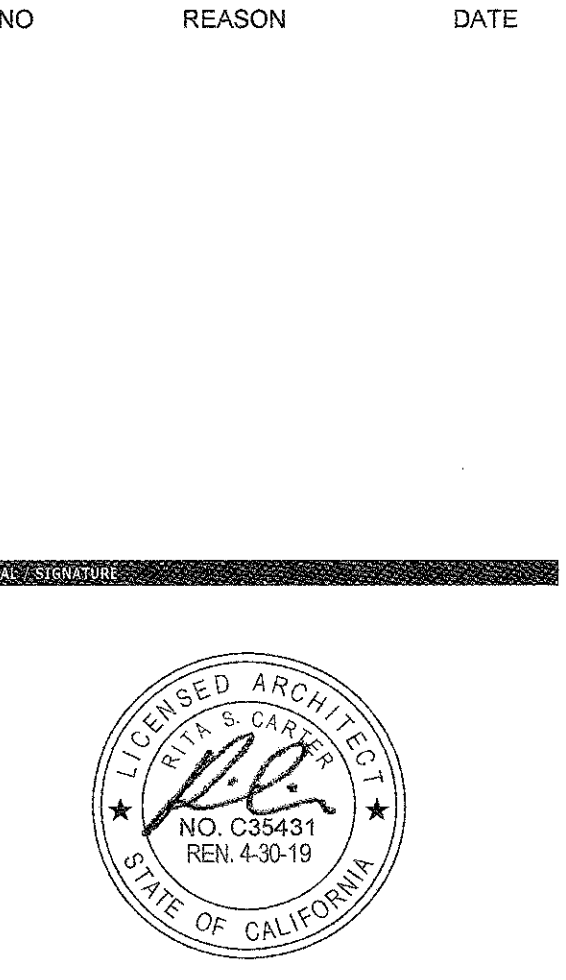

LEGEND

[Grid Pattern] CONCRETE MASONRY UNIT

GENERAL NOTES

- FIRST FLOOR FINISH FLOOR FOR BUILDING 'A' IS 0'-0" = 58.67"
- ALL STEEL MEMBERS EXPOSED TO WEATHER AND EXTERIOR SHALL BE HOT DIP GALVANIZED

PROJECT NUMBER
913-4675-00

DATE
12/01/16

SHEET NO.
A6.0.1

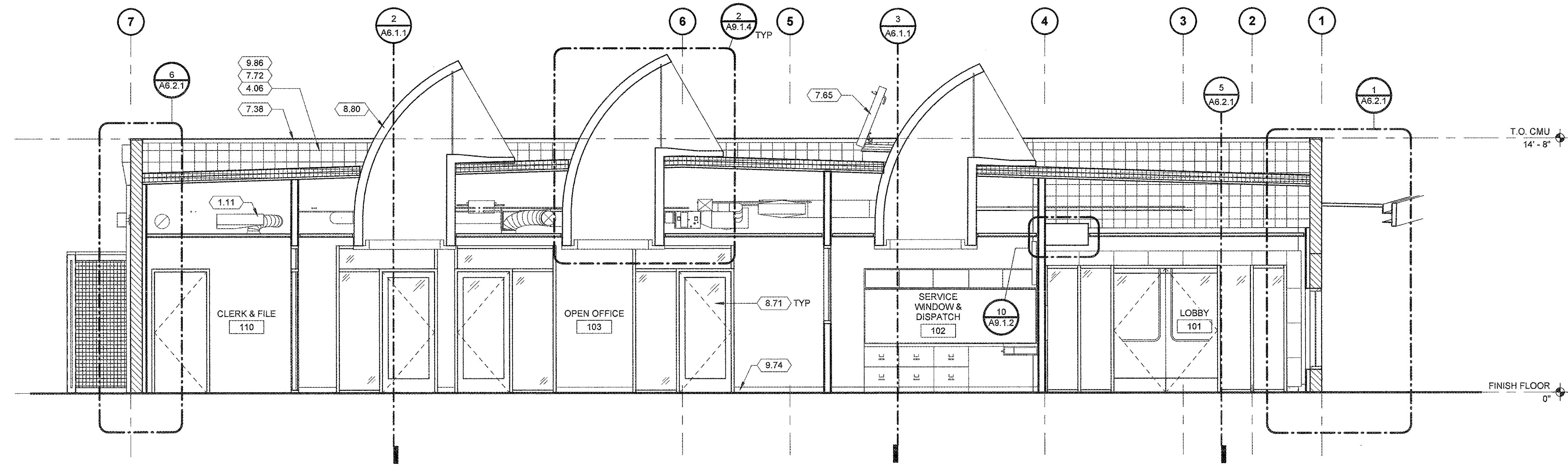

1 SECTION 1
A6.1.1 1/4" = 1'-0"

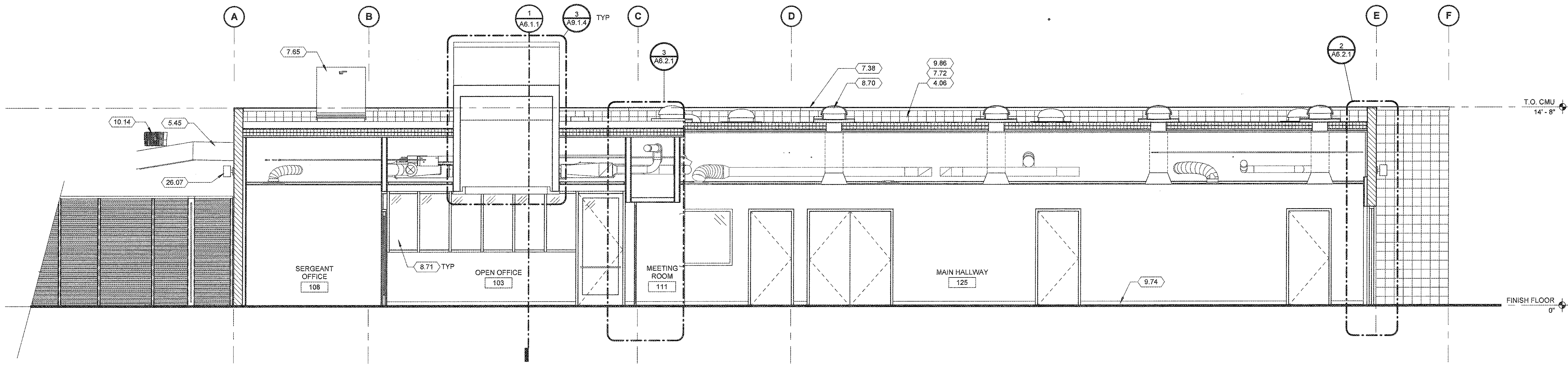

2 SECTION 2
A6.1.1 1/4" = 1'-0"

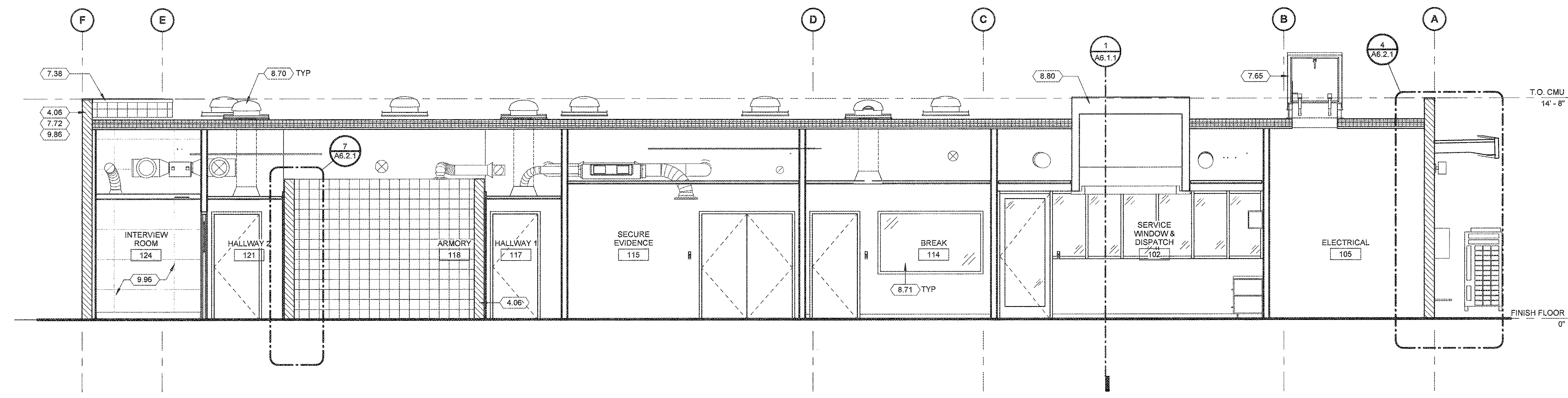

3 SECTION 3
A6.1.1 1/4" = 1'-0"

- KEYNOTES
- 1.11 SEE MECHANICAL DRAWINGS
 - 4.06 CONCRETE MASONRY UNIT CMU - 04 22 00
 - 5.45 COMPOSITE METAL PANEL SYSTEM - 07 42 13
 - 7.38 METAL COPING - 07 60 00
 - 7.65 ROOF ACCESS HATCH - 07 72 00
 - 7.72 WATER REPELLENT - 07 19 00
 - 8.70 TUBULAR SKYLIGHT, TYPE 1 - 08 62 00
 - 8.71 TUBULAR SKYLIGHT, TYPE 2 - 08 62 00
 - 8.80 CLERESTORY WINDOW
 - 9.74 WALL BASE, SEE FINISH SCHEDULE - 09 65 00
 - 9.86 GRAFFITI RESISTANT COATING - 09 96 23
 - 9.96 RIGID PROTECTIVE WALL COVERING - 09 72 17
 - 10.14 SIGNAGE - 10 14 00
 - 26.07 LIGHT FIXTURE, SEE ELECTRICAL

LITTLE
DIVERSIFIED ARCHITECTURAL CONSULTING

1300 Dove Street, Suite 100
Newport Beach, CA 92660
T: 949.698.1400 F: 949.698.1433
www.littleonline.com

This drawing and the design shown are the property of Little Diversified Architectural Consulting. The reproduction, copying or other use of this drawing without their written consent is prohibited and any infringement will be subject to legal action.

© Little 2016

CLIENT NAME
**COMPTON
CCD**

PROJECT NAME
CAMPUS PUBLIC SAFETY BUILDING

1111 EAST ARTESIA BOULEVARD,
COMPTON CALIFORNIA 90221

IDENTIFICATION STAMP
DIV. OF THE STATE ARCHITECT
OFFICE OF REGULATION SERVICES

FILE NO: 19-C1
AR: 03-117673

AC: [Signature] FLS: [Signature] SS: [Signature]
DATE: DEC. 12 2017

DESIGNER
PRINCIPAL IN CHARGE
RITA S. CARTER

PROJECT MANAGER
SHOJI TAKESHIMA / DAVID PHAN

DRAWN BY
DAVID PHAN

REVISIONS

NO	REASON	DATE

SCALE/SIGNATURE



GENERAL NOTES

1. ALL STEEL MEMBERS EXPOSED TO WEATHER AND EXTERIOR SHALL BE HOT DIP GALVANIZED

SHEET TITLE
BUILDING SECTIONS

PROJECT NUMBER
913-4675-00

SHEET DATE / SHEET NO.
12/01/16 / **A6.1.1**

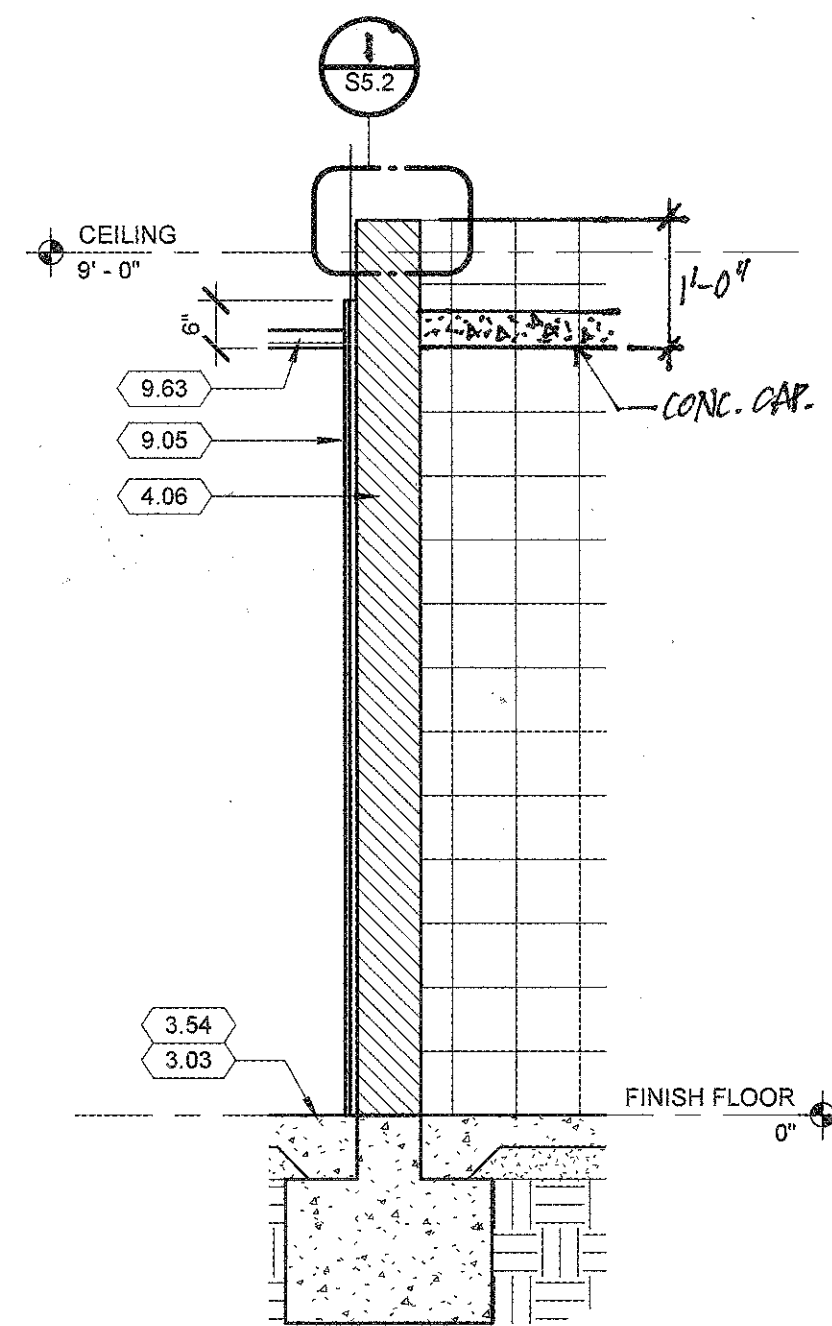

7 ARMORY TYP. WALL SECTION
A6.2.1 1/2" = 1'-0"

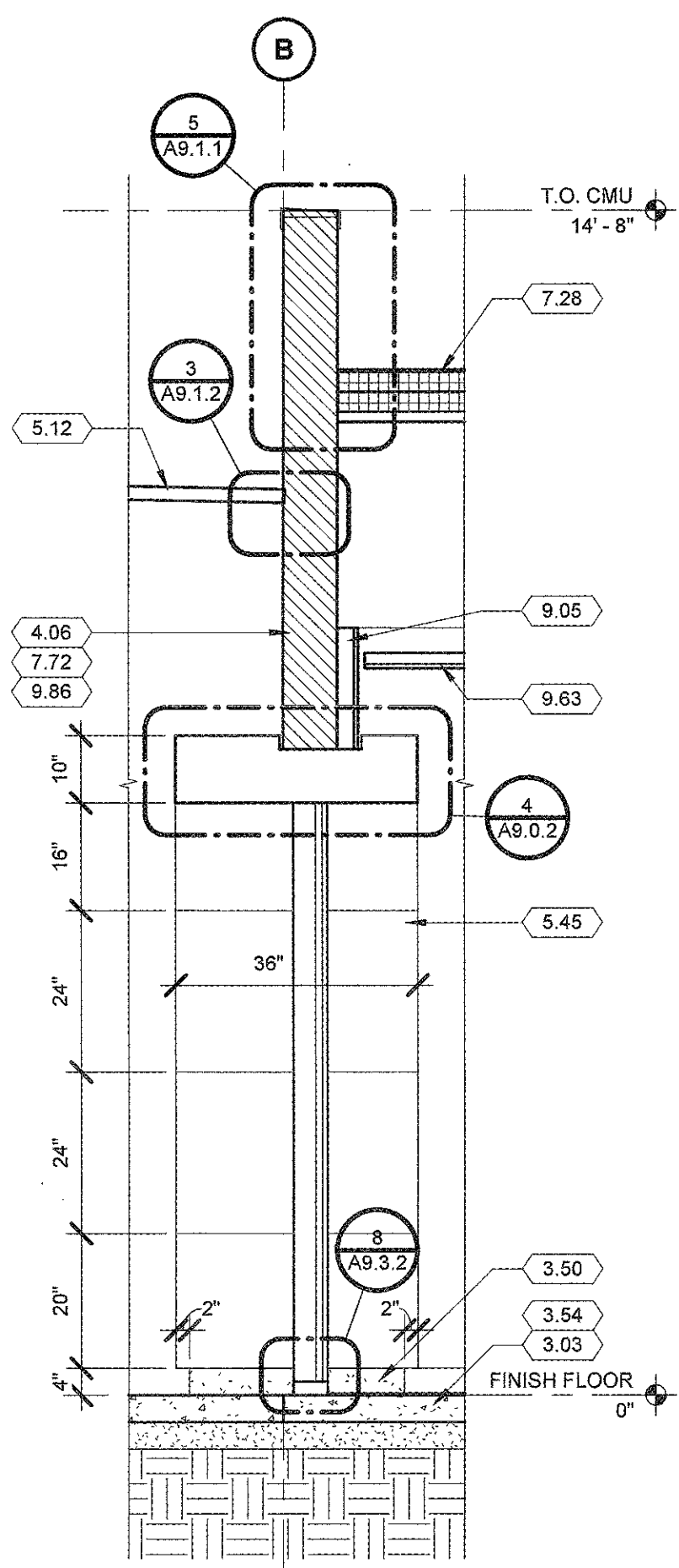

5 ENTRY
A6.2.1 1/2" = 1'-0"

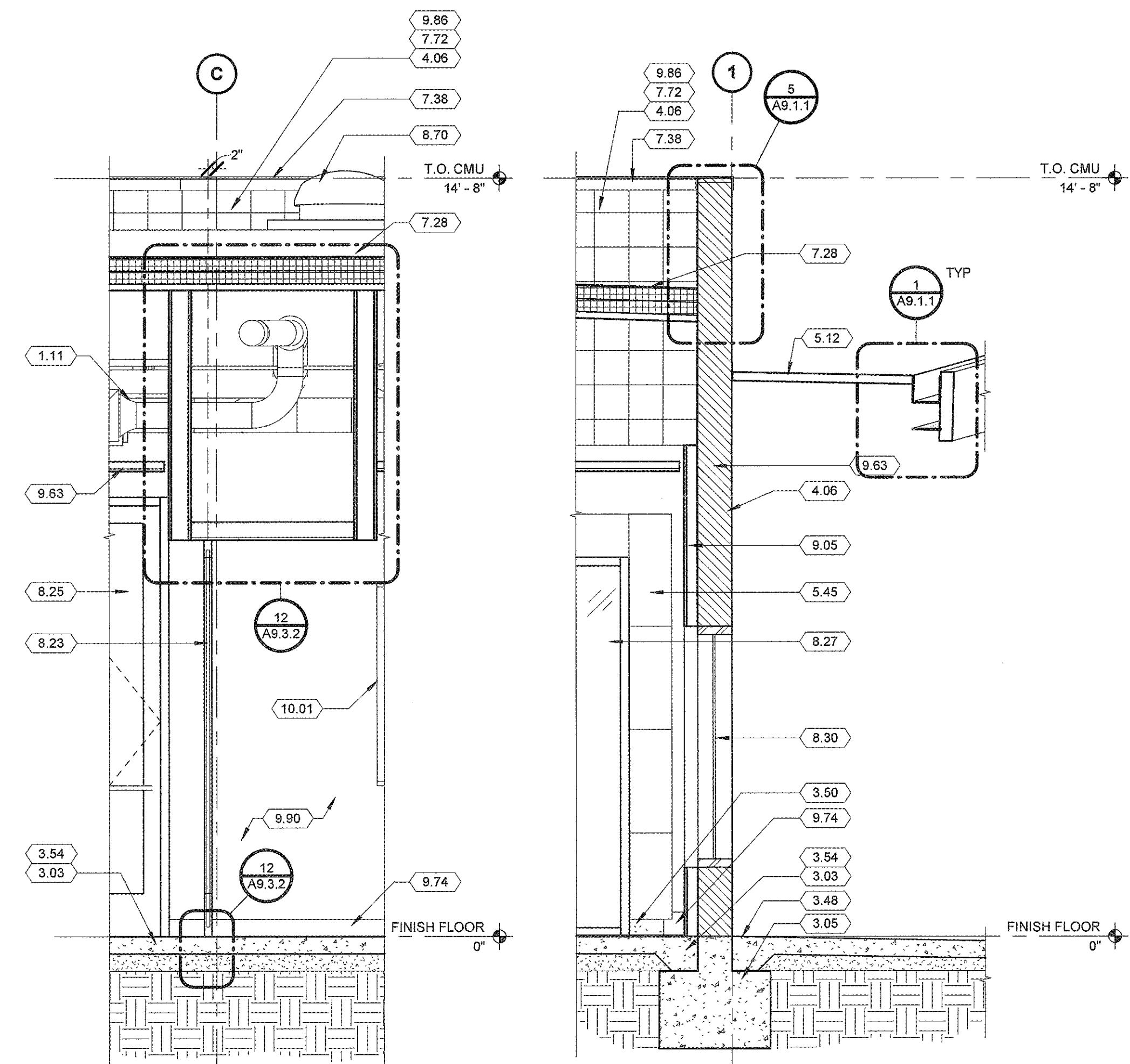

3 MEETING RM SLIDING DOORS
A6.2.1 1/2" = 1'-0"

1 WALL SECTION 1
A6.2.1 1/2" = 1'-0"

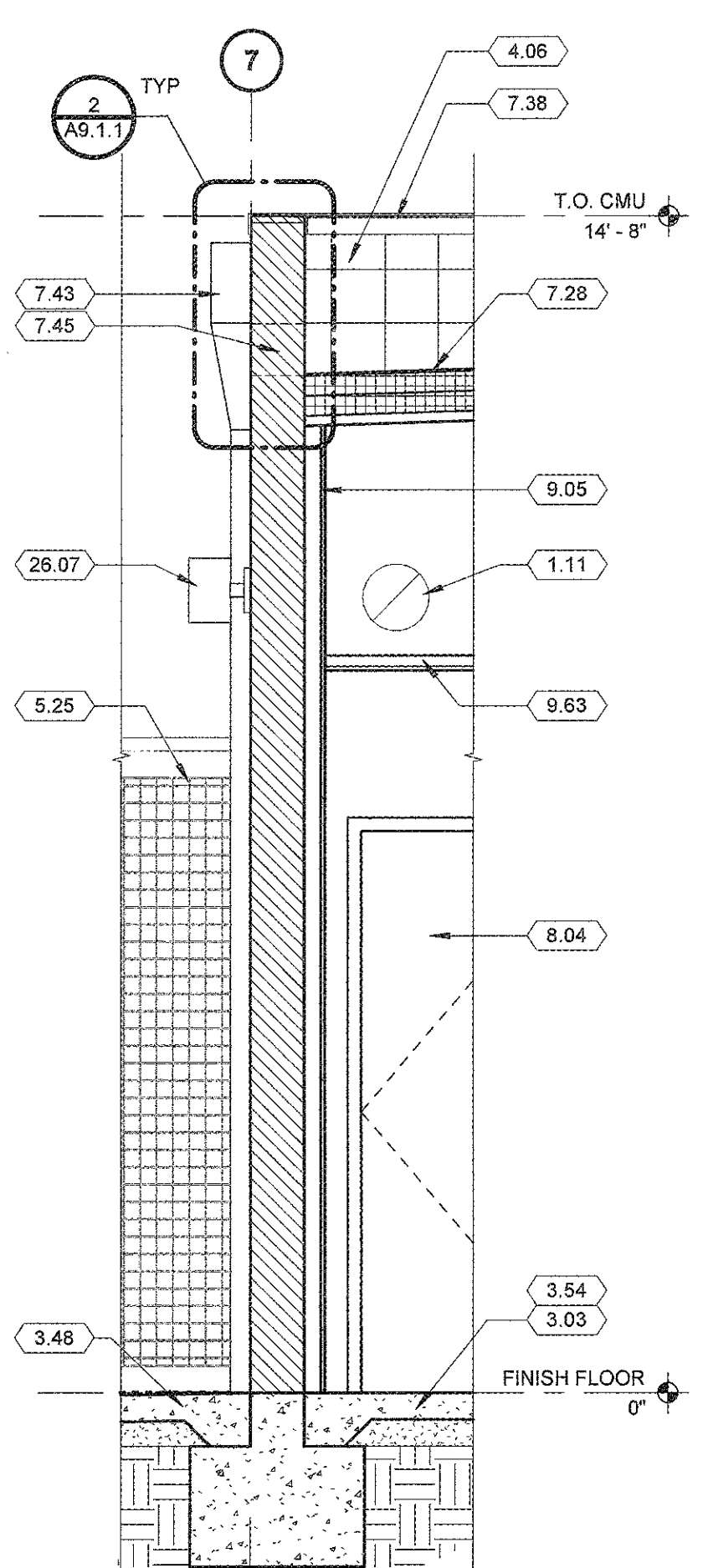

6 TYP. DOWNSPOUT @ WALL
A6.2.1 1/2" = 1'-0"

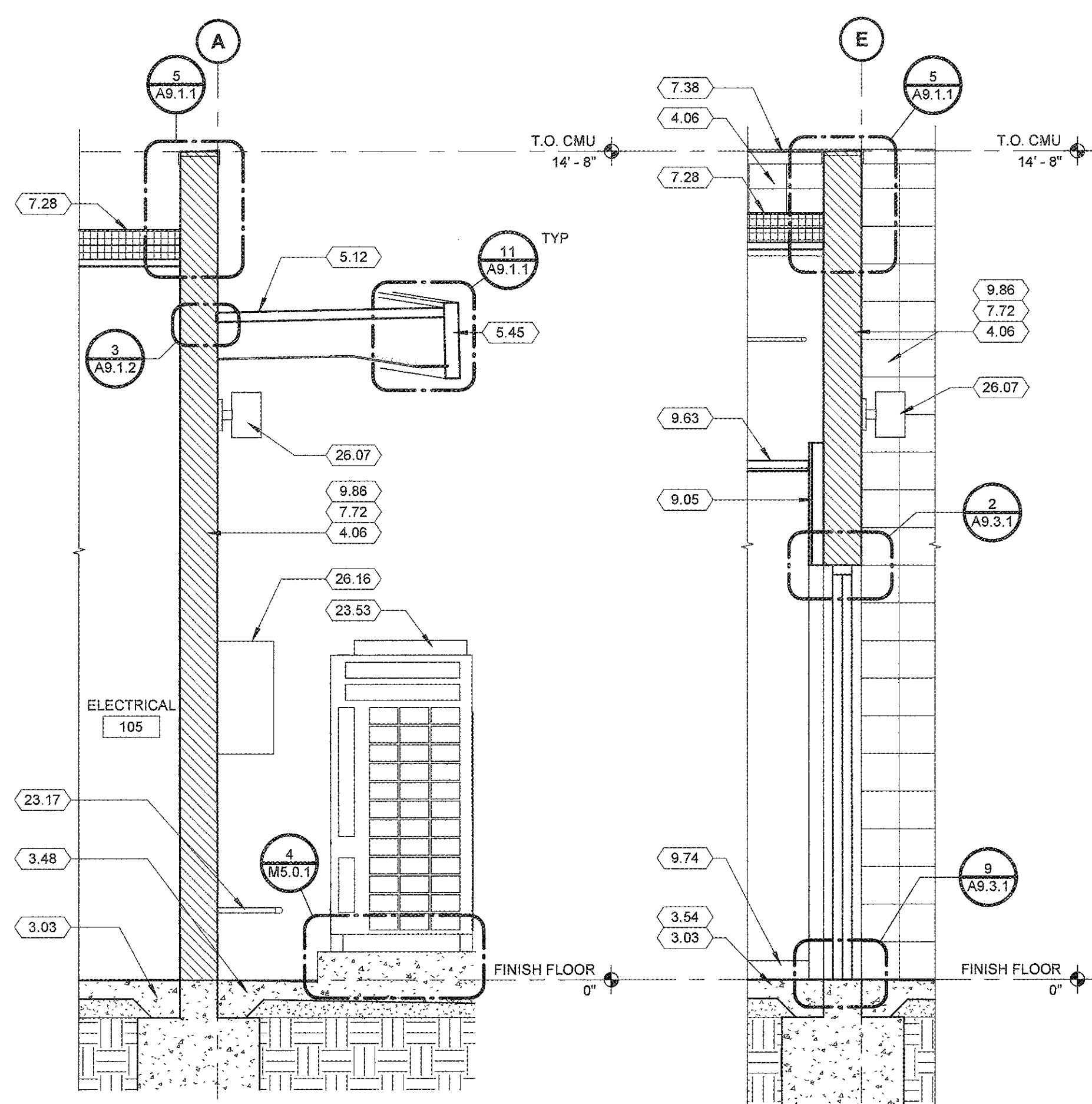

4 TYP. CANOPY @ WALL
A6.2.1 1/2" = 1'-0"

2 TYP EXT. DOOR
A6.2.1 1/2" = 1'-0"

- KEYNOTES**
- 1.11 SEE MECHANICAL DRAWINGS
 - 3.03 CAST-IN-PLACE CONCRETE SLAB, SEE STRUCTURAL - 03 30 10
 - 3.05 CAST-IN-PLACE CONCRETE FOOTING, SEE STRUCTURAL - 03 30 10
 - 3.48 CONCRETE SIDEWALK/PAVEMENT, SEE CIVIL
 - 3.50 EXPOSED CAST-IN-PLACE CONCRETE - 32 30 00
 - 3.54 POLISHED CONCRETE FINISH - 03 35 10
 - 4.06 CONCRETE MASONRY UNIT CMU - 04 22 00
 - 5.01 STEEL BEAM, PER STRUCTURAL - 05 12 00
 - 5.12 STEEL DECKING, PER STRUCTURAL
 - 5.25 FABRICATED STEEL FENCE - 32 13 17
 - 5.45 COMPOSITE METAL PANEL SYSTEM - 07 42 13
 - 5.51 HOT DIP GALVANIZED CANOPY STRUCTURAL FRAMING, PER STRUCTURAL - 05 12 00
 - 7.28 PVC SINGLE PLY MEMBRANE - 07 54 19
 - 7.38 METAL COPING - 07 60 00
 - 7.43 METAL LEADER & DOWNSPOUT - 07 60 00
 - 7.45 METAL SCUPPER - 07 60 00
 - 7.72 WATER REPELLENT - 07 19 00
 - 8.04 HOLLOW METAL DOOR - 08 11 00
 - 8.23 GLASS PANEL DOORS - 08 35 14
 - 8.25 ALUMINUM STOREFRONT DOOR - 08 41 00
 - 8.27 ALUMINUM STOREFRONT SYSTEM - 08 41 00
 - 8.30 HOLLOW METAL WINDOW, SEE ELEVATIONS - 08 51 23
 - 8.70 TUBULAR SKYLIGHT, TYPE 1 - 08 62 00
 - 9.05 METAL STUD FURRING
 - 9.63 SUSPENDED ACOUSTICAL CEILING (ACP-1) - 09 51 00
 - 9.74 WALL BASE, SEE FINISH SCHEDULE - 09 65 00
 - 9.86 GRAFFITI RESISTANT COATING - 09 96 23
 - 9.90 PAINT FINISH - INTERIOR, SEE FINISH SCHEDULE - 09 91 00
 - 10.01 NON-GLARE, PROJECTABLE MARKERBOARD WALL COVERING - 10 11 16
 - 23.17 REFRIGERANT PIPING, PER MECHANICAL
 - 23.53 HVAC CONDENSING UNIT, PER MECHANICAL - 23 65 00
 - 26.07 LIGHT FIXTURE, SEE ELECTRICAL
 - 26.16 IRRIGATION CONTROL PANEL, PER LANDSCAPING & ELECTRICAL

- GENERAL NOTES**
1. ALL STEEL MEMBERS EXPOSED TO WEATHER AND EXTERIOR SHALL BE HOT DIP GALVANIZED
 2. FOR FOOTINGS, SEE STRUCTURAL FOUNDATION PLAN 1/S2.1

LITTLE
DIVERSIFIED ARCHITECTURAL CONSULTING

1300 Dove Street, Suite 100
Newport Beach, CA 92660
T: 949.698.1400 F: 949.698.1433
www.littleonline.com

This drawing and the design shown are the property of Little Diversified Architectural Consulting. The reproduction, copying or other use of this drawing without their written consent is prohibited and any infringement will be subject to legal action.

© Little 2016

**COMPTON
CCD**

CAMPUS PUBLIC SAFETY BUILDING

1111 EAST ARTESIA BOULEVARD,
COMPTON CALIFORNIA 90221

IDENTIFICATION STAMP
DIV. OF THE STATE ARCHITECT
OFFICE OF REGULATION SERVICES

FILE NO: 19-C1
AR: 03-117673

DATE: DEC 12 2017

PRINCIPAL IN CHARGE
RITA S. CARTER

PROJECT MANAGER
SHOJI TAKESHIMA / DAVID PHAN

DRAWN BY
DAVID PHAN

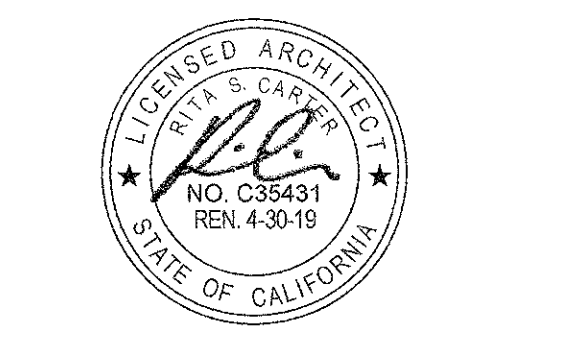

WALL SECTIONS

PROJECT NUMBER
913-4675-00

DATE PLOT: 12/01/16
SHEET NO: **A6.2.1**

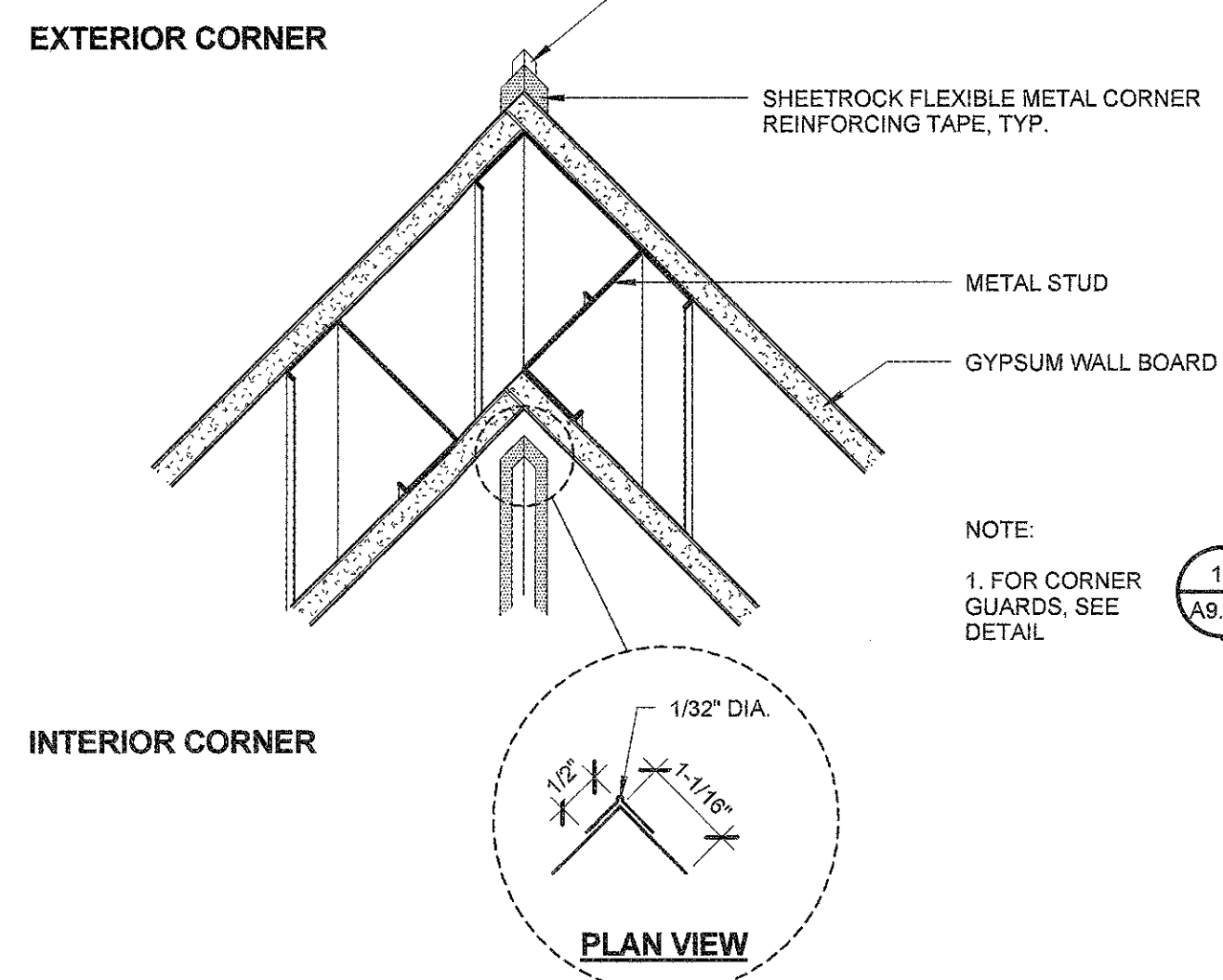

9 TYP. DRYWALL CORNER
A9.0.1 3" = 1'-0"

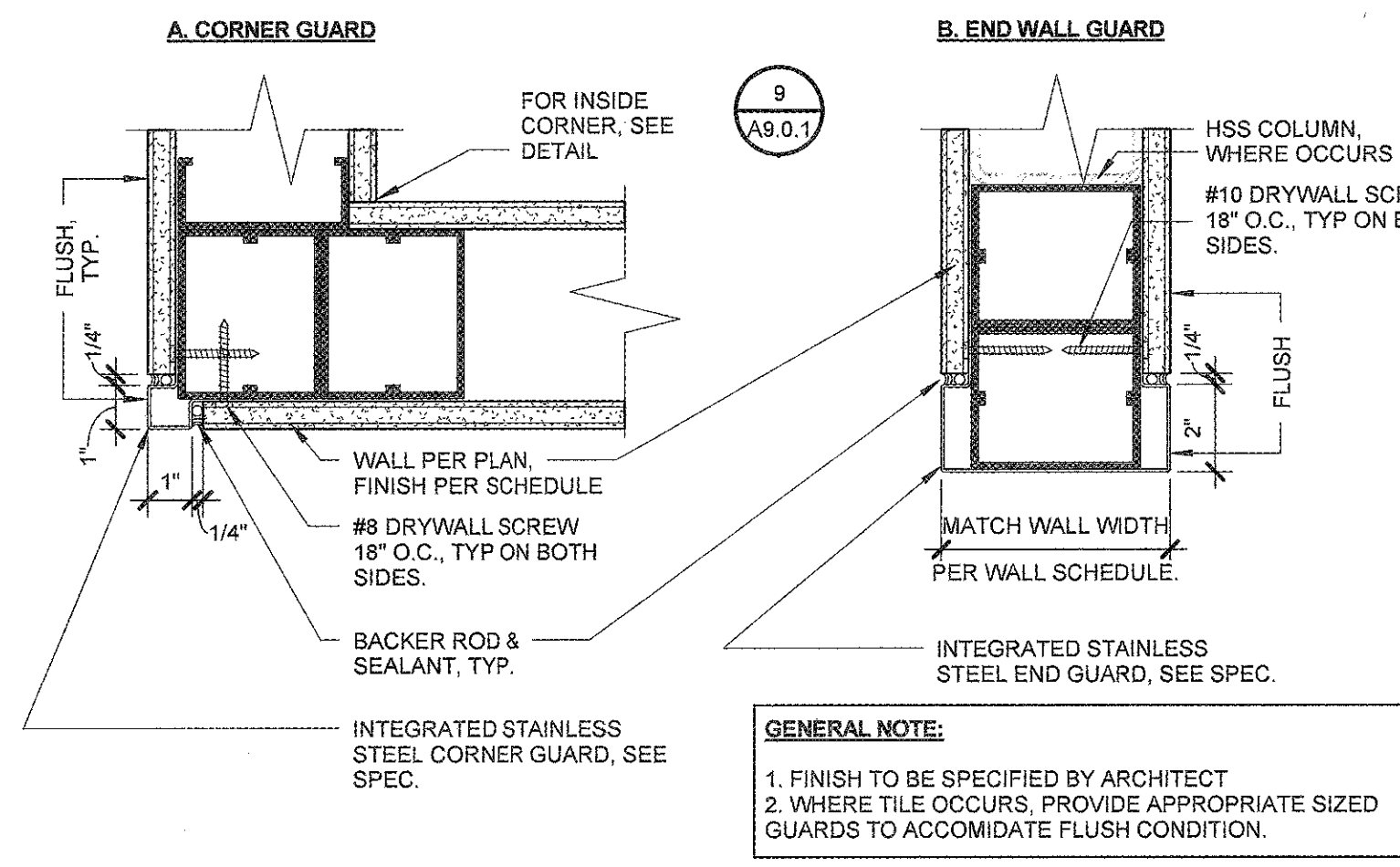

10 INTEGRATED CORNER & END WALL GUARDS
A9.0.1 3" = 1'-0"

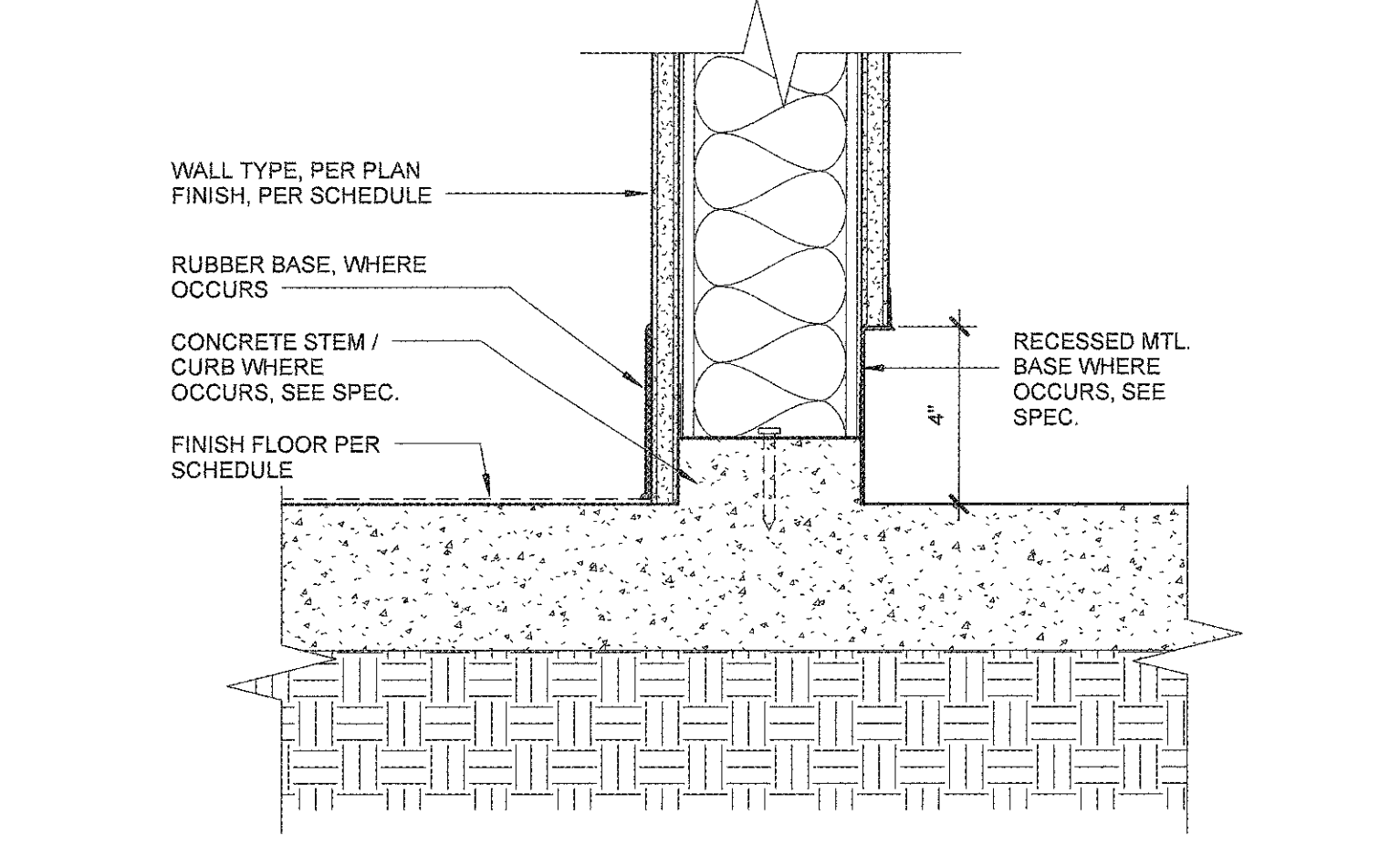

11 TYP. RUBBER & RECESSED MTL. BASE DETAIL
A9.0.1 3" = 1'-0"

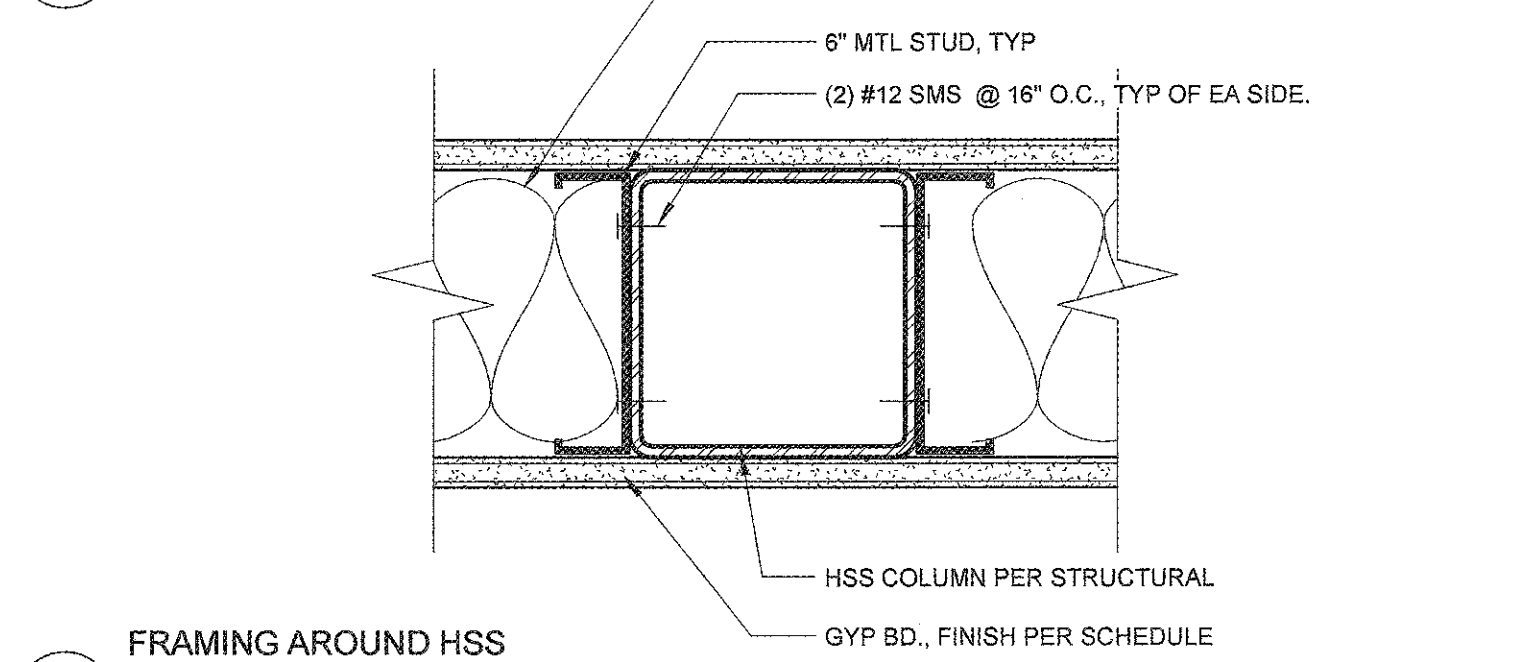

12 FRAMING AROUND HSS COLUMN
A9.0.1 3" = 1'-0"

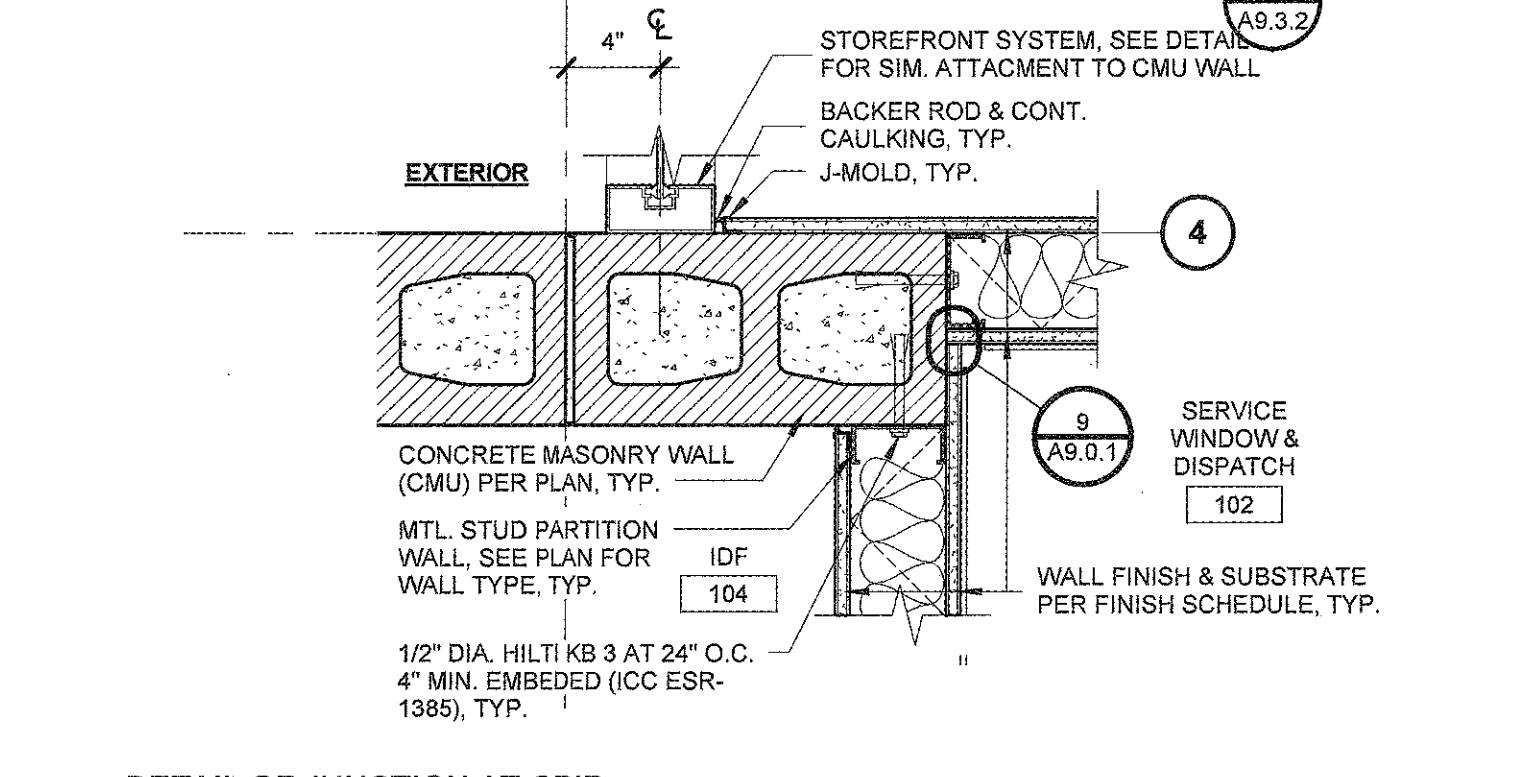

13 DETAIL OF JUNCTION AT GRID LINE B & 4
A9.0.1 1 1/2" = 1'-0"

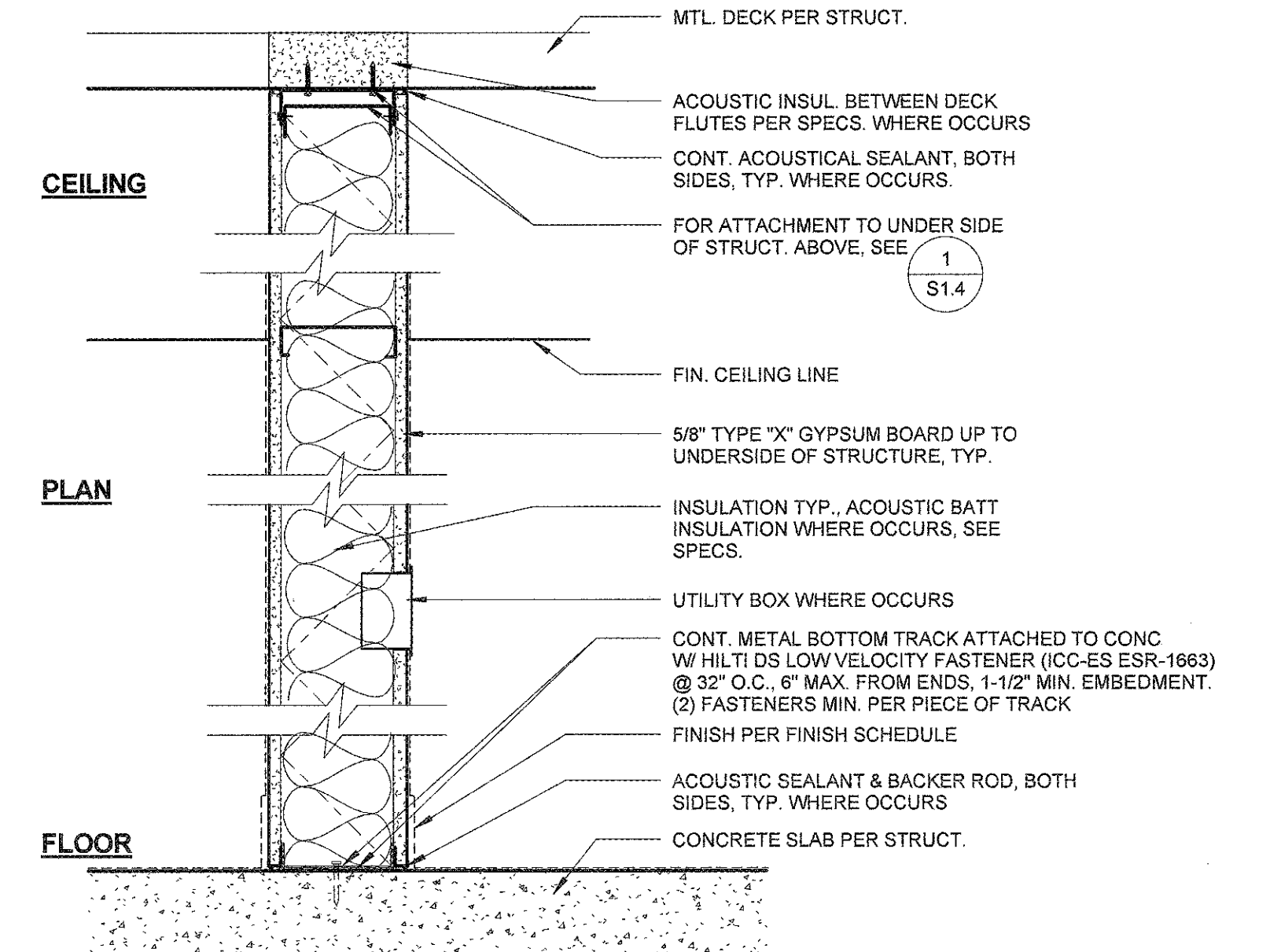

5 TYP. MTL STUD WALL
A9.0.1 1 1/2" = 1'-0"

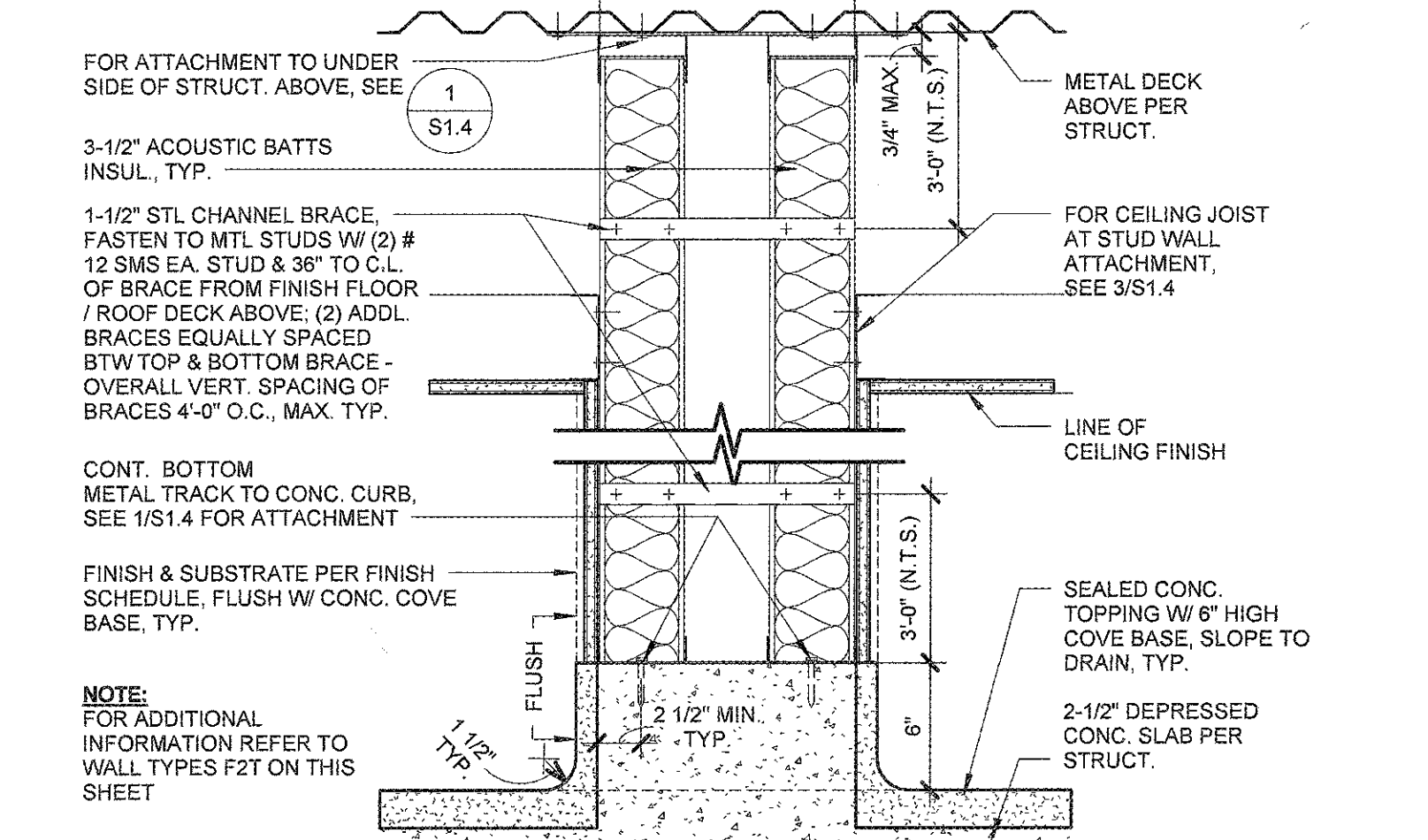

6 TYP. PLUMBING PARTITION
A9.0.1 1 1/2" = 1'-0"

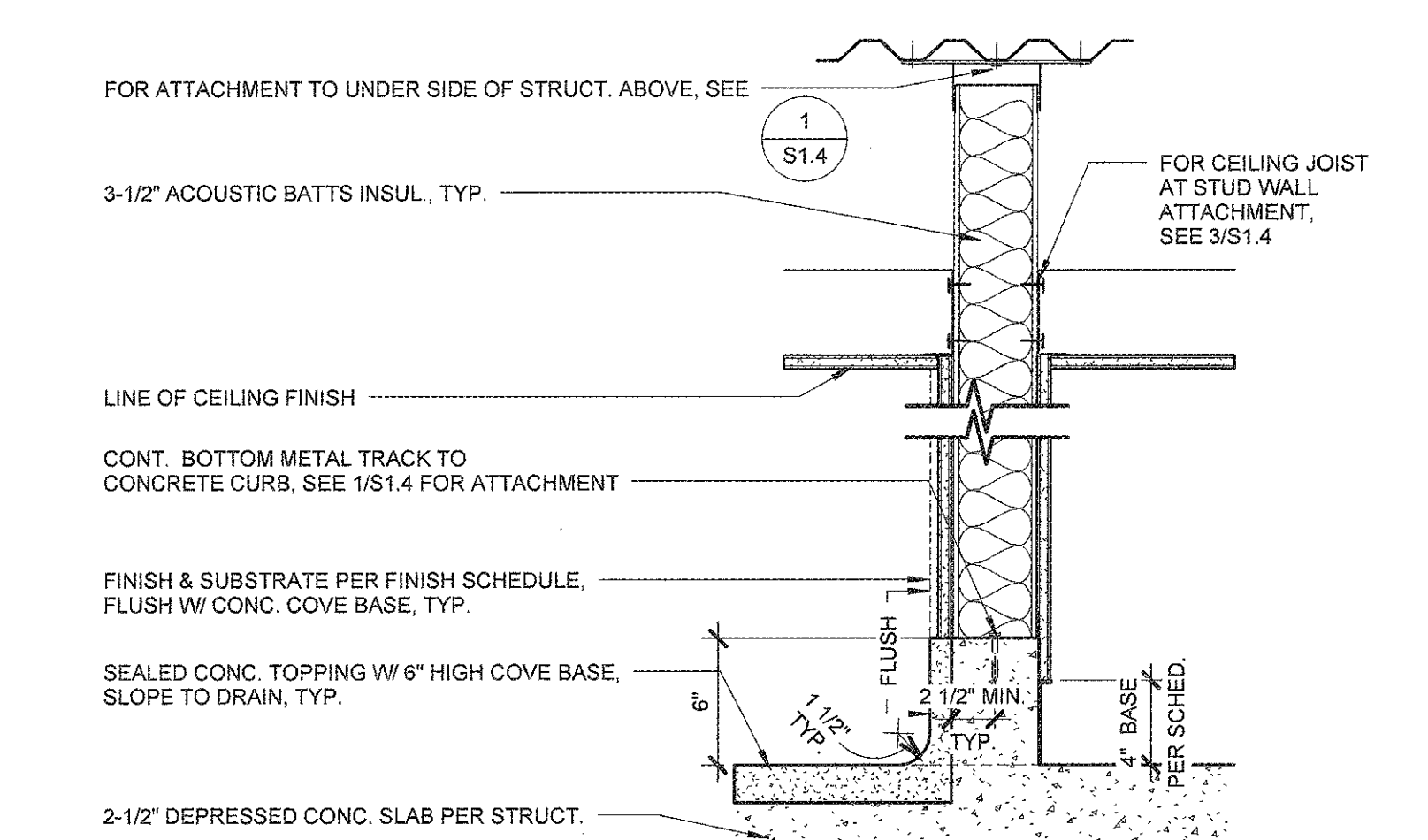

7 DEPRESSED CONC. SLAB @ CONC. COVE BASE
A9.0.1 1 1/2" = 1'-0"

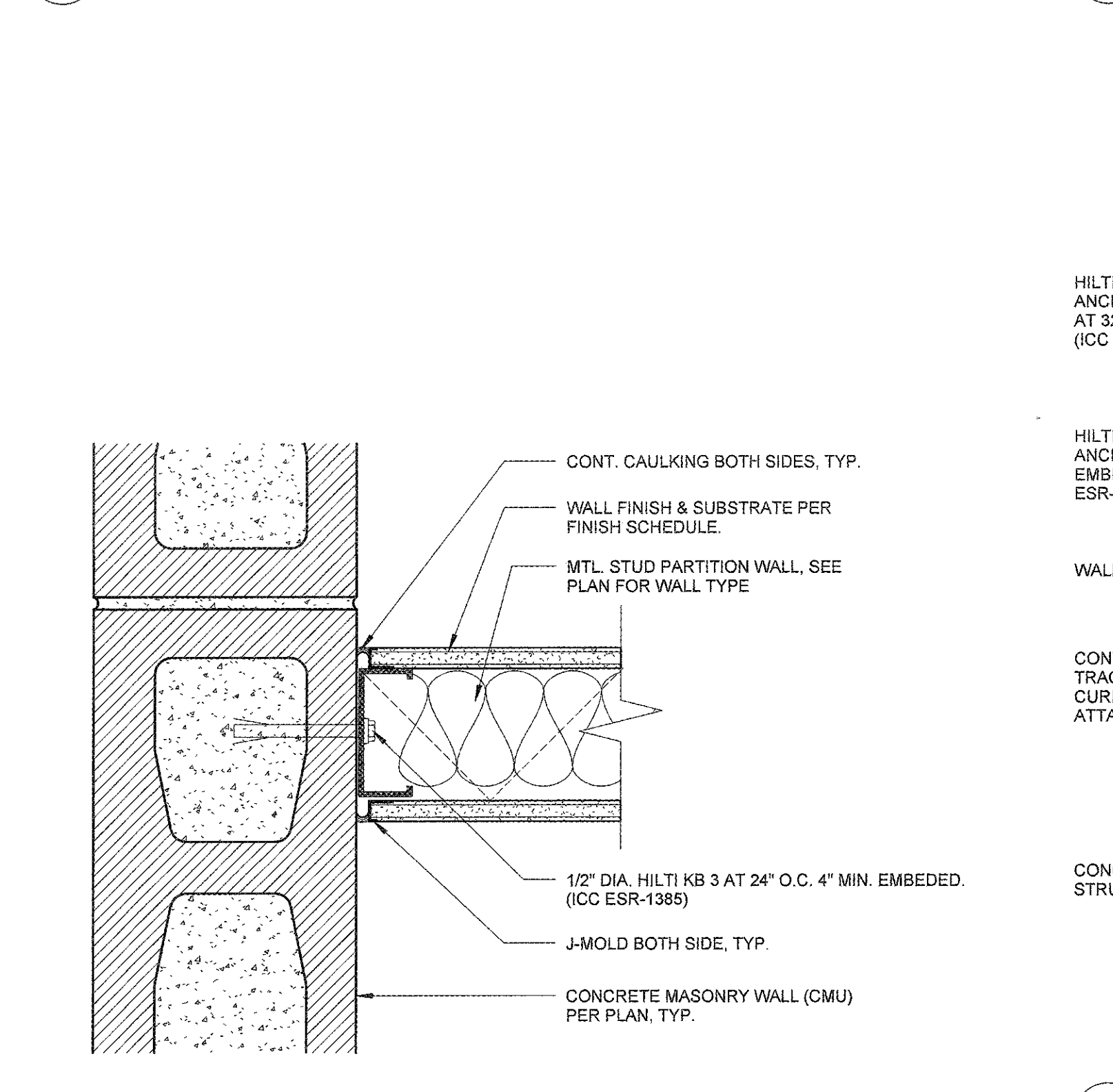

8 TYP. METAL STUD TO CMU WALL
A9.0.1 3" = 1'-0"

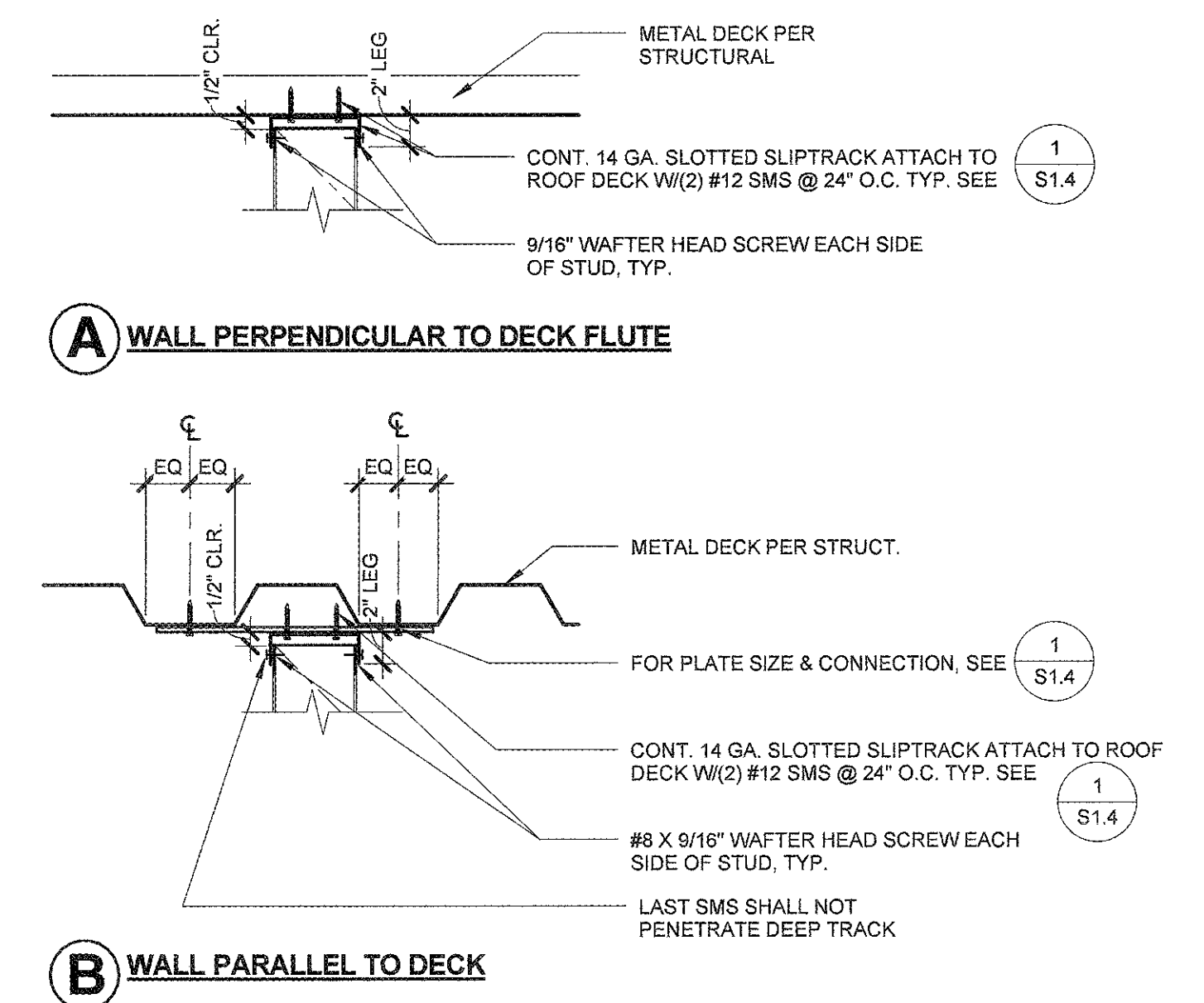

1 TYP. STUD CONNECTIONS AT MTL. DECKING
A9.0.1 1 1/2" = 1'-0"

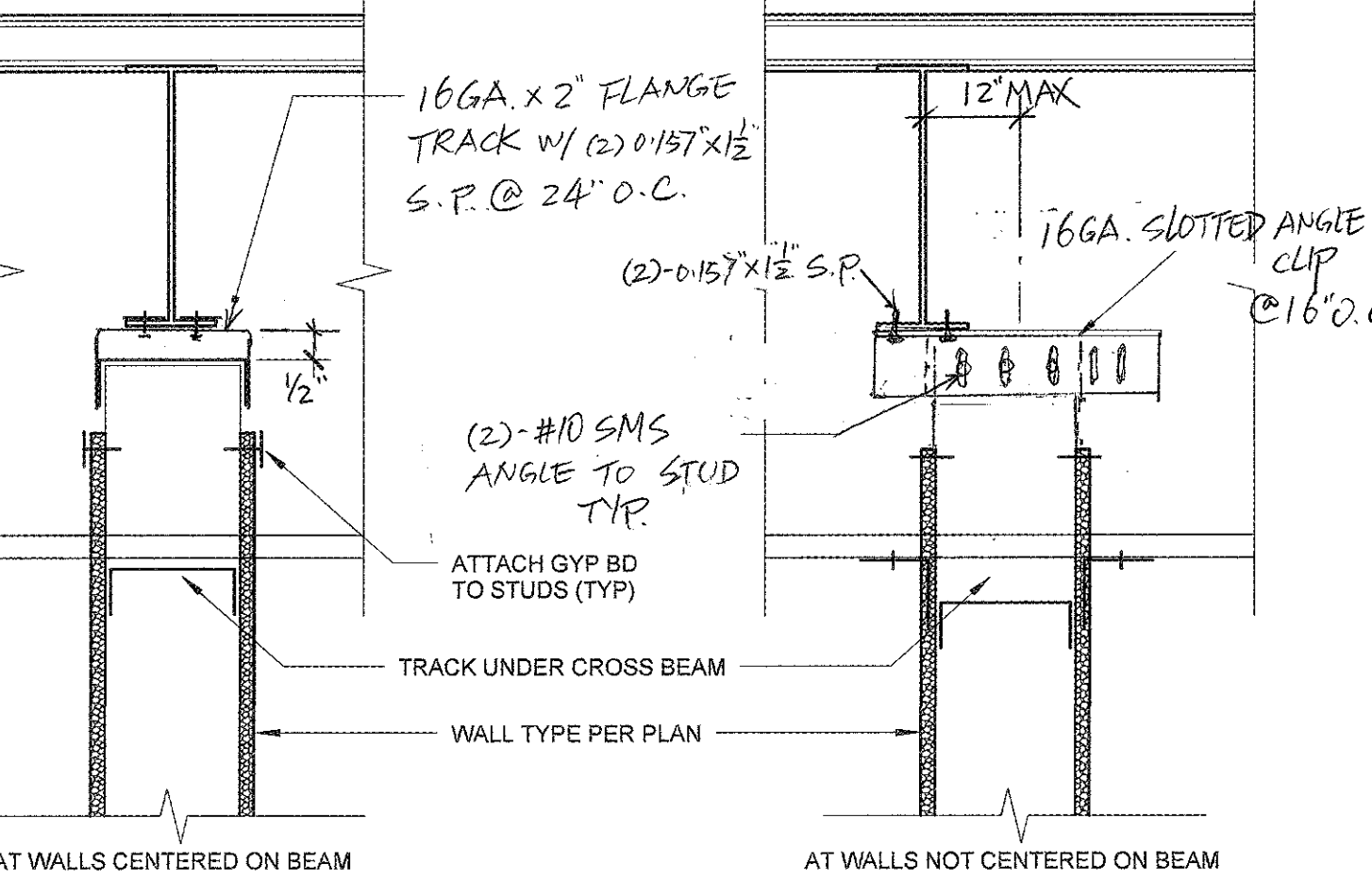

2 MTL STUD CONN. @ BEAM
A9.0.1 1 1/2" = 1'-0"

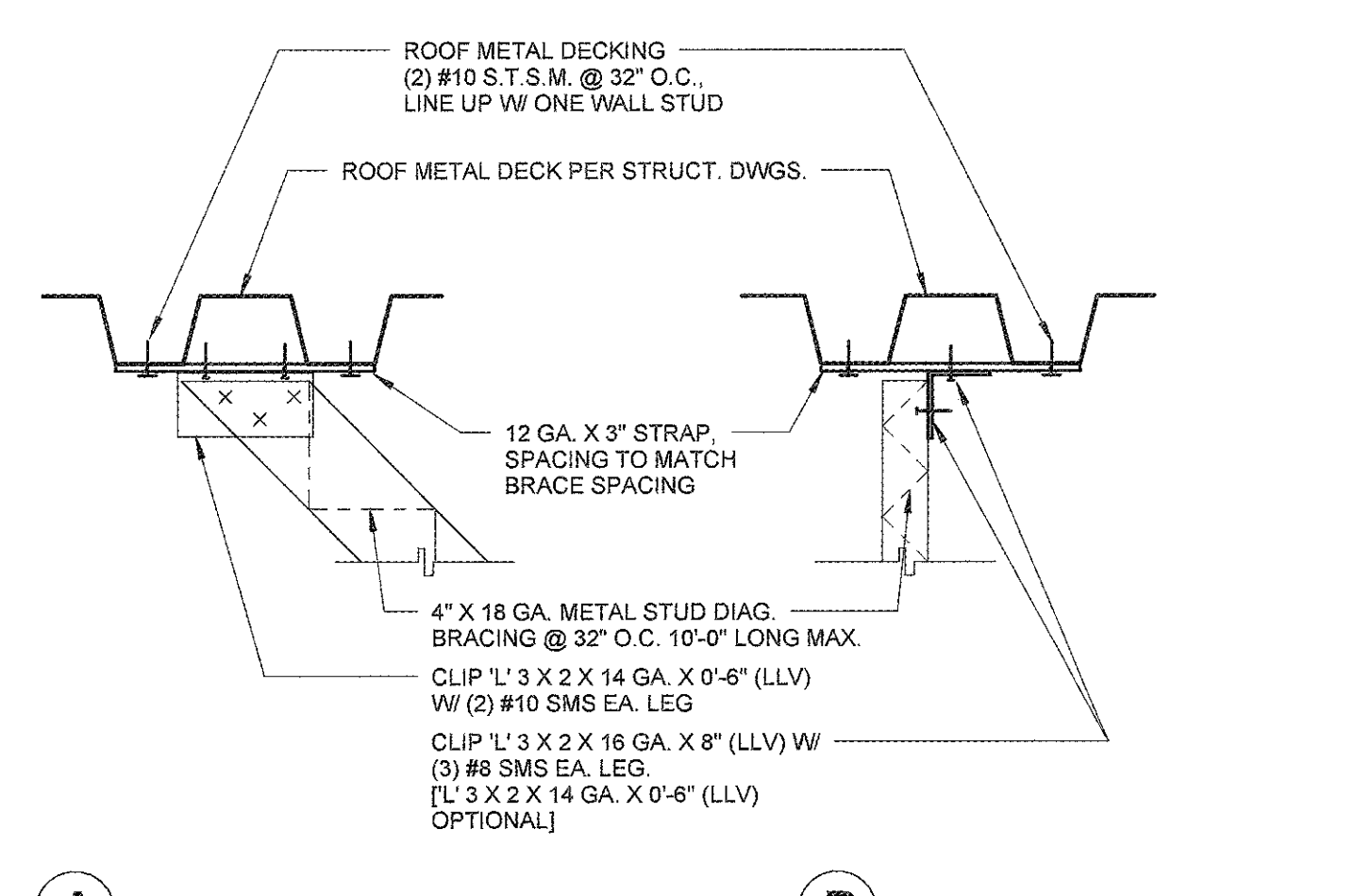

3 TYP. DIAGONAL BRACING DETAIL
A9.0.1 1 1/2" = 1'-0"

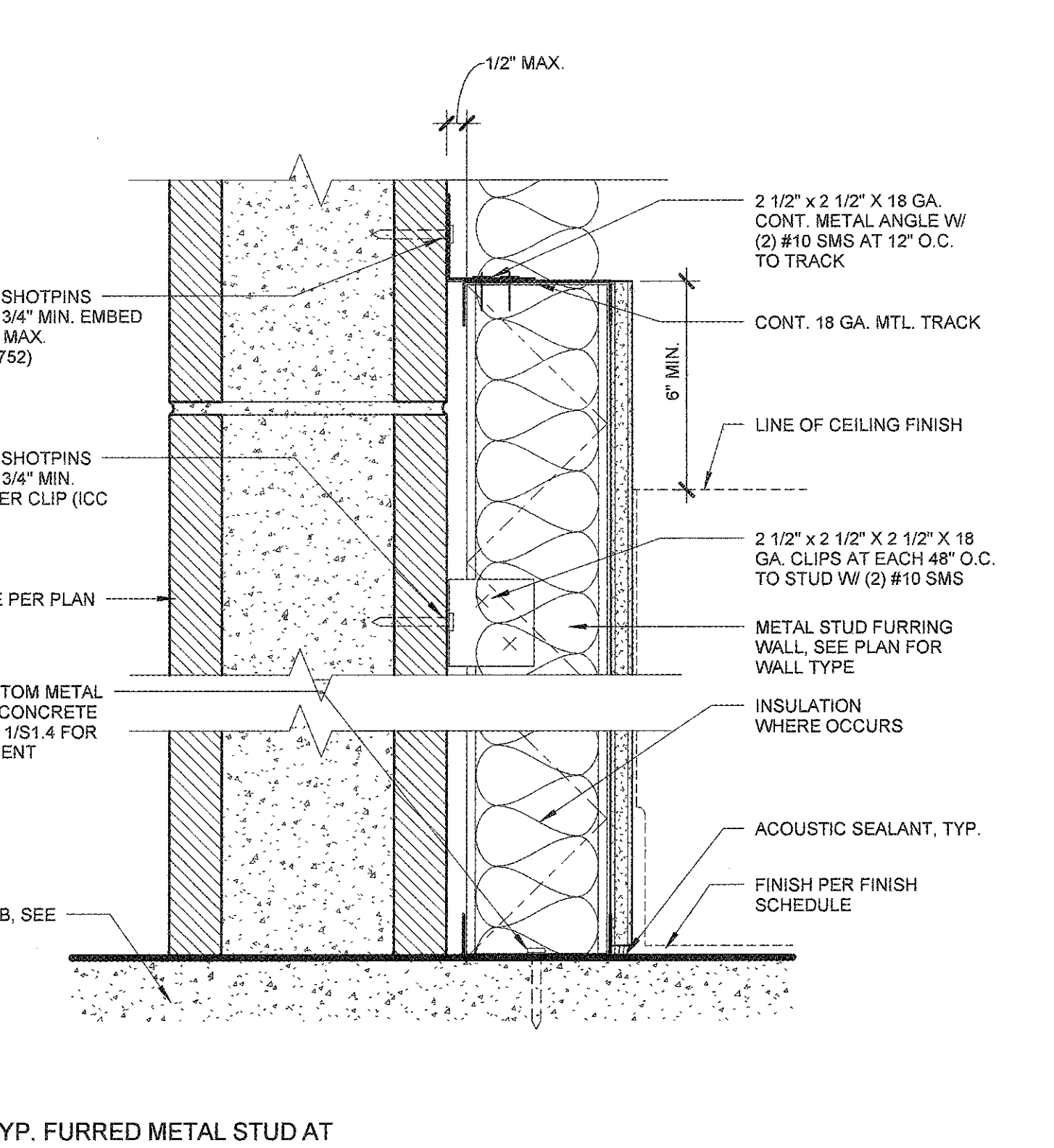

4 TYP. FURRED METAL STUD AT CMU WALL
A9.0.1 3" = 1'-0"

SCALE:	1" = 1'-0"	PER STRUCTURAL	C
FIRE RATING:	NON-RATED	CONCRETE MASONRY BLOCK CMU BLOCK	
ASSEMBLY REF:	N/A		
SOUND RATING:	N/A		
GENERAL NOTES:	1		
SCALE:	1" = 1'-0"	WALL TYPE PER PLAN	F1
FIRE RATING:	N/A	7/8" MTL. HAT CHANNEL FURRING @ 16" O.C., EXTEND 6" ABOVE FINISHED CEILING HEIGHT. ANCHORED W/ 1/2" DIA. X 1/2" S.P. @ 24" O.C.	
ASSEMBLY REF:	N/A		
SOUND RATING:	N/A	5/8" TYPE 'X' GYP. BD. TYP. ONE SIDE ONLY, EXTEND 6" ABOVE FINISHED CEILING HEIGHT, U.O.N.	
GENERAL NOTES:	2		
SCALE:	1" = 1'-0"	WALL TYPE PER PLAN	F2
FIRE RATING:	N/A	2 1/2" MTL. STUD @ 16" O.C., EXTEND 6" ABOVE FINISHED CEILING HEIGHT	
ASSEMBLY REF:	N/A	2" INSULATION, EXTEND 6" ABOVE FINISHED CEILING HEIGHT, ACUSTIC INSULATION WHERE REQUIRED, SEE PLAN	
SOUND RATING:	N/A	5/8" TYPE 'X' GYP. BD. TYP. ONE SIDE ONLY, EXTEND 6" ABOVE FINISHED CEILING HEIGHT, U.O.N. SEE DETAIL 4/A9.0.1	
GENERAL NOTES:	2	FRP WHERE OCCURS, WALL TYPE: F2R	
SCALE:	1" = 1'-0"	WALL TYPE PER PLAN	F2R
FIRE RATING:	N/A	4" MTL. STUD @ 16" O.C., EXTEND 6" ABOVE FINISHED CEILING HEIGHT	
ASSEMBLY REF:	N/A	3-1/2" INSULATION, EXTEND 6" ABOVE FINISHED CEILING HEIGHT, ACUSTIC INSULATION WHERE REQUIRED, SEE PLAN	
SOUND RATING:	N/A	5/8" TYPE 'X' GYP. BD. TYP. ONE SIDE ONLY, EXTEND 6" ABOVE FINISHED CEILING HEIGHT, U.O.N. SEE DETAIL 4/A9.0.1	
GENERAL NOTES:	2		
SCALE:	1" = 1'-0"	WALL TYPE PER PLAN	F4
FIRE RATING:	N/A	2" INSULATION, EXTEND TO STRUCT. ABOVE ACUSTIC INSULATION WHERE REQUIRED, SEE PLAN	
ASSEMBLY REF:	N/A	2 1/2" MTL. STUD @ 16" O.C., EXTEND TO STRUCT. ABOVE	
SOUND RATING:	N/A	1 1/2" STL. CHANNEL BRACING @ 48" O.C. VERTICALLY WHERE OCCURS.	
GENERAL NOTES:	2	5/8" WATER RESISTANT TYPE 'X' GYP. BD. OVER W.R. MEMBRANES, EXTEND TO STRUCT. ABOVE	
SCALE:	1" = 1'-0"	WALL TYPE PER PLAN	F2T
FIRE RATING:	N/A	2 1/2" MTL. STUD @ 16" O.C., EXTEND TO STRUCT. ABOVE	
ASSEMBLY REF:	N/A	1 1/2" STL. CHANNEL BRACING @ 48" O.C. VERTICALLY WHERE OCCURS.	
SOUND RATING:	N/A	5/8" WATER RESISTANT TYPE 'X' GYP. BD. OVER W.R. MEMBRANES, EXTEND TO STRUCT. ABOVE	
GENERAL NOTES:	2	TILE OVER THIN-SET, PATTERN, FINISH, & HEIGHT PER INTERIOR ELEVATION PLUMBING CLEARANCE PER PLAN.	
SCALE:	1" = 1'-0"	WALL TYPE PER PLAN	F4T
FIRE RATING:	N/A	3-1/2" INSULATION, EXTEND 6" ABOVE FINISHED CEILING HEIGHT. ACUSTIC INSULATION WHERE REQUIRED, SEE PLAN.	
ASSEMBLY REF:	N/A	4" MTL. STUD @ 16" O.C., EXTEND 6" ABOVE FINISHED CEILING HEIGHT	
SOUND RATING:	N/A	5/8" WATER RESISTANT TYPE 'X' GYP. BD. OVER W.R. MEMBRANES, EXTEND 6" ABOVE FINISHED CEILING HEIGHT	
GENERAL NOTES:	2	TILE OVER THIN-SET, PATTERN, FINISH, & HEIGHT PER INTERIOR ELEVATION	
SCALE:	1" = 1'-0"	WALL TYPE PER PLAN	4
FIRE RATING:	NON-RATED	4" MTL. STUD @ 16" O.C., EXTEND TO STRUCT. ABOVE	
ASSEMBLY REF:	N/A	3-1/2" INSULATION, EXTEND TO STRUCT. ABOVE ACUSTIC INSULATION WHERE REQUIRED, SEE PLAN.	
SOUND RATING:	N/A	5/8" TYPE 'X' GYP. BD., TYP. BOTH SIDES EXTEND TO UNDERSIDE OF STRUCT. ABOVE	
GENERAL NOTES:	2	FRP WHERE OCCURS, WALL TYPE: 4R & 4R4	
SCALE:	1" = 1'-0"	WALL TYPE PER PLAN	6
FIRE RATING:	NON-RATED	6" MTL. STUD @ 16" O.C., EXTEND TO STRUCT. ABOVE	
ASSEMBLY REF:	N/A	5-1/2" INSULATION, EXTEND TO STRUCT. ABOVE ACUSTIC INSULATION WHERE REQUIRED, SEE PLAN.	
SOUND RATING:	N/A	5/8" TYPE 'X' GYP. BD., TYP. BOTH SIDES EXTEND TO UNDERSIDE OF STRUCT. ABOVE	
GENERAL NOTES:	2		
SCALE:	1" = 1'-0"	WALL TYPE PER PLAN	4T
FIRE RATING:	N/A	3-1/2" INSULATION, EXTEND TO STRUCT. ABOVE. ACUSTIC INSULATION WHERE REQUIRED, SEE PLAN.	
ASSEMBLY REF:	N/A	4" MTL. STUD @ 16" O.C., EXTEND TO STRUCT. ABOVE.	
SOUND RATING:	N/A	5/8" WATER RESISTANT TYPE 'X' GYP. BD. OVER W.R. MEMBRANES, EXTEND TO STRUCT. ABOVE.	
GENERAL NOTES:	2	TILE OVER THIN-SET ONE SIDE, PATTERN, FINISH, & HEIGHT PER INTERIOR ELEVATION	
SCALE:	1" = 1'-0"	WALL TYPE PER PLAN	6T
FIRE RATING:	N/A	5-1/2" INSULATION, EXTEND TO STRUCT. ABOVE. ACUSTIC INSULATION WHERE REQUIRED, SEE PLAN.	
ASSEMBLY REF:	N/A	6" MTL. STUD @ 16" O.C., EXTEND TO STRUCT. ABOVE.	
SOUND RATING:	N/A	5/8" WATER RESISTANT TYPE 'X' GYP. BD. OVER W.R. MEMBRANES, EXTEND TO STRUCT. ABOVE.	
GENERAL NOTES:	2	TILE OVER THIN-SET ONE SIDE, PATTERN, FINISH, & HEIGHT PER INTERIOR ELEVATION	
SCALE:	1" = 1'-0"	WALL TYPE PER PLAN	T4T
FIRE RATING:	N/A	3-1/2" INSULATION, EXTEND TO STRUCT. ABOVE. ACUSTIC INSULATION WHERE REQUIRED, SEE PLAN.	
ASSEMBLY REF:	N/A	4" MTL. STUD @ 16" O.C., EXTEND TO STRUCT. ABOVE.	
SOUND RATING:	N/A	5/8" WATER RESISTANT TYPE 'X' GYP. BD. OVER W.R. MEMBRANES, EXTEND TO STRUCT. ABOVE, TYP. OF EA. SIDE.	
GENERAL NOTES:	2	TILE OVER THIN-SET ONE SIDE, PATTERN, FINISH, & HEIGHT PER INTERIOR ELEVATION, TYP. OF EA. SIDE	
SCALE:	1" = 1'-0"	WALL TYPE PER PLAN	4BP
FIRE RATING:	NON-RATED	4" MTL. STUD @ 16" O.C., EXTEND TO STRUCT. ABOVE	
ASSEMBLY REF:	N/A	3-1/2" INSULATION, EXTEND TO STRUCT. ABOVE. ACUSTIC INSULATION WHERE REQUIRED, SEE PLAN.	
SOUND RATING:	N/A	5/8" TYPE 'X' GYP. BD., EXTEND TO UNDERSIDE OF STRUCT. ABOVE	
GENERAL NOTES:	2	7/16" LEVEL 3 BULLET RESISTIVE PANEL, SEE SPEC. SECTION 11 16 00	
SCALE:	1" = 1'-0"	WALL TYPE PER PLAN	
FIRE RATING:	NON-RATED	3-1/2" INSULATION, EXTEND TO STRUCT. ABOVE. ACUSTIC INSULATION WHERE REQUIRED, SEE PLAN.	
ASSEMBLY REF:	N/A	5/8" TYPE 'X' GYP. BD., EXTEND TO UNDERSIDE OF STRUCT. ABOVE	
SOUND RATING:	N/A	3/4" PLYWOOD SHEATHING EXTEND TO UNDERSIDE OF STRUCTURE ABOVE, FINISH PER SCHEDULE.	
GENERAL NOTES:	2		

- GENERAL NOTES
- SEE SPEC. SECTION 04 22 00. PROVIDE CMU PER ARCHITECTURAL SHEET A9.0.1. SEE STRUCTURAL FOR SIZE, REINFORCEMENT & ADDITIONAL INFORMATION.
 - SEE SPEC. SECTION 05 41 00. MTL. STUD THICKNESS SHALL BE 20 GA MIN & DEPENDENT ON HEIGHT AND SPAN. SEE STRUCTURAL AND MTL. STUD. MANUFACTURER FOR ADDITIONAL INFORMATION.
 - WALLS WITH CASEWORK ELECTRICAL PANELS, & WALL HUNG PLUMBING FIXTURES METAL STUDS SHALL BE 16 GA MIN. UNLESS OTHERWISE NOTED.
 - ALL WALLS SHALL EXTEND TO UNDERSIDE OF DECK ABOVE, U.O.N. FOR DECK TERMINATION DETAILS REFER TO 2/A9.0.1 FOR METAL STUD CONNECTIONS & SECTION PROPERTIES.
 - REFER TO 1/S1.3 & 9/S1.3 RESPECTIVELY.
 - ALL GYPSUM BOARD SHEETS TO RUN VERTICALLY. NO JOINTS EXCEPT AT STUDS.
 - ALL SCREWS SHALL PENETRATE STUDS.
 - 12" CEMENTITIOUS TILE BACKER BOARD AT PORTIONS OF WALLS WITH CERAMIC TILE.
 - BLDG. INSULATION MATERIALS SHALL NOT EXCEED FLAME SPREAD RATINGS OF 25 OR SMOKE DENSITY OF 450 PER SEC. SECT. 719.
 - FOR WALLS WITH ACUSTICAL INSULATION, SEE PLAN & SPECIFICATIONS FOR MORE INFORMATION.
 - WHERE METAL STUDS HIT ROOF FRAMING, SEE DETAIL 2/A9.0.1 FOR MORE INFORMATION ON INSULATION, SEE SPEC. SECTION 07 21 00.

**COMPTON
CCD**

CAMPUS PUBLIC SAFETY BUILDING

**1111 EAST ARTESIA BOULEVARD,
COMPTON CALIFORNIA 90221**

PROJECT REVIEW

IDENTIFICATION STAMP DIV. OF THE STATE ARCHITECT OFFICE OF REGULATION SERVICES	
FILE NO:	19-C1
AR:	03-117673
AC:	FILED SS
DATE:	DEC 12 2017

REVISIONS

NO	REASON	DATE

PROJECT TEAM

PRINCIPAL IN CHARGE
RITA S. CARTER
PROJECT MANAGER
SHOJI TAKESHIMA / DAVID PHAN
DRAWN BY
DAVID PHAN

SCALE

1" = 1'-0"

DATE

12/01/16

A9.0.2

PROJECT NUMBER

913-4675-00



PROJECT TITLE

TYP. MTL. STUD FRAMING & EXTERIOR DETAILS

PROJECT NUMBER

913-4675-00

PROJECT TITLE

TYP. MTL. STUD FRAMING & EXTERIOR DETAILS

PROJECT NUMBER

913-4675-00

PROJECT TITLE

TYP. MTL. STUD FRAMING & EXTERIOR DETAILS

PROJECT NUMBER

913-4675-00

PROJECT TITLE

TYP. MTL. STUD FRAMING & EXTERIOR DETAILS

PROJECT NUMBER

913-4675-00

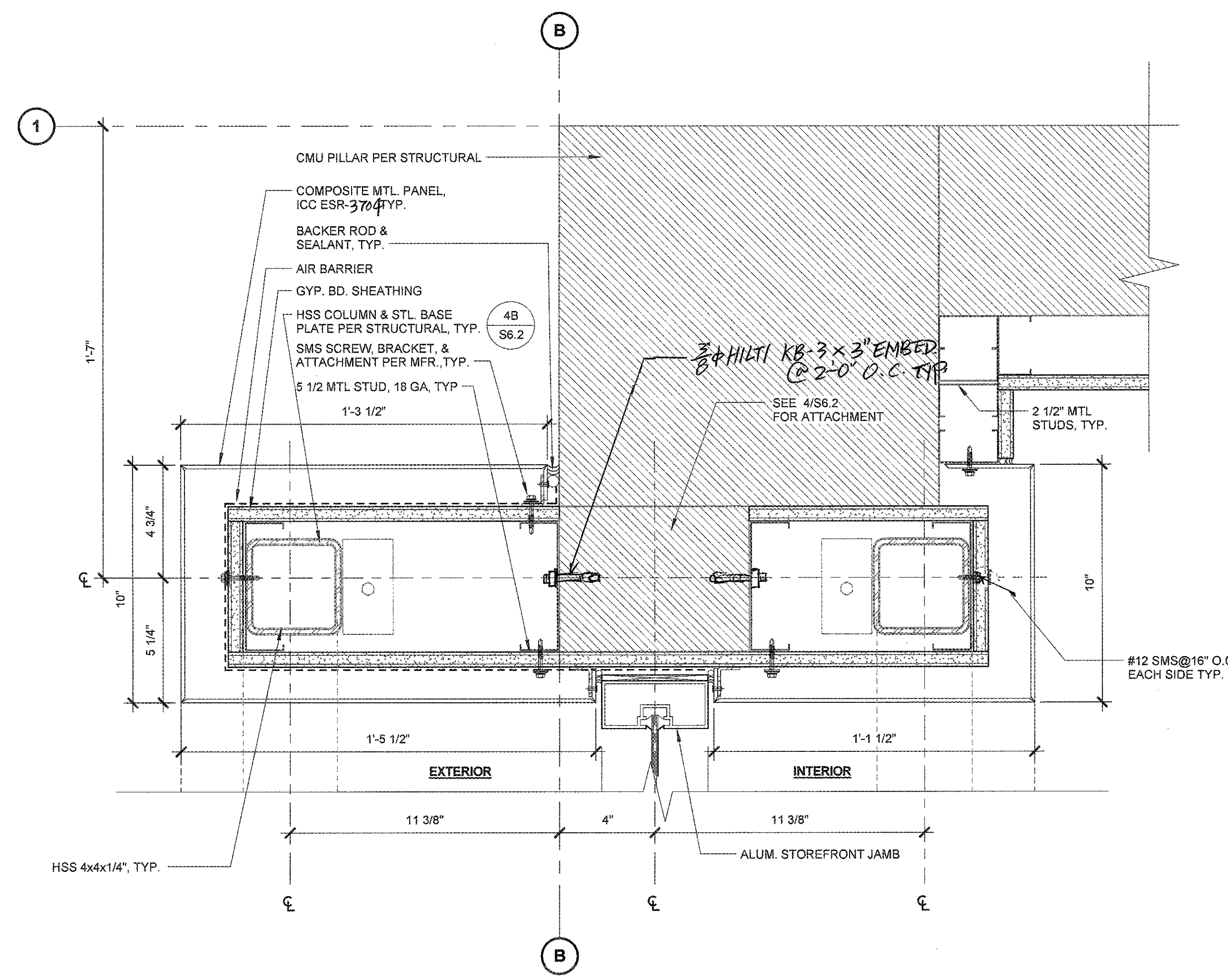

3 MAIN ENTRANCE JAMB DETAIL
A8.0.2 3" = 1'-0"

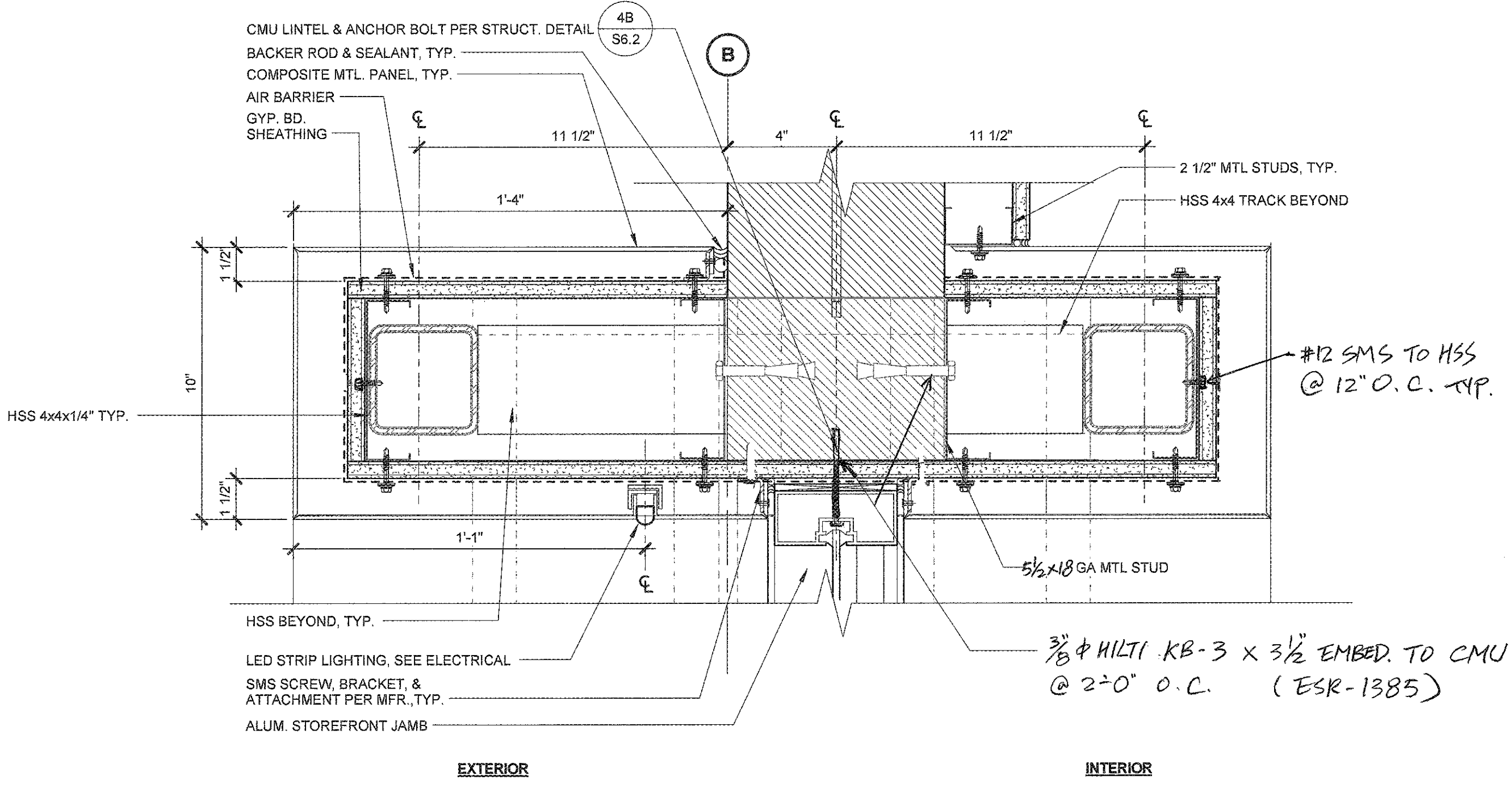

4 STOREFRONT HEAD @ ENTRY
A8.0.2 3" = 1'-0"

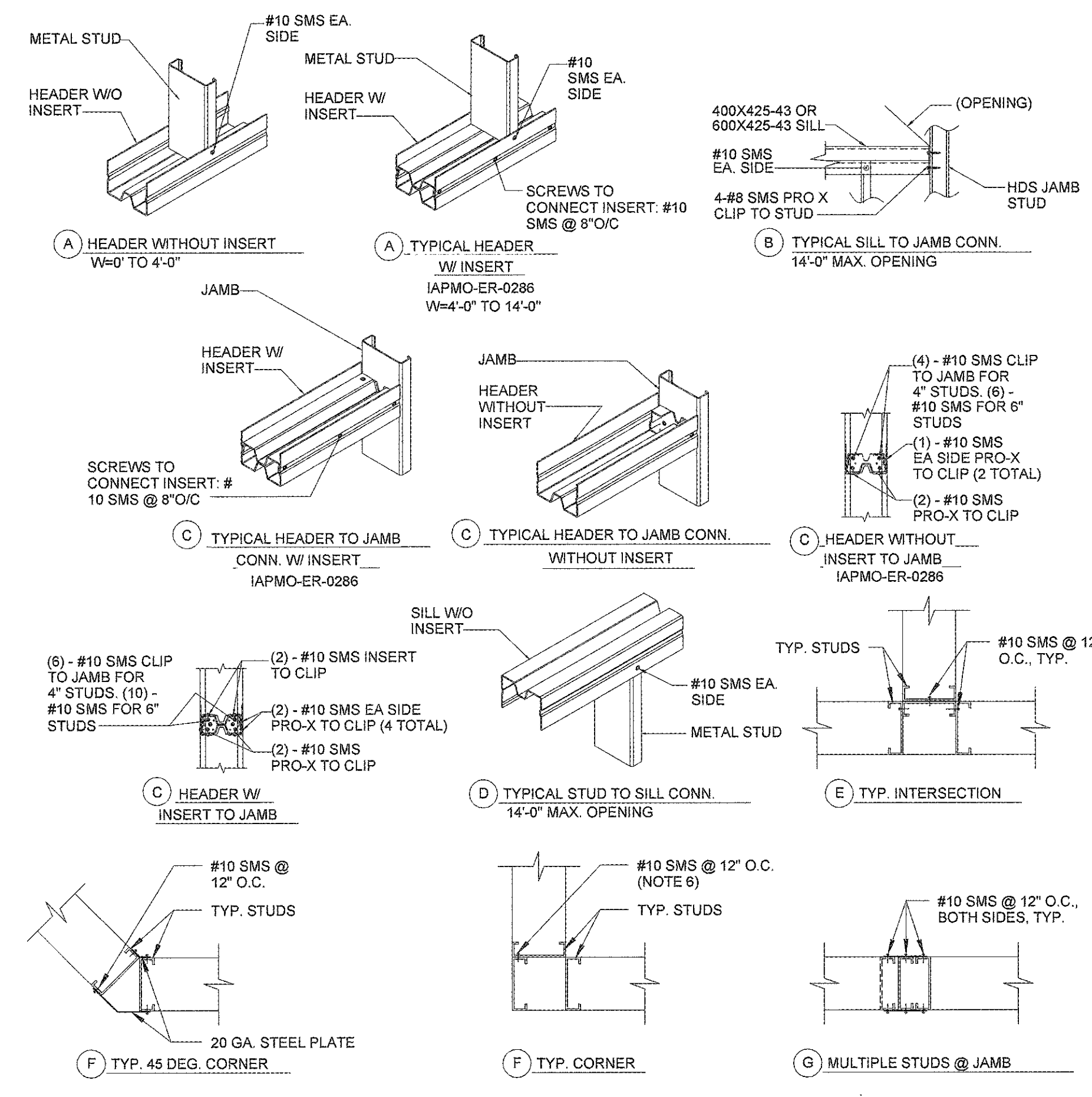

1 PRO-X METAL STUD FRAMING OPTION
A8.0.2 1" = 1'-0"

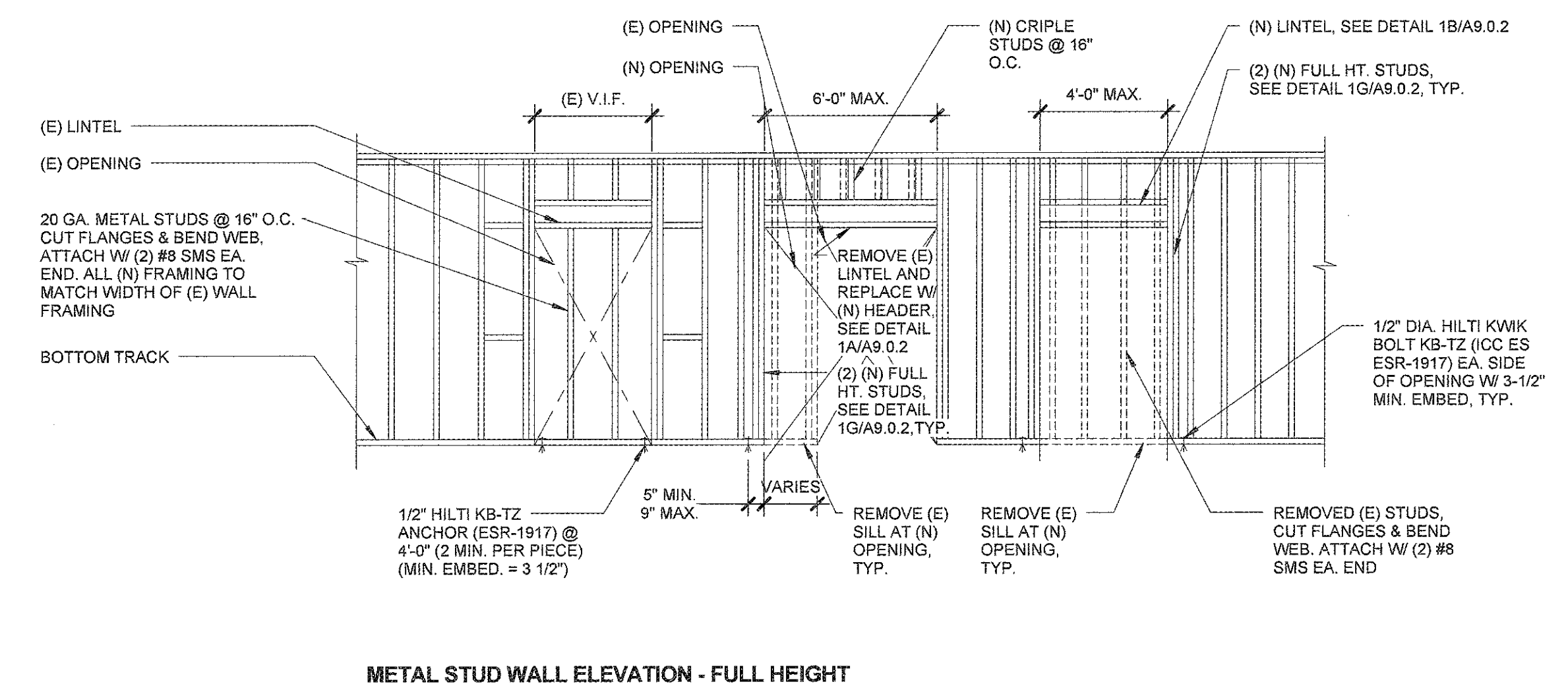

METAL STUD WALL ELEVATION - FULL HEIGHT

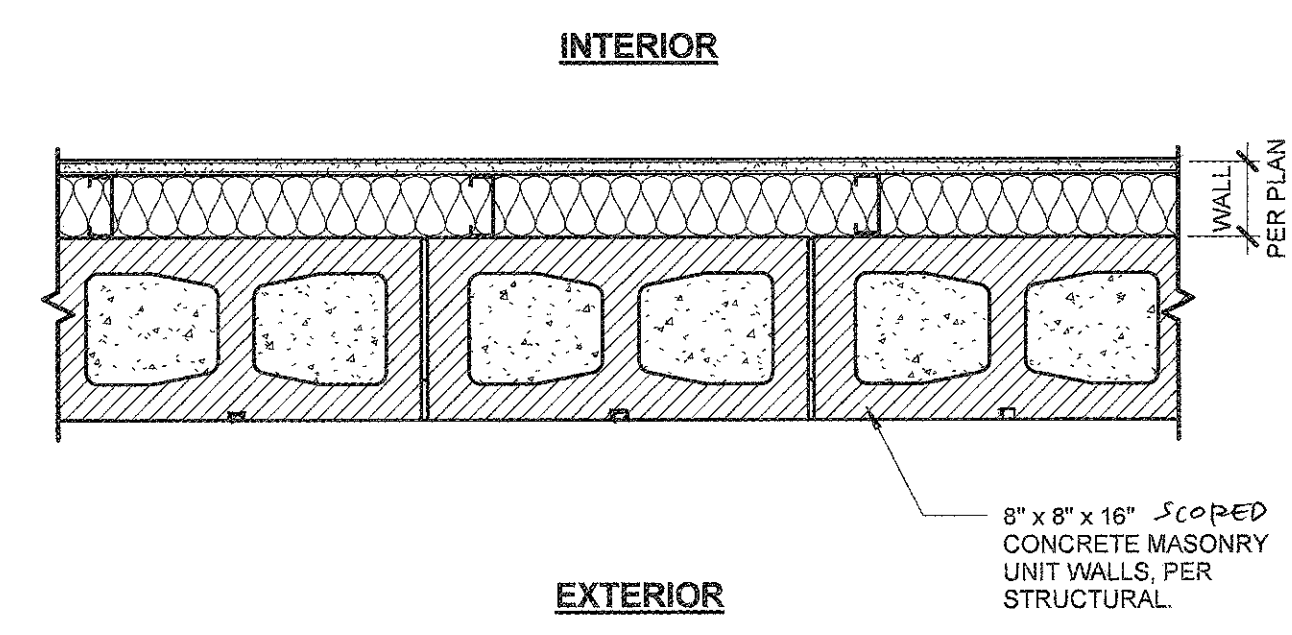

2 CMU ACCENT
A8.0.2 1 1/2" = 1'-0"

NOT USED

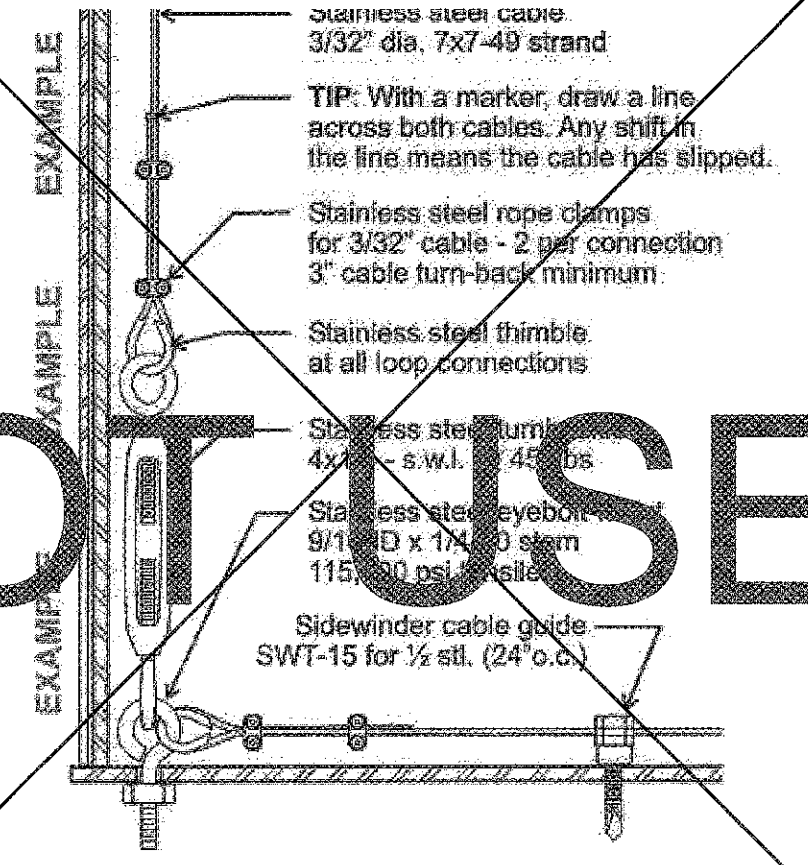

12 NET ATTACHMENT
 A9.1.1 6" = 1'-0"

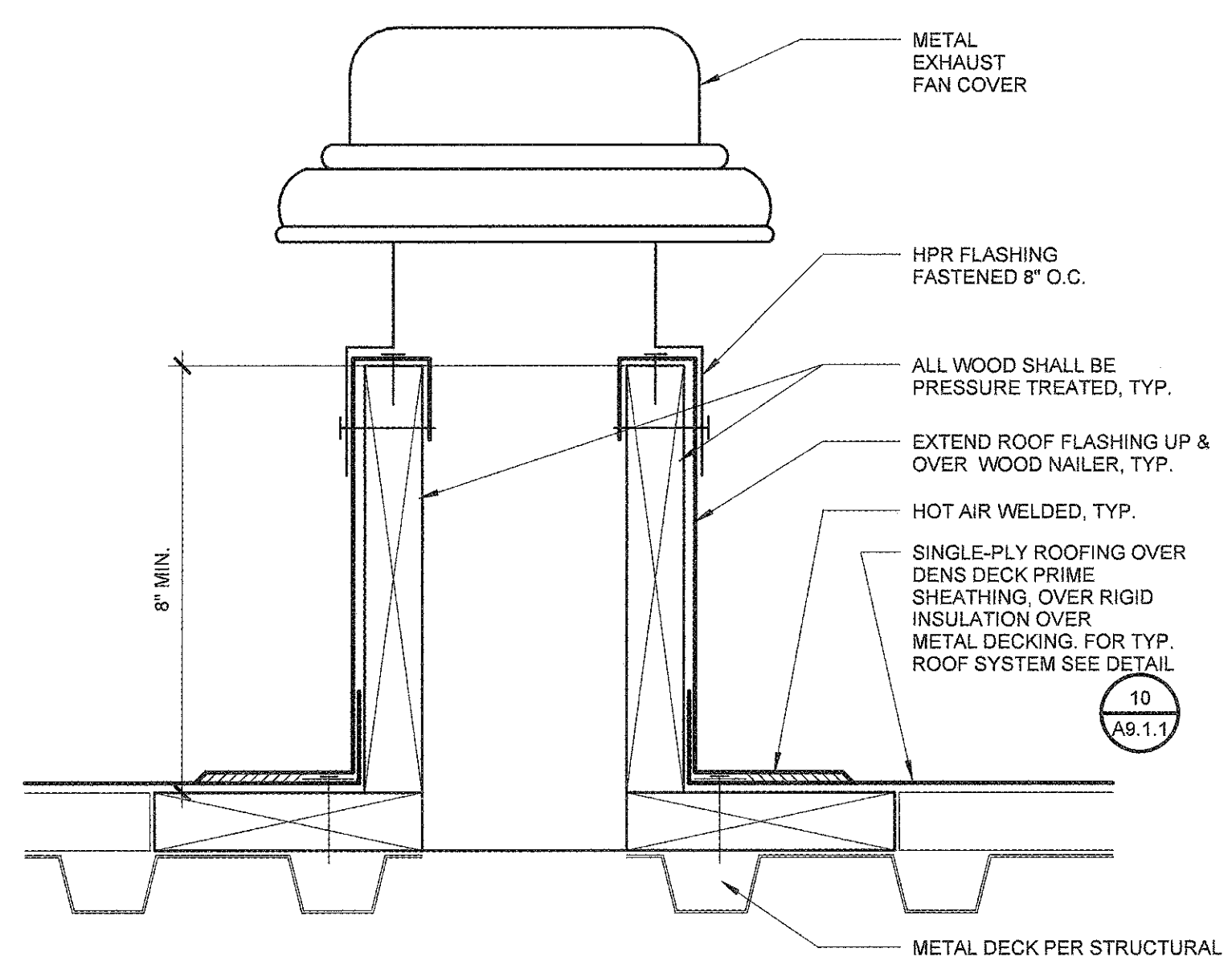

8 EXHAUST FAN DETAIL
 A9.1.1 12" = 1'-0"

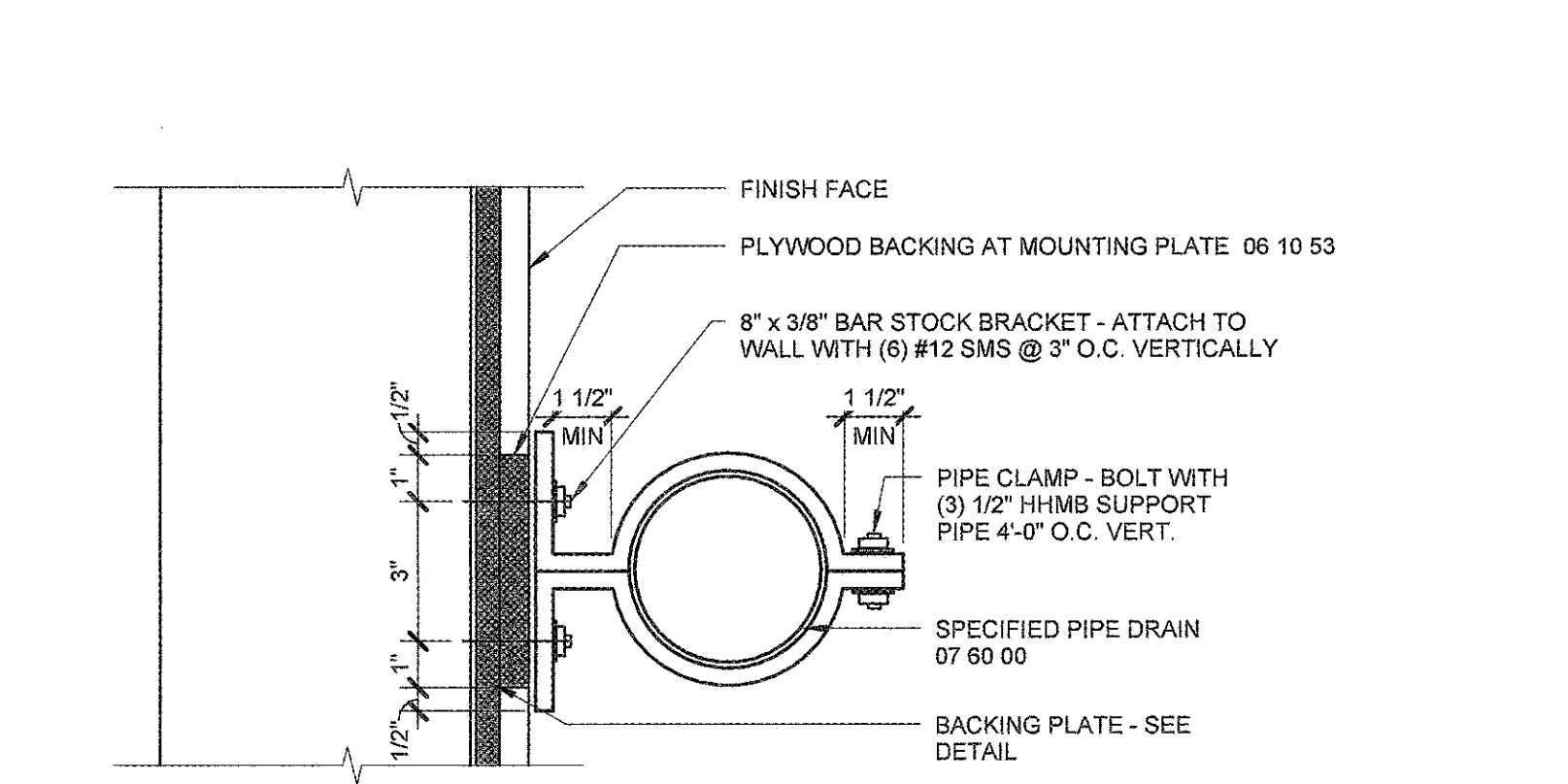

4 TYP. DOWNSPOUT ATTACHMENT BRACKET
 A9.1.1 3" = 1'-0"

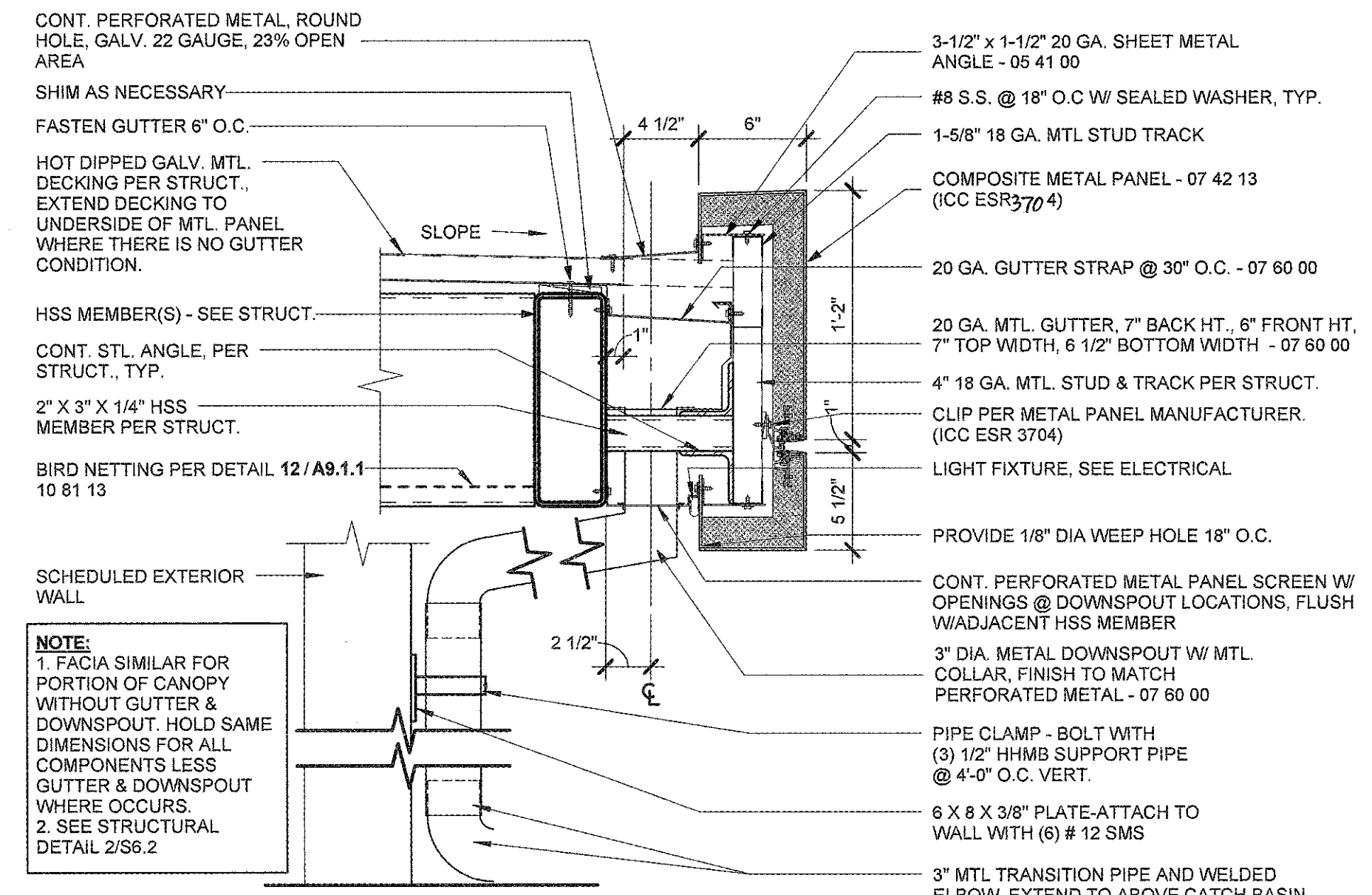

1 TYP. GUTTER AT CANOPY
 A9.1.1 1 1/2" = 1'-0"

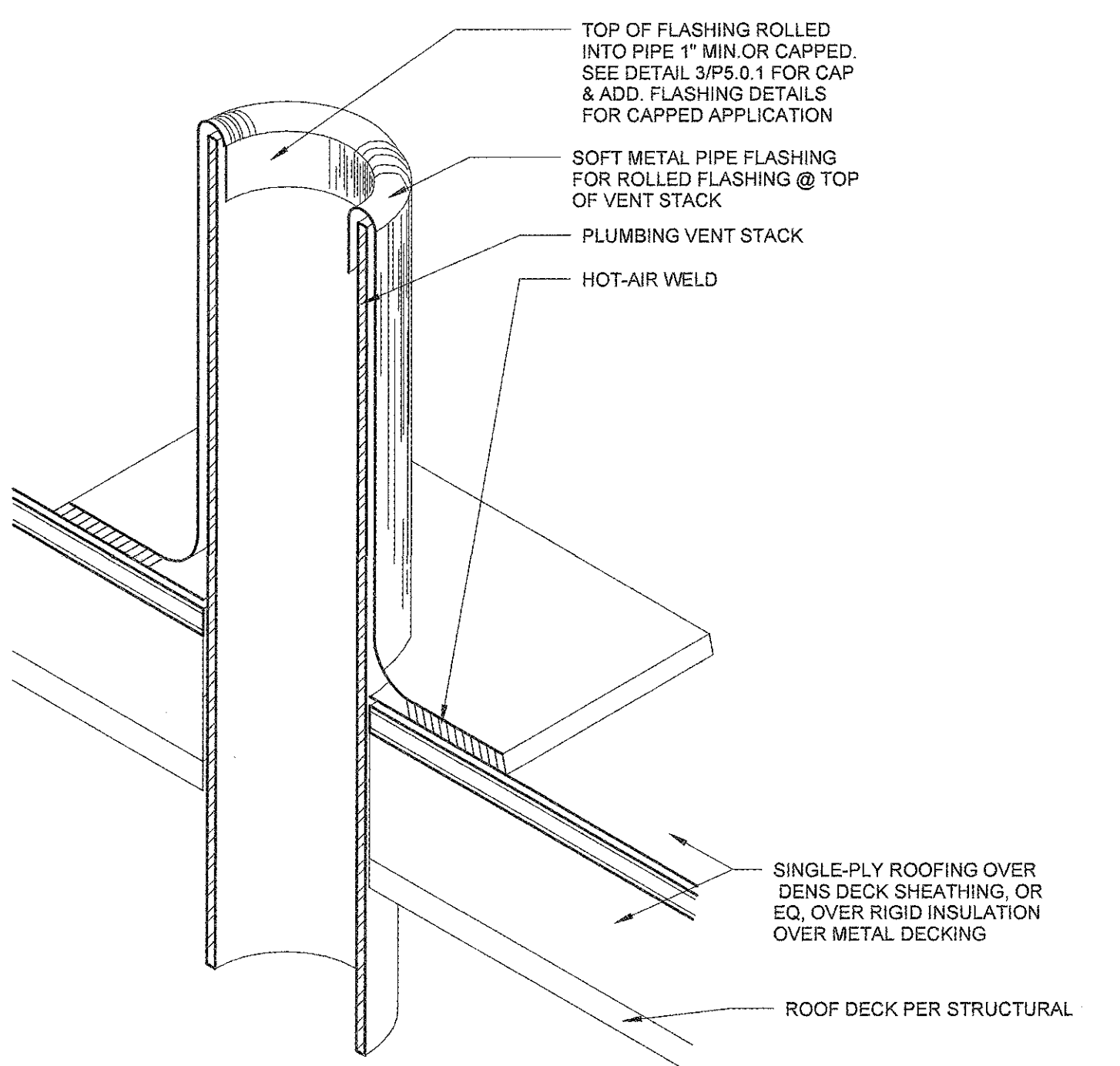

- NOTES:
 1. SOFT METAL PIPE FLASHING - ALUM PER SPECS OR SHEET COPPER, MINIMUM 16 OZ SATURATED ROOFING FELT, WRAPPED AROUND PIPE, TO SEPARATE THE COPPER FLASHING FROM DIRECT CONTACT WITH PIPE, TO REDUCE GALVANIC ACTION.
 2. VENT STACKS AND OTHER PIPES SHOULD HAVE A MINIMUM OF 12 INCHES OF CLEARANCE ON ALL SIDES FROM WALLS, CURBS, AND OTHER PROJECTIONS TO FACILITATE PROPER FLASHING.
 3. NRCA SUGGESTS THAT THE TOP STRIPPING PLY BE A HEAVY-WEIGHT POLYMER MODIFIED BITUMEN SHEET.

9 TYP. VENT STACK FLASHING
 A9.1.1 3" = 1'-0"

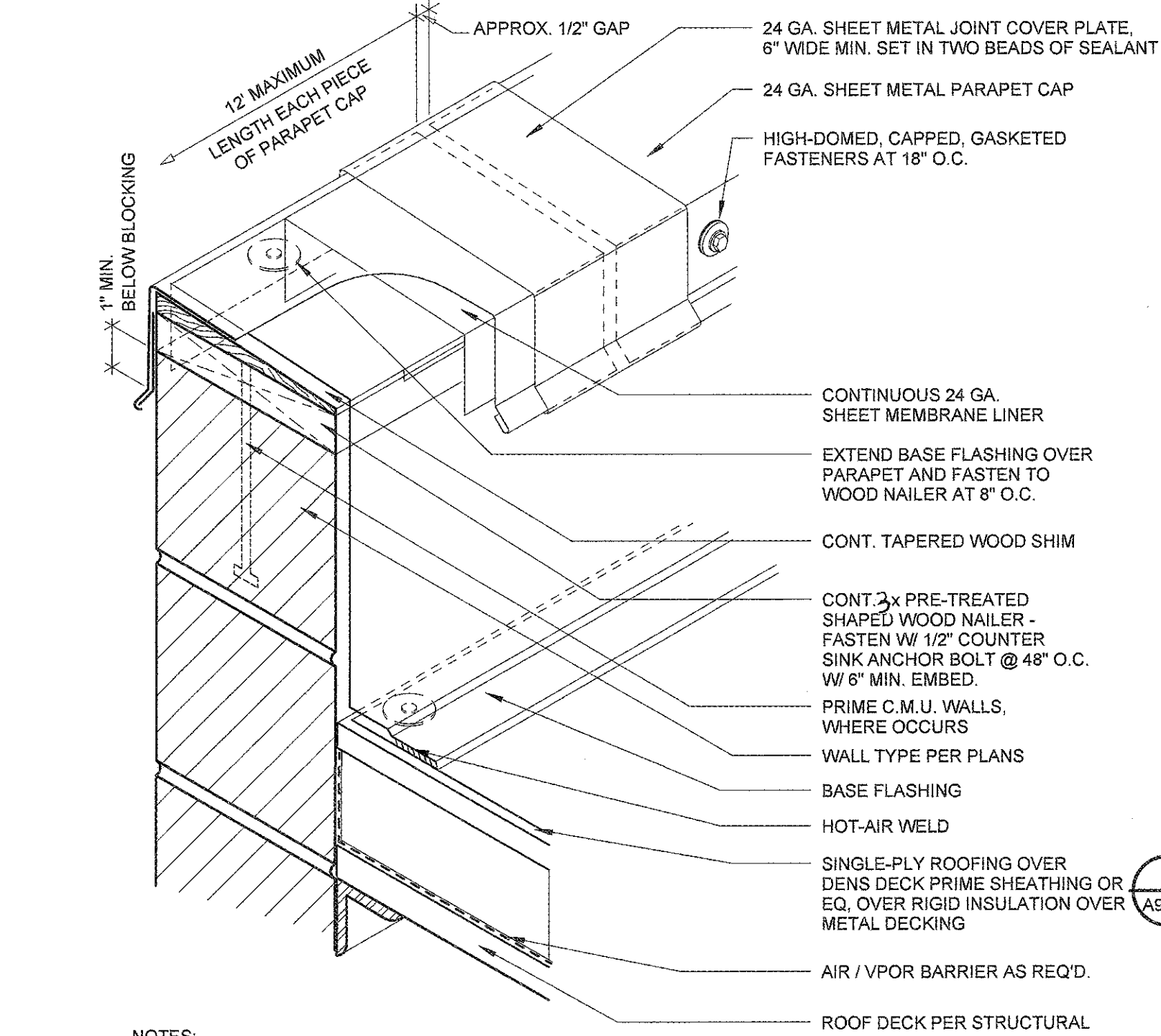

- NOTES:
 1. THIS DETAIL SHOULD BE USED ONLY WHEN THE ROOF DECK IS SUPPORTED BY THE WALL. (REFER TO STRUCT.)
 2. ATTACH NAILER TO DECK WITH SUITABLE FASTENERS.
 3. FIBER CANT STRIP SHALL BE SET IN BITUMEN OR ROOF ADHESIVE.

5 TYP. ROOF FLASHING & COPING @ PARAPET
 A9.1.1 3" = 1'-0"

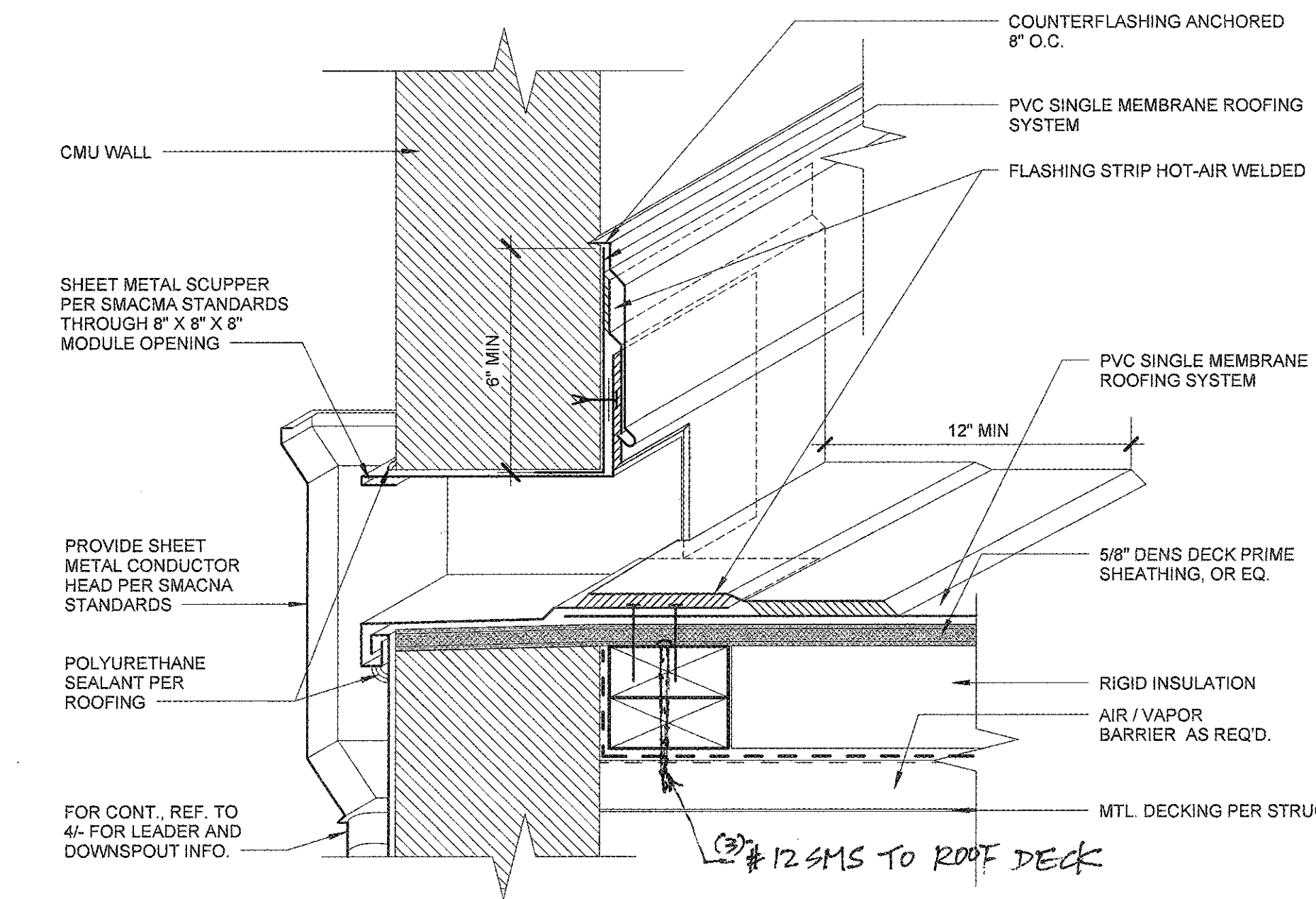

2 TYP. SCUPPER THRU WALL - ROOF TYPE 1A
 A9.1.1 3" = 1'-0"

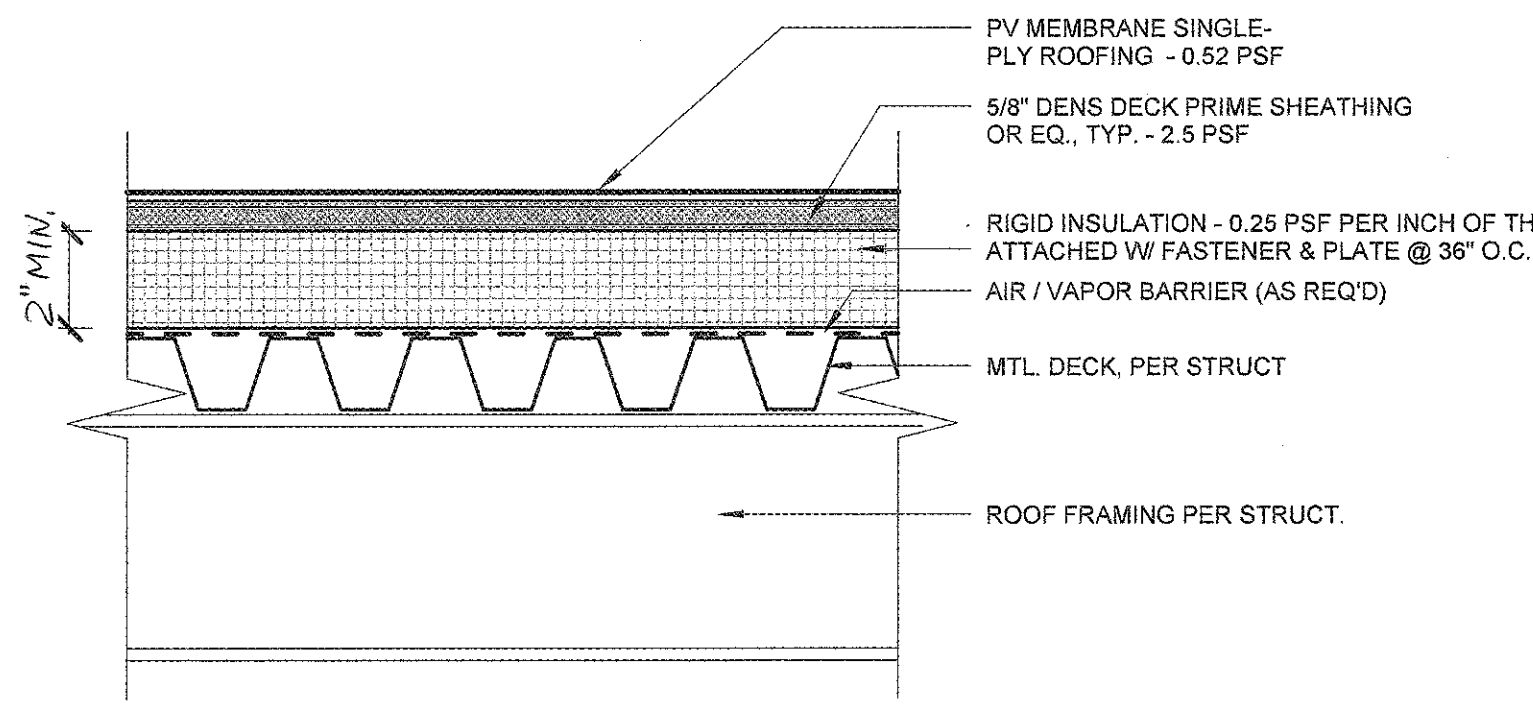

10 TYP. ROOF SYSTEM
 A9.1.1 3" = 1'-0"

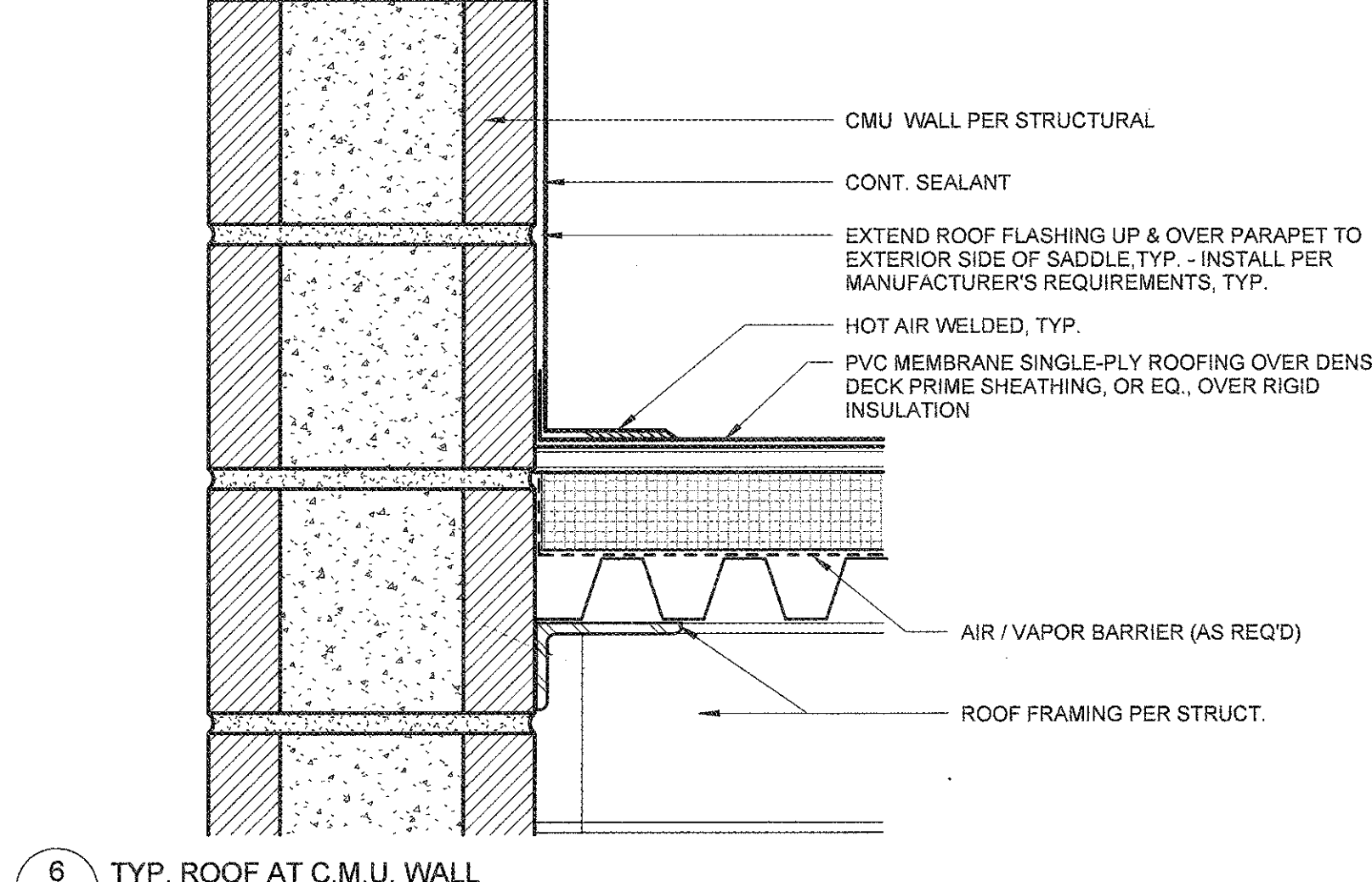

6 TYP. ROOF AT C.M.U. WALL
 A9.1.1 3" = 1'-0"

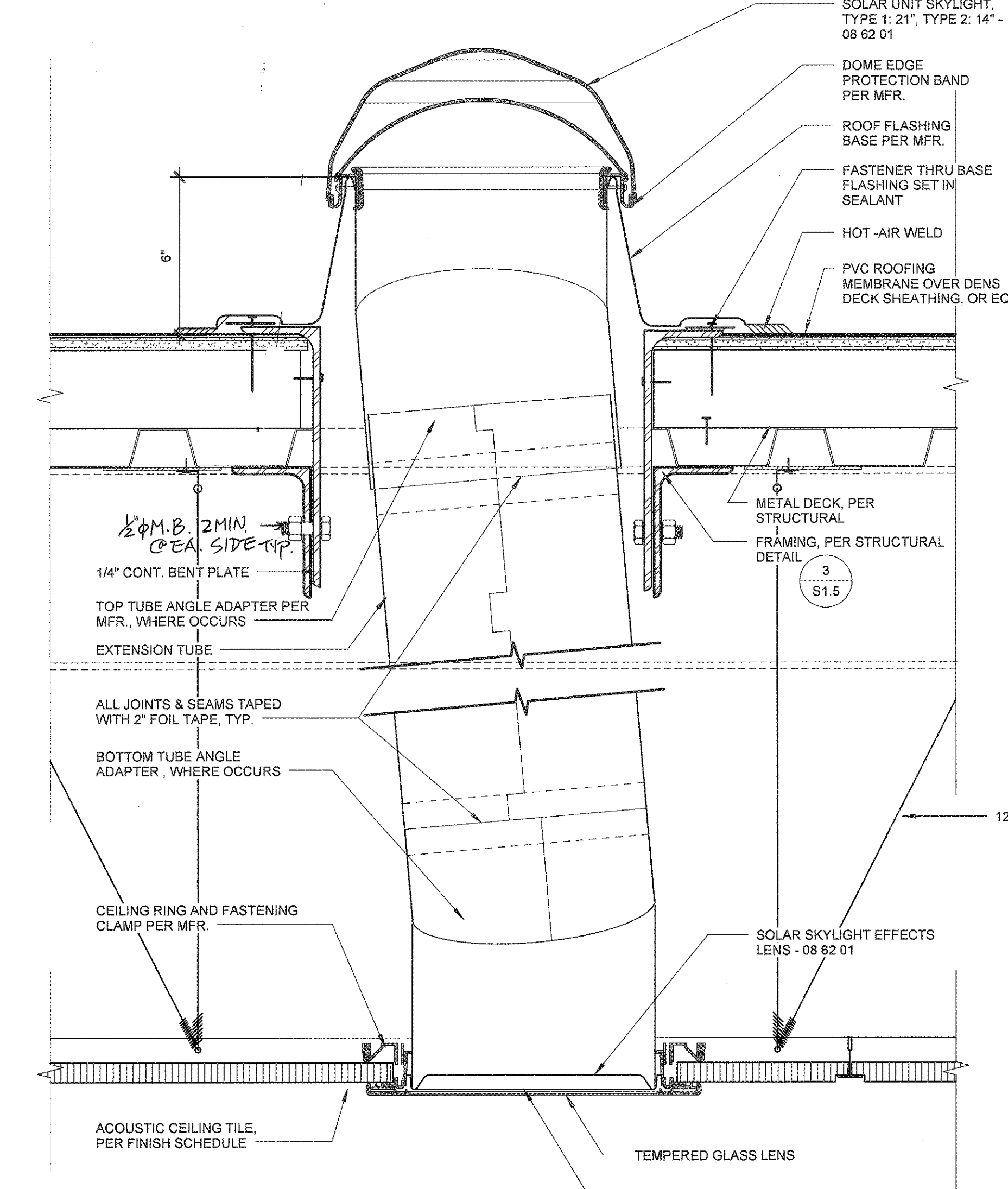

3 TYP. SOLAR SKYLIGHT
 A9.1.1 3" = 1'-0"

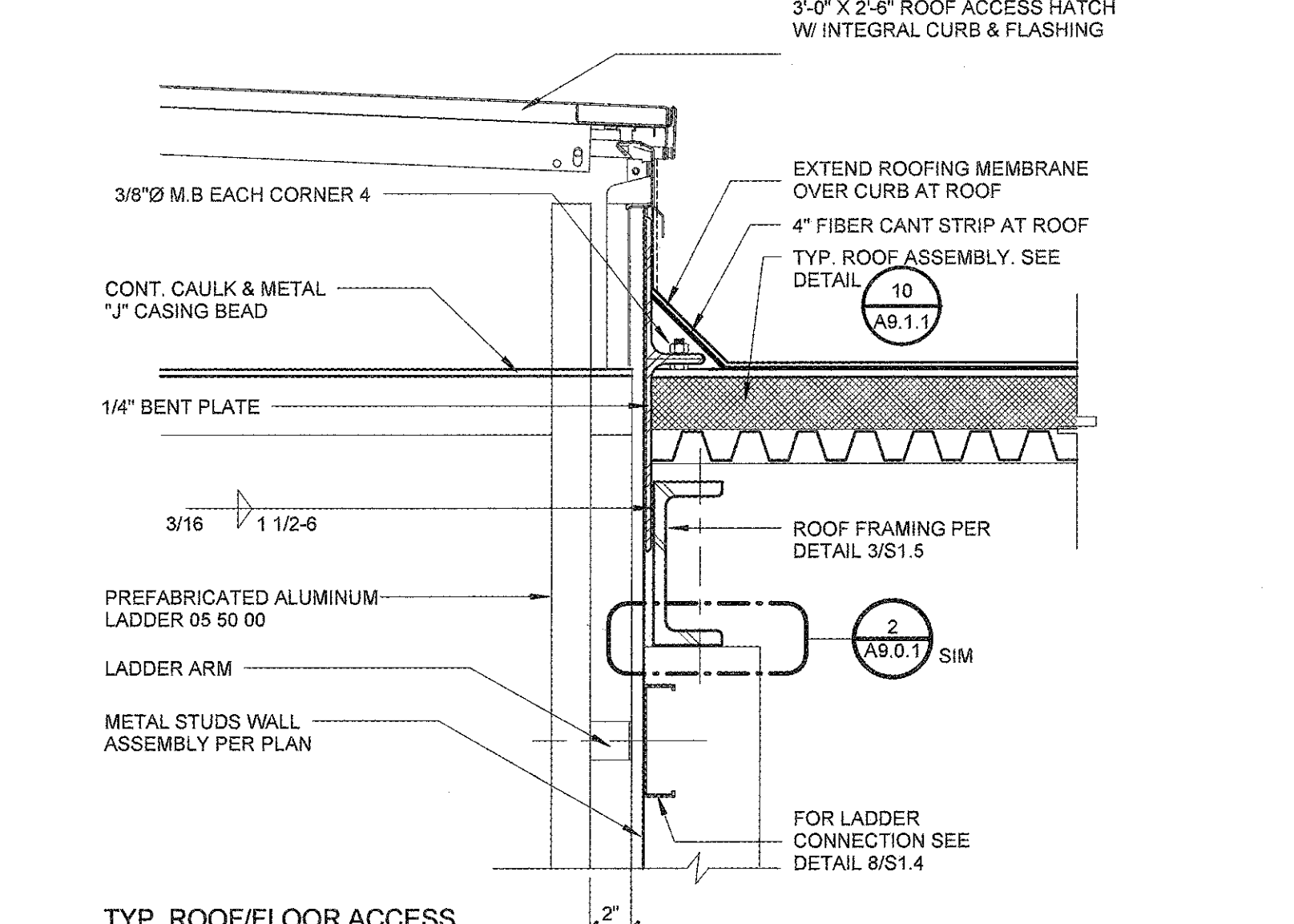

7 TYP. ROOF/FLOOR ACCESS HATCH
 A9.1.1 1 1/2" = 1'-0"

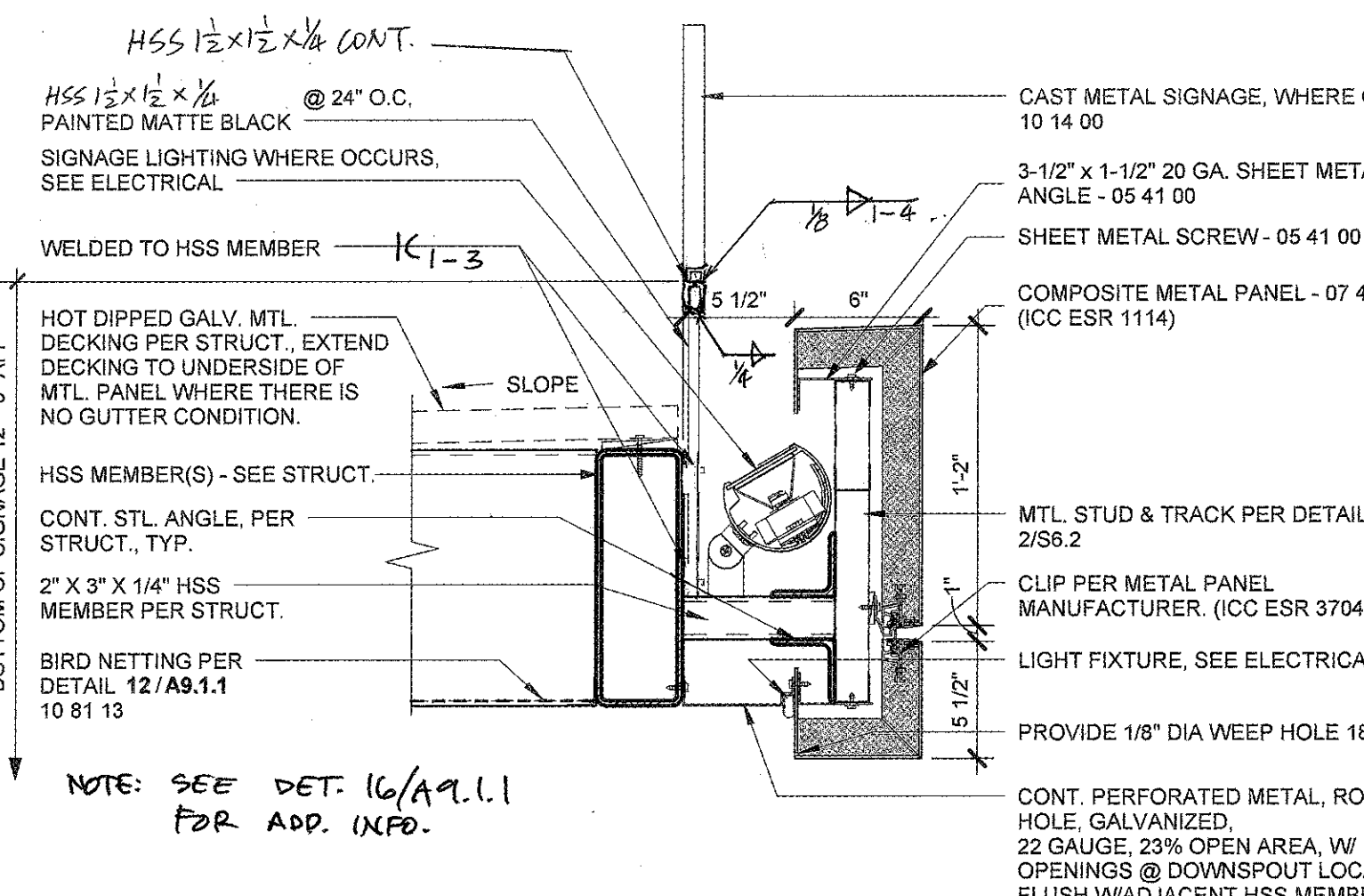

11 SIGNAGE @ CANOPY
 A9.1.1 1 1/2" = 1'-0"

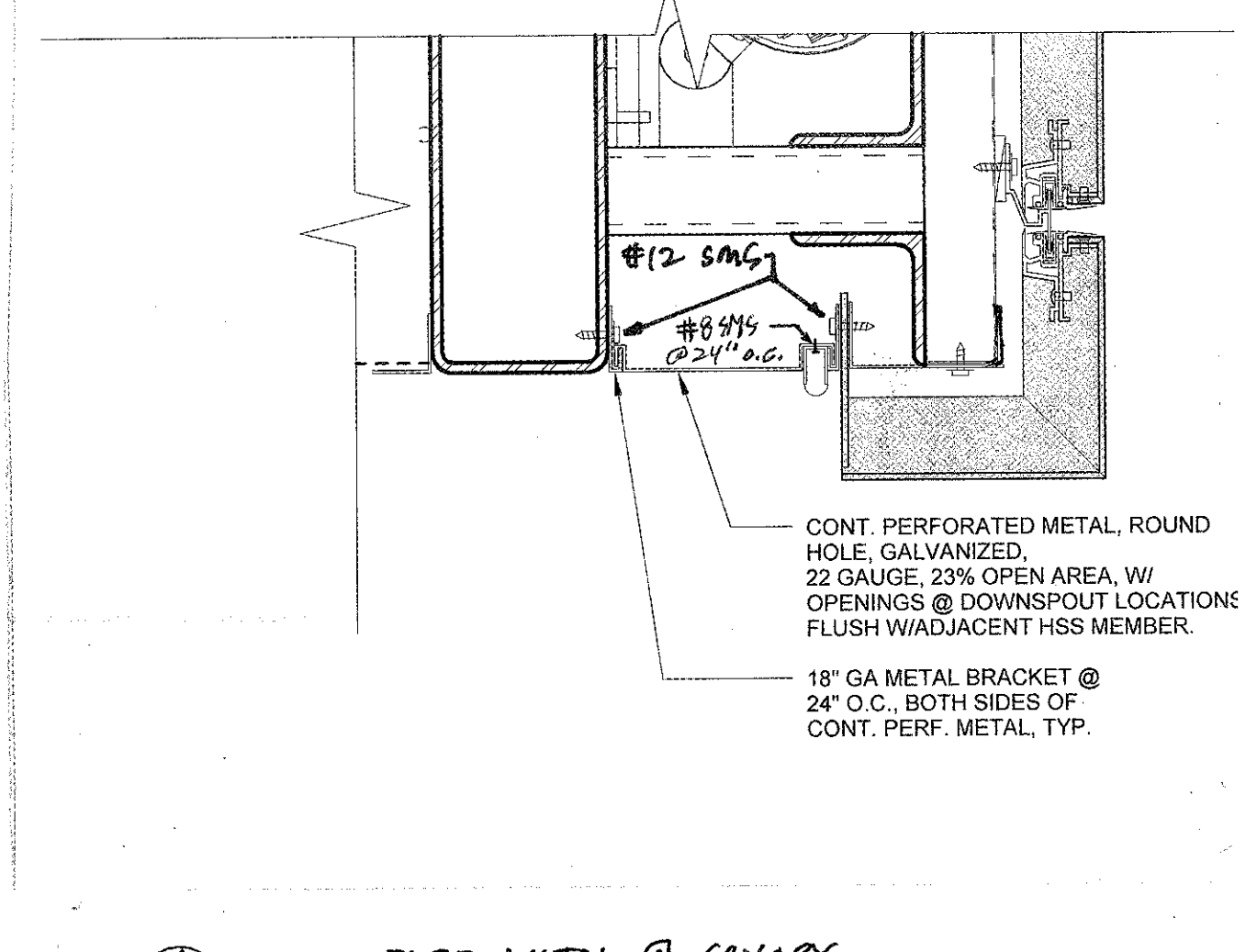

16 CONT. PERF. METAL @ CANOPY
 A9.1.1 NTS.

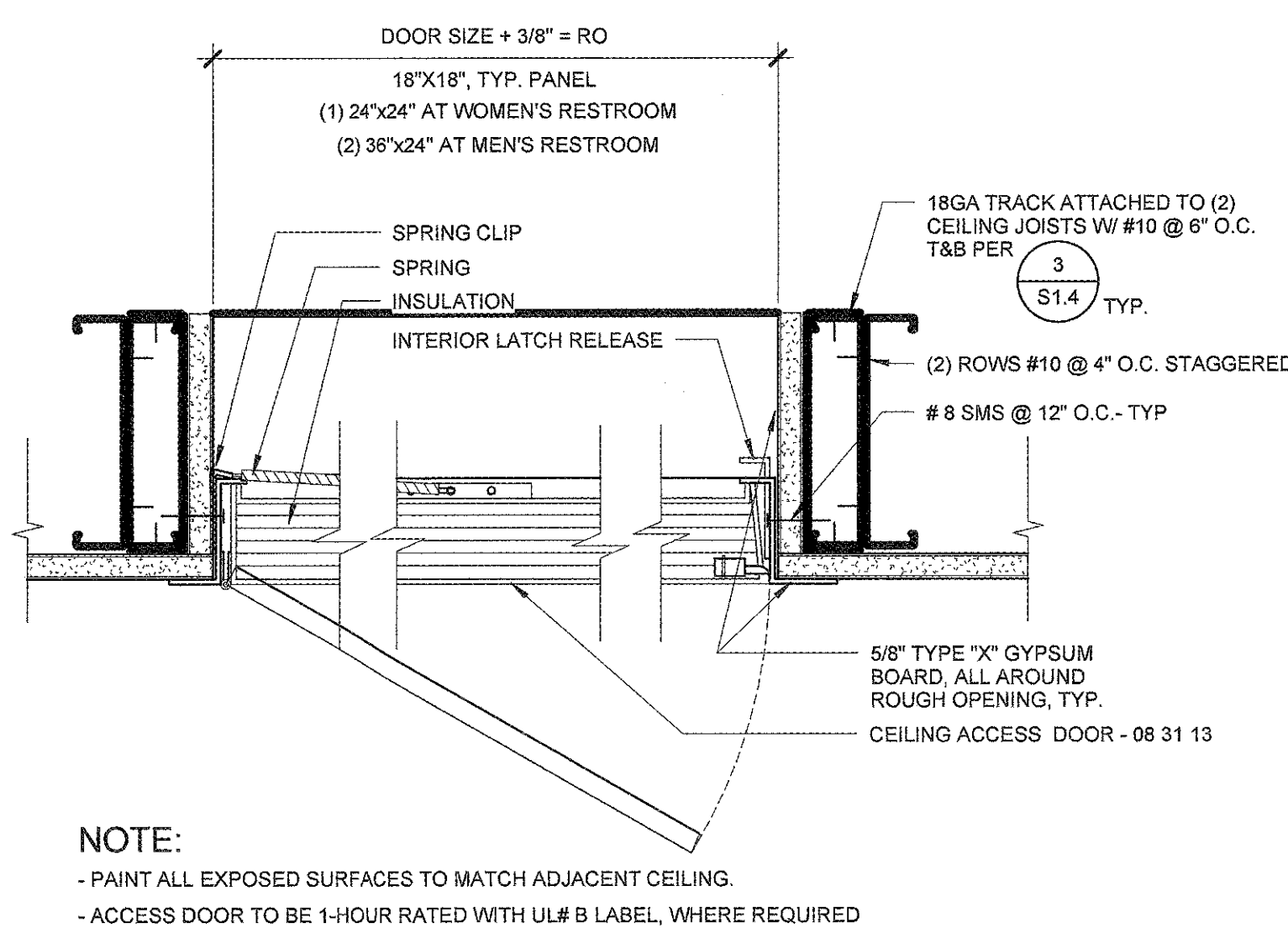

13 TYP. ACCESS PANEL AT FRAMED CEILING
9\"/>

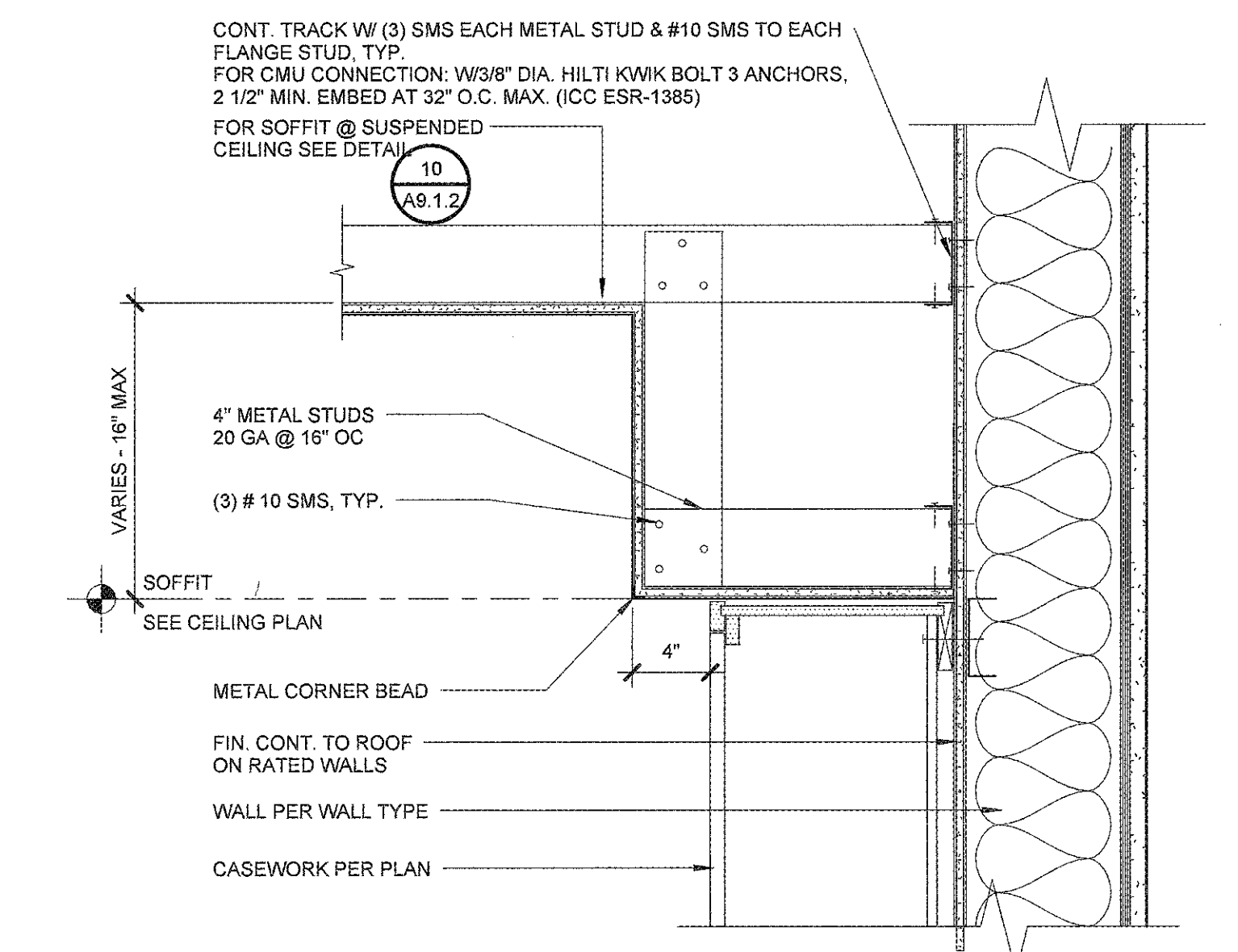

9 TYP. SOFFIT AT UPPER CASEWORK
1 1/2\"/>

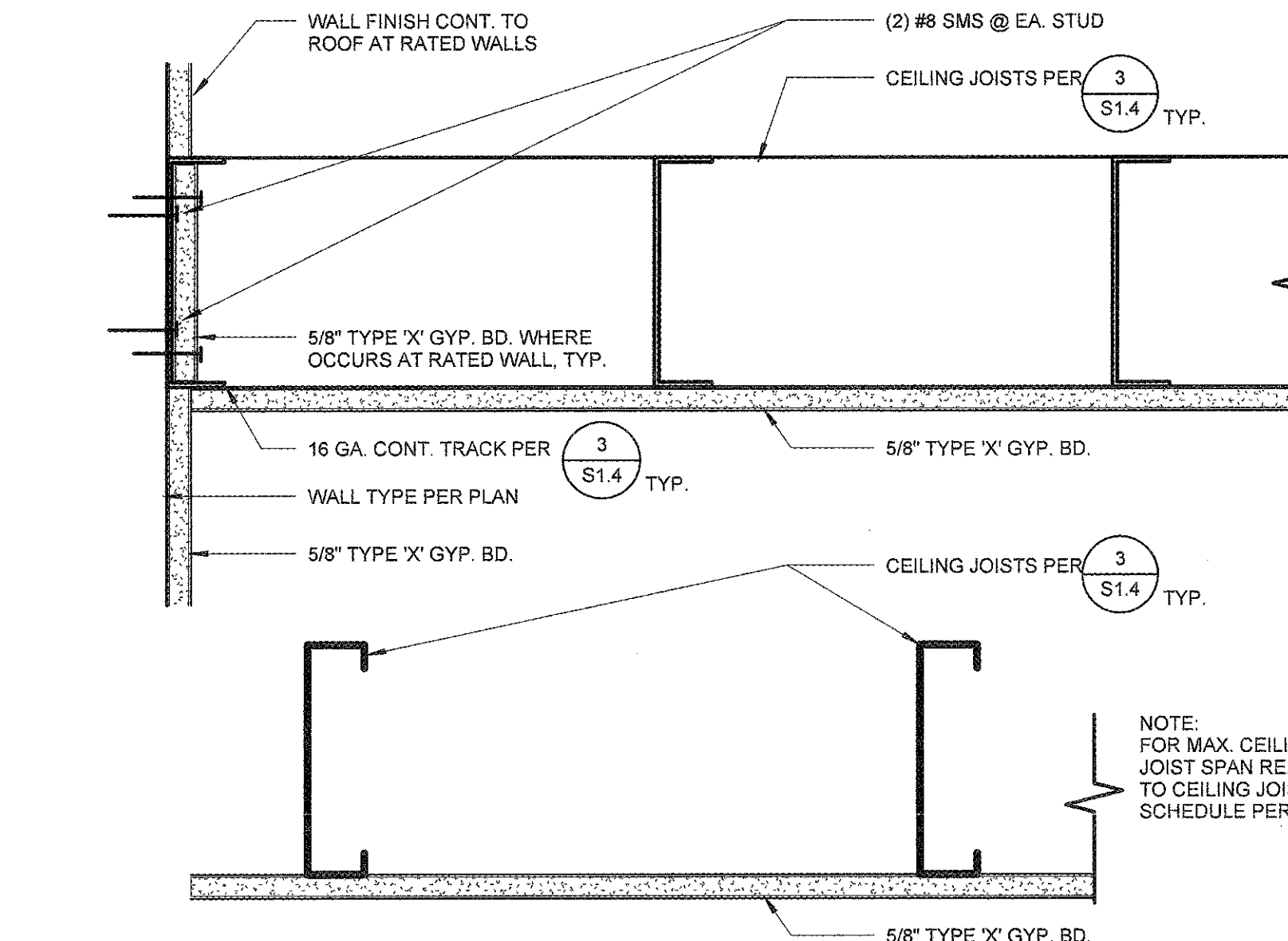

5 TYP. FRAMED GYPSUM BOARD CEILING
9\"/>

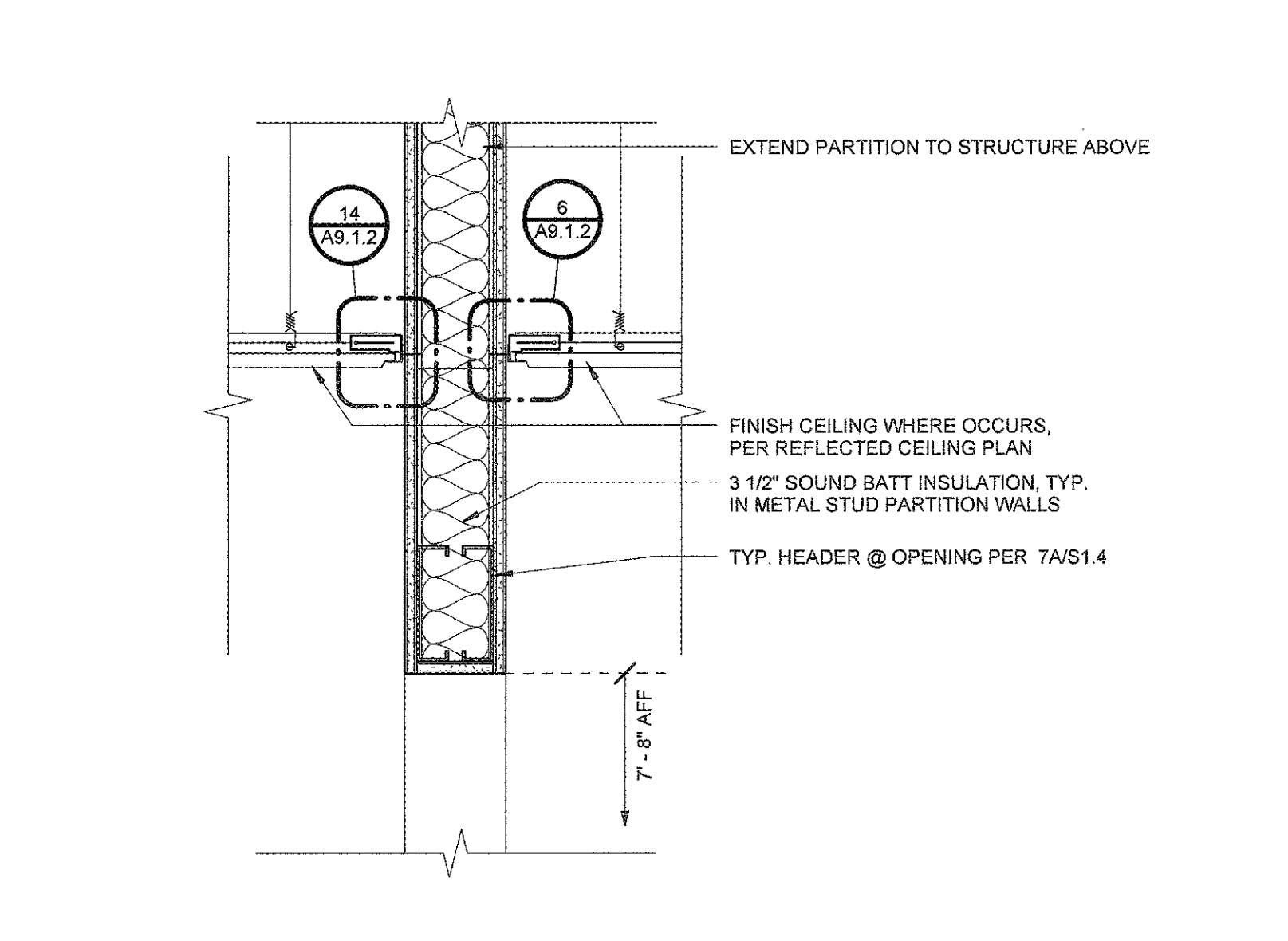

1 HEADER @ OPEN OFFICE & MAIN HALLWAY
1 1/2\"/>

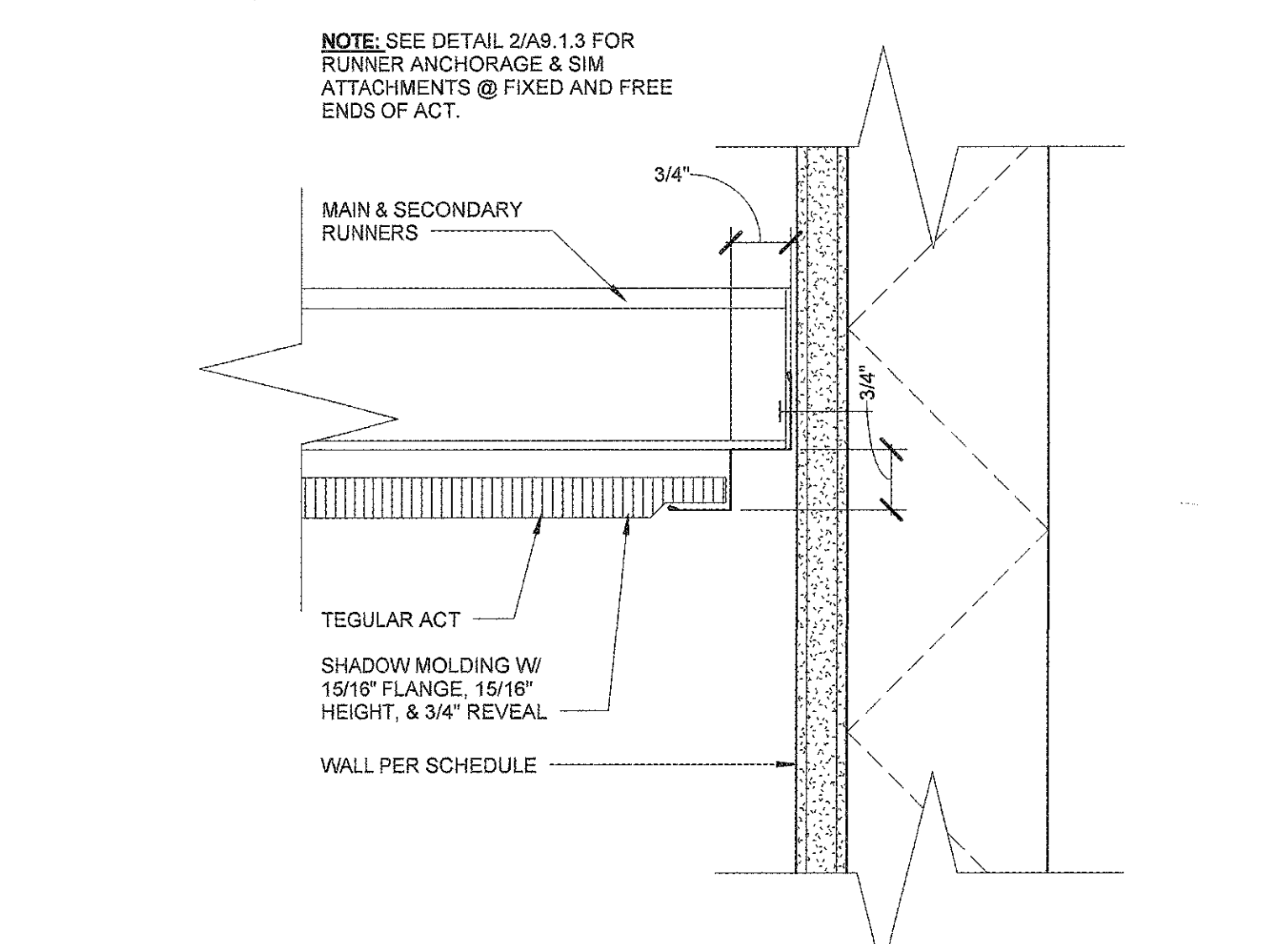

14 ACT SHADOW MOLDING
6\"/>

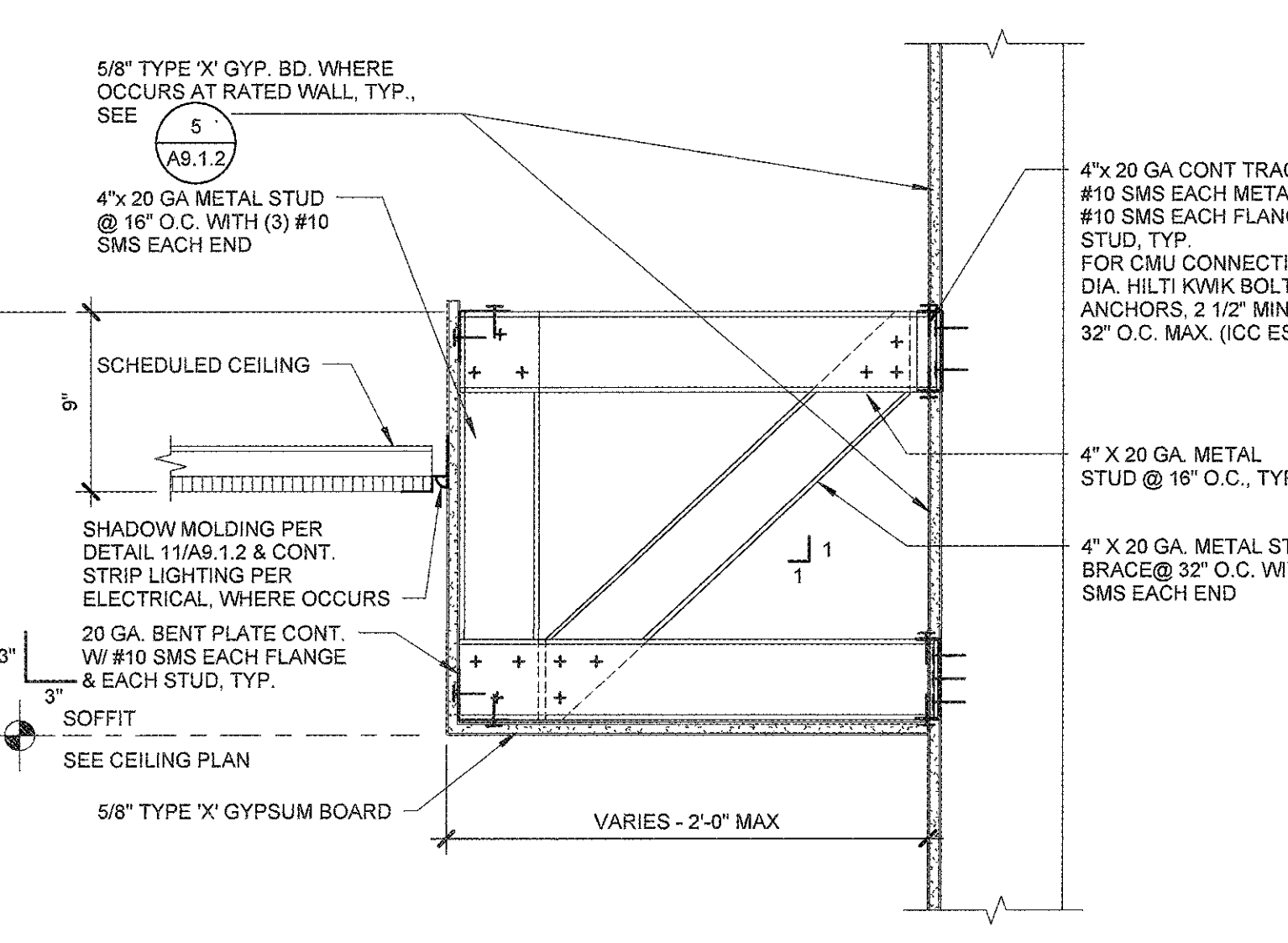

9 TYP. SOFFIT AT SUSPENDED CEILING
1 1/2\"/>

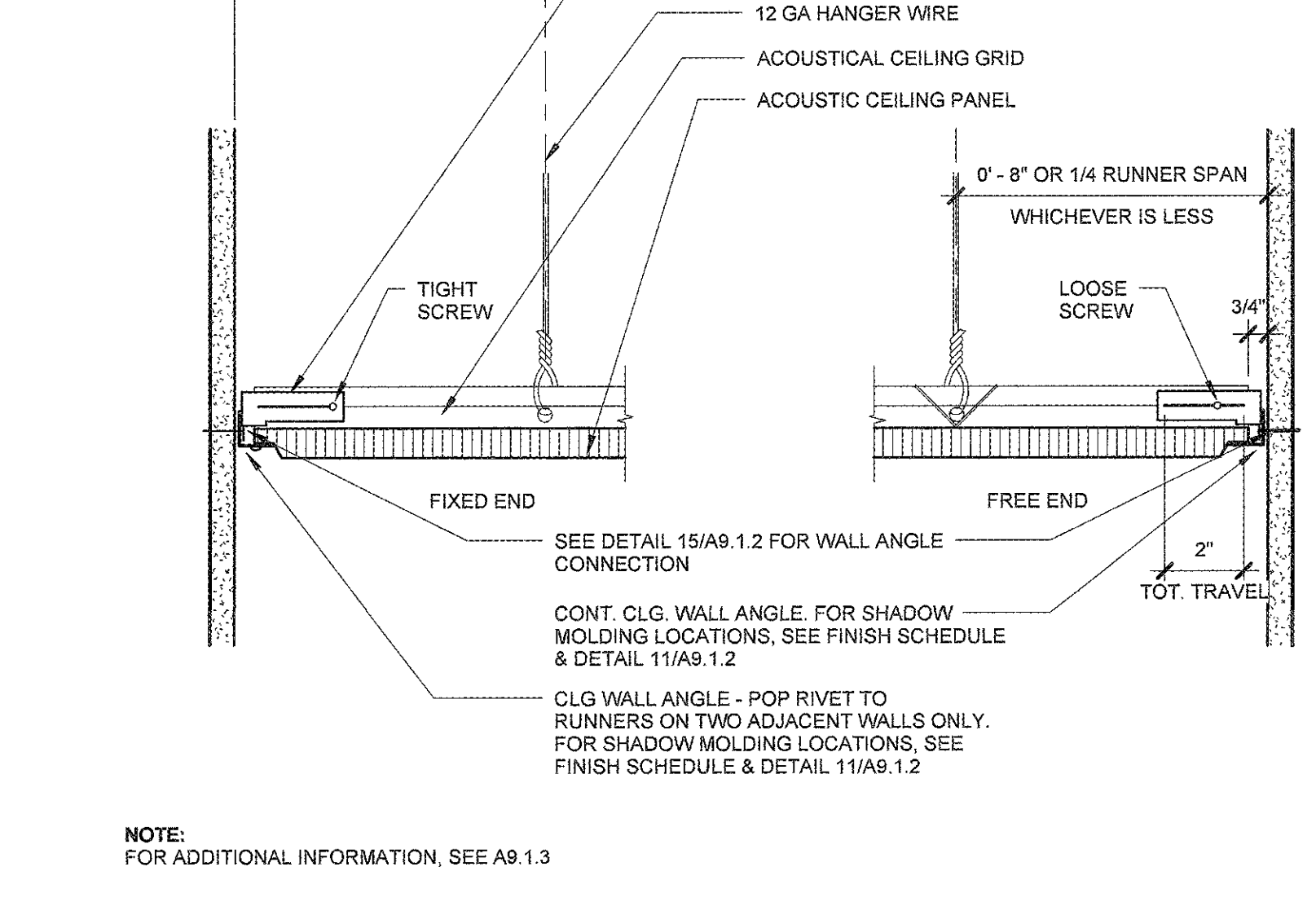

5 TYP. SUSPENDED ACOUSTICAL CEILING
9\"/>

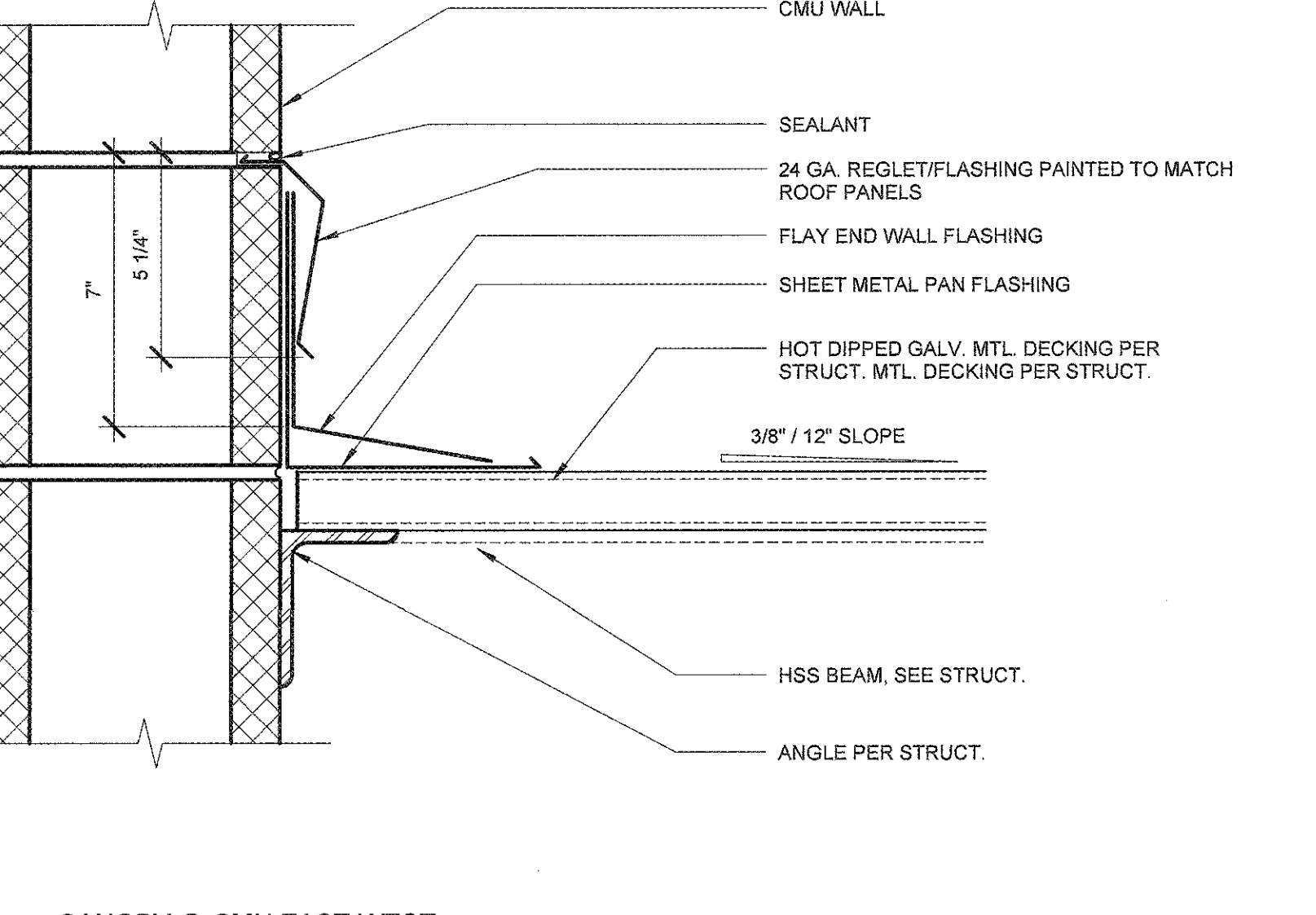

1 CANOPY @ CMU EAST-WEST WALLS
9\"/>

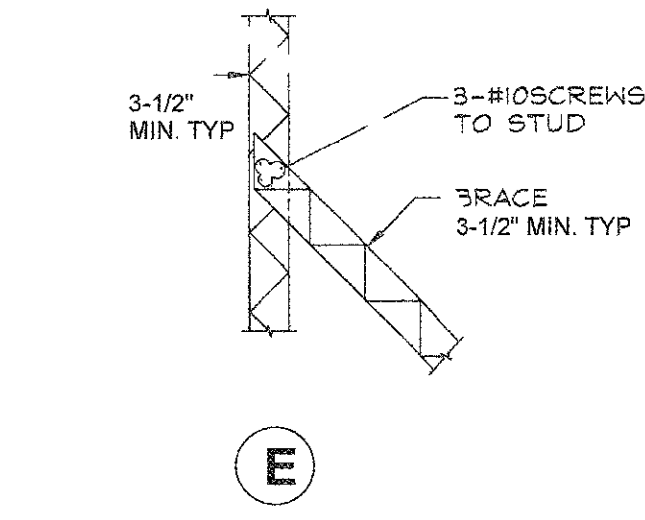

E TYP. CEILING AND SOFFIT CONNECTION DETAILS
3 1/2\"/>



10 TYP. SOFFIT AT SUSPENDED CEILING
1 1/2\"/>

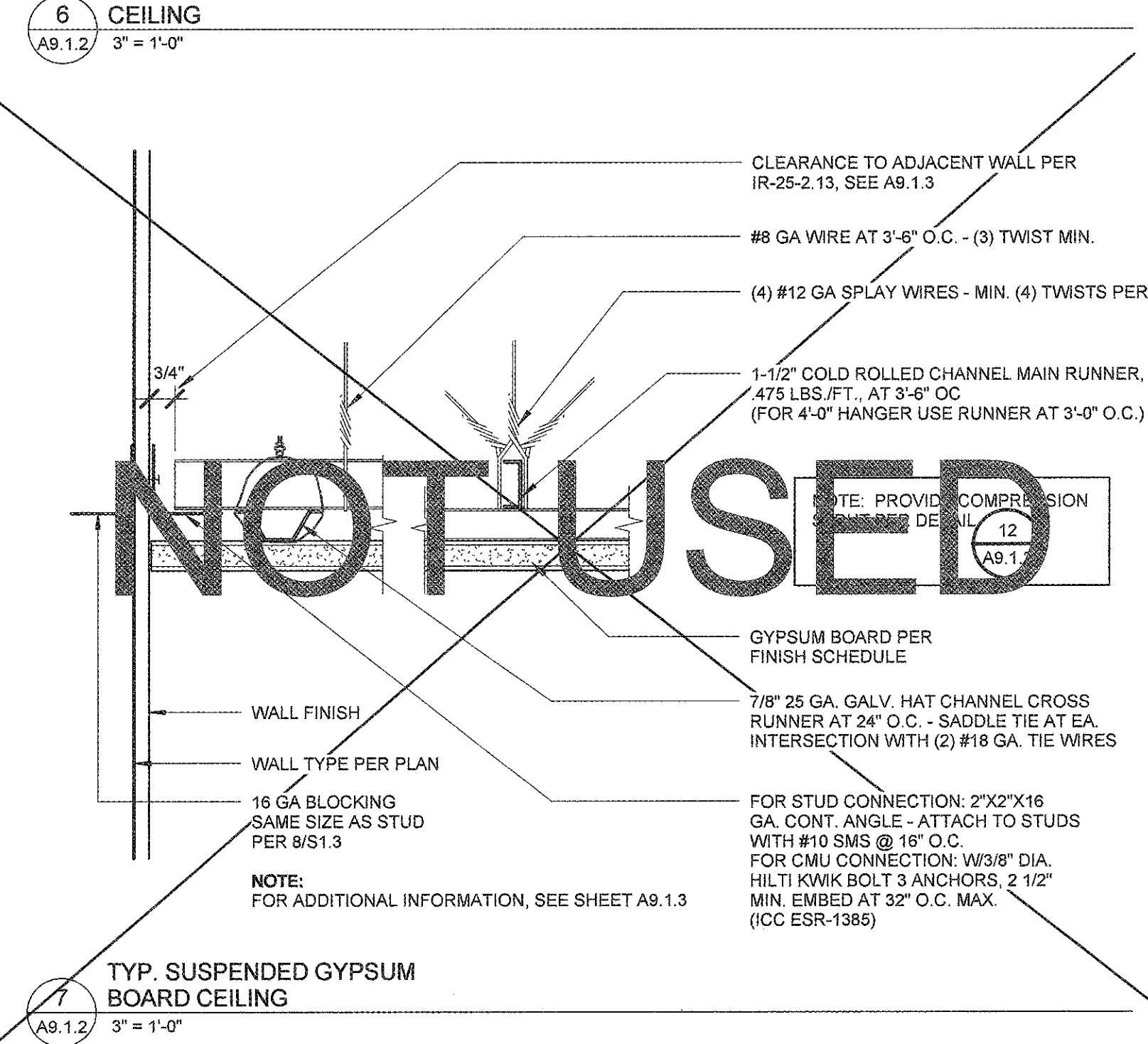

6 TYP. SUSPENDED GYPSUM BOARD CEILING
9\"/>

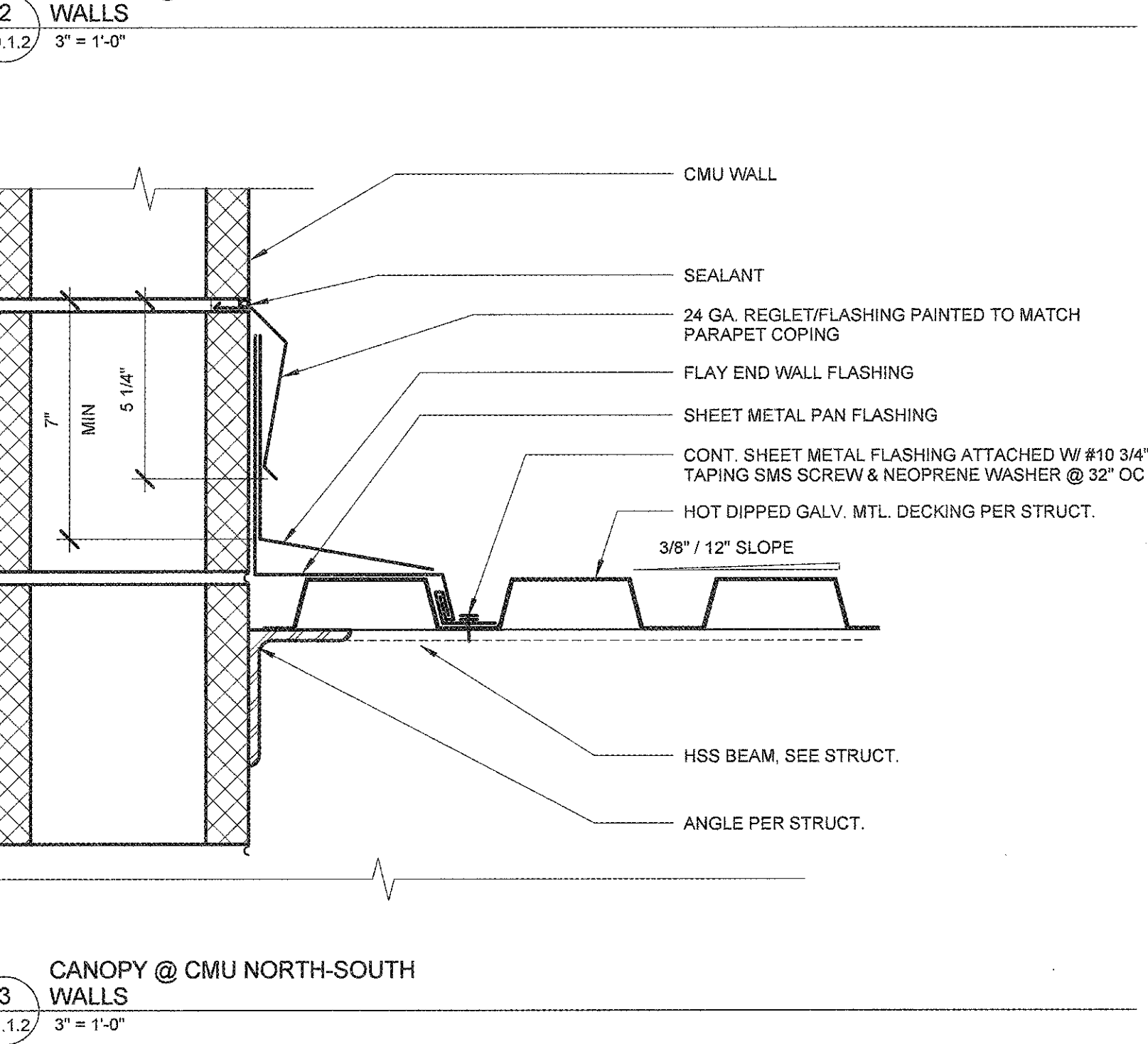

2 CANOPY @ CMU NORTH-SOUTH WALLS
9\"/>

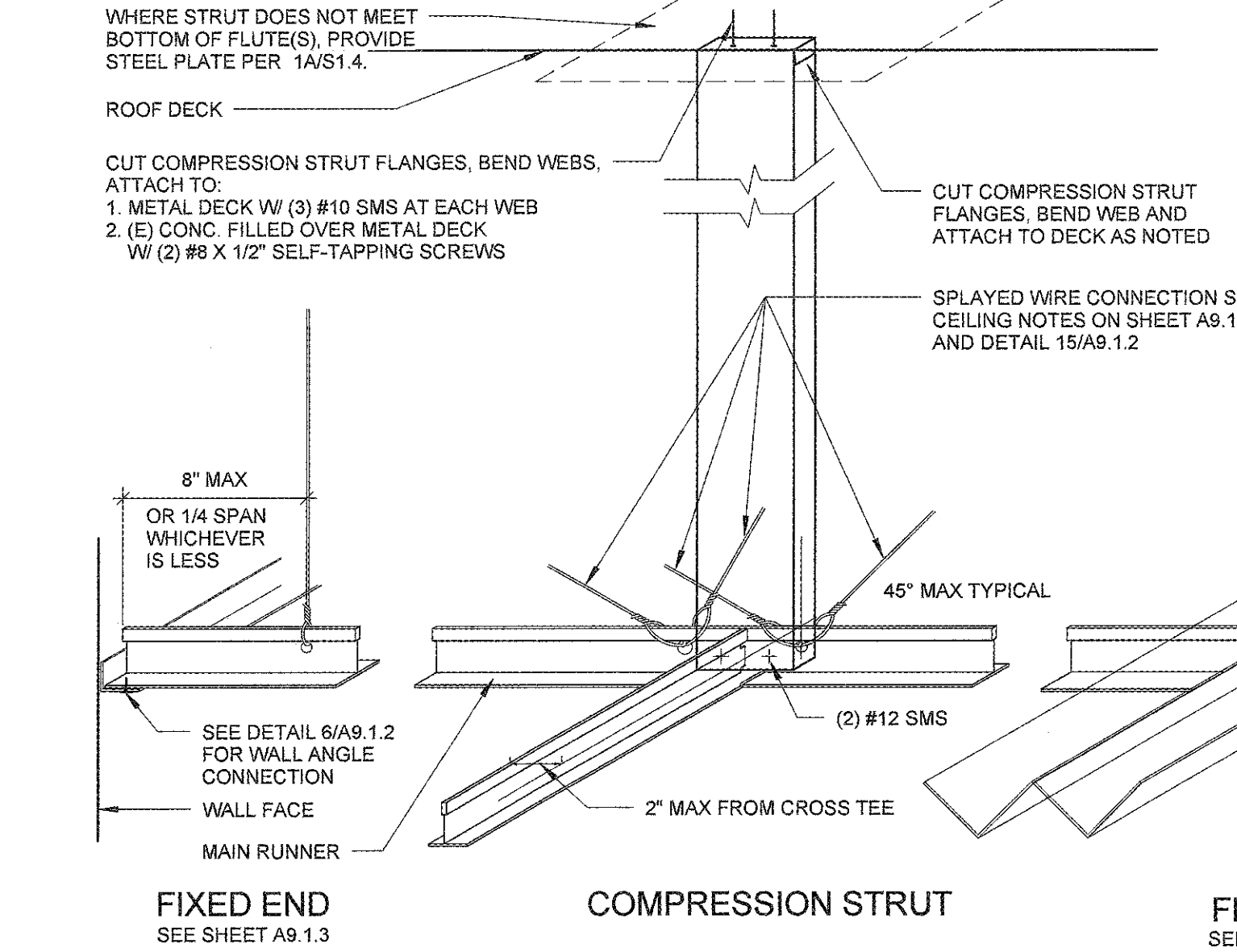

12 TYP. CEILING COMPRESSION STRUT
9\"/>

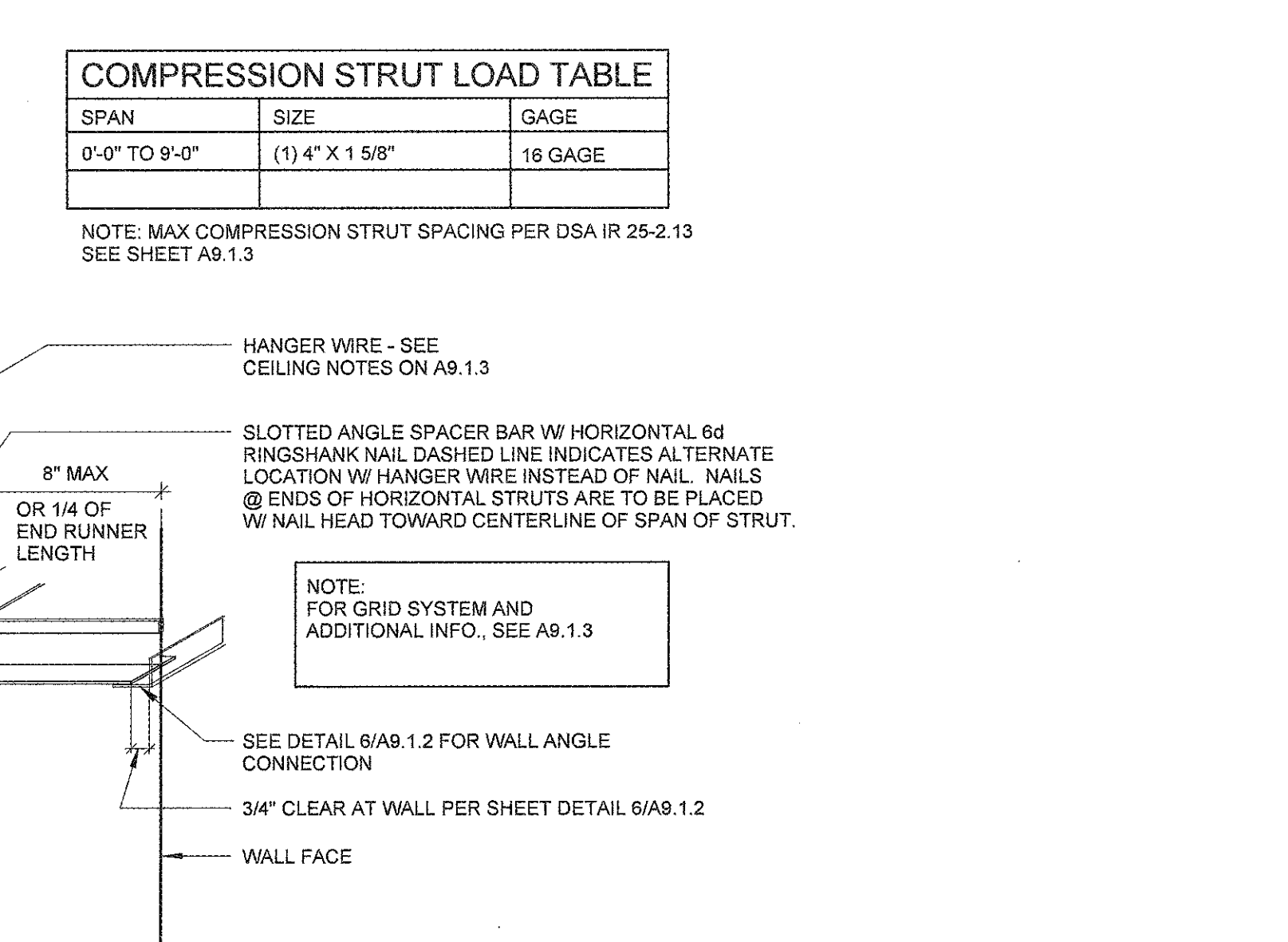

7 TYP. SUSPENDED GYPSUM BOARD CEILING
9\"/>

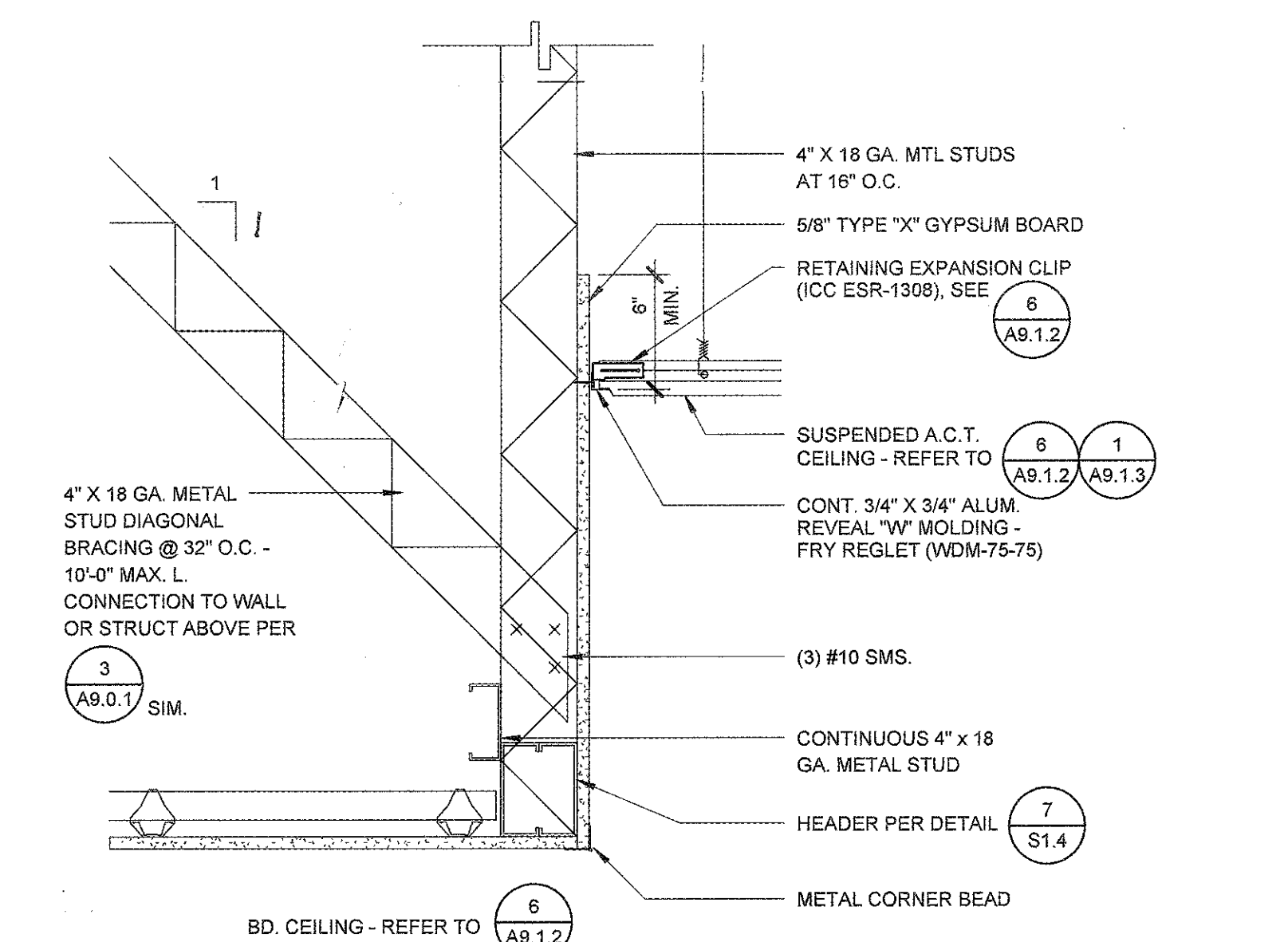

3 CANOPY @ CMU NORTH-SOUTH WALLS
9\"/>

COMPRESSION STRUT LOAD TABLE

SPAN	SIZE	GAGE
0'-0\"/>	(1) 4\"/>	16 GAGE

NOTE: MAX COMPRESSION STRUT SPACING PER DSA-IR 25-2.13 SEE SHEET A9.1.3

NOT USED

LITTLE
DEVELOPED ARCHITECTURAL CONSULTING

1300 Dove Street, Suite 100
Newport Beach, CA 92660
T: 949.698.1400 F: 949.698.1433
www.littleonline.com

This drawing and the design shown are the property of Little Developed Architectural Consulting. The reproduction, copying or other use of this drawing without their written consent is prohibited and any infringement will be subject to legal action.

© Little 2016

COMPTON CCD

PROJECT NAME
CAMPUS PUBLIC SAFETY BUILDING

1111 EAST ARTESIA BOULEVARD,
COMPTON CALIFORNIA 90221

IDENTIFICATION STAMP
DIV. OF THE STATE ARCHITECT
OFFICE OF REGULATION SERVICES

FILE NO: 19-C1
AE: 03-117673

AC: [Signature] FLS: [Signature] SS: [Signature] P: [Signature]
DATE: DEC. 12, 2017

PROFESSIONAL IN CHARGE
RITA S. CARTER
PROJECT MANAGER
SHOJI TAKESHIMA / DAVID PHAN
DRAWN BY
DAVID PHAN

NO REASON DATE

REGISTERED ARCHITECT
RITA S. CARTER
NO. C35431
REL. 4-30-19
STATE OF CALIFORNIA

CEILING DETAILS

913-4675-00

12/01/16 A9.1.2

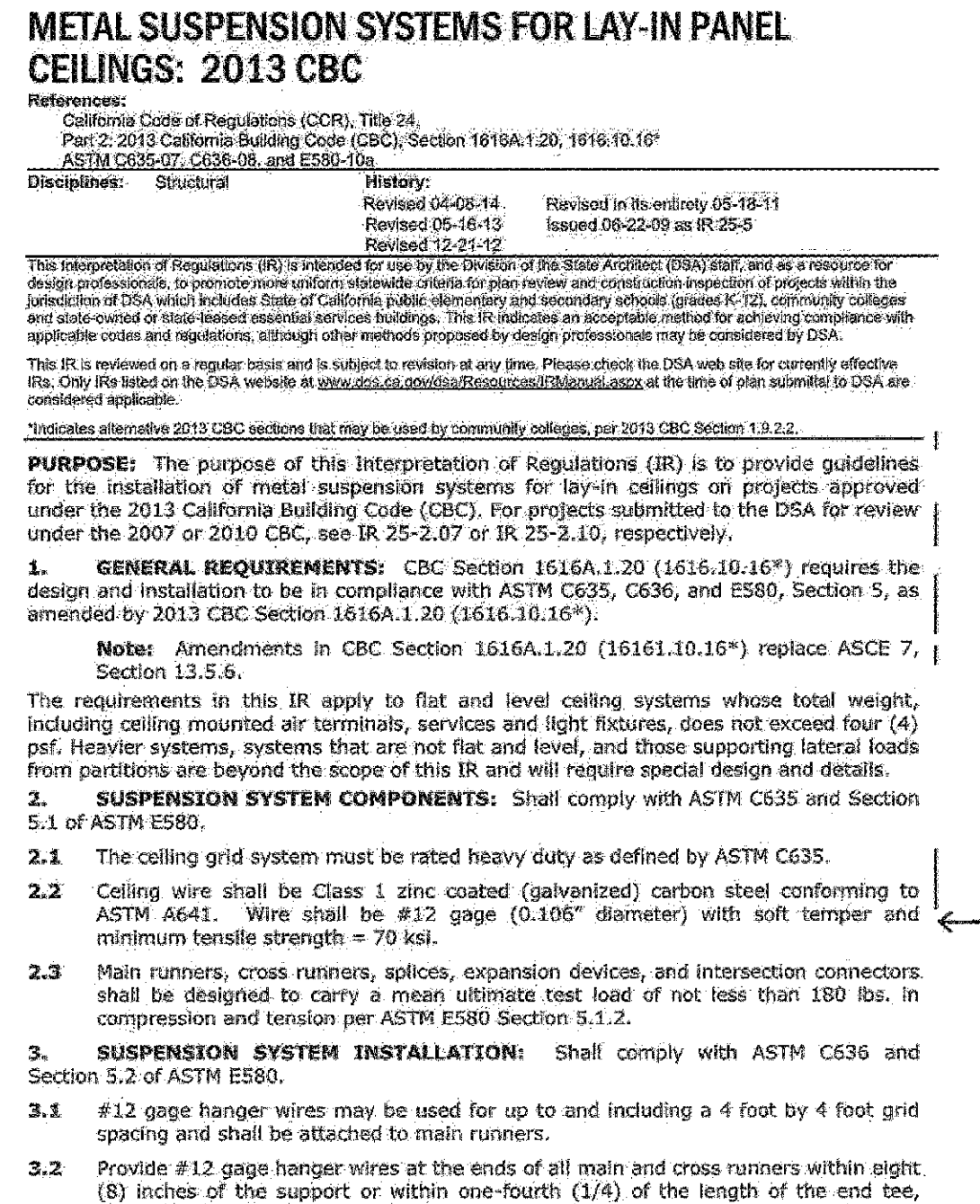
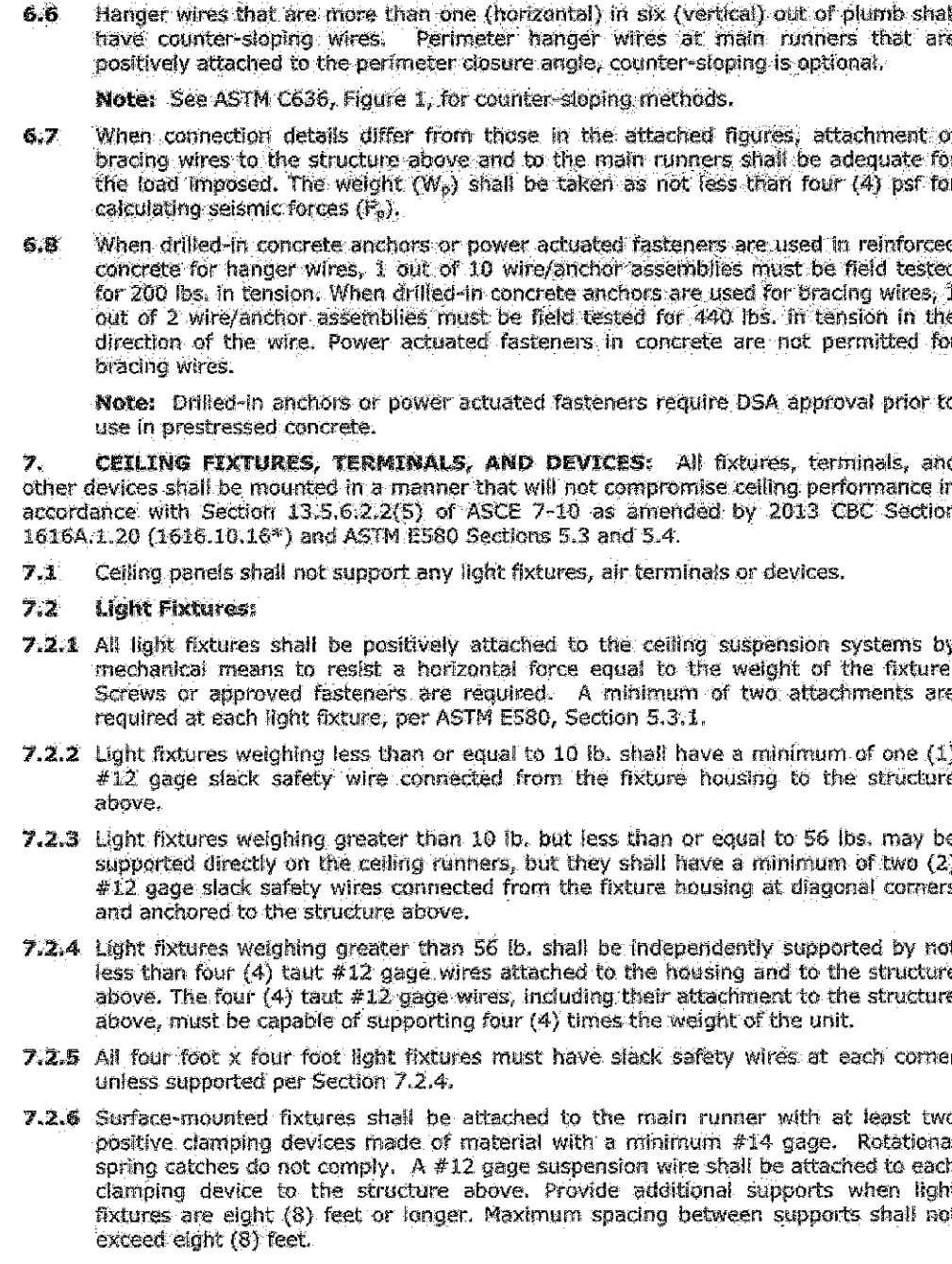
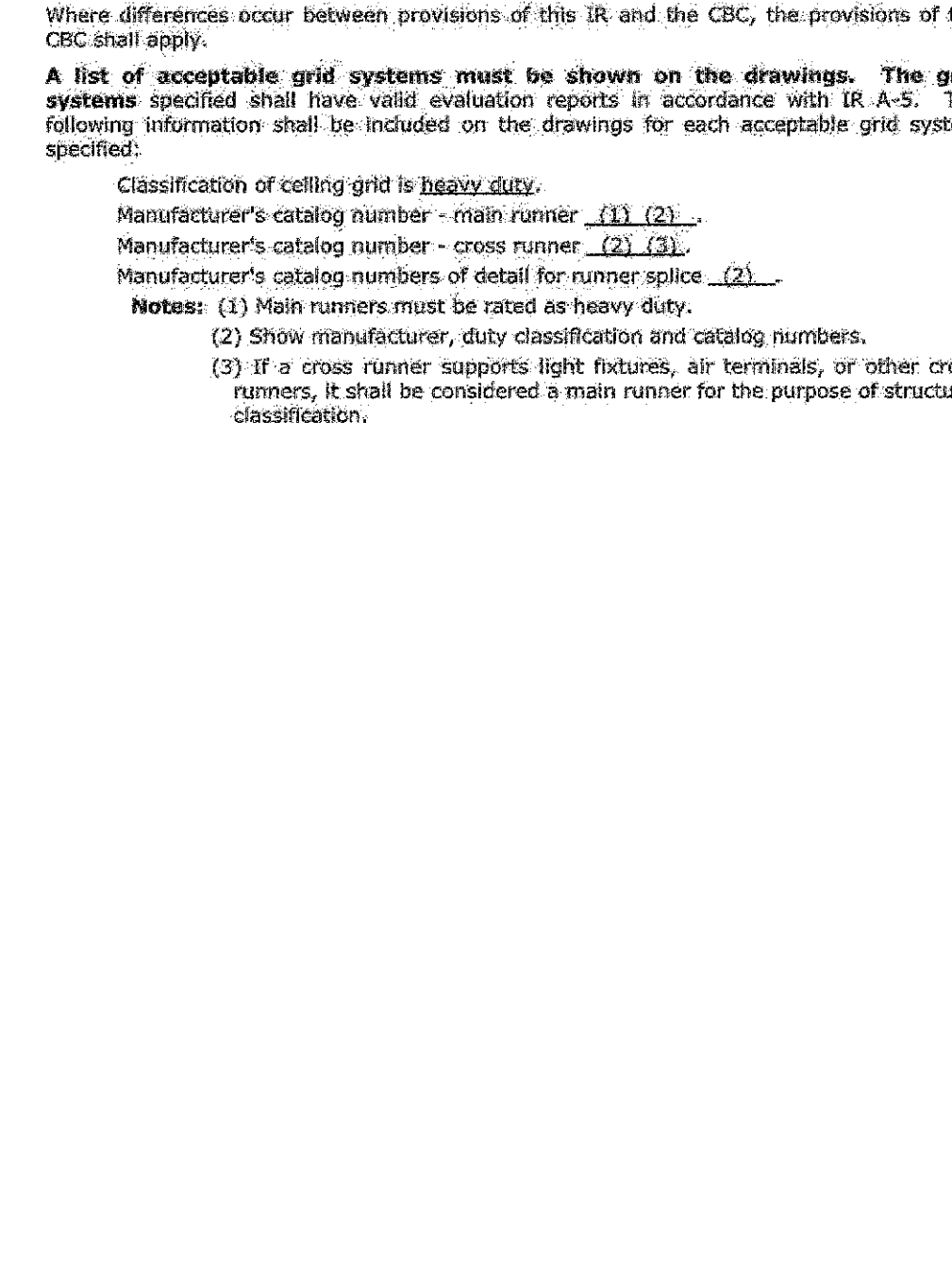
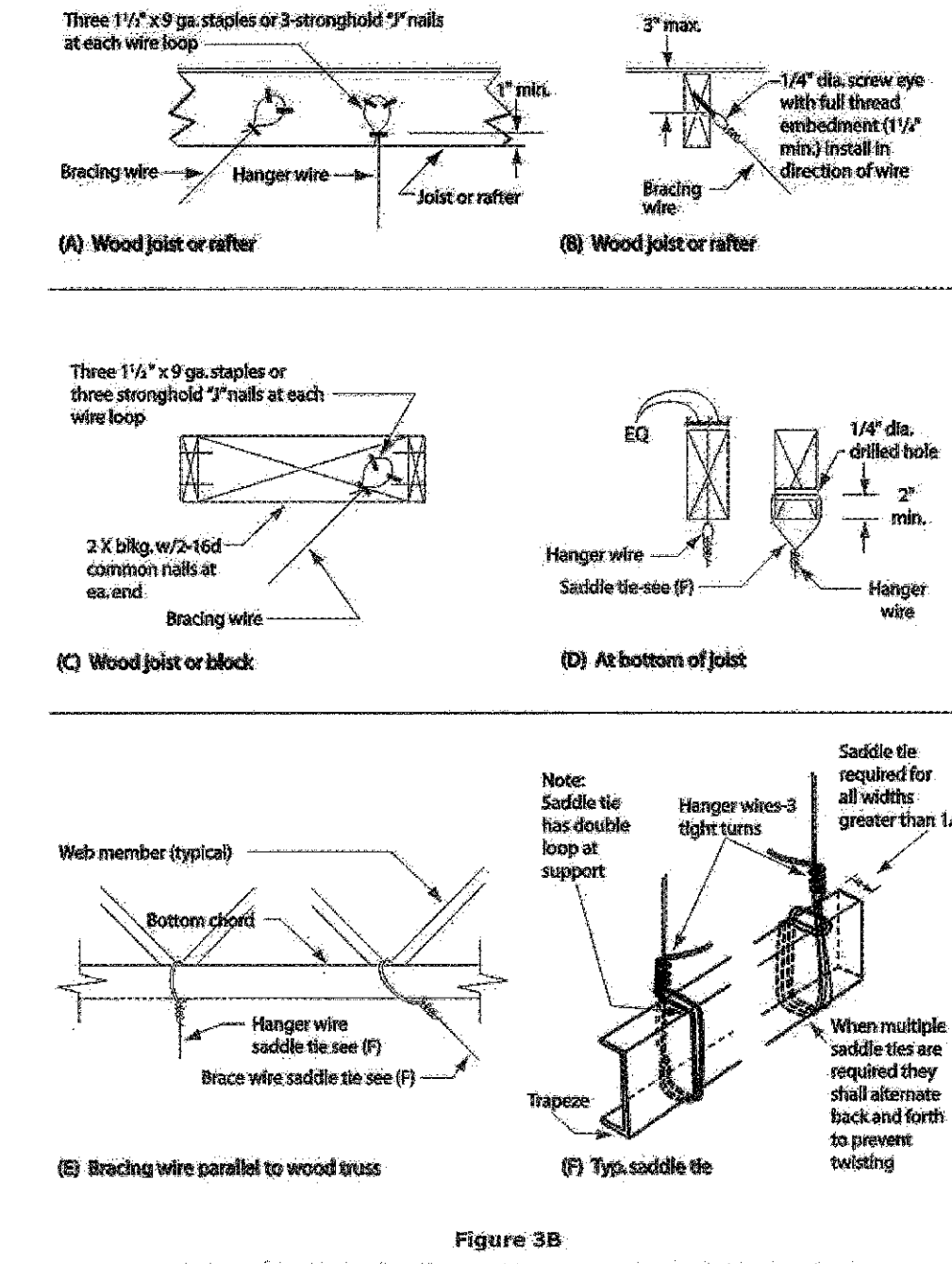
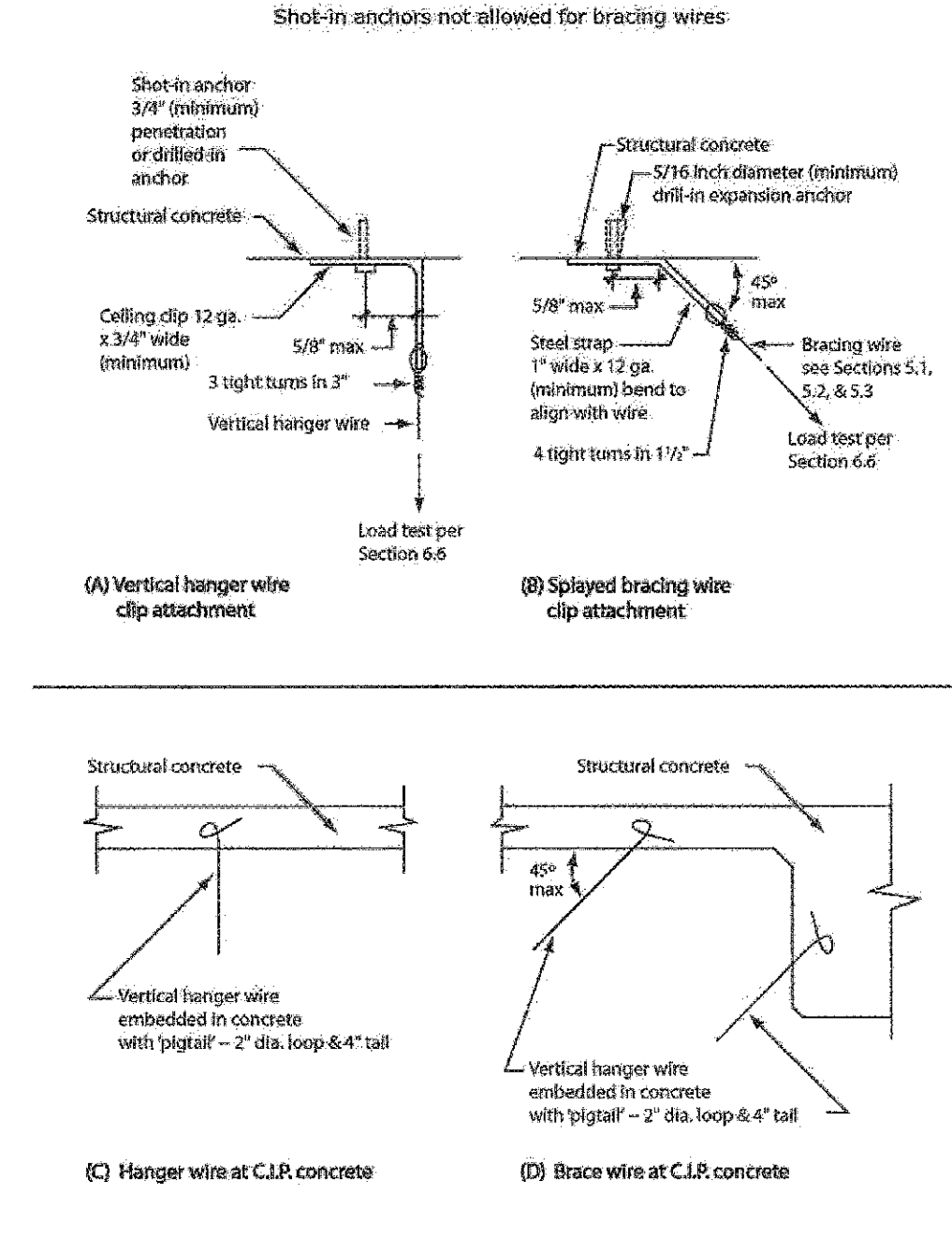
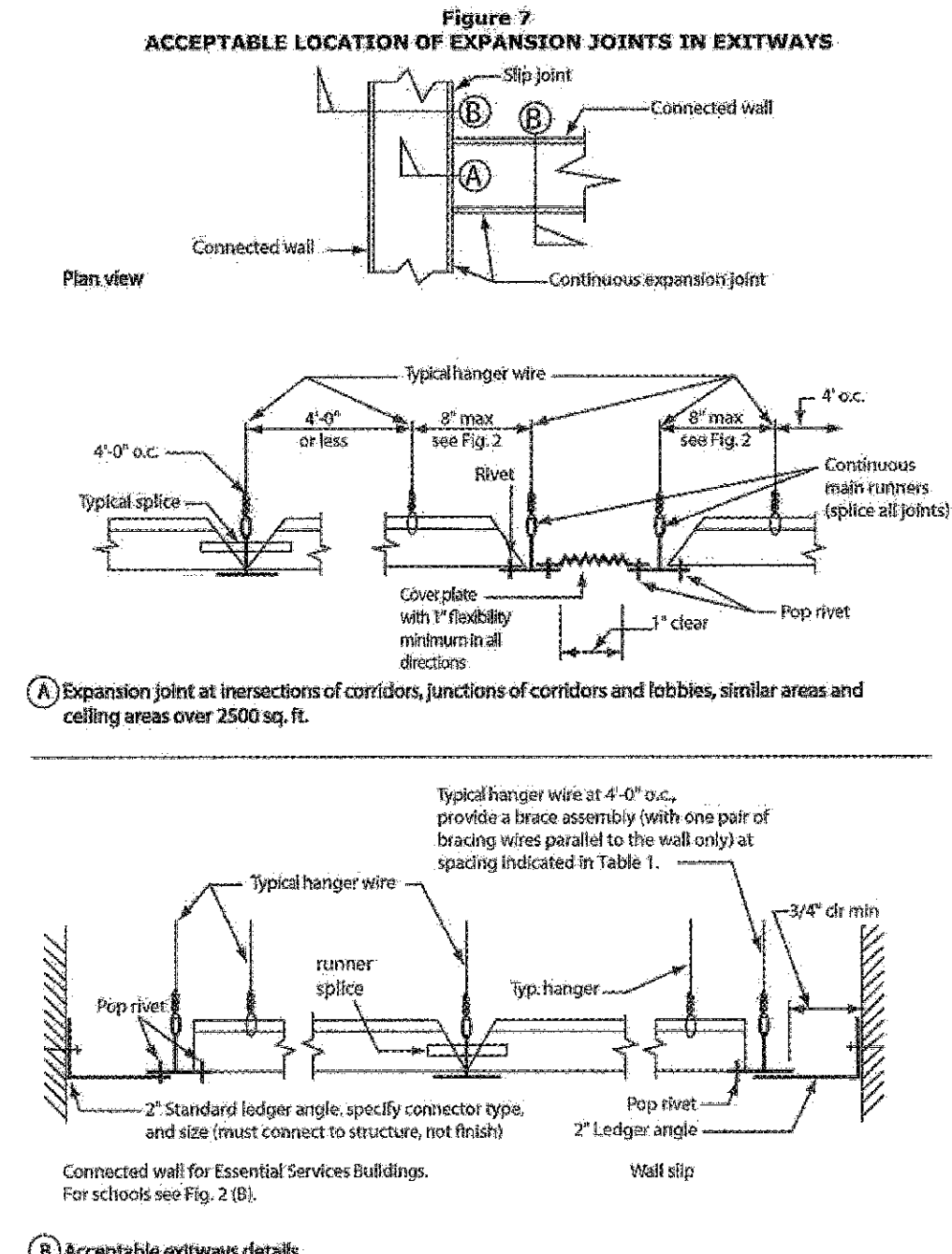

California Department of General Services - Division of the State Architect - Interpretation of Regulations Document
IR 25-1
MAXIMUM ALLOWABLE LOAD FOR 10 GAUGE AND 12 GAUGE WIRES
Revised 08-29-10
Issued 08-01-08 as IR 822
This IR is intended to provide a guide to the Division of the State Architect (DSA) and its users for the design and installation of metal suspension systems for lay-in panel ceilings. It is not intended to be used as a substitute for the design and construction of any specific project. It is intended to provide a guide to the DSA and its users for the design and construction of any specific project. It is not intended to be used as a substitute for the design and construction of any specific project.

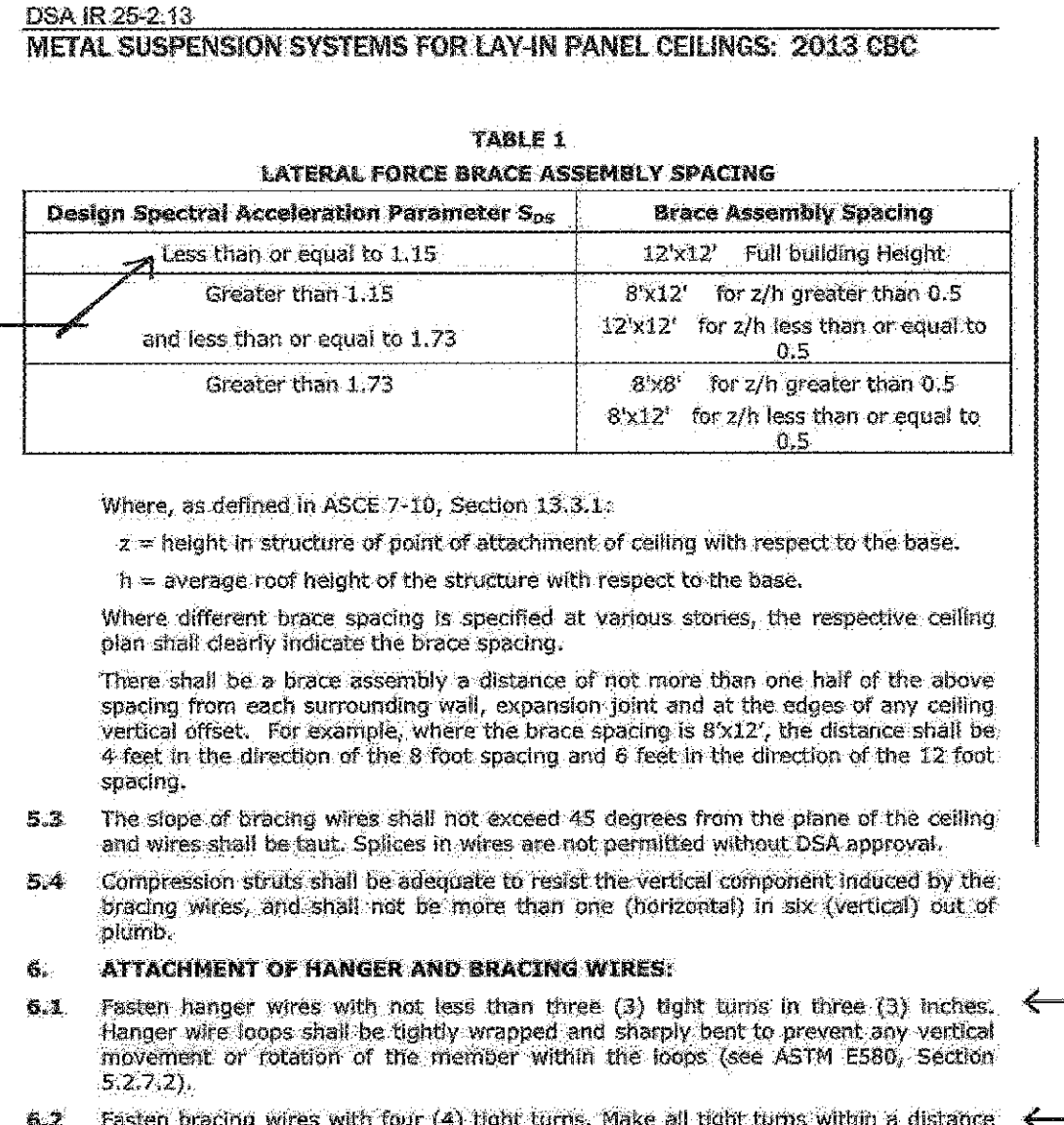
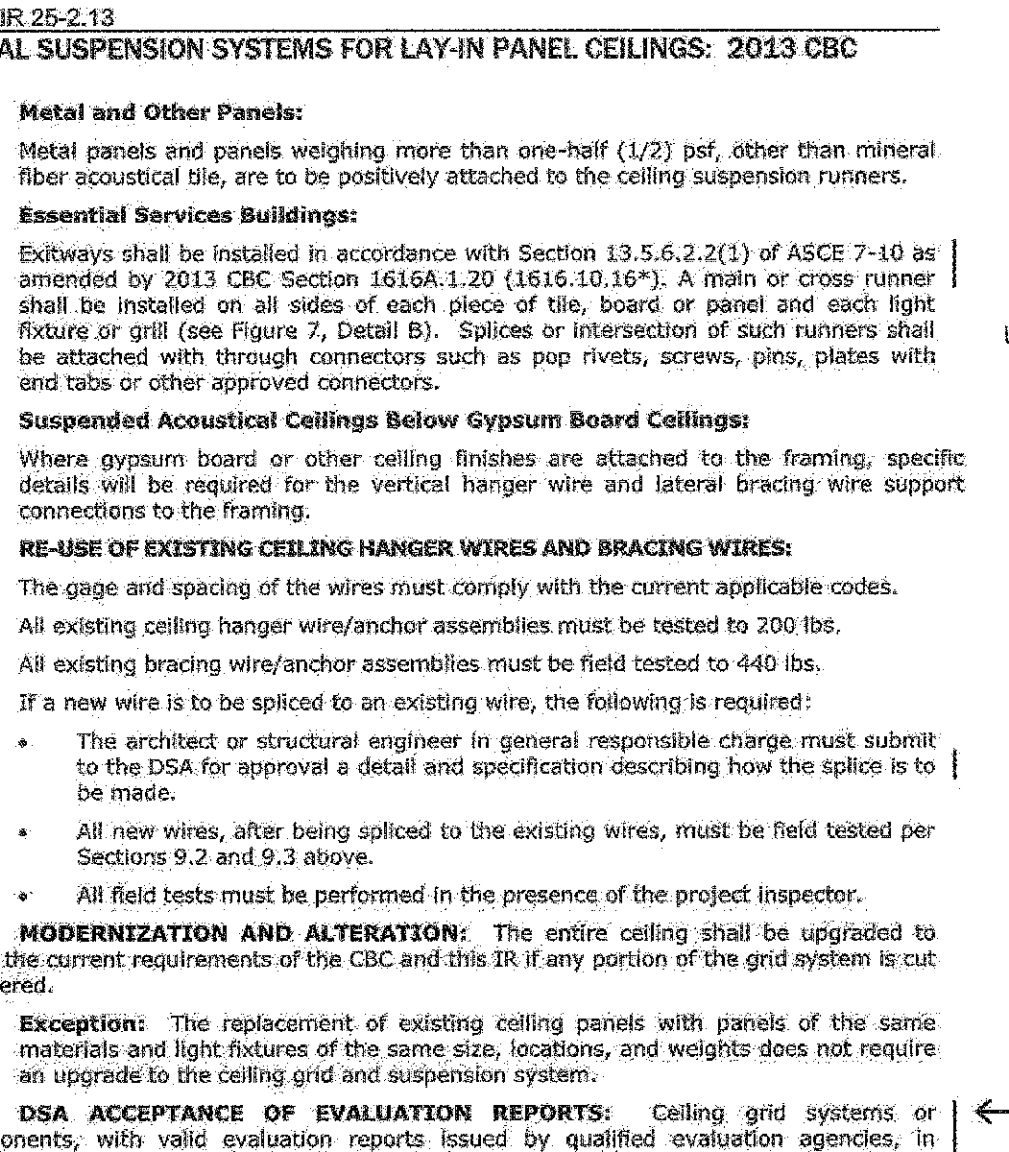
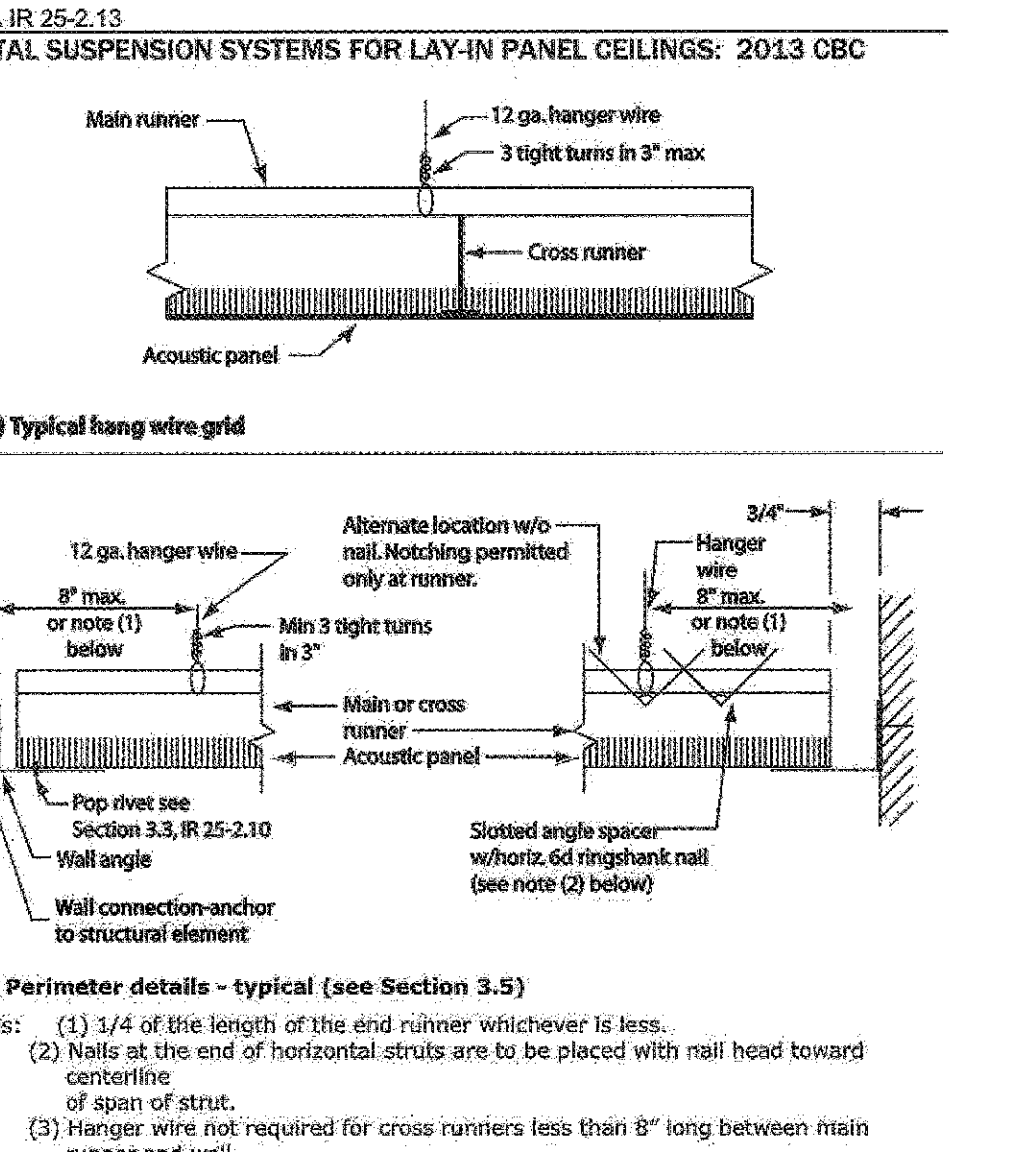
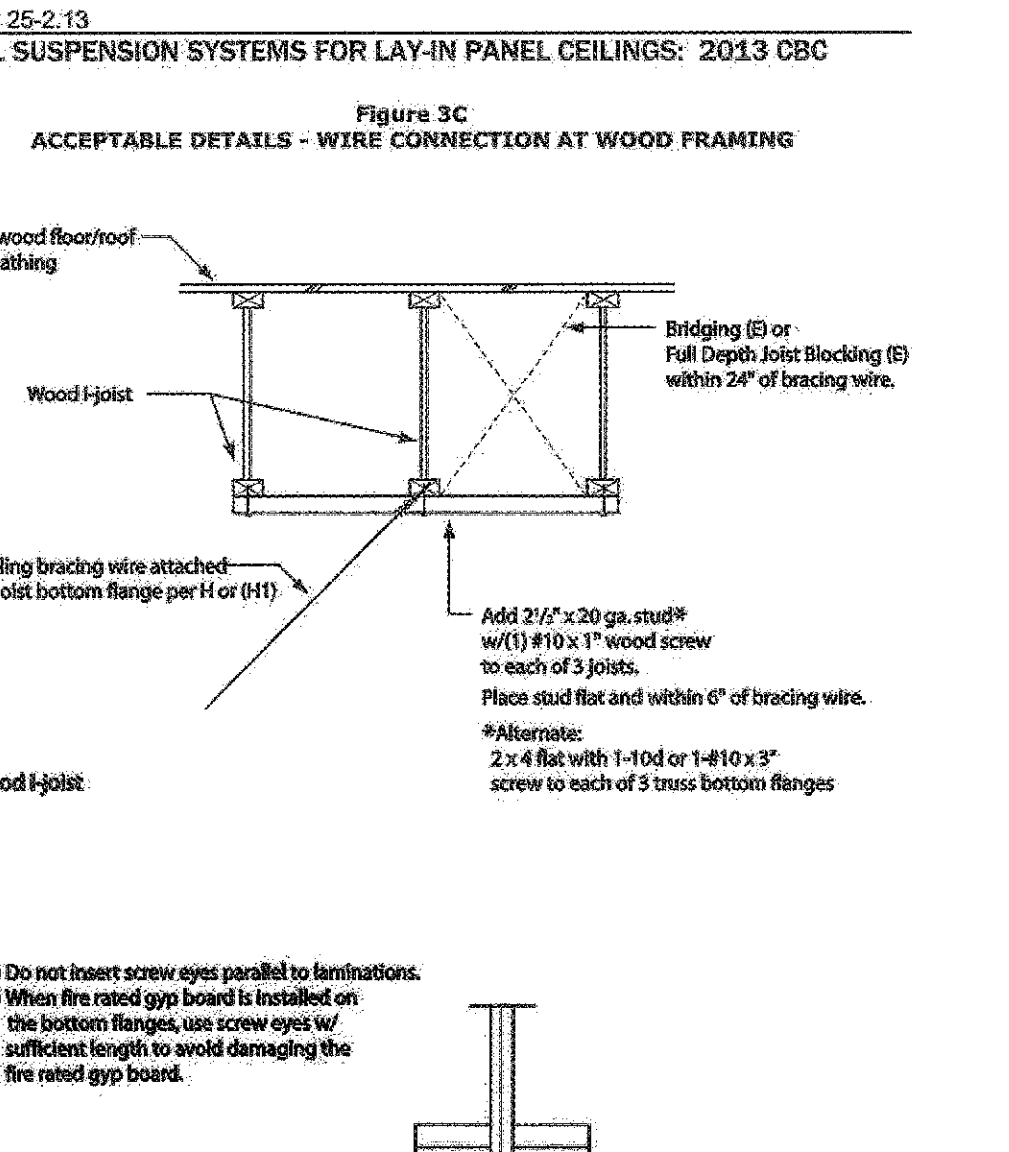
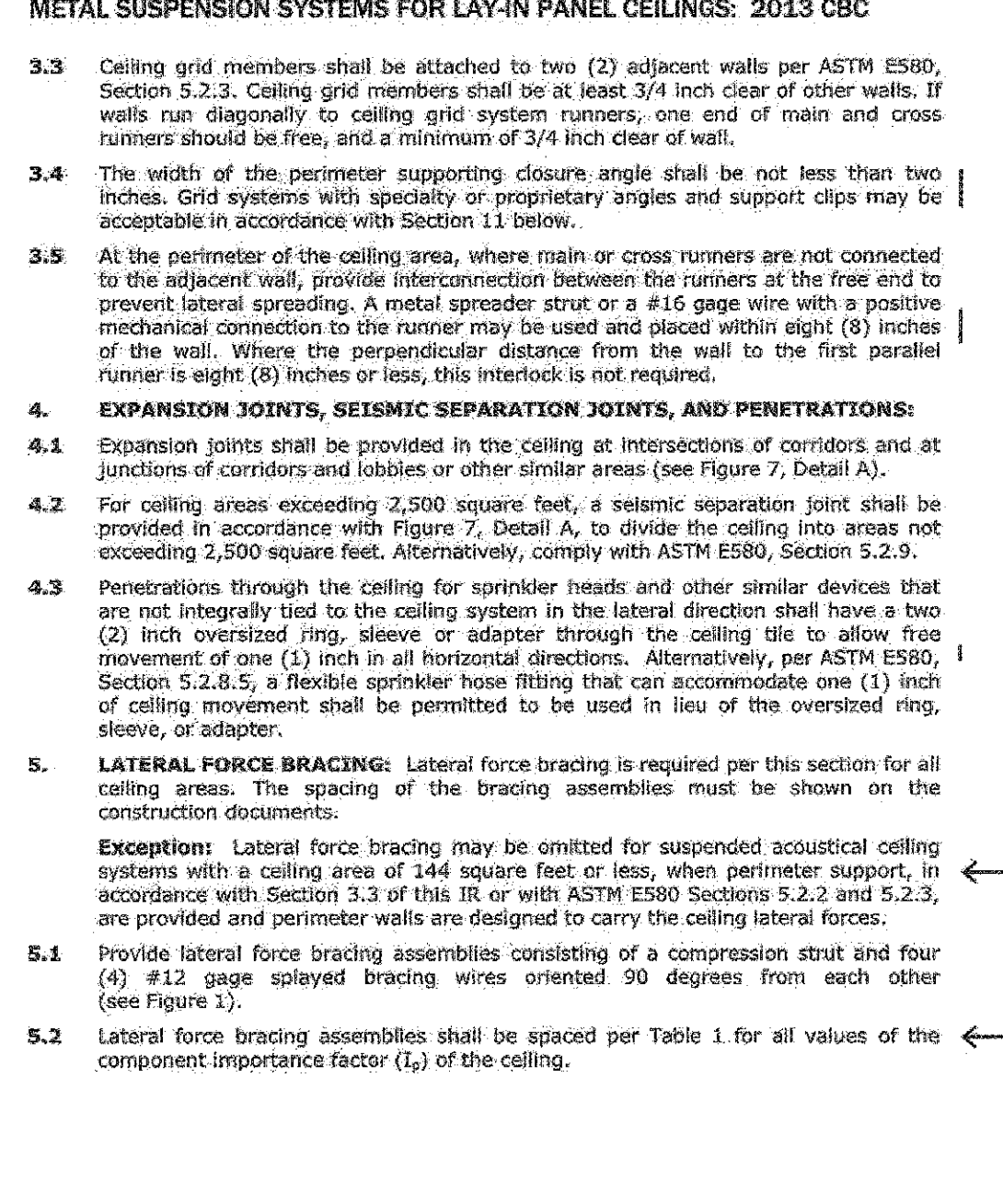
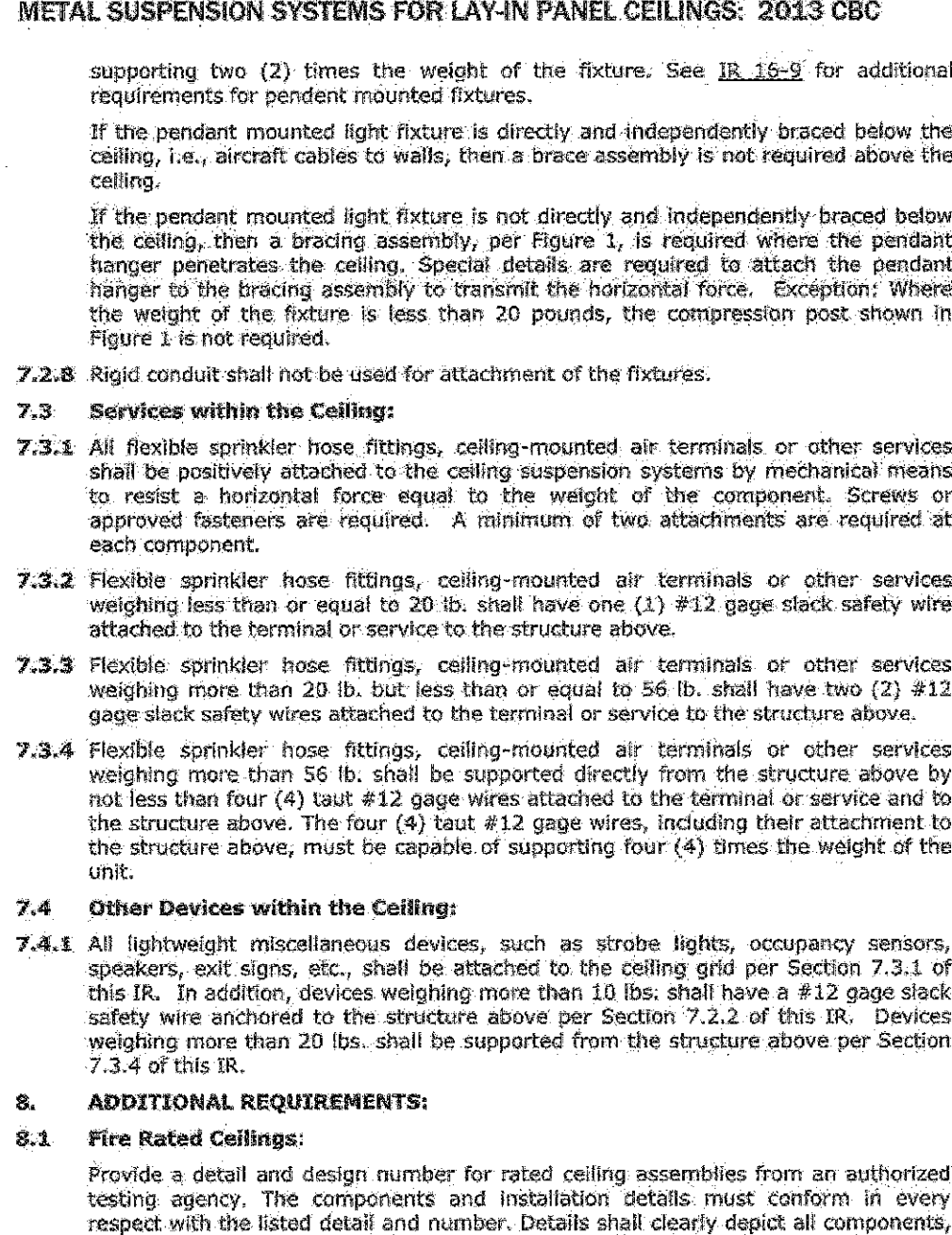
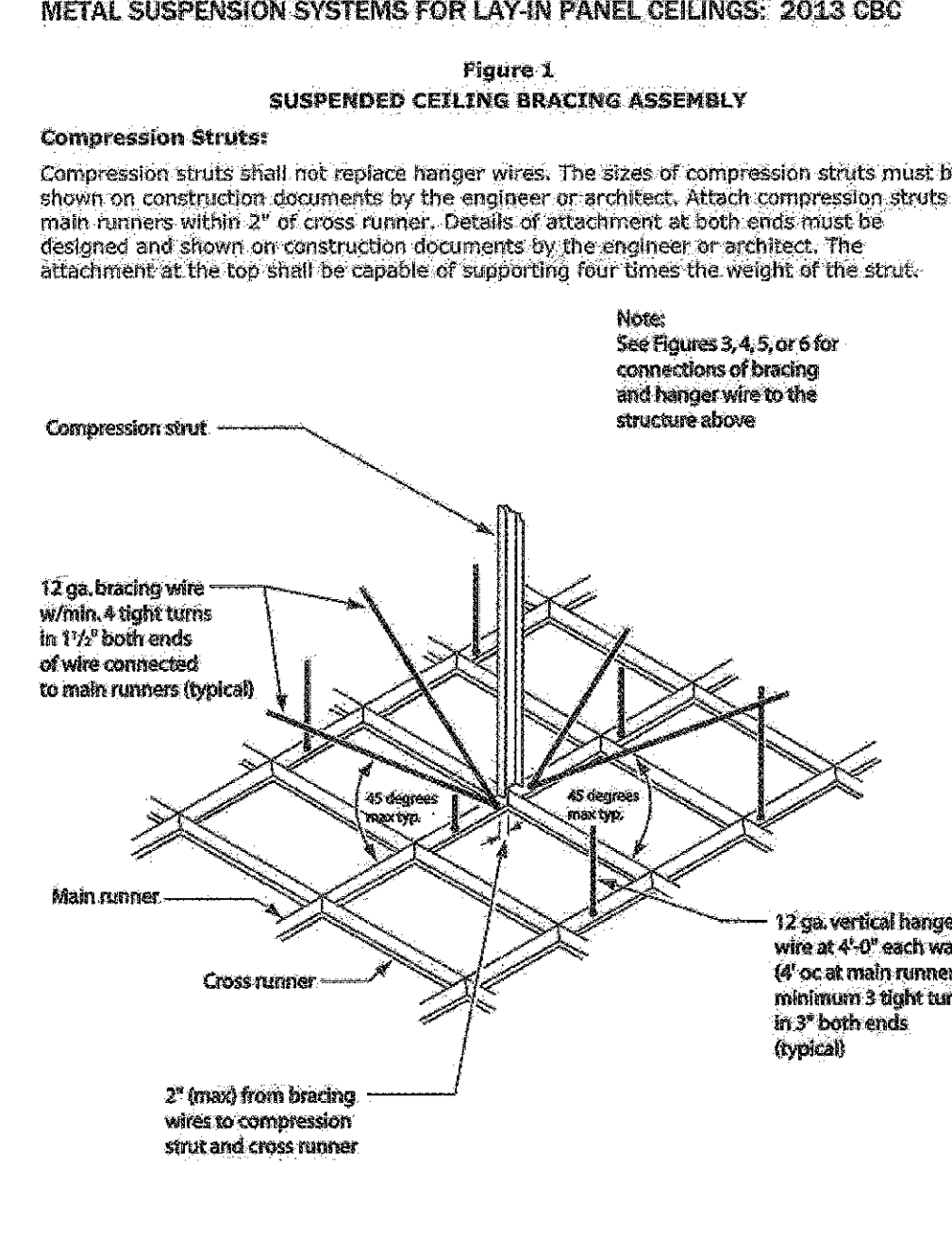
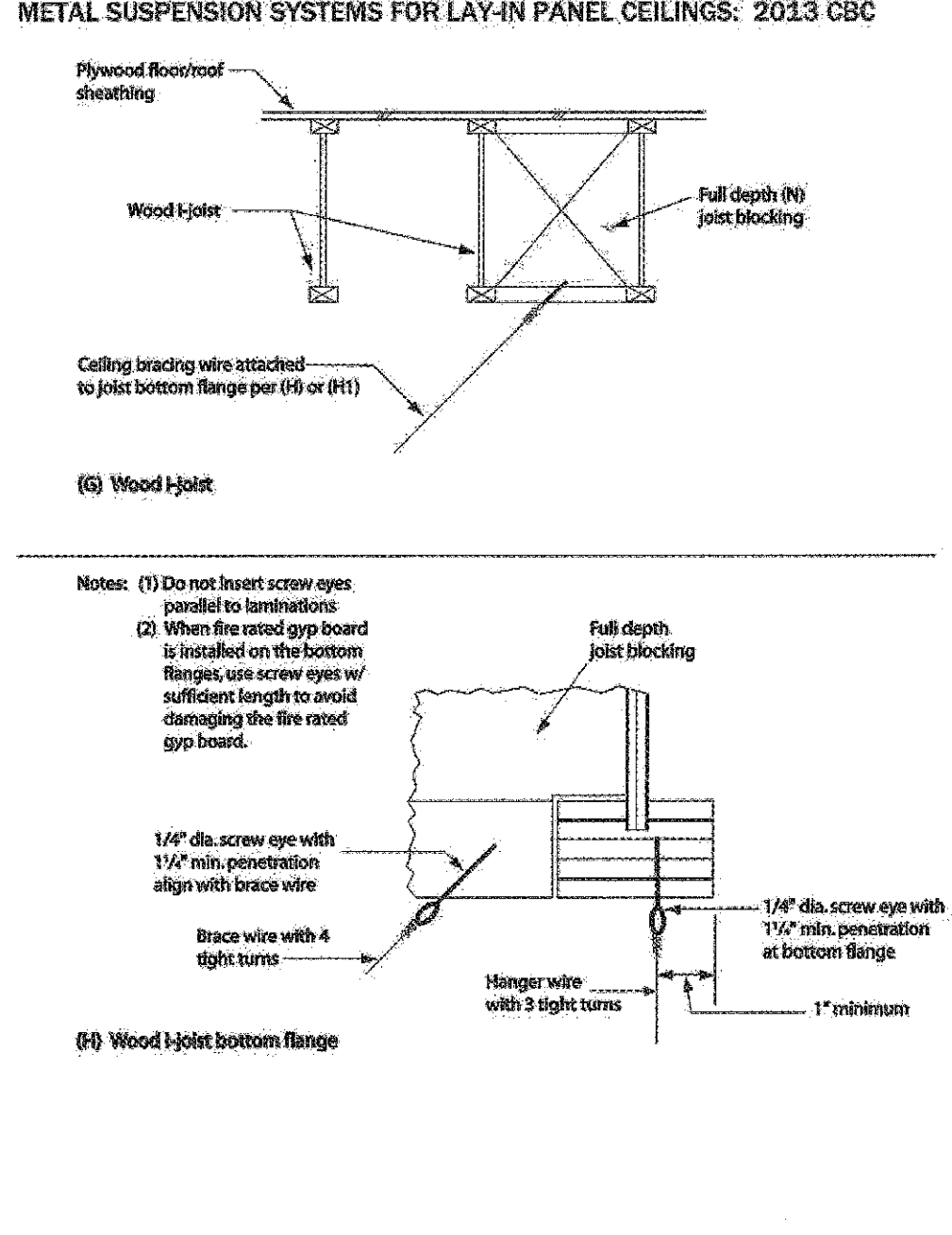
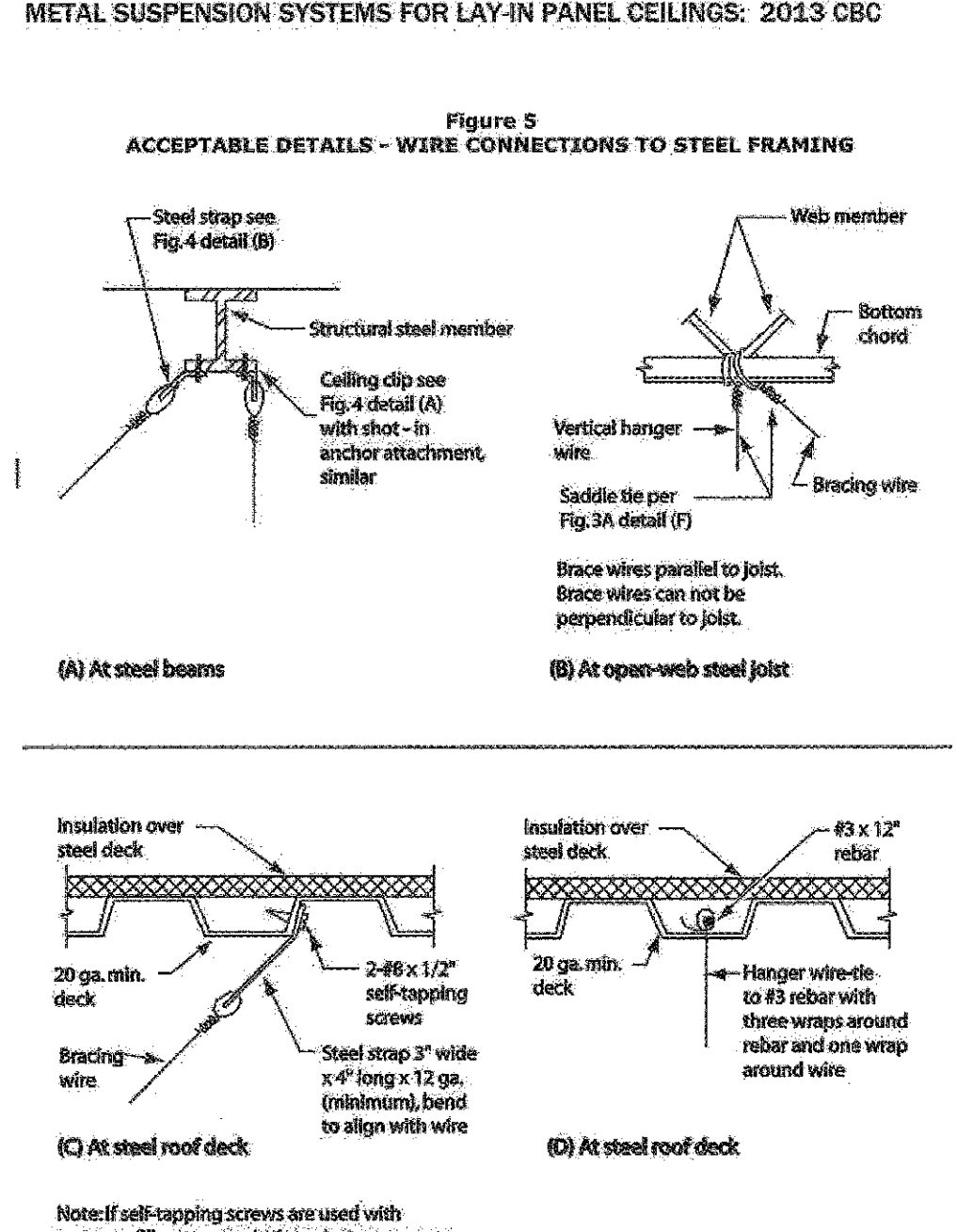

LITTLE
DIVERBRED ARCHITECTURAL CONSULTING
1300 Dove Street, Suite 100
Newport Beach, CA 92660
T: 949.698.1400 F: 949.698.1433
www.littleonline.com
© Little 2016

COMPTON
CCD
CAMPUS PUBLIC SAFETY BUILDING
1111 EAST ARTESIA BOULEVARD,
COMPTON CALIFORNIA 90221

IDENTIFICATION STAMP
DIV. OF THE STATE ARCHITECT
OFFICE OF REGULATION SERVICES
FILE NO: 19-C1
AC: 03-118783
DATE: DEC 1, 2017

PROJECT MANAGER
RITA S. CARTER
PROJECT MANAGER
SHOJI TAKESHIMA / DAVID PHAN
DRAWN BY
DAVID PHAN

LICENSED ARCHITECT
No. C25431
EXPI. 4-30-19
STATE OF CALIFORNIA

913-4675-00
12/01/16 A9.1.3

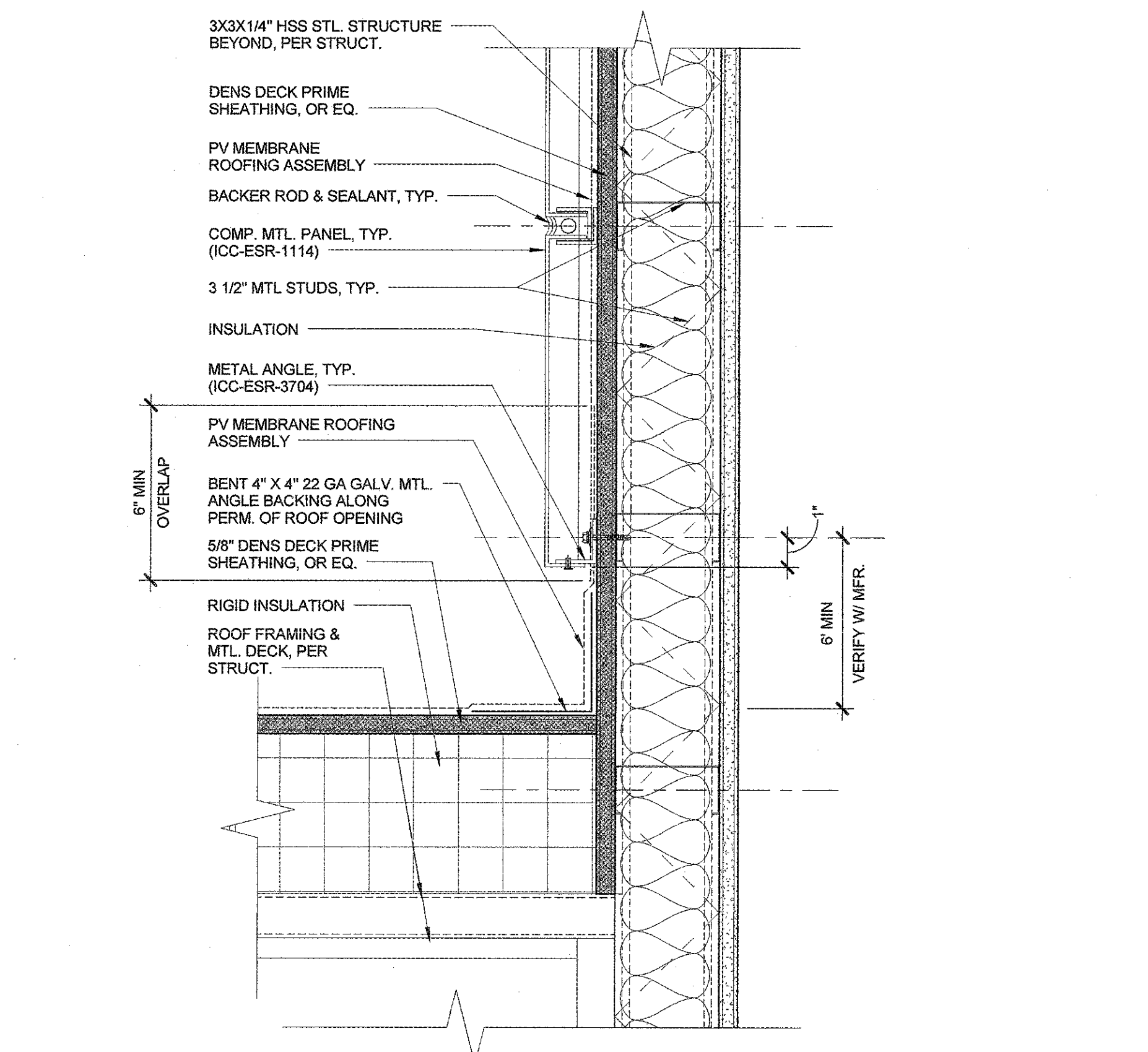

6 TYP. CLERESTORY @ ROOF OPENING
A9.1.4 3" = 1'-0"

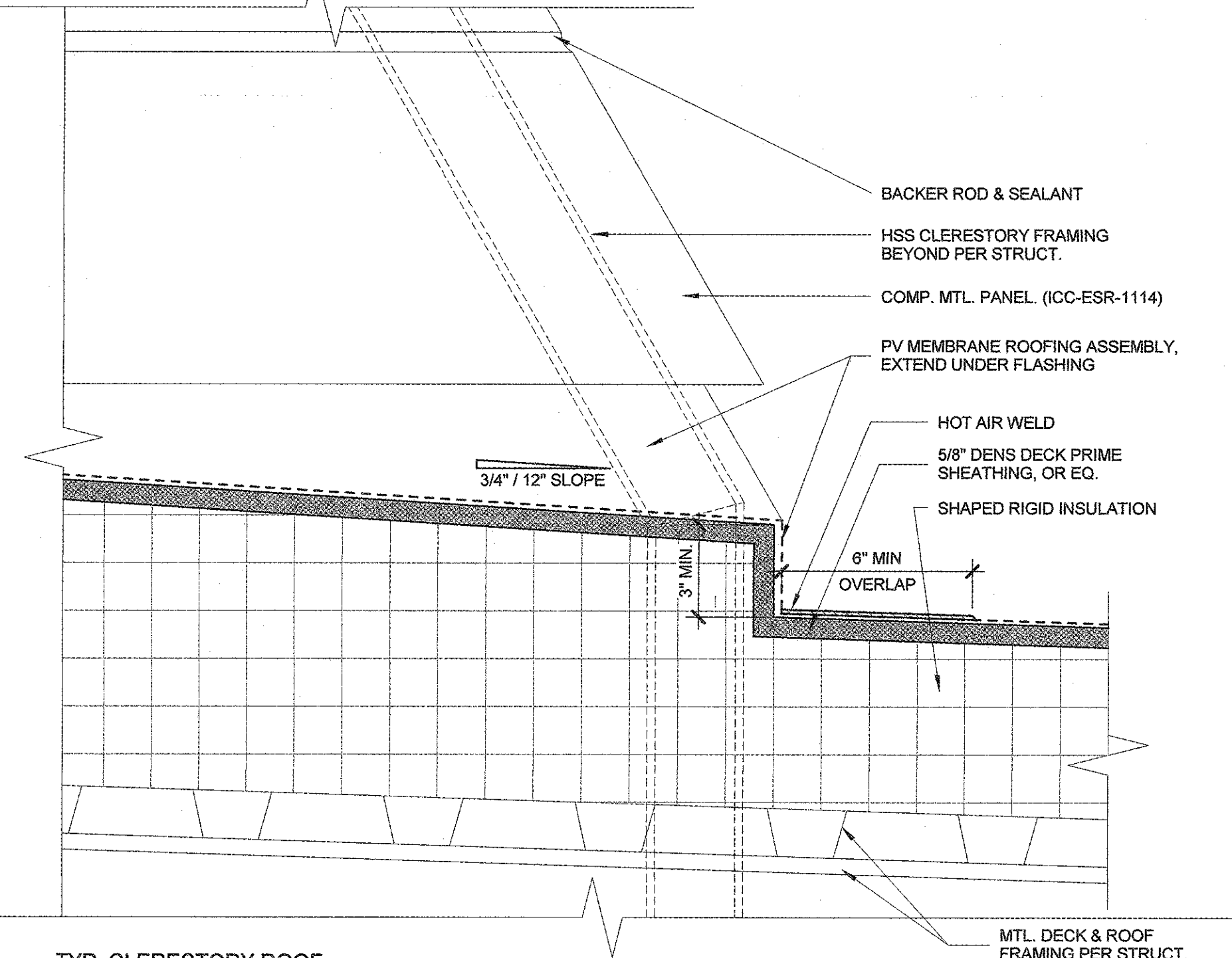

7 TYP. CLERESTORY WINDOW @ HEAD, JAMB SIM.
A9.1.4 3" = 1'-0"

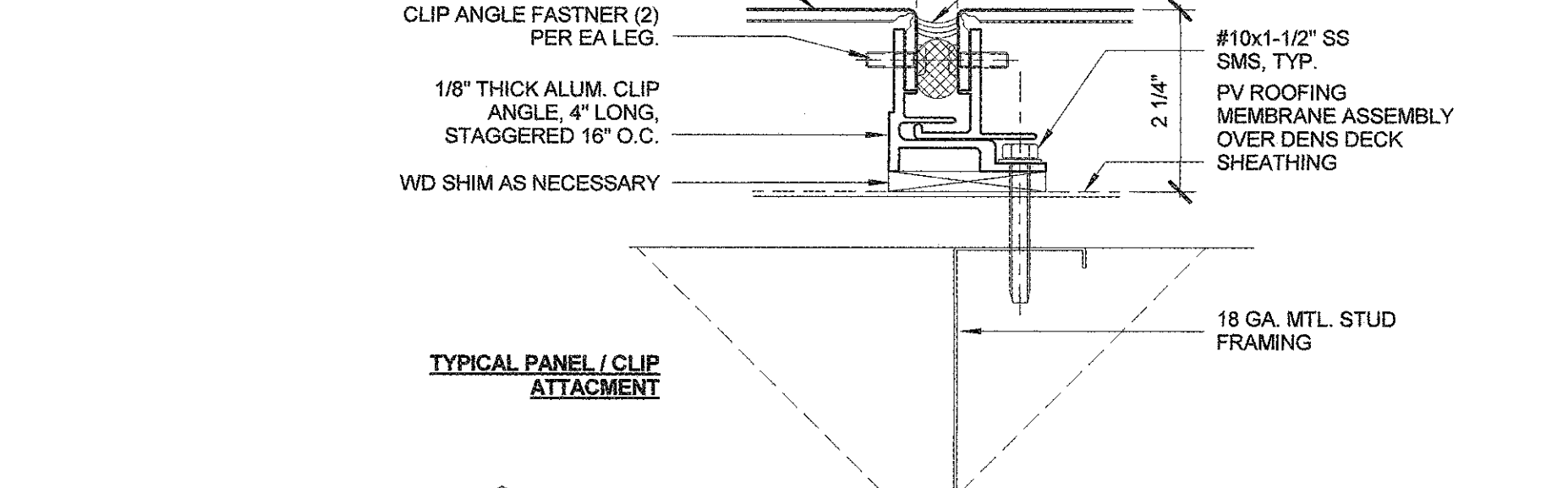

8 TYP. CLERESTORY WINDOW ROOF TRANSITION
A9.1.4 3" = 1'-0"

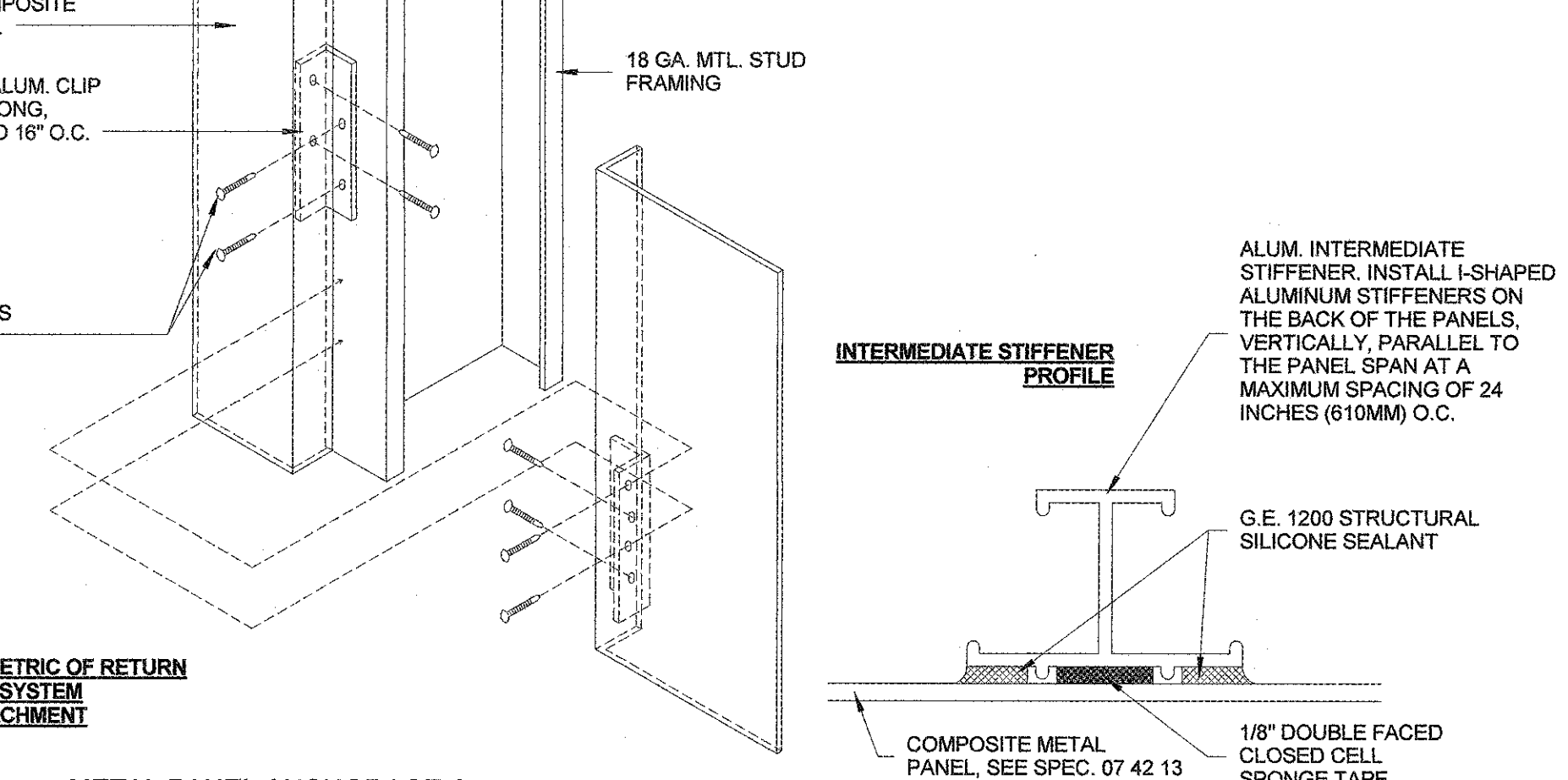

9 TYP. CLERESTORY WINDOW SILL
A9.1.4 3" = 1'-0"

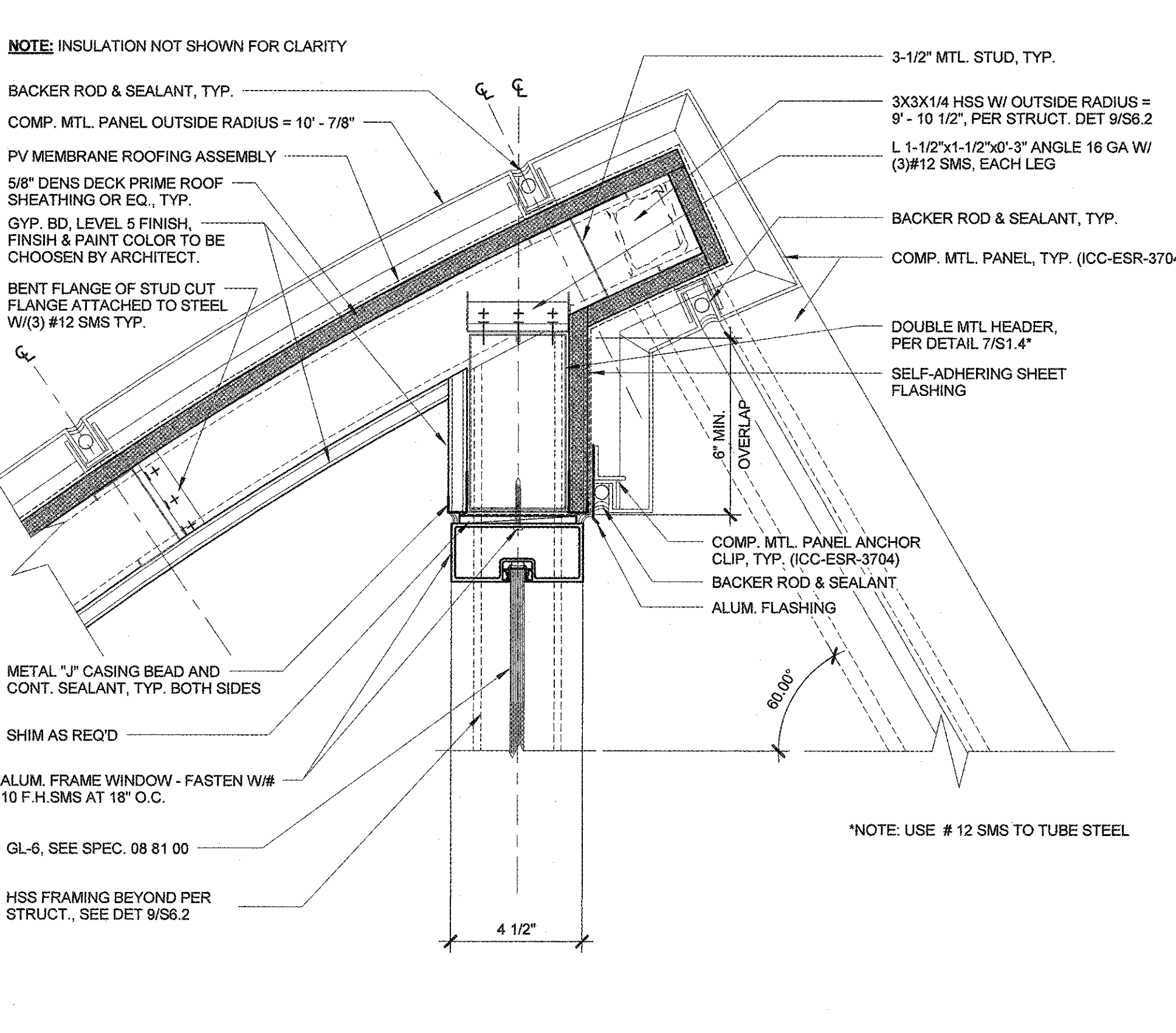

10 TYP. CLERESTORY WINDOW @ BOTTOM
A9.1.4 3" = 1'-0"

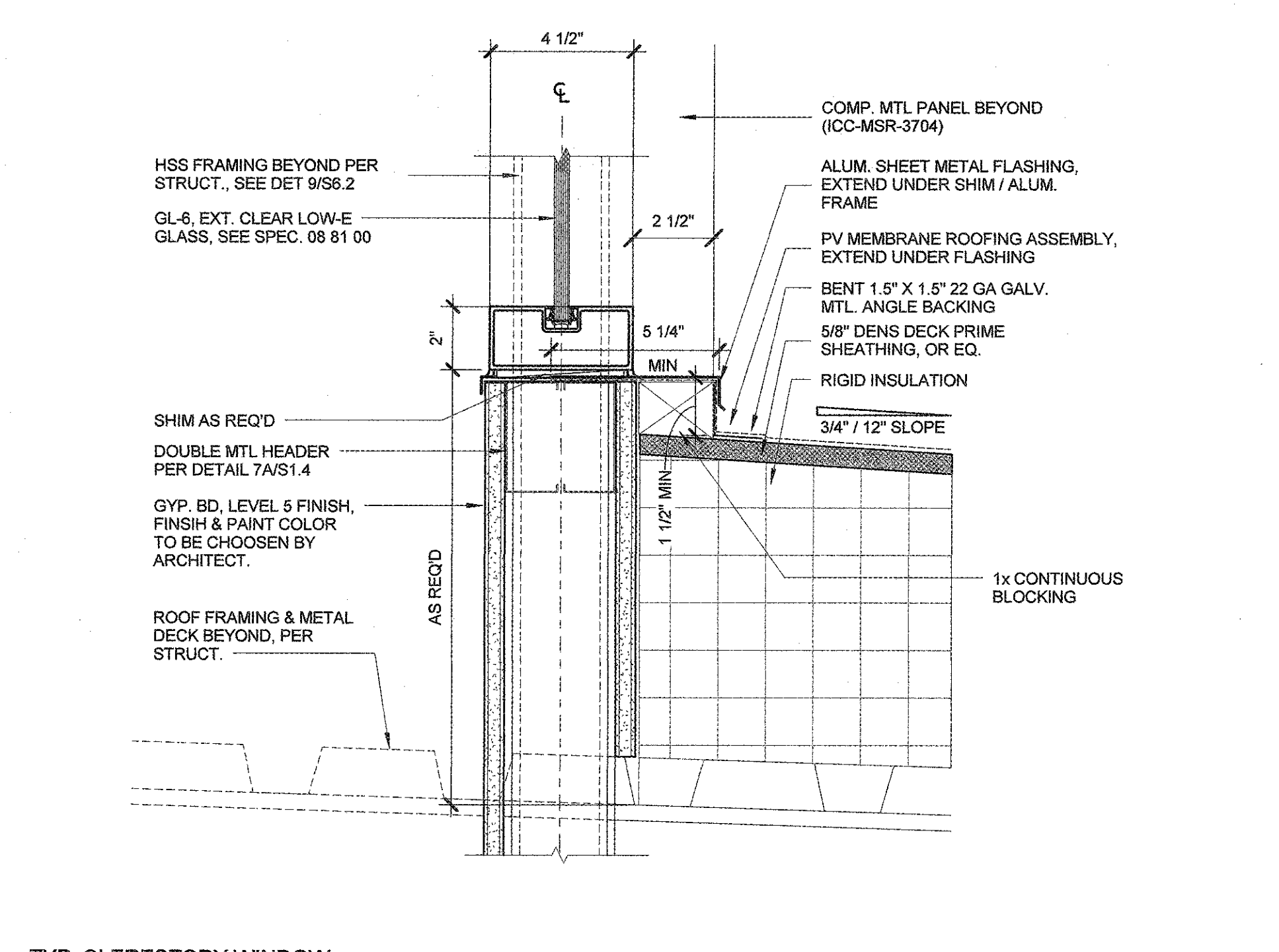

11 TYP. CLERESTORY WINDOW @ BOTTOM OF CLERESTORY
A9.1.4 3" = 1'-0"

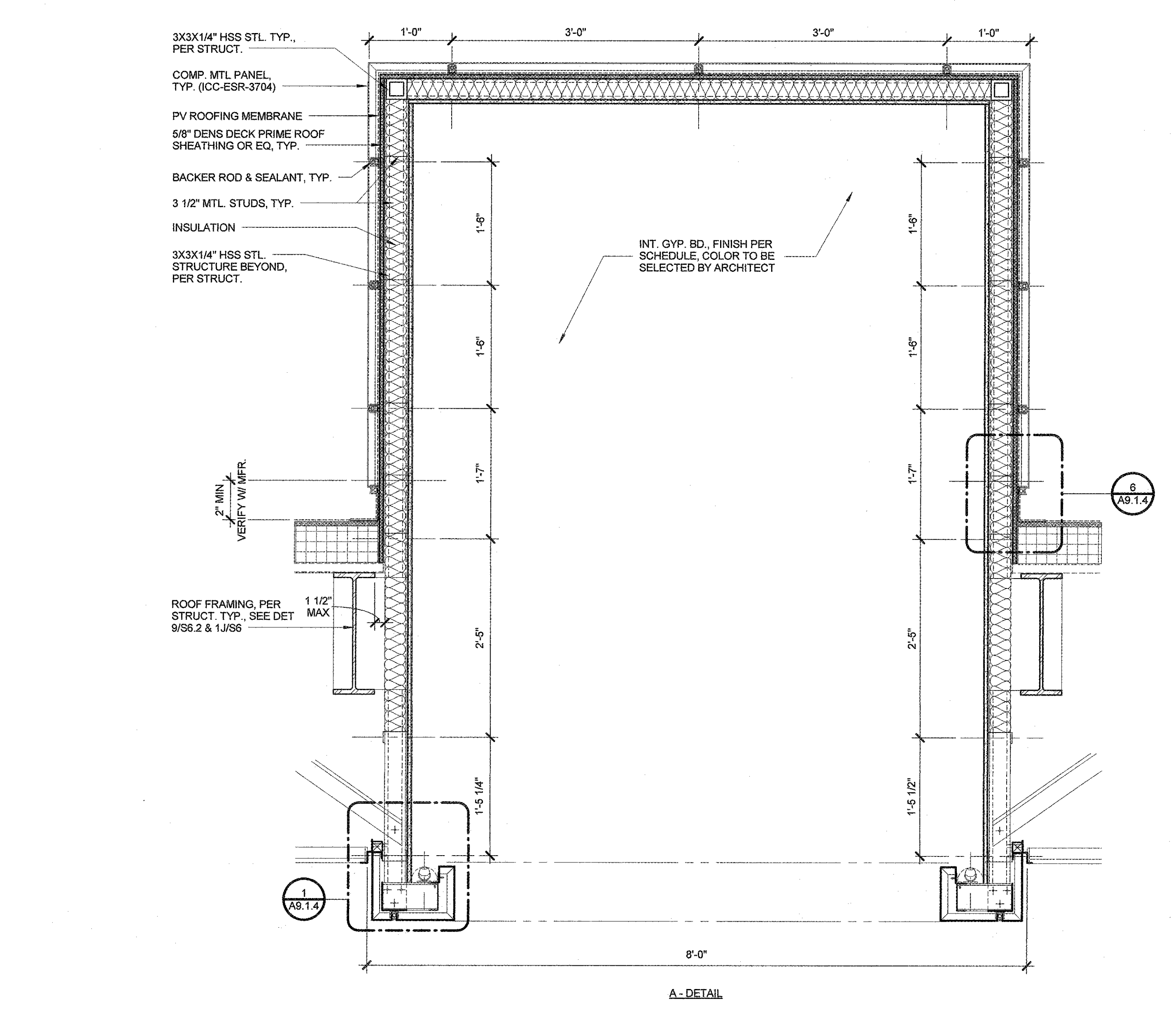

12 TYP. CLERESTORY - SECTION A
A9.1.4 1" = 1'-0"

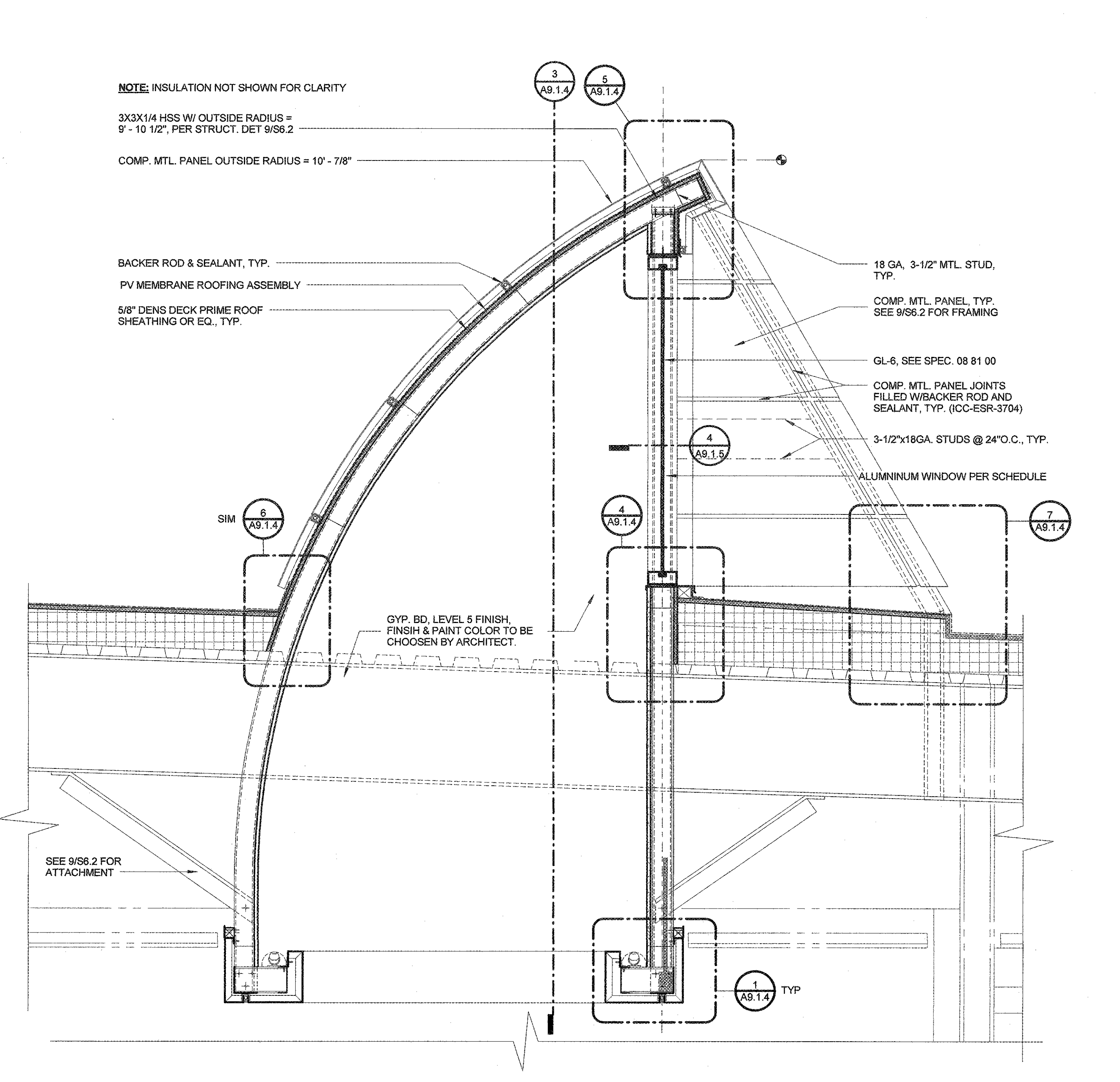

13 TYP. CLERESTORY - SECTION B
A9.1.4 1" = 1'-0"

14 METAL PANEL ANCHORAGE & STIFFENER
A9.1.4 8" = 1'-0"

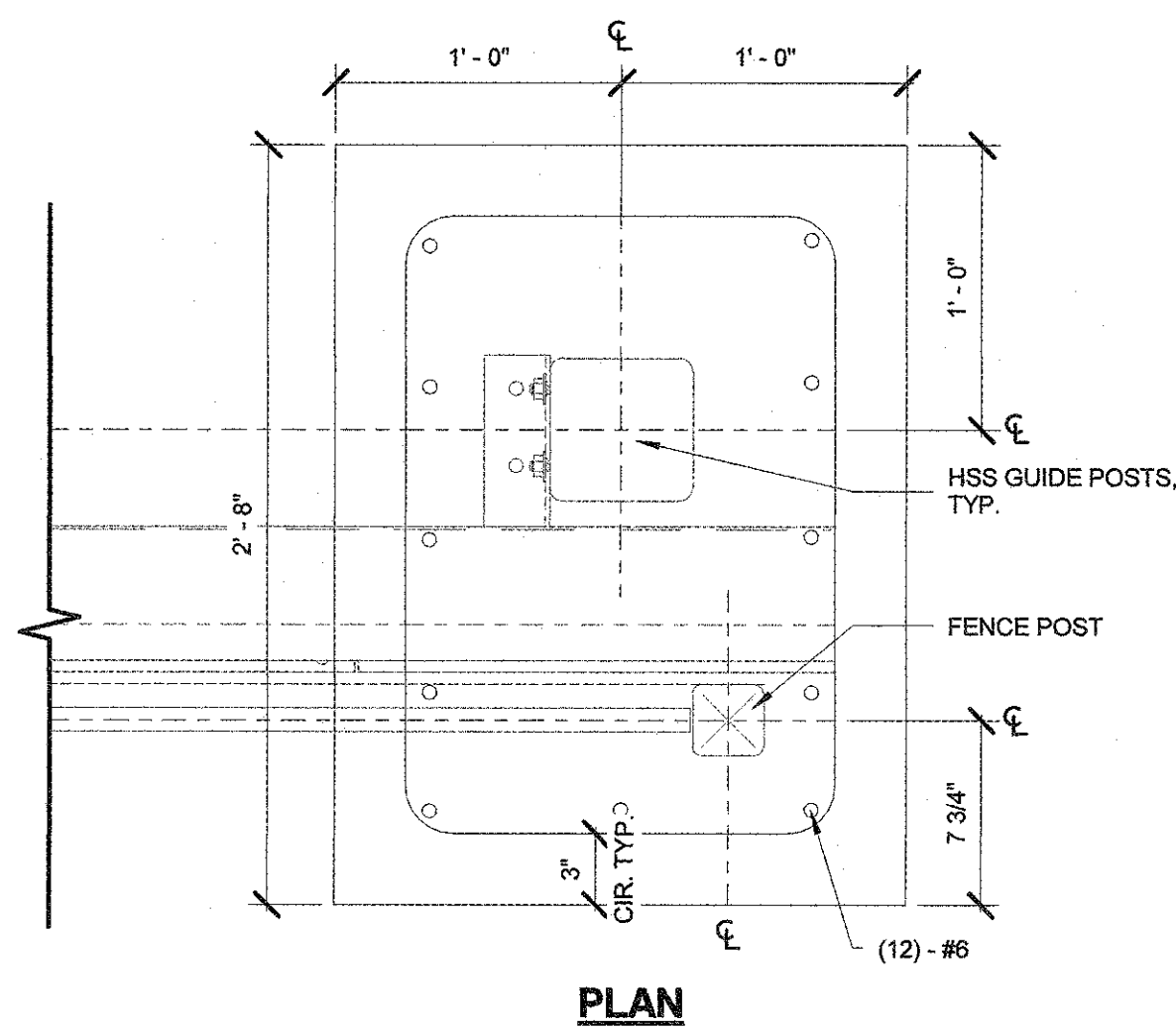

PLAN

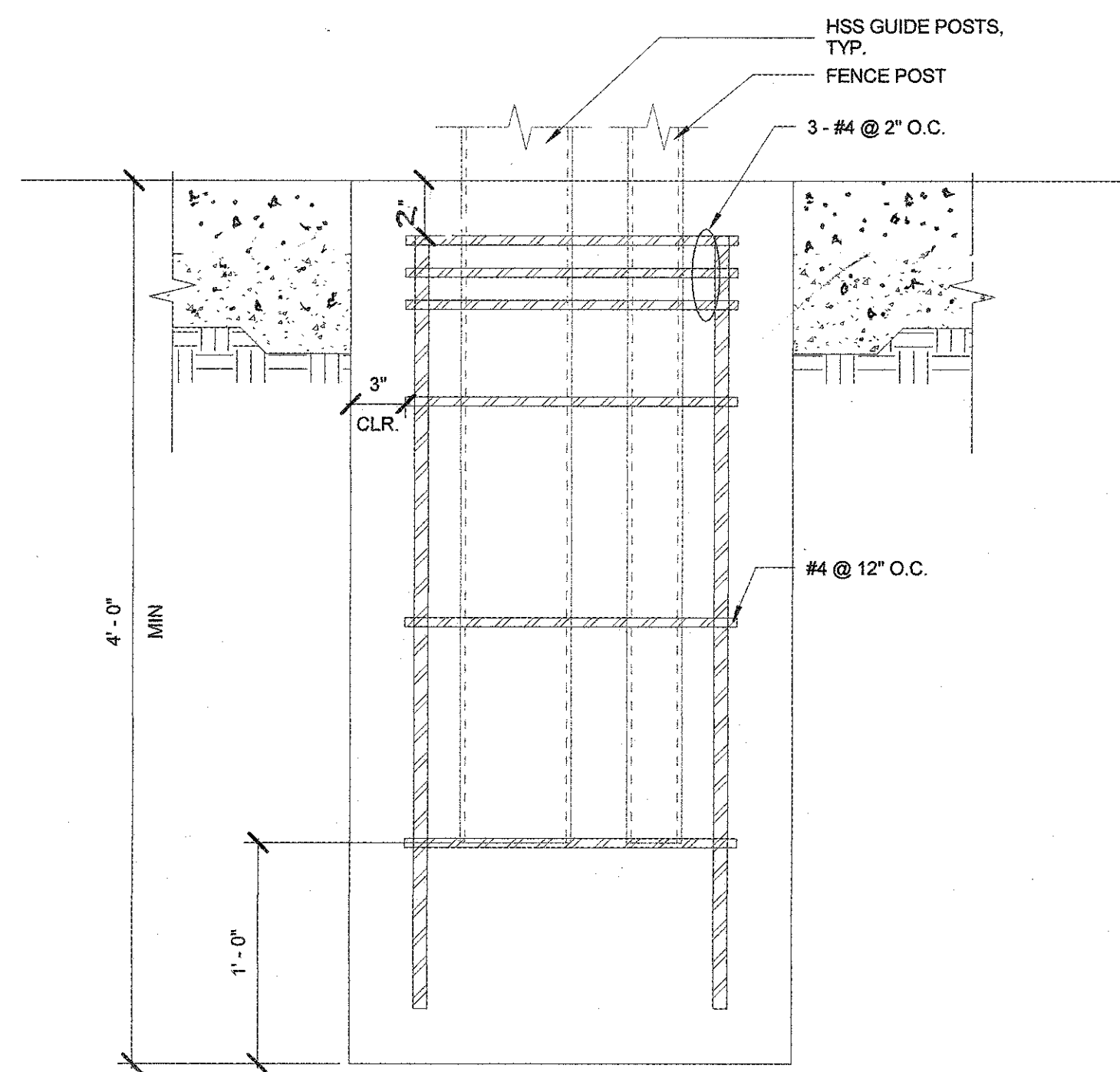

SECTION

6 ROLLING GATE & FENCE POST COMBINED FOOTING
A9.1.5 1 1/2" = 1'-0"

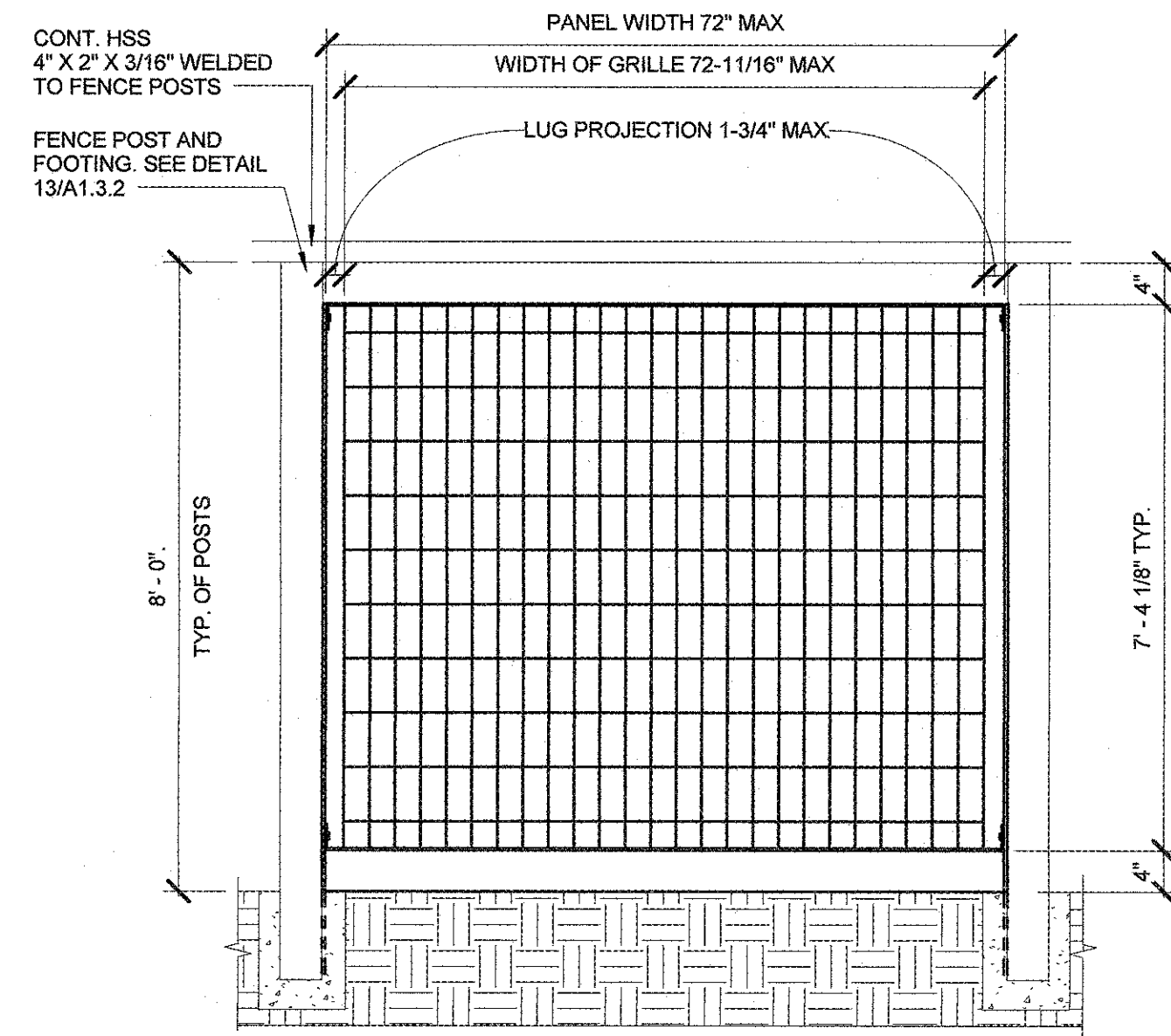

A TYPICAL ELEVATION FENCE ELEVATION

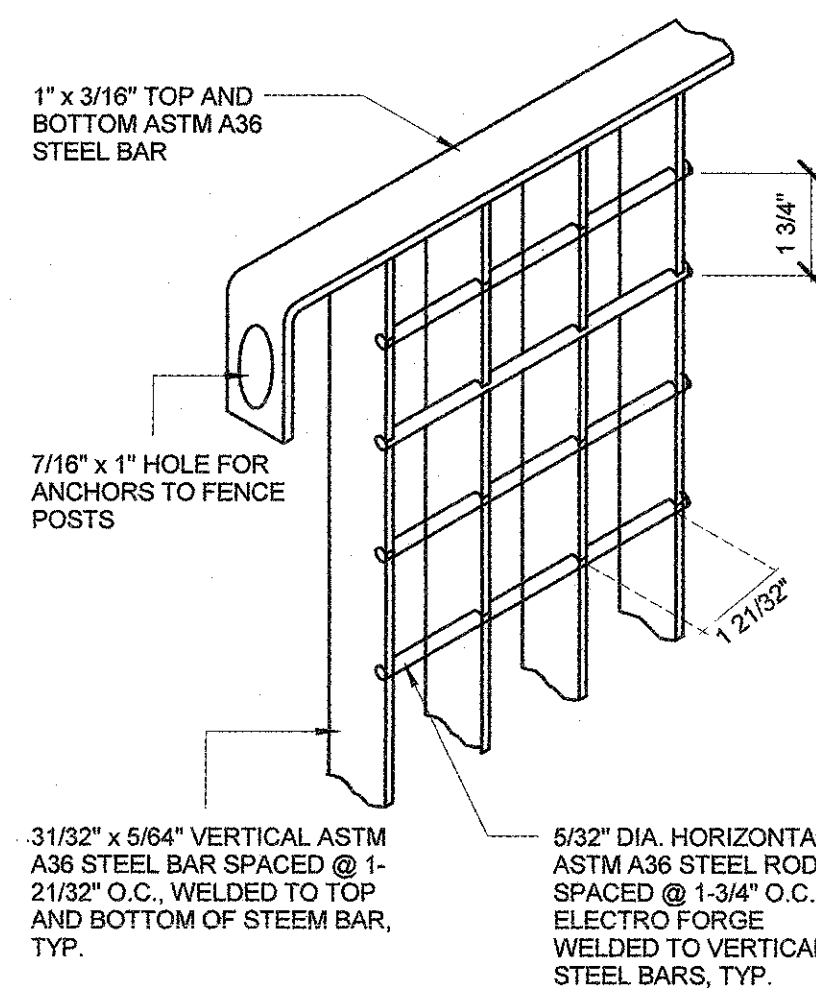

B FENCE & GATE INFILL TYPE "A"

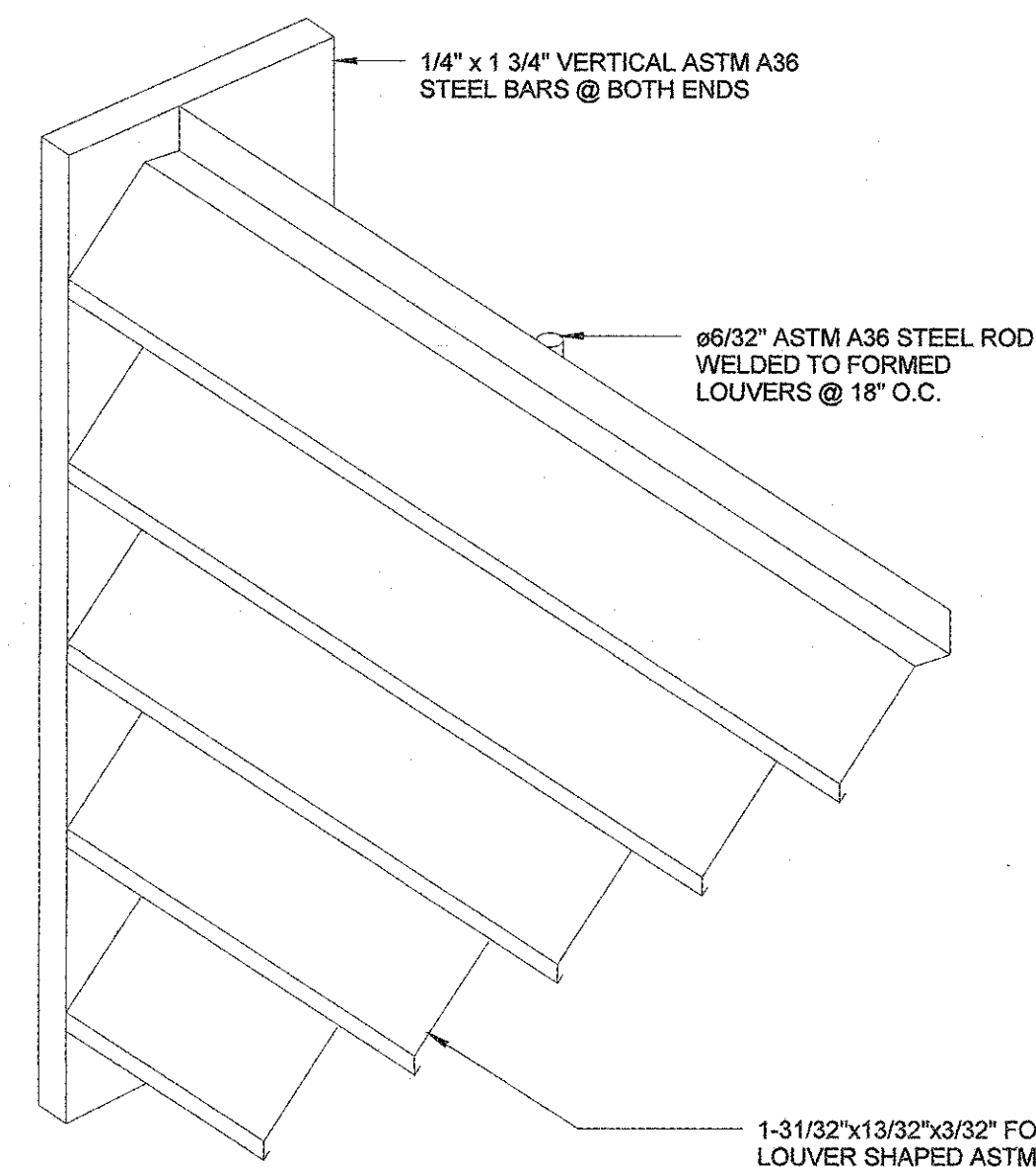

C ISOMETRIC

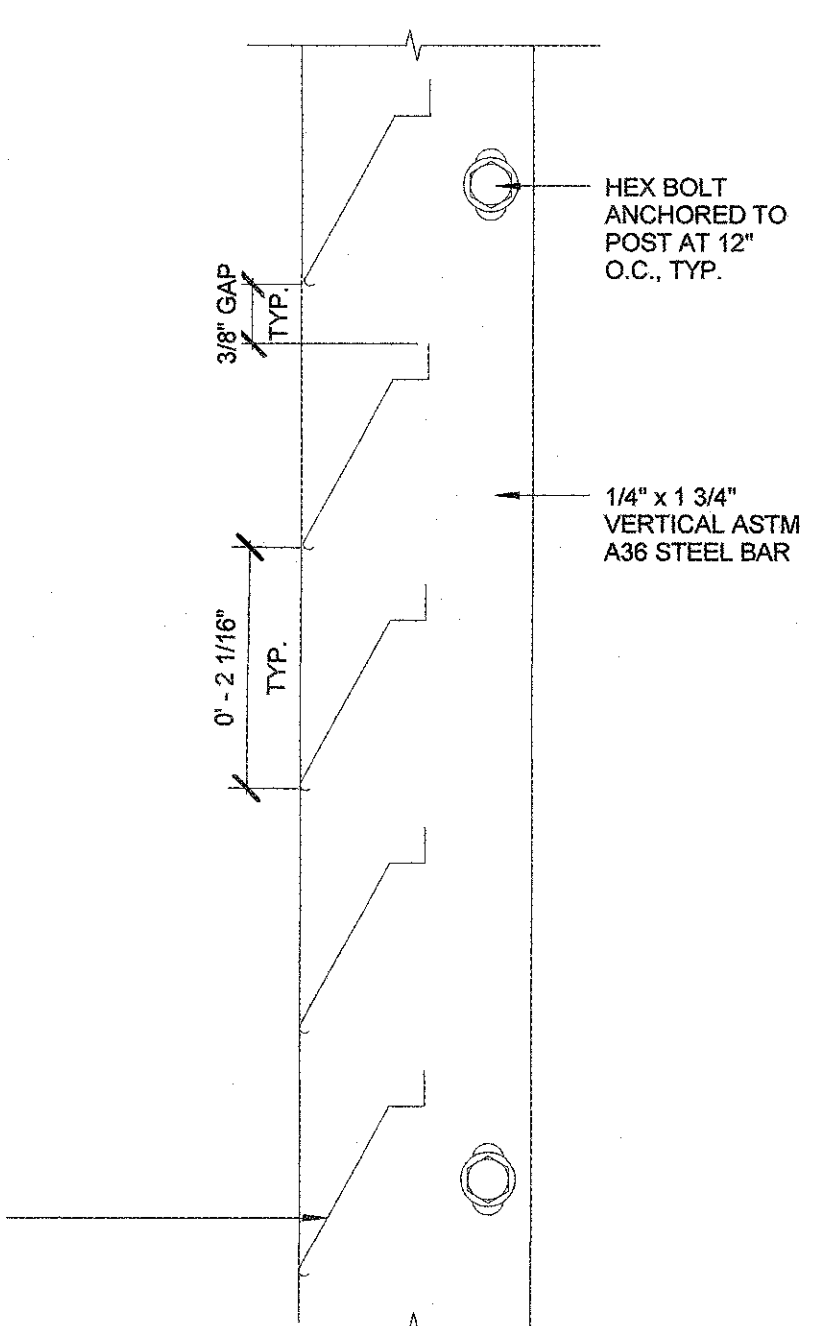

D INFILL SECTION

C FENCE & GATE

D FENCE & GATE INFILL TYPE "B"

5 FENCE & GATE DETAILS
A9.1.5 3/4" = 1'-0"

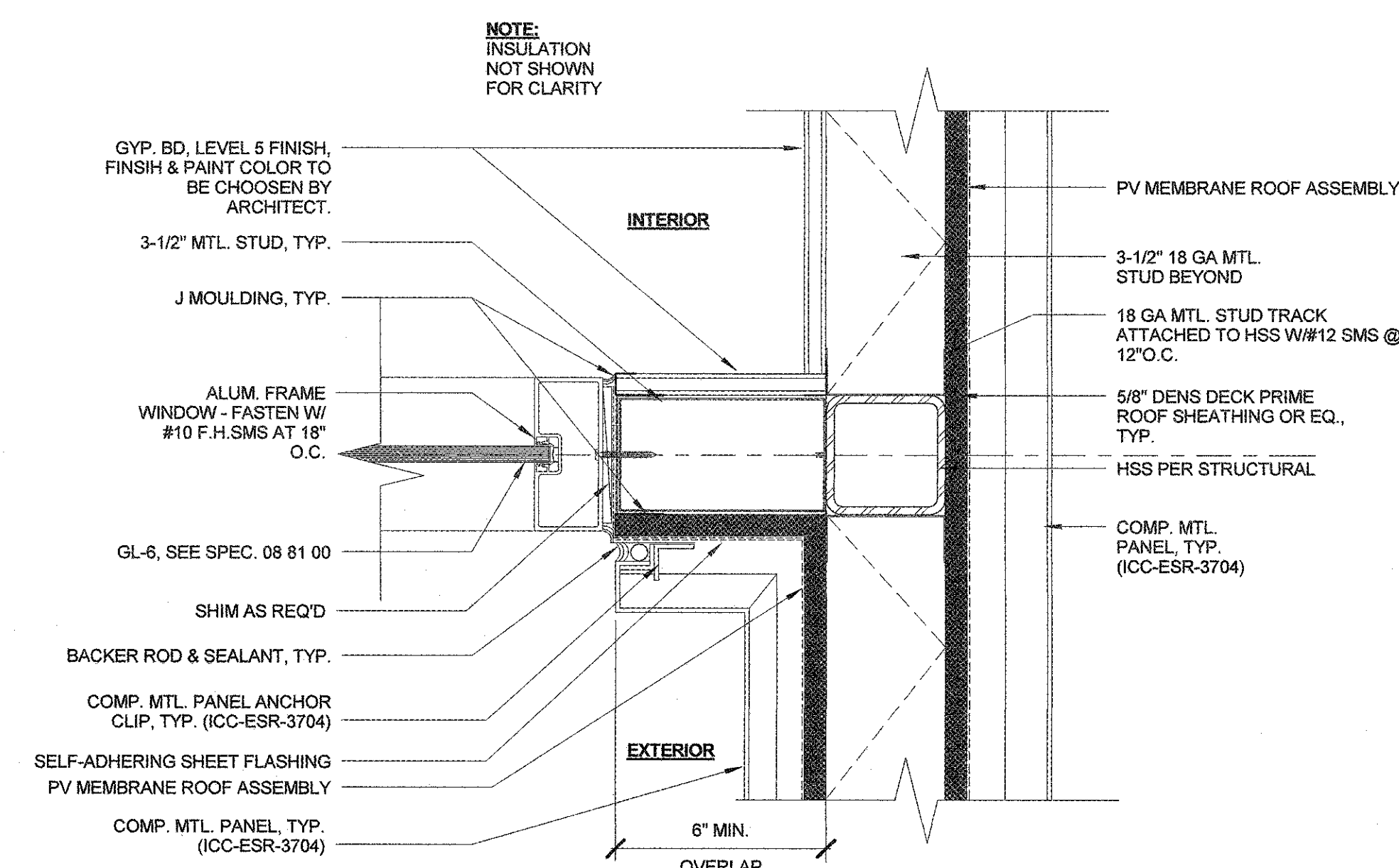

4 TYP. CLERESTORY WINDOW @ JAMB
A9.1.5 3" = 1'-0"

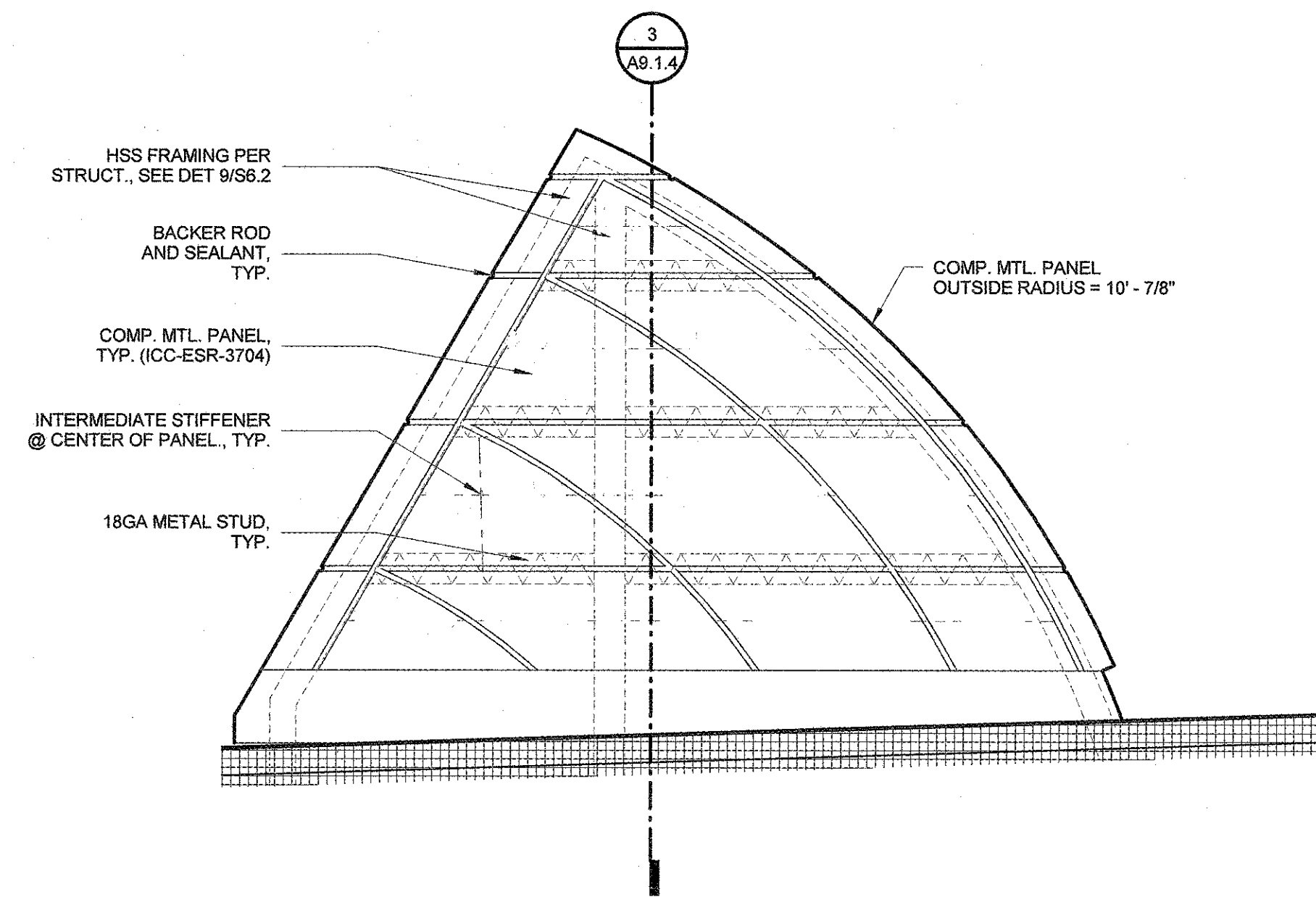

3 MONITOR SIDE PANELING
A9.1.5 3/4" = 1'-0"

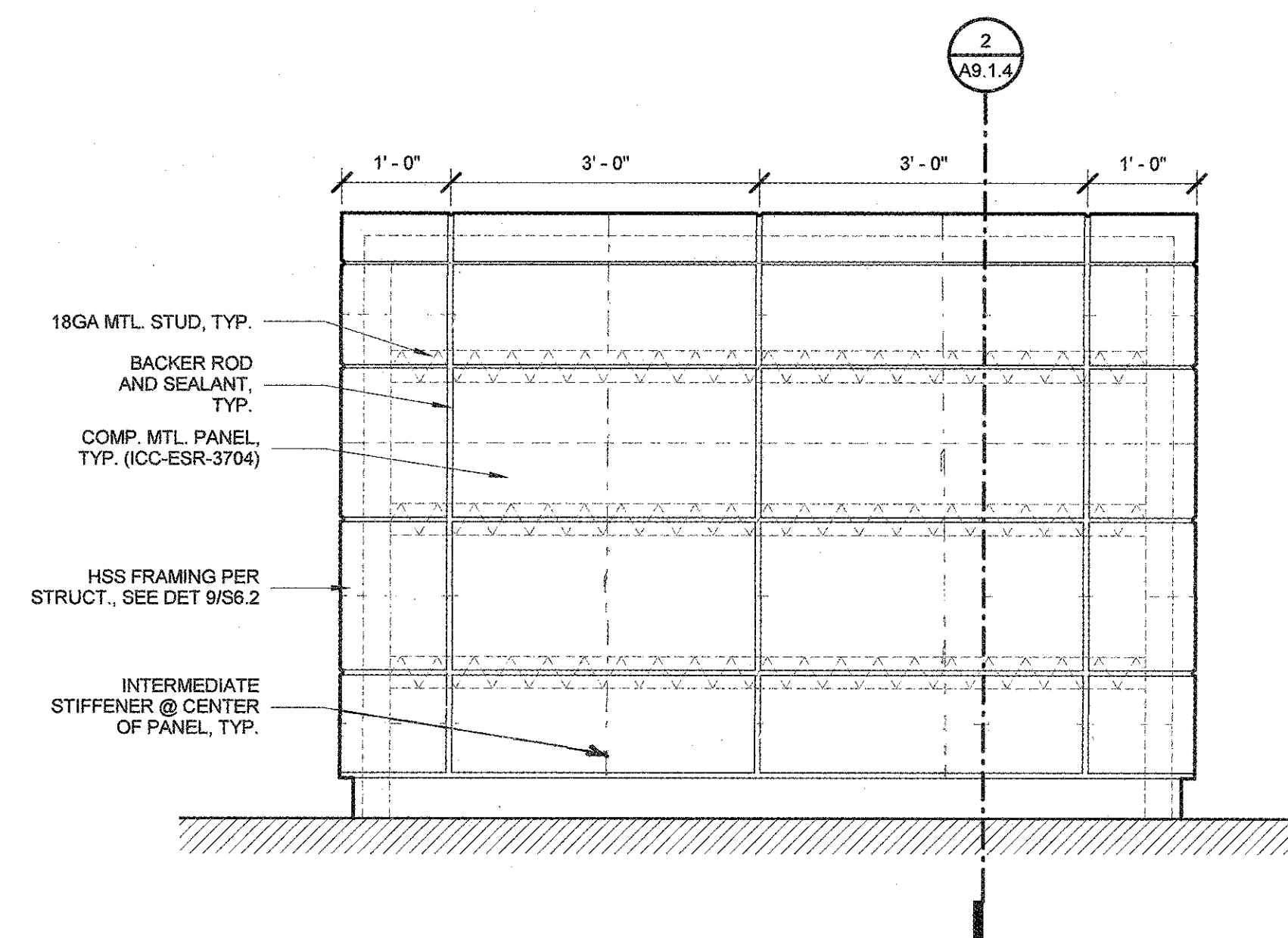

2 MONITOR REAR PANELING
A9.1.5 3/4" = 1'-0"

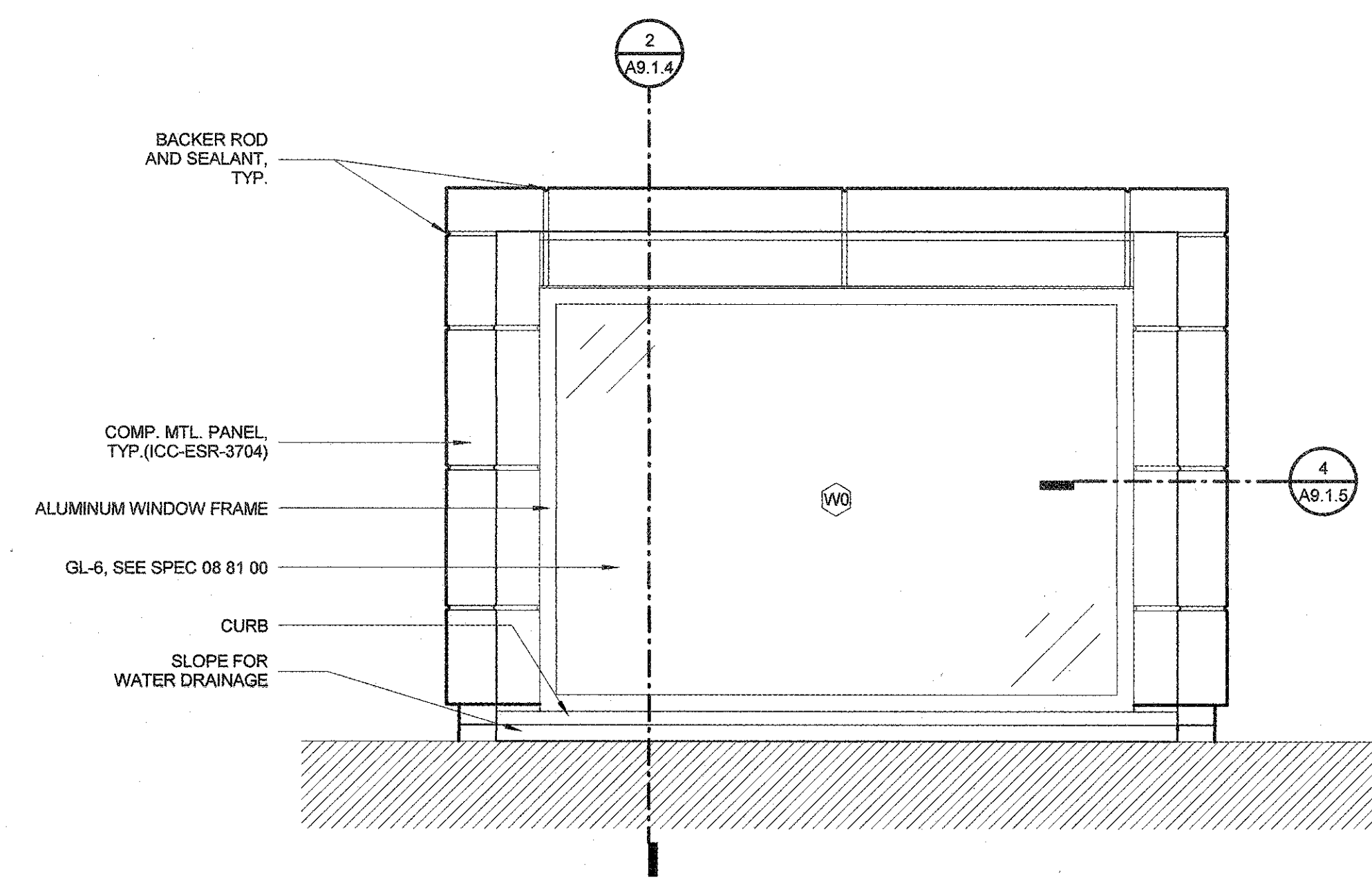

1 MONITOR OPENING
A9.1.5 3/4" = 1'-0"

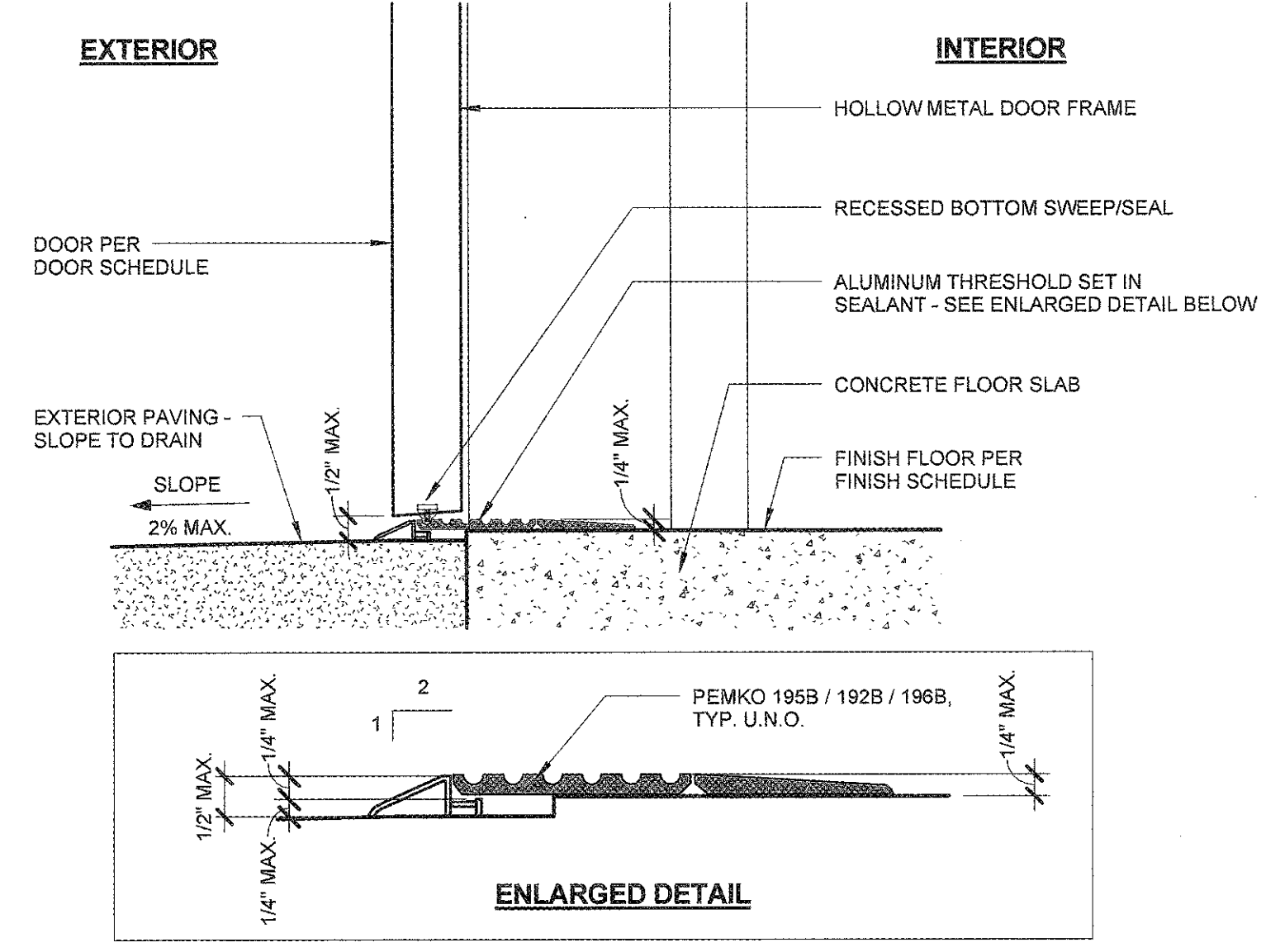

A TYP. THRESHOLD @ EXT DOOR

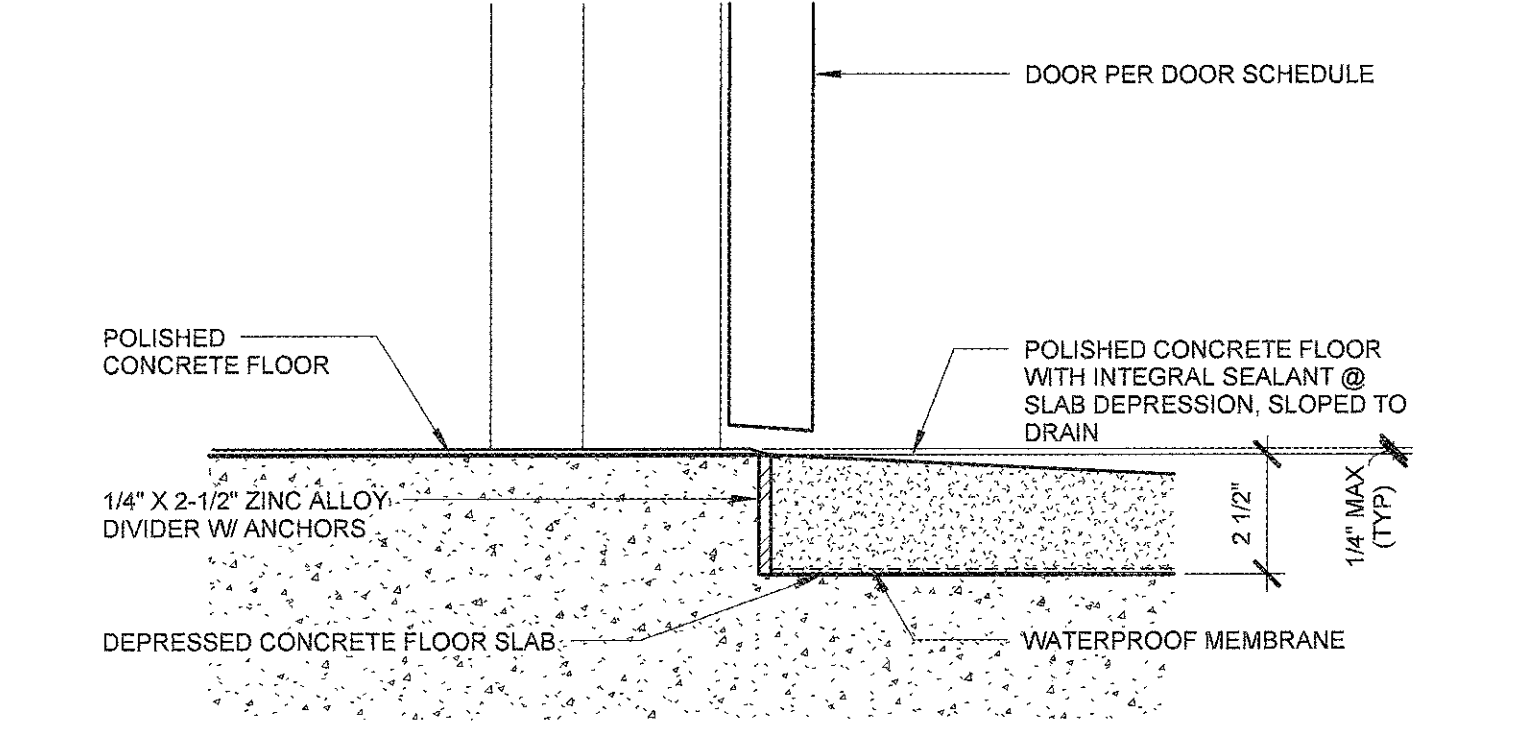

B POLISHED CONCRETE to CERAMIC TILE

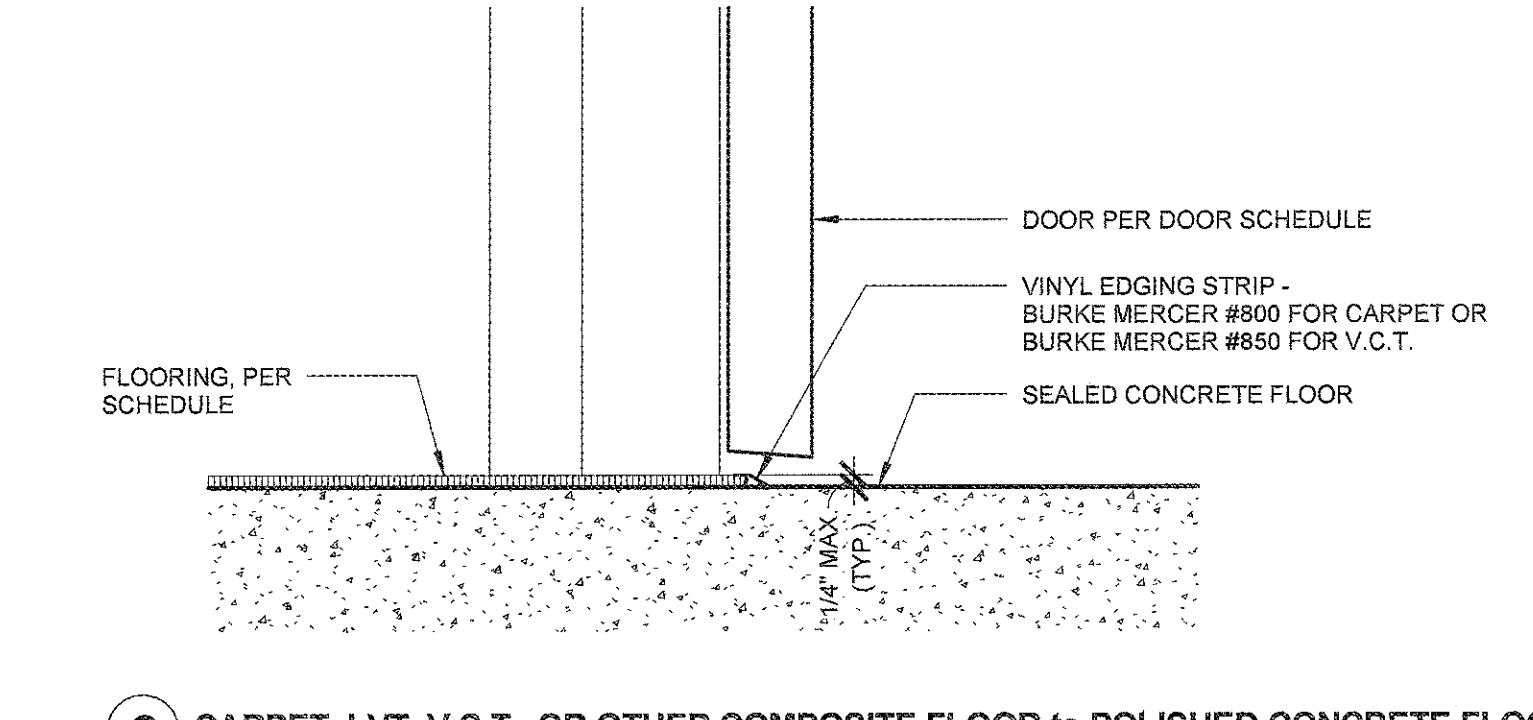

C CARPET, LVT, V.C.T., OR OTHER COMPOSITE FLOOR to POLISHED CONCRETE FLOOR

NOTE:
1. AT ALL ACCESSIBLE THRESHOLDS, PROVIDE A MAXIMUM OF 1/4-INCH IN HEIGHT AT TRANSITIONS AND BEVELED PER C.C.C. SECTION 1115B.4.4.2 AND FIGURE 11B-32.
2. VINYL EDGING STRIP COLOR TO BE SELECTED BY ARCHITECT FROM FULL COLOR LINE.

9 TYP. DOOR THRESHOLDS
A9.3.1 3" = 1'-0"

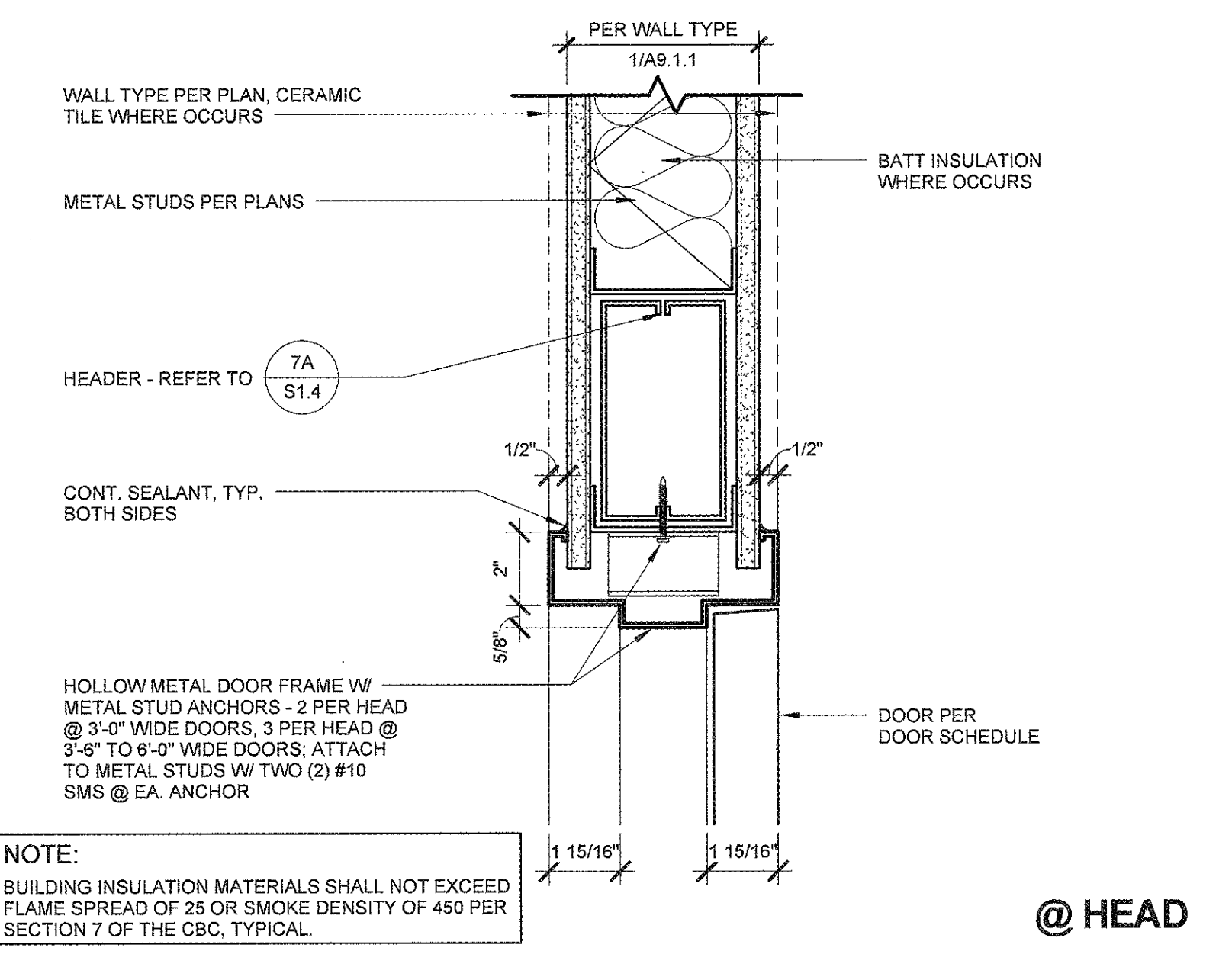

5 TYP. INTERIOR HOLLOW METAL FRAME DOOR
A9.3.1 3" = 1'-0"

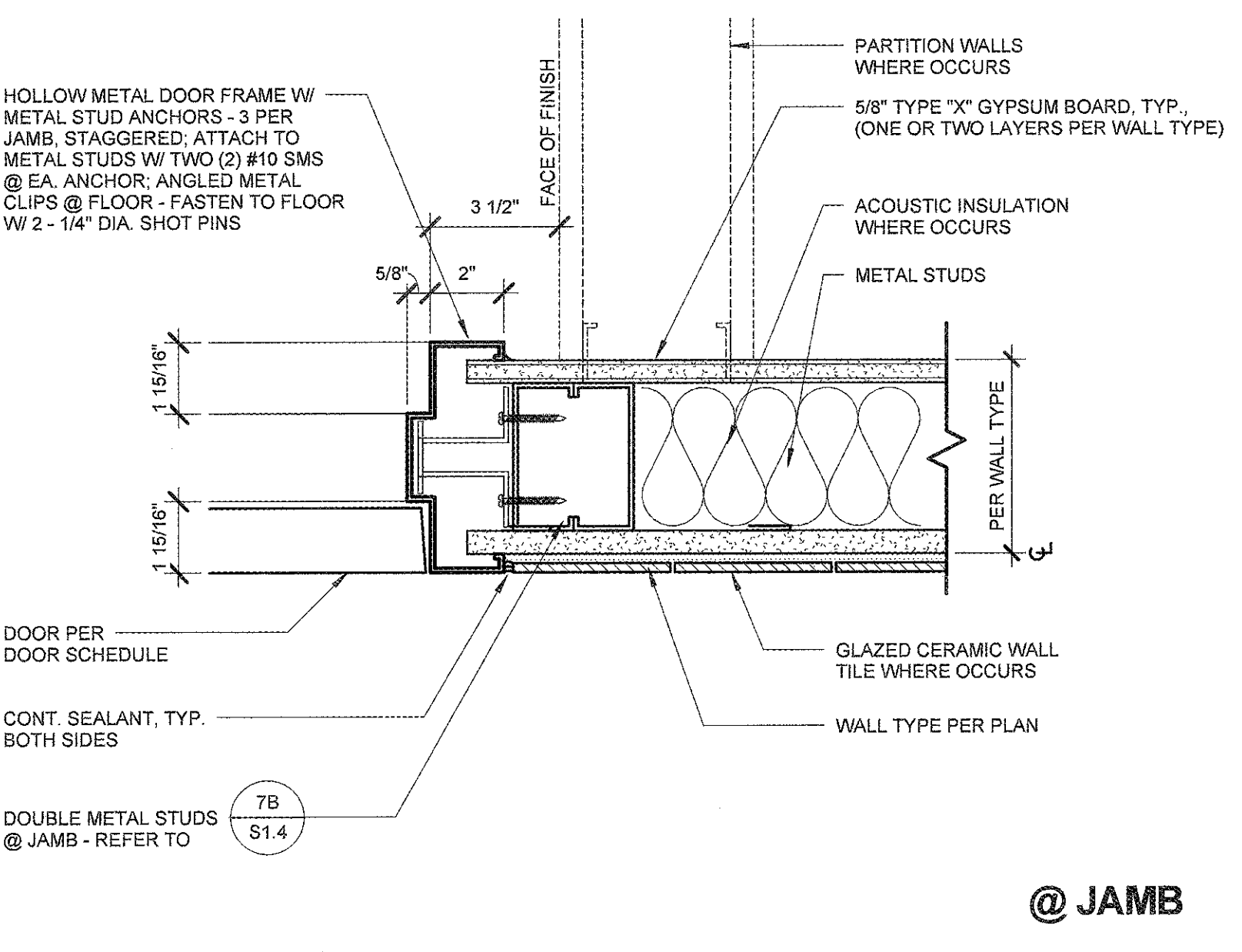

6 TYP. INT. H.M. FRAME DOOR AT CERAMIC TILE WALL
A9.3.1 3" = 1'-0"

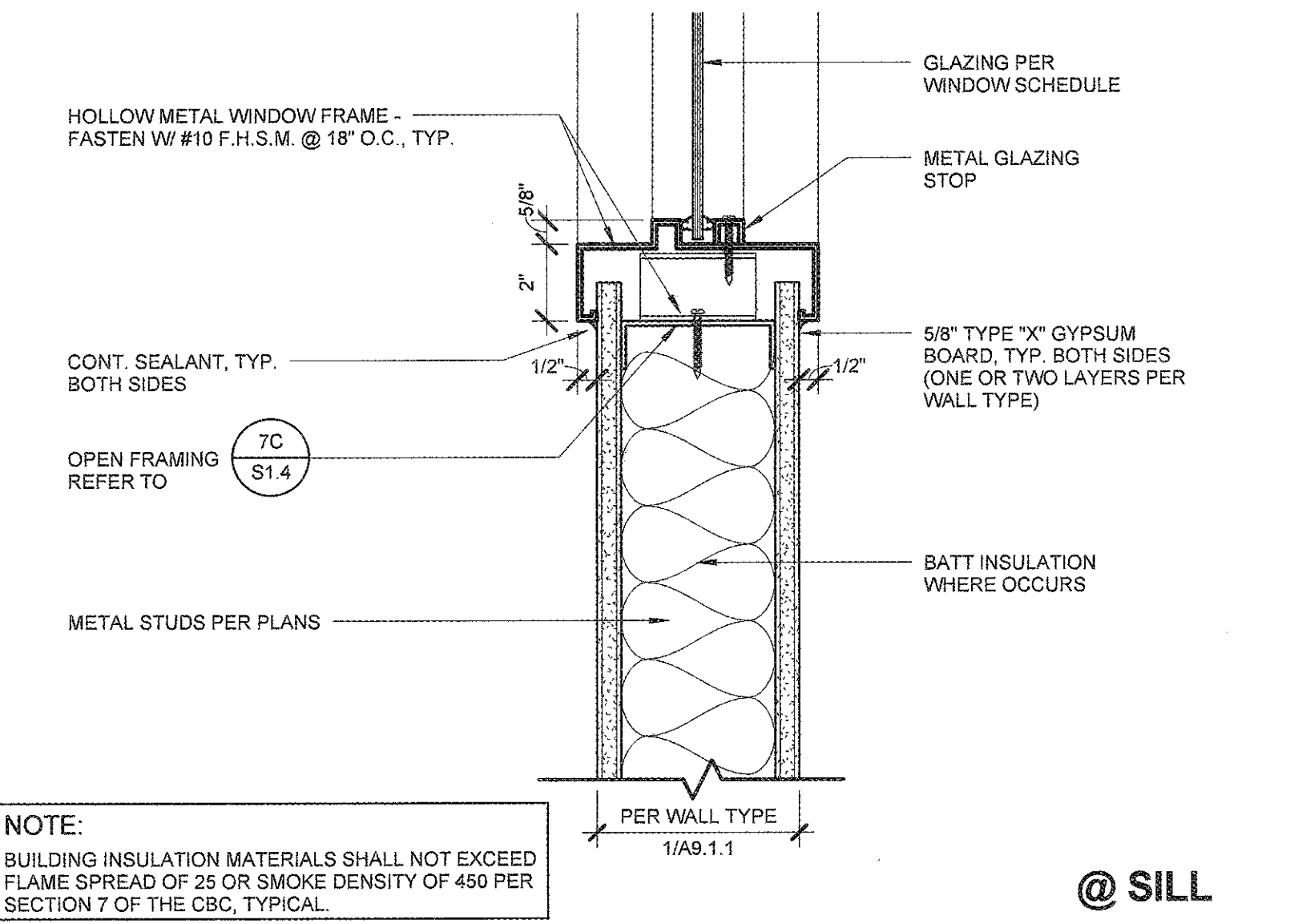

7 TYP. HOLLOW METAL FRAME WINDOW - SILL
A9.3.1 3" = 1'-0"



8 TYP. HOLLOW METAL FRAME WINDOW - SILL
A9.3.1 3" = 1'-0"

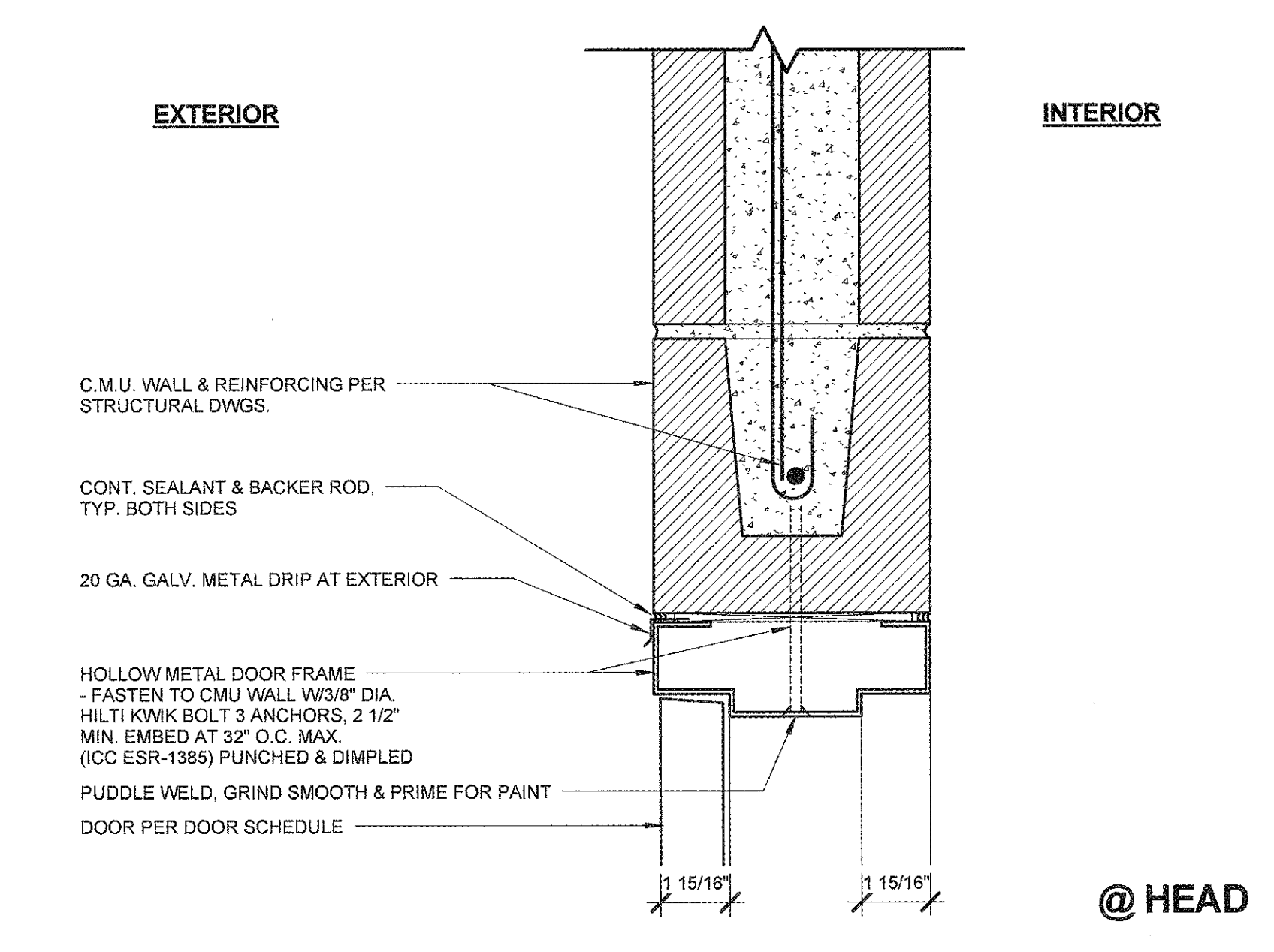

1 TYP. HOLLOW METAL DOOR FRAME AT C.M.U. WALL
A9.3.1 3" = 1'-0"

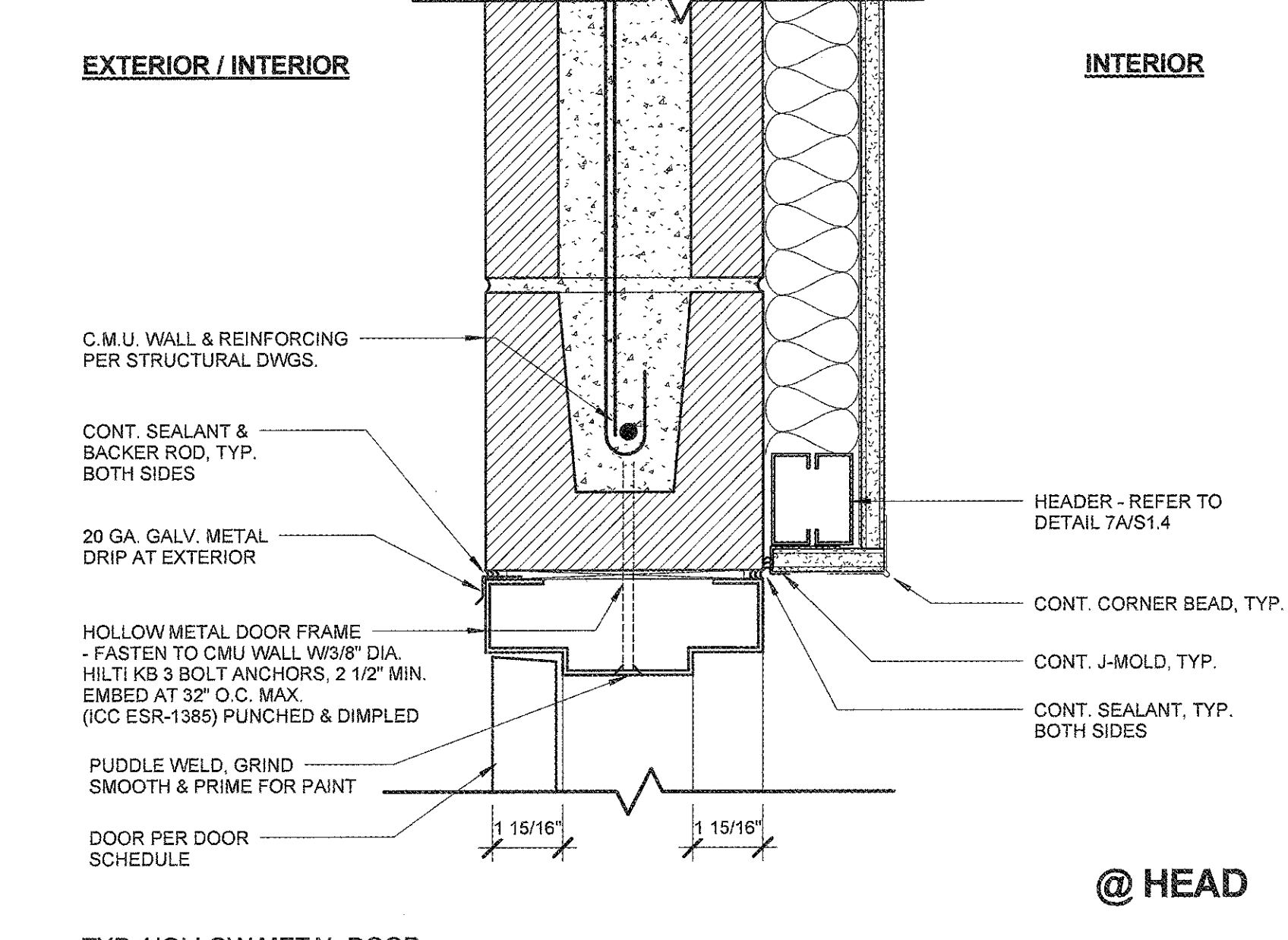

2 TYP. HOLLOW METAL DOOR FRAME AT C.M.U. WALL
A9.3.1 3" = 1'-0"

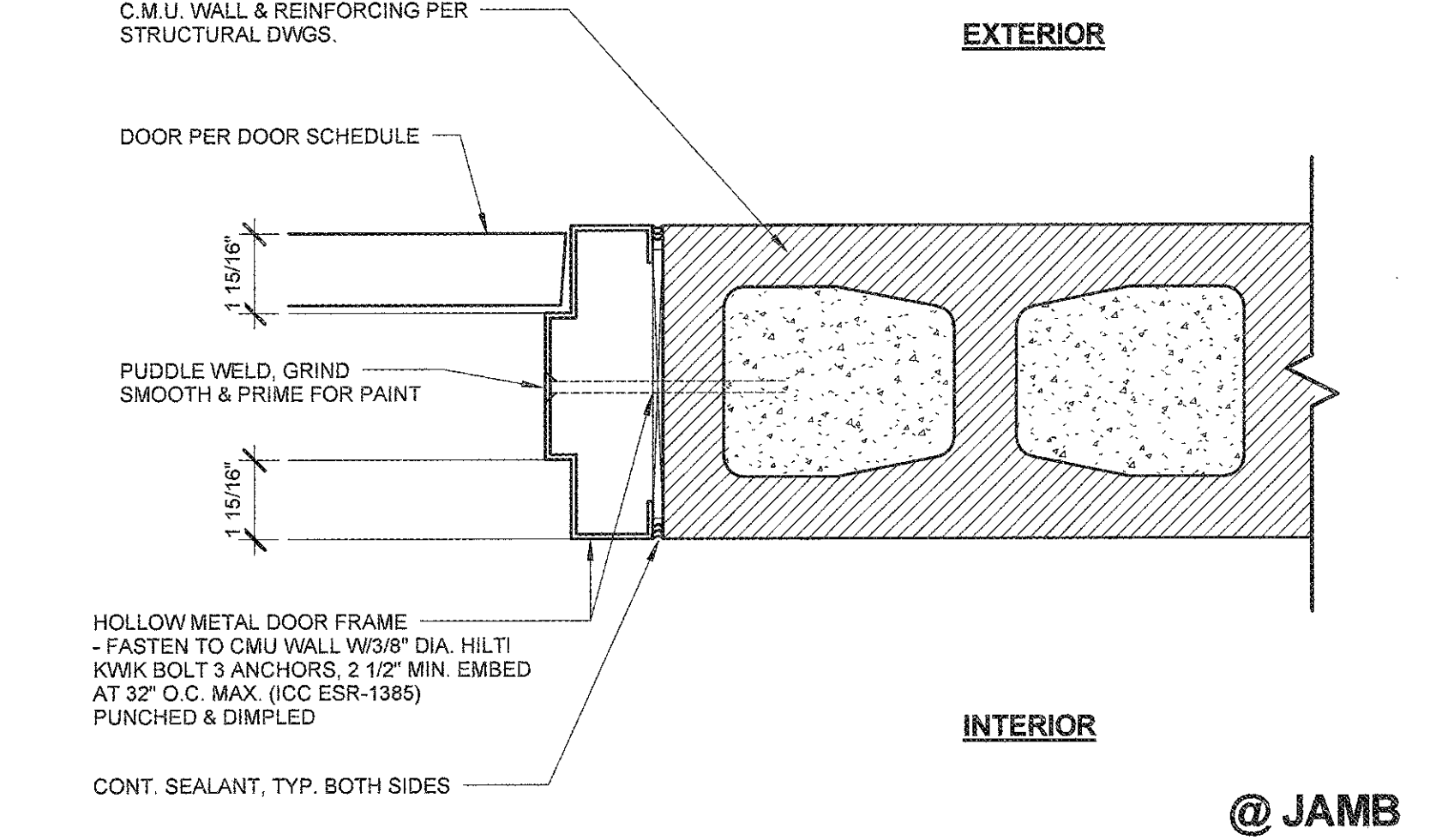

3 TYP. HOLLOW METAL DOOR FRAME AT C.M.U. WALL
A9.3.1 3" = 1'-0"

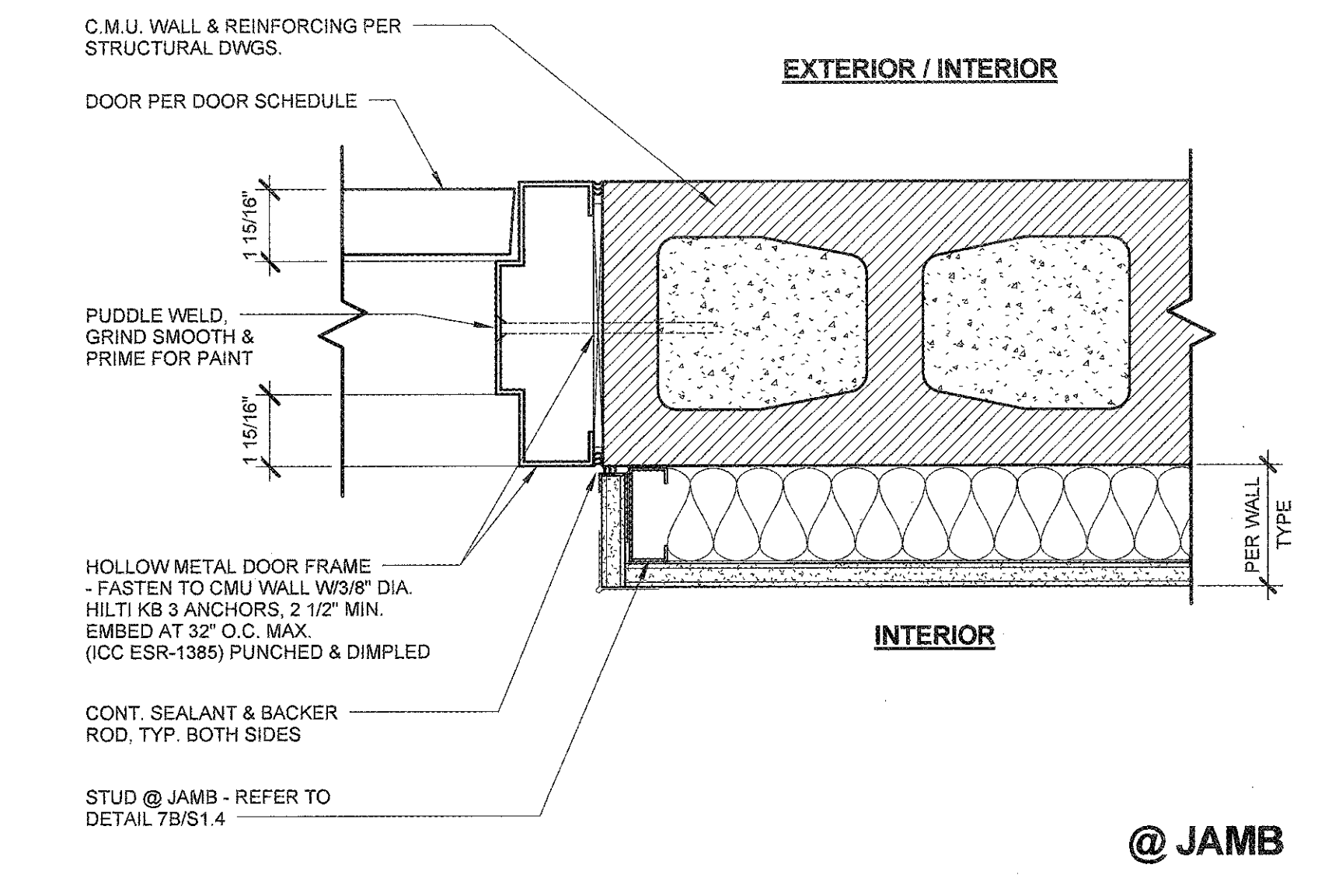

4 TYP. HOLLOW METAL DOOR FRAME AT C.M.U. WALL
A9.3.1 3" = 1'-0"

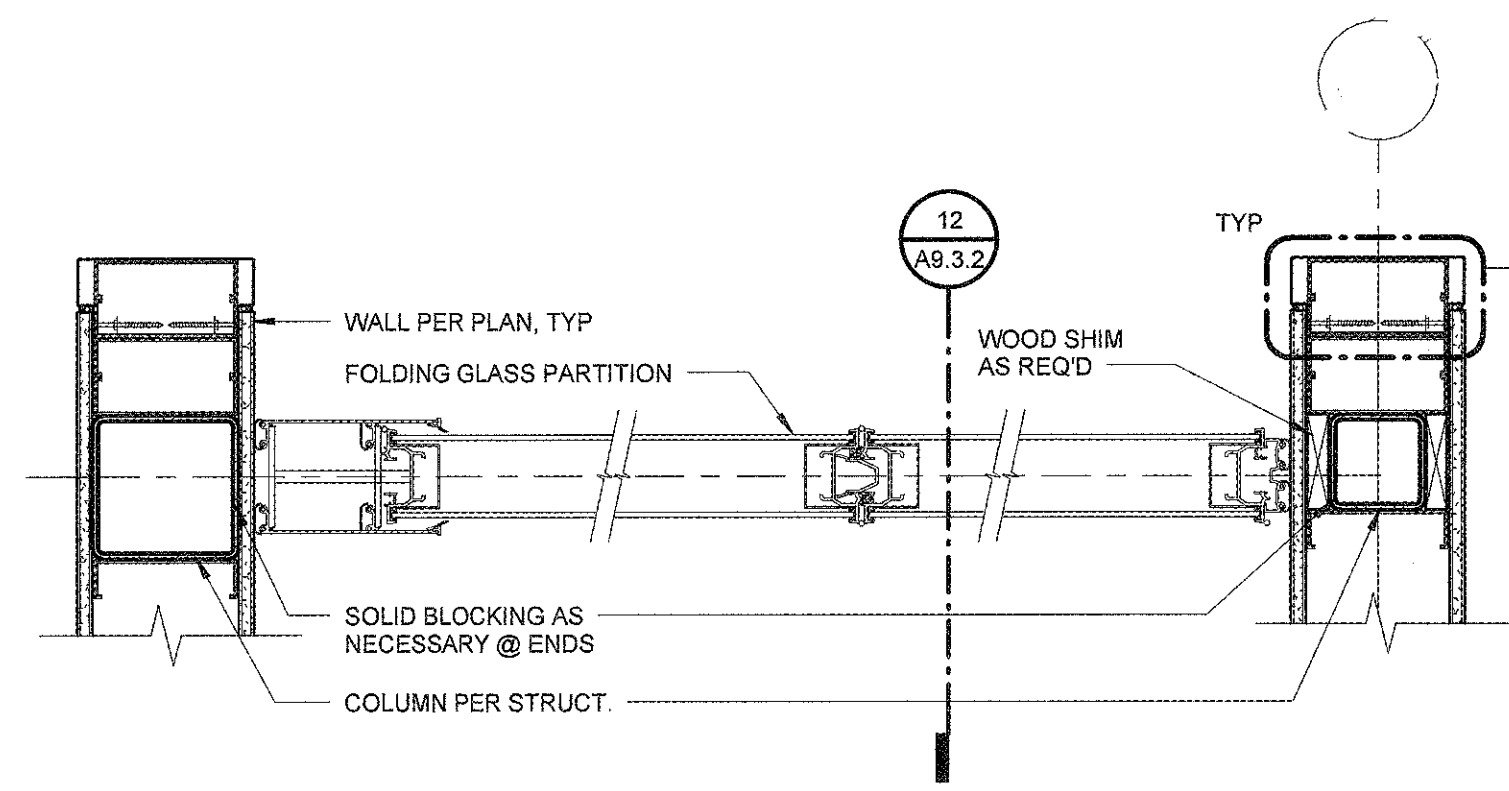

13 PARTITION @ JAMB
A9.3.2 1 1/2" = 1'-0"

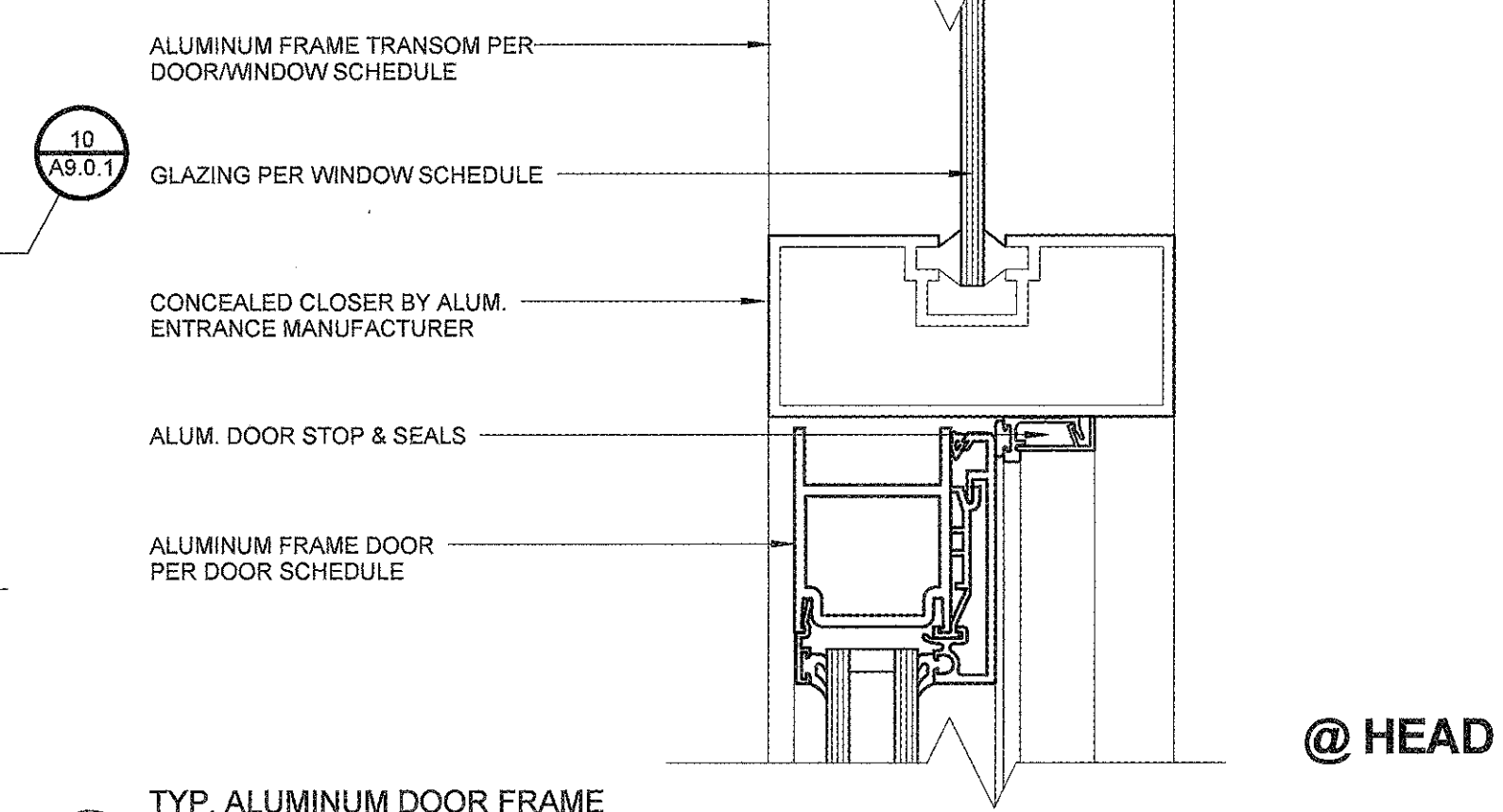

9 TYP. ALUMINUM DOOR FRAME AT TRANSOM
A9.3.2 6" = 1'-0"

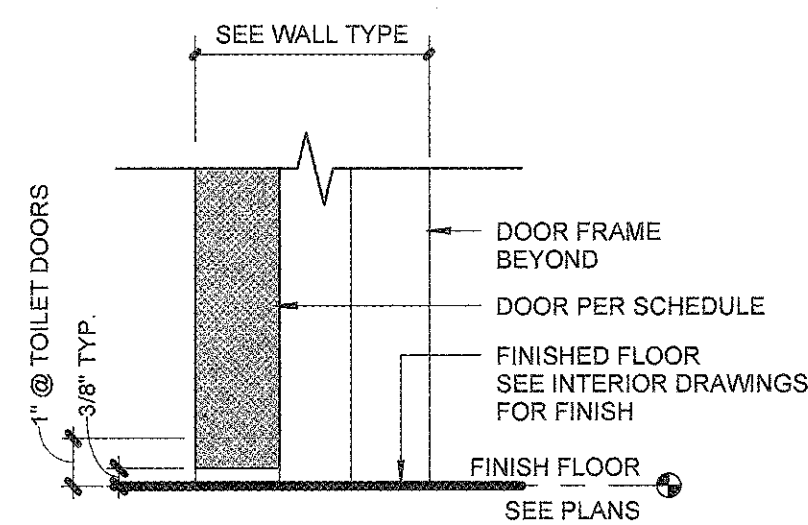

14 INTERIOR DOOR UNDERCUT
A9.3.2 3" = 1'-0"

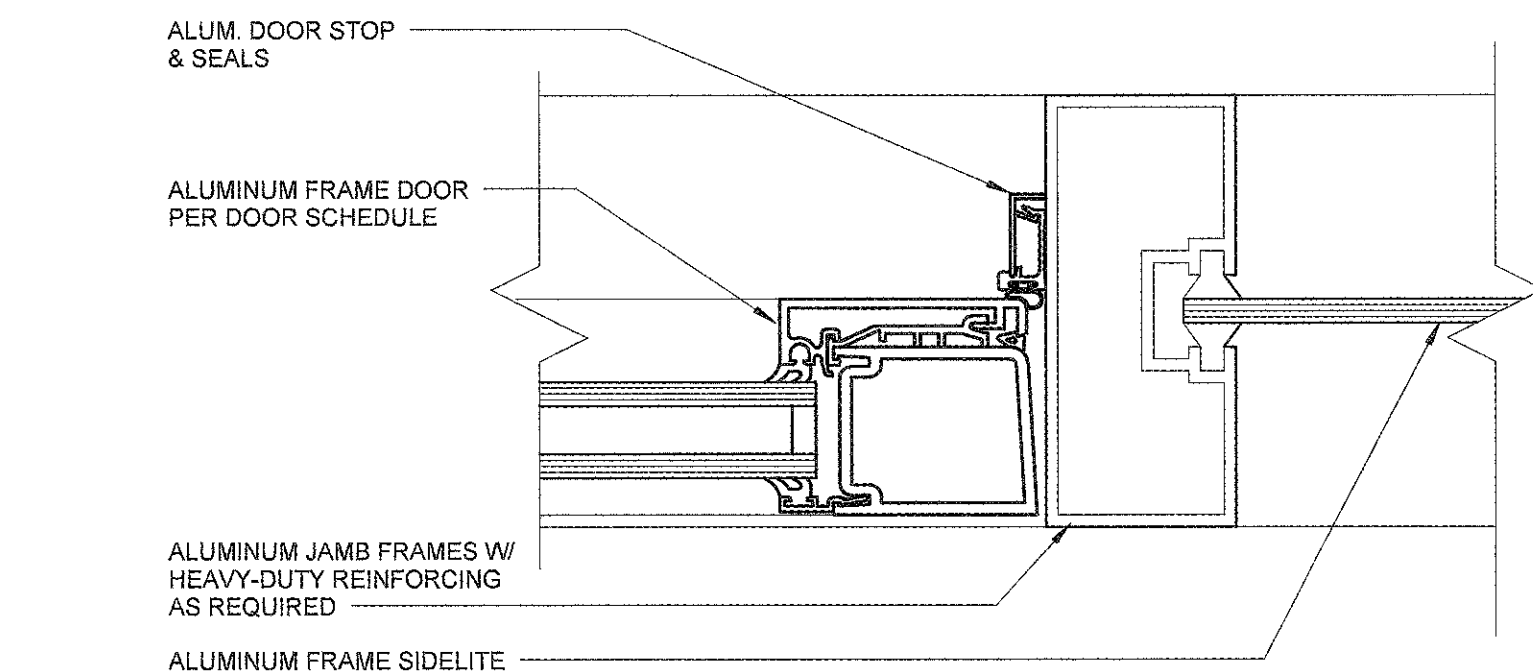

10 TYP. ALUMINUM DOOR FRAME AT SIDELITE
A9.3.2 6" = 1'-0"

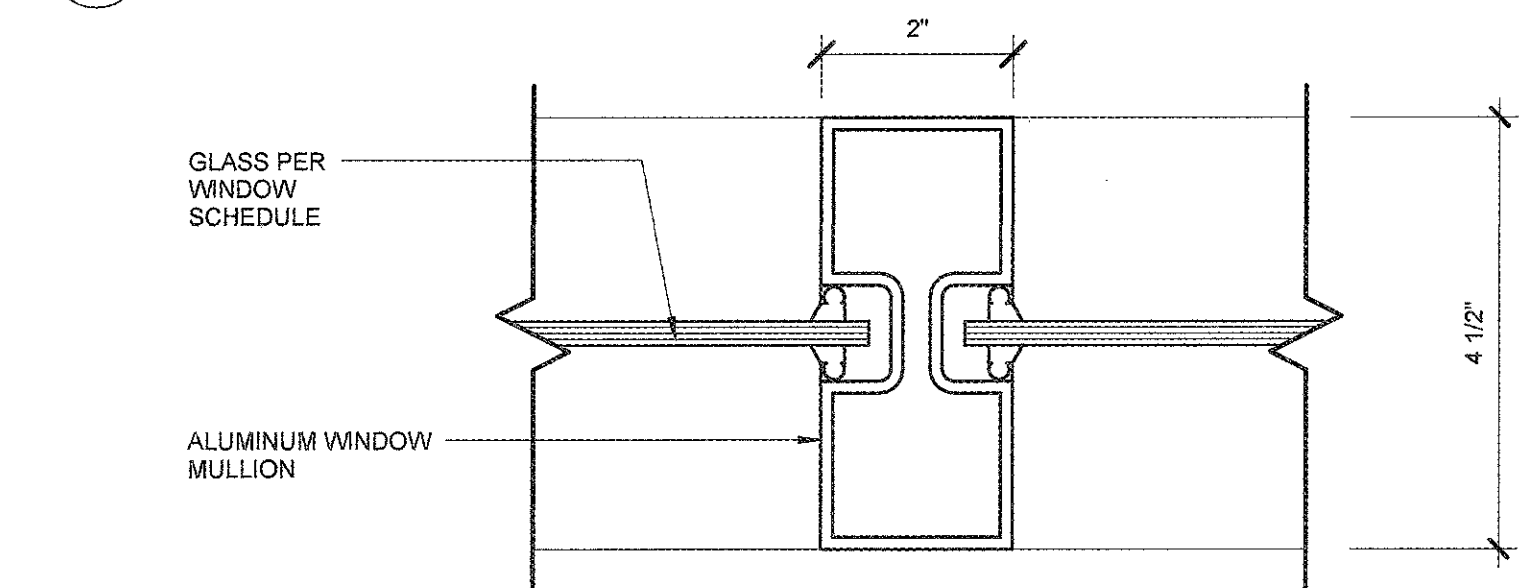

11 TYP. WINDOW FRAME MULLION
A9.3.2 6" = 1'-0"

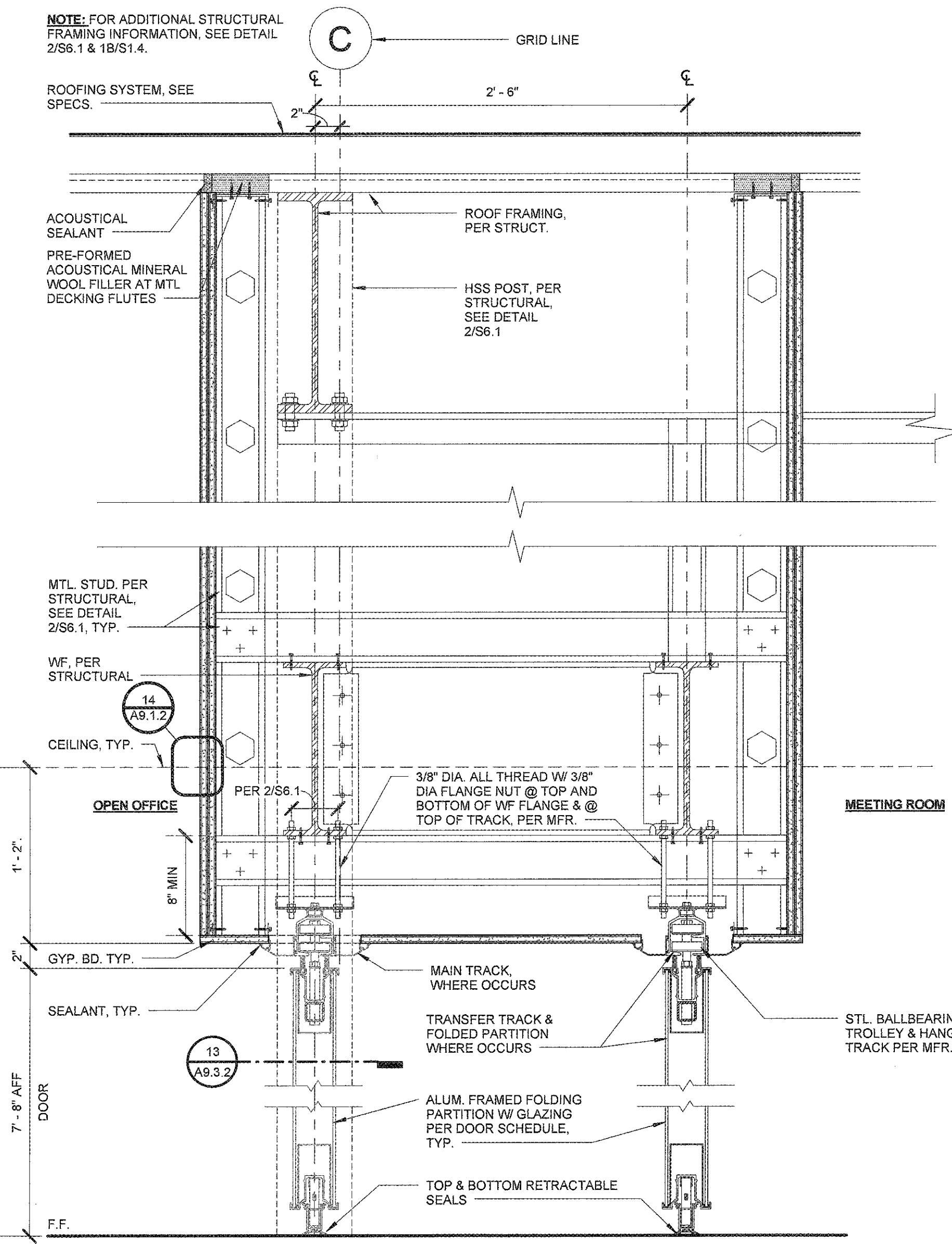

12 ALUM. FRAMED GLASS PARTITION SUPPORT
A9.3.2 1 1/2" = 1'-0"

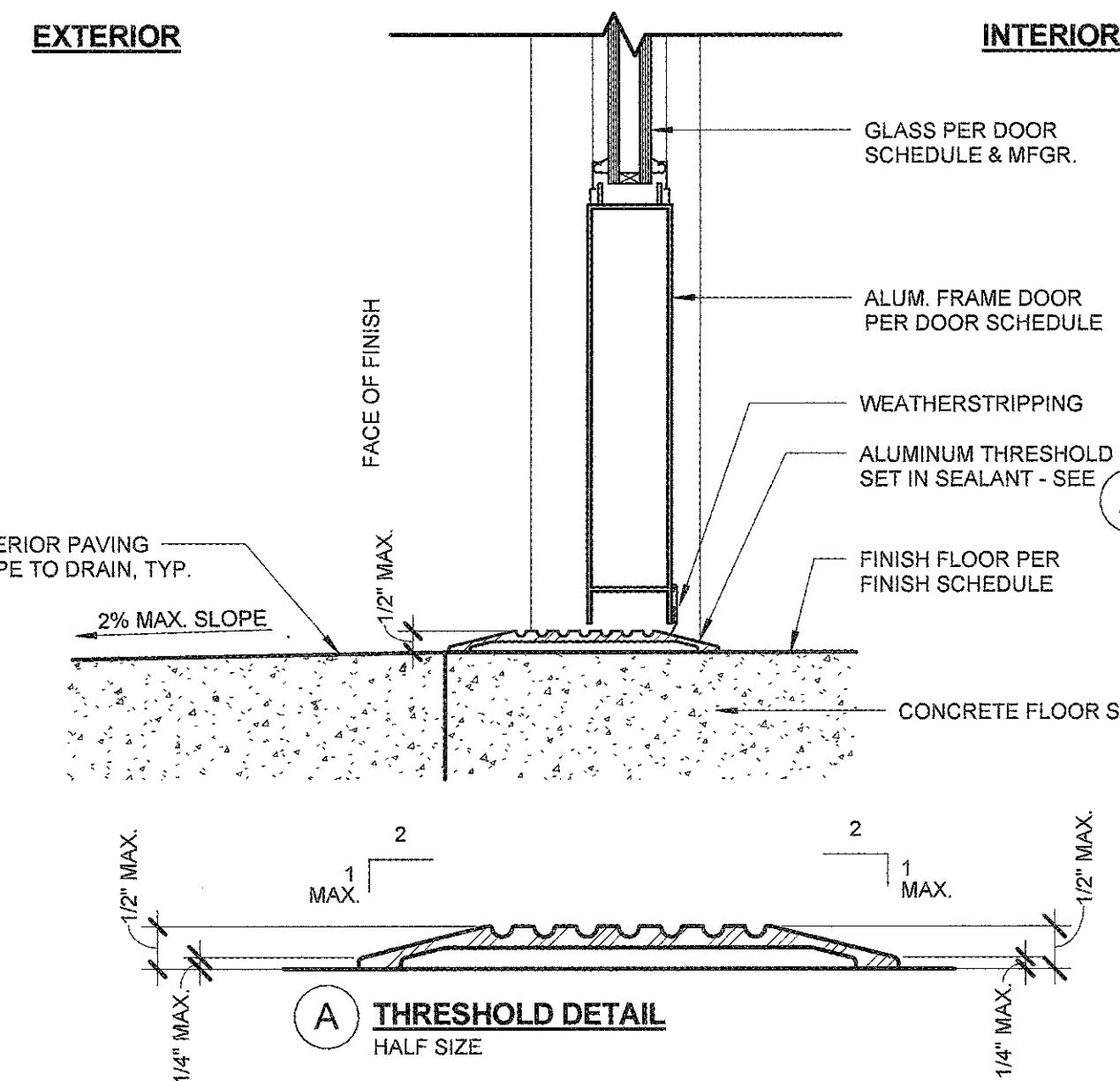

5 TYP. THRESHOLD AT ALUMINUM DOOR
A9.3.2 3" = 1'-0"

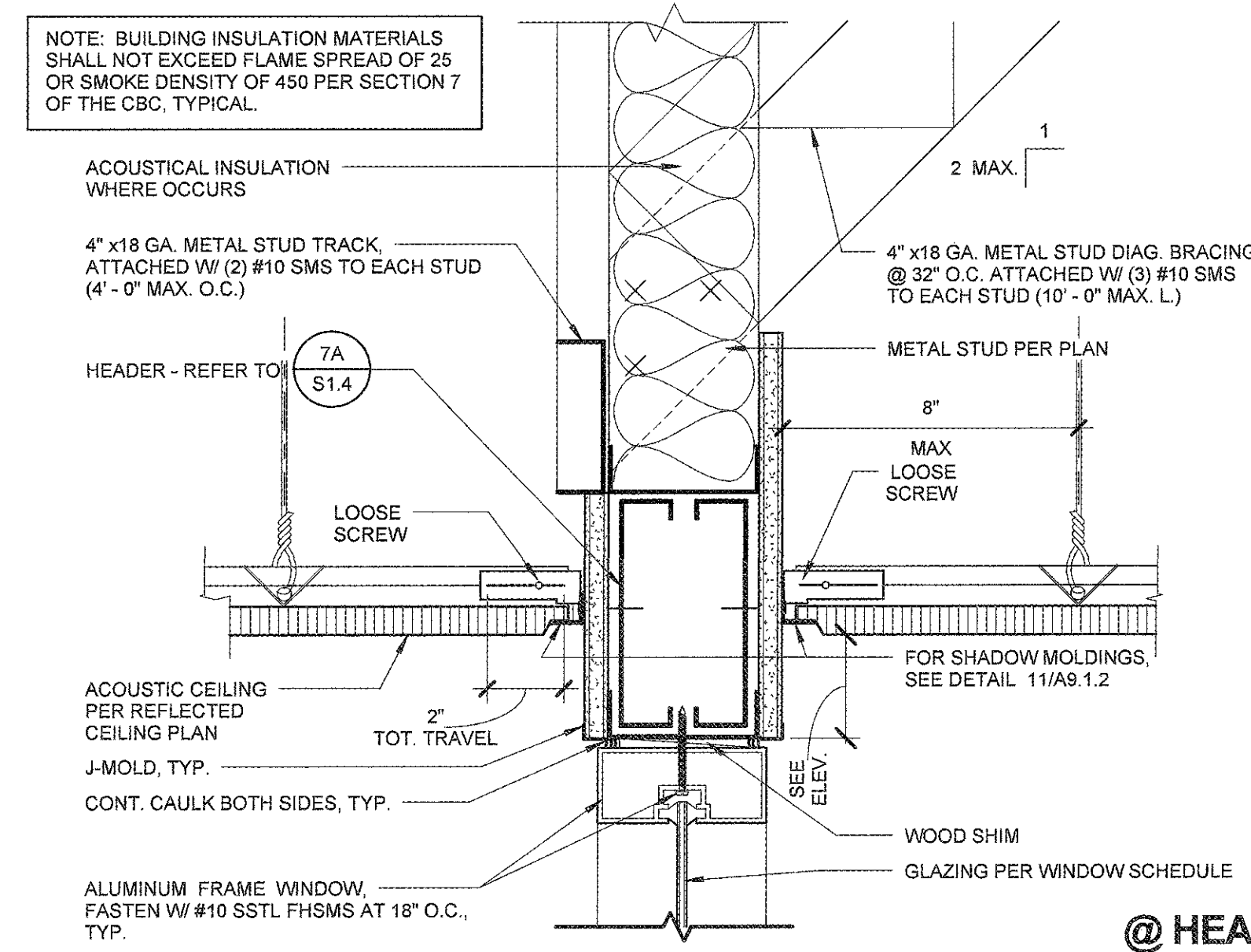

6 TYP. INTERIOR ALUMINUM FRAMED WINDOW
A9.3.2 3" = 1'-0"

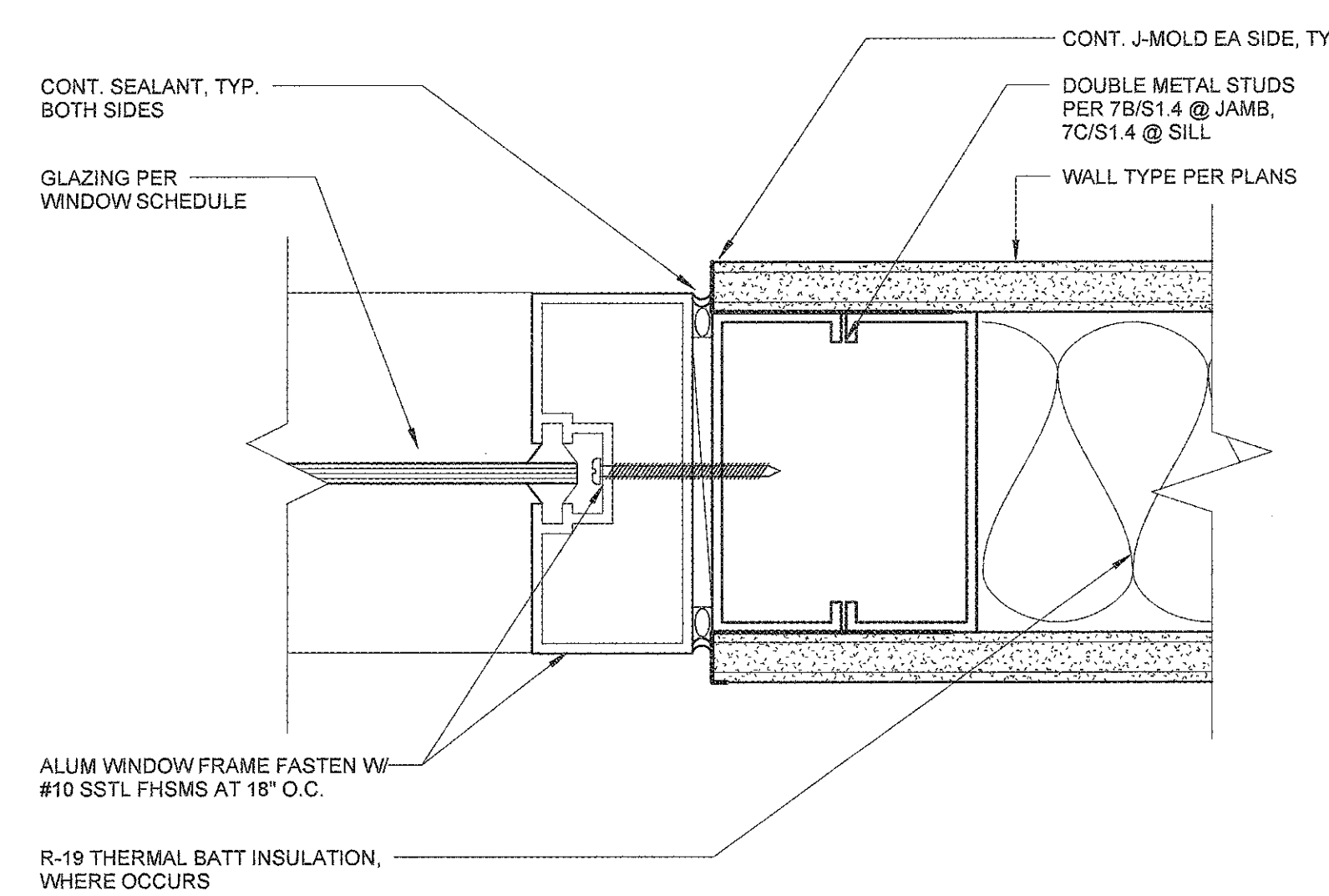

7 TYP. ALUMINUM FRAME SIDELITE - JAMB
A9.3.2 6" = 1'-0"

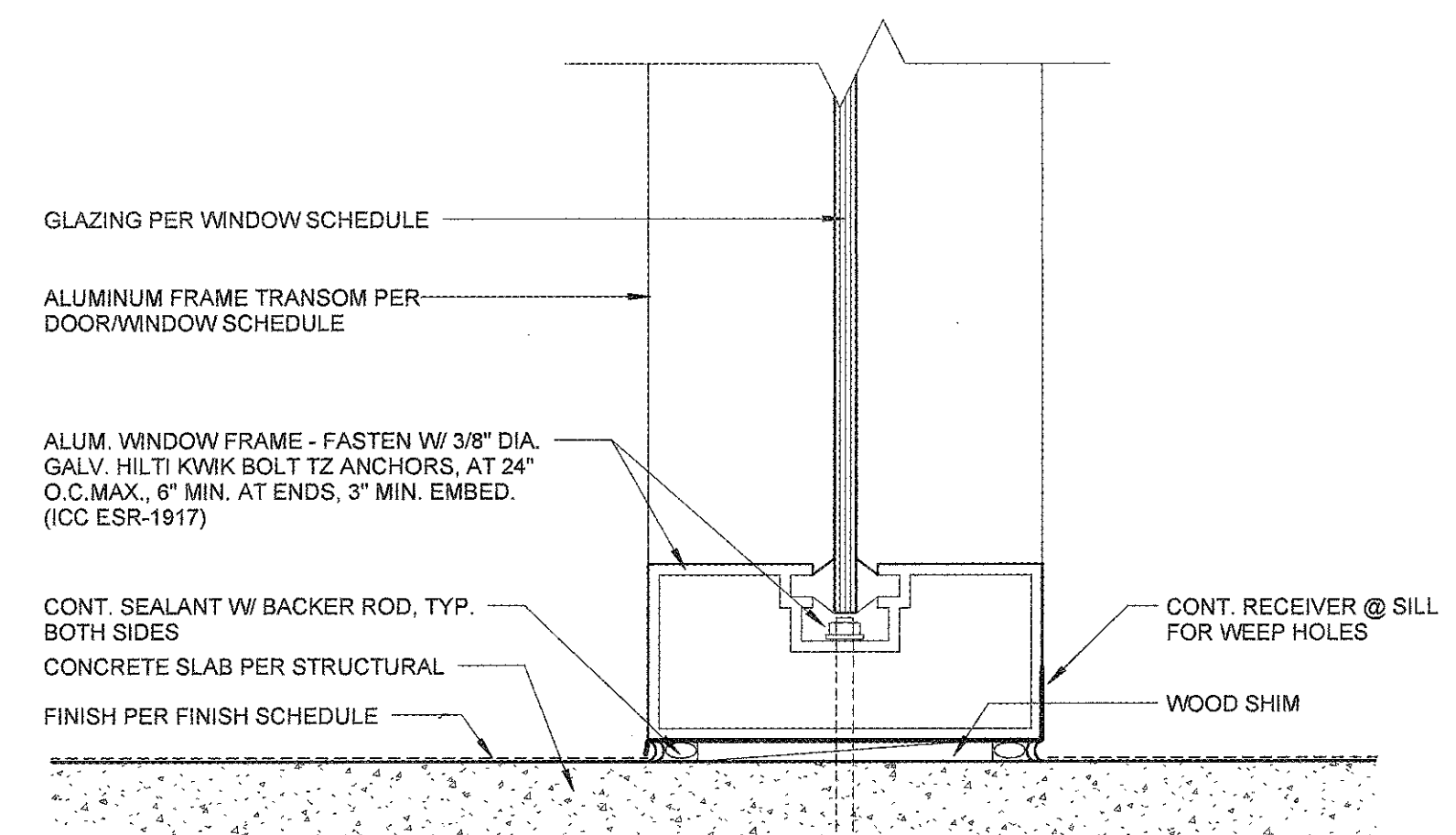

8 TYP. ALUMINUM FRAME AT CONCRETE SLAB
A9.3.2 6" = 1'-0"

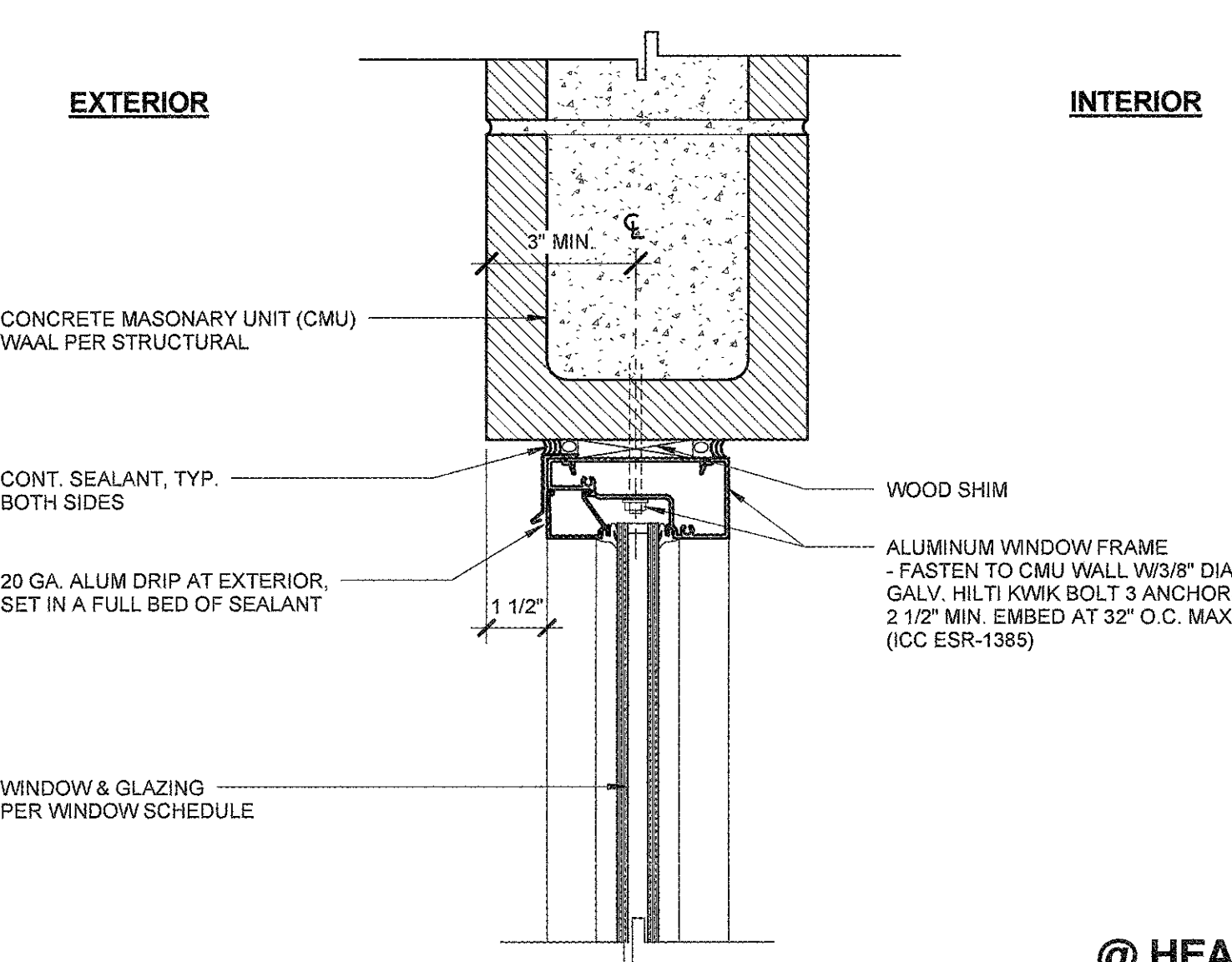

1 TYP. ALUM. WINDOW AT CMU WALL
A9.3.2 3" = 1'-0"

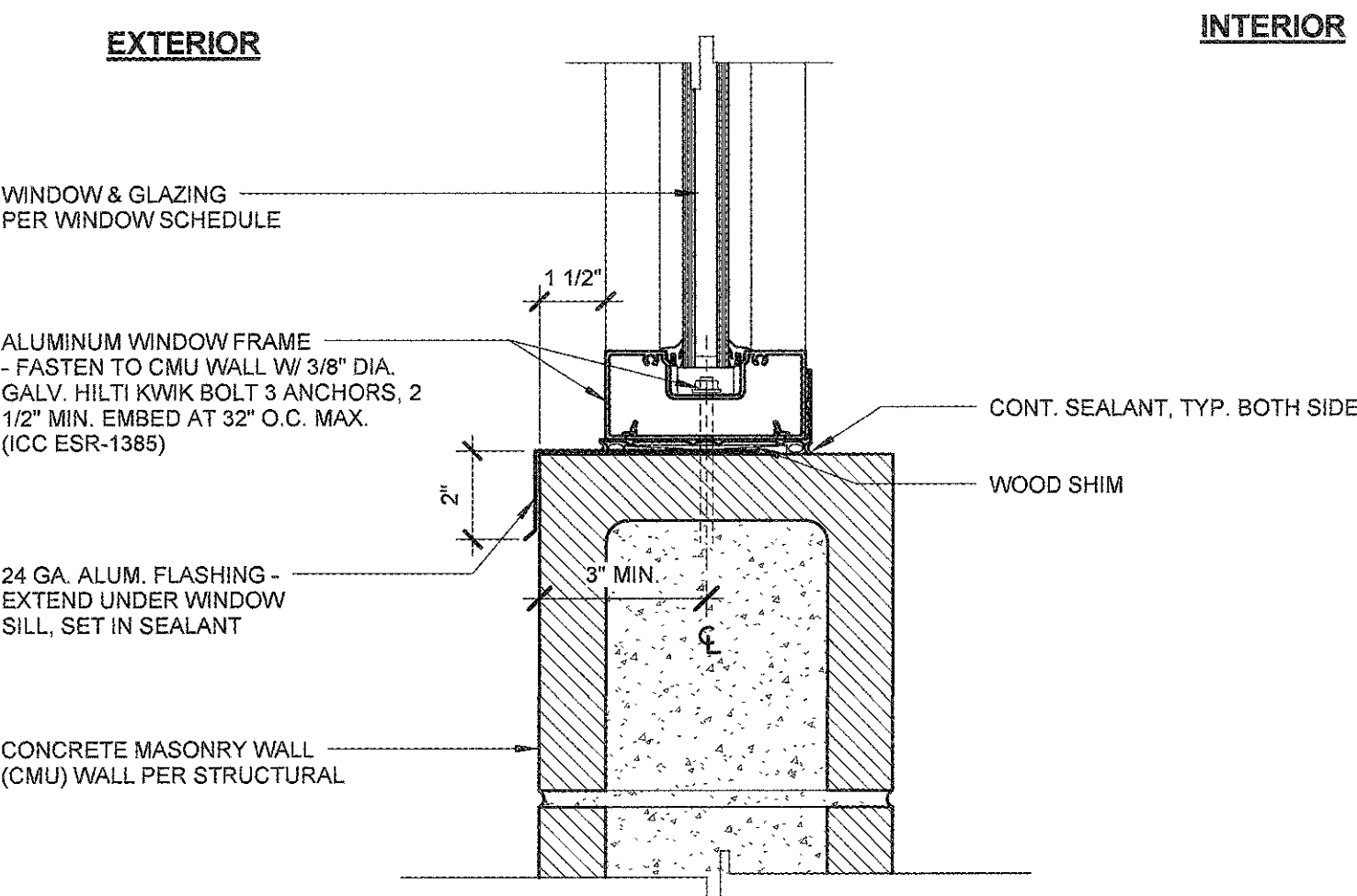

2 TYP. ALUM. WINDOW AT CMU WALL
A9.3.2 3" = 1'-0"

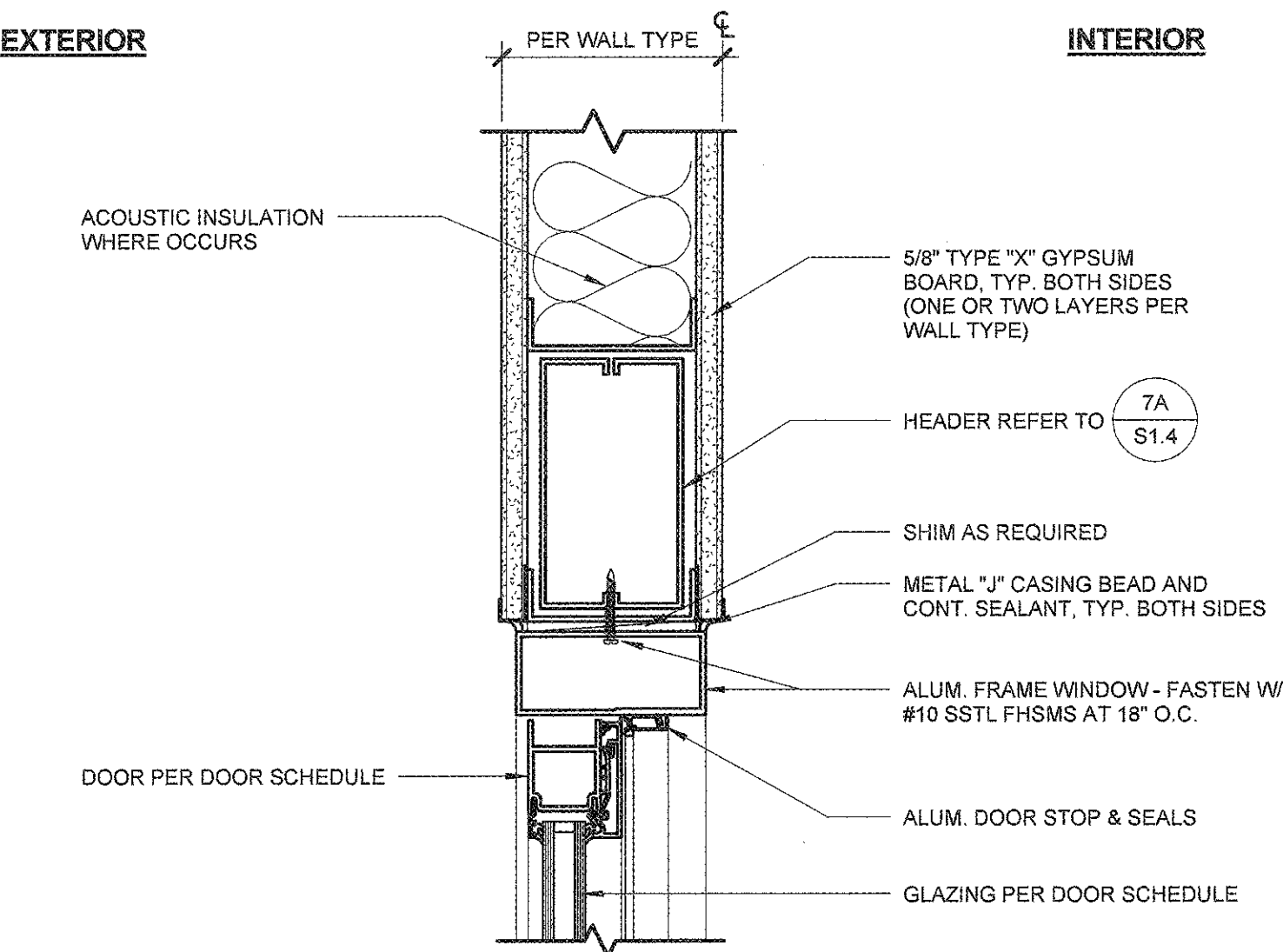

3 TYP. INTERIOR ALUMINUM FRAME DOOR
A9.3.2 3" = 1'-0"

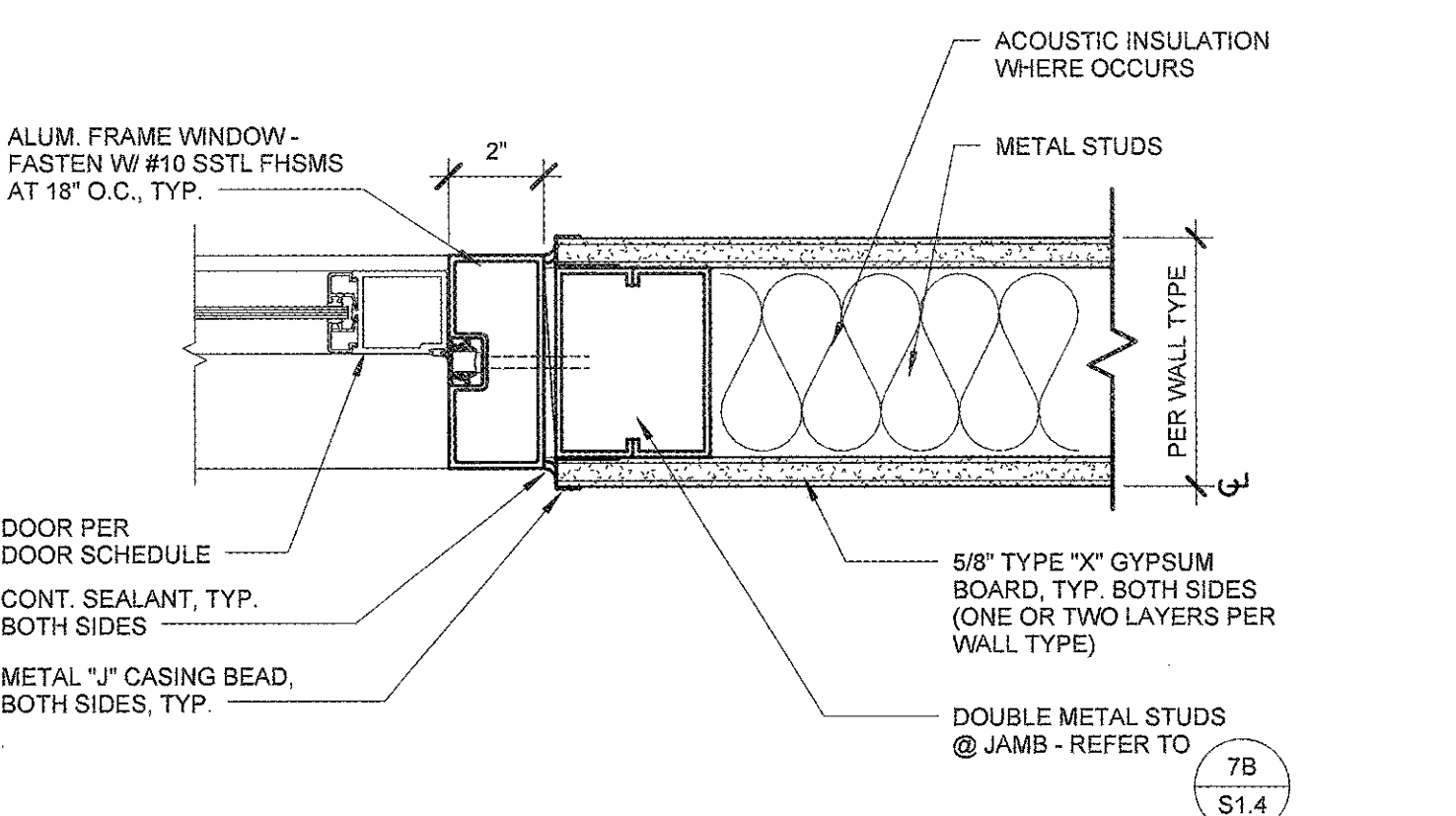

4 TYP. INTERIOR ALUMINUM FRAME DOOR
A9.3.2 3" = 1'-0"

LITTLE
GIVERSBERG ARCHITECTURAL CONSULTING

1300 Dove Street, Suite 100
Newport Beach, CA 92660
T: 949.698.1400 F: 949.698.1433
www.littleonline.com

This drawing and the design shown are the property of Little Diversified Architectural Consulting. The reproduction, copying or other use of this drawing without their written consent is prohibited and any infringement will be subject to legal action.

© Little 2016

COMPTON CCD

PROJECT NAME
CAMPUS PUBLIC SAFETY BUILDING

1111 EAST ARTESIA BOULEVARD,
COMPTON CALIFORNIA 90221

IDENTIFICATION STAMP
DIV. OF THE STATE ARCHITECT
OFFICE OF REGULATION SERVICES

FILE NO: 19-C1
AR: 03-117673

DATE: DEC 17, 2017

CONSULTANT

PRINCIPAL IN CHARGE
RITA S. CARTER

PROJECT MANAGER
SHOJI TAKESHIMA / DAVID PHAN

DRAWN BY
DAVID PHAN

REVISIONS

NO	REASON	DATE

ISSUED TITLE
ALUMINUM DOOR & WINDOW DETAILS

PROJECT NUMBER
913-4675-00

DATE
12/01/16

REV. NO.
A9.3.2

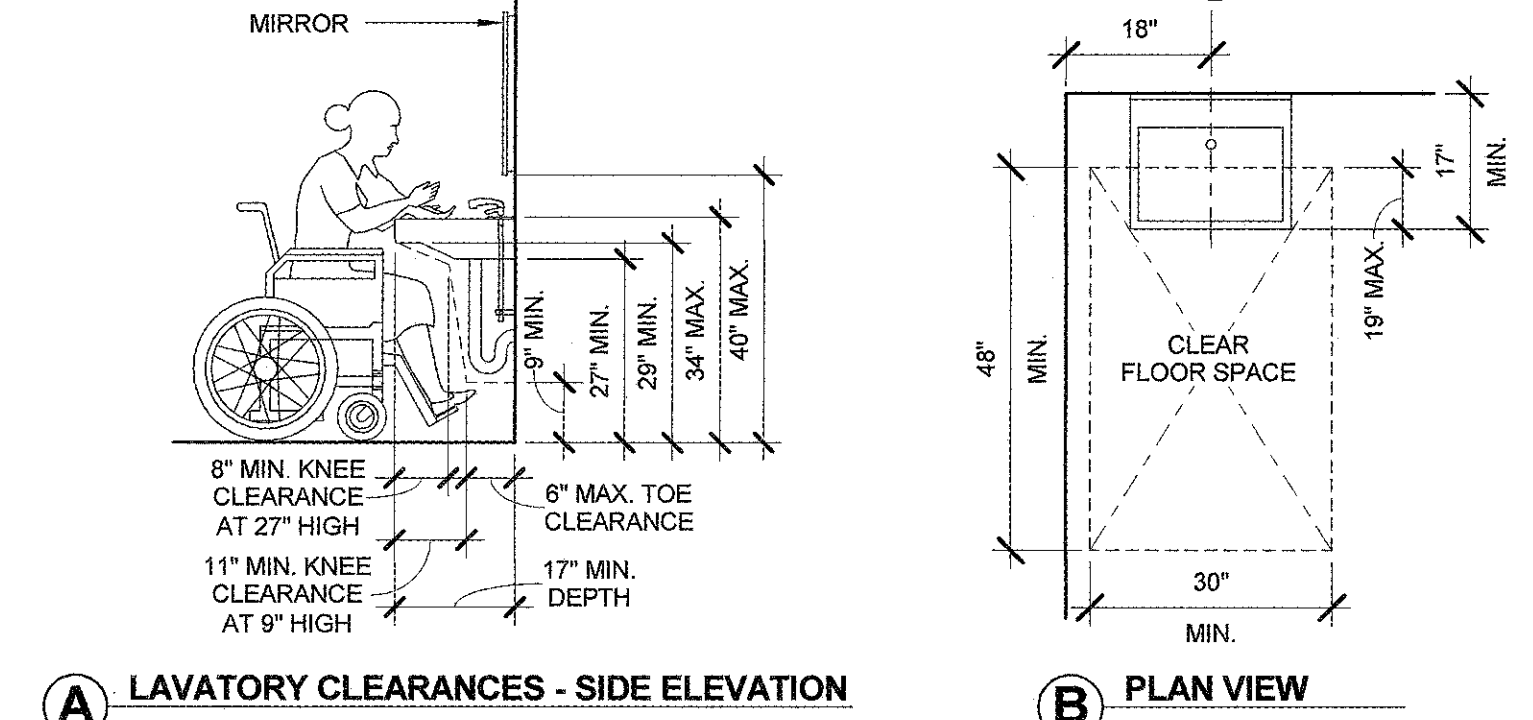
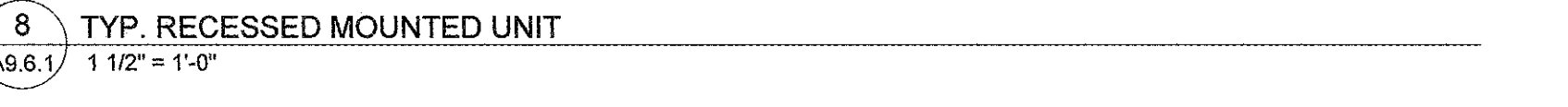
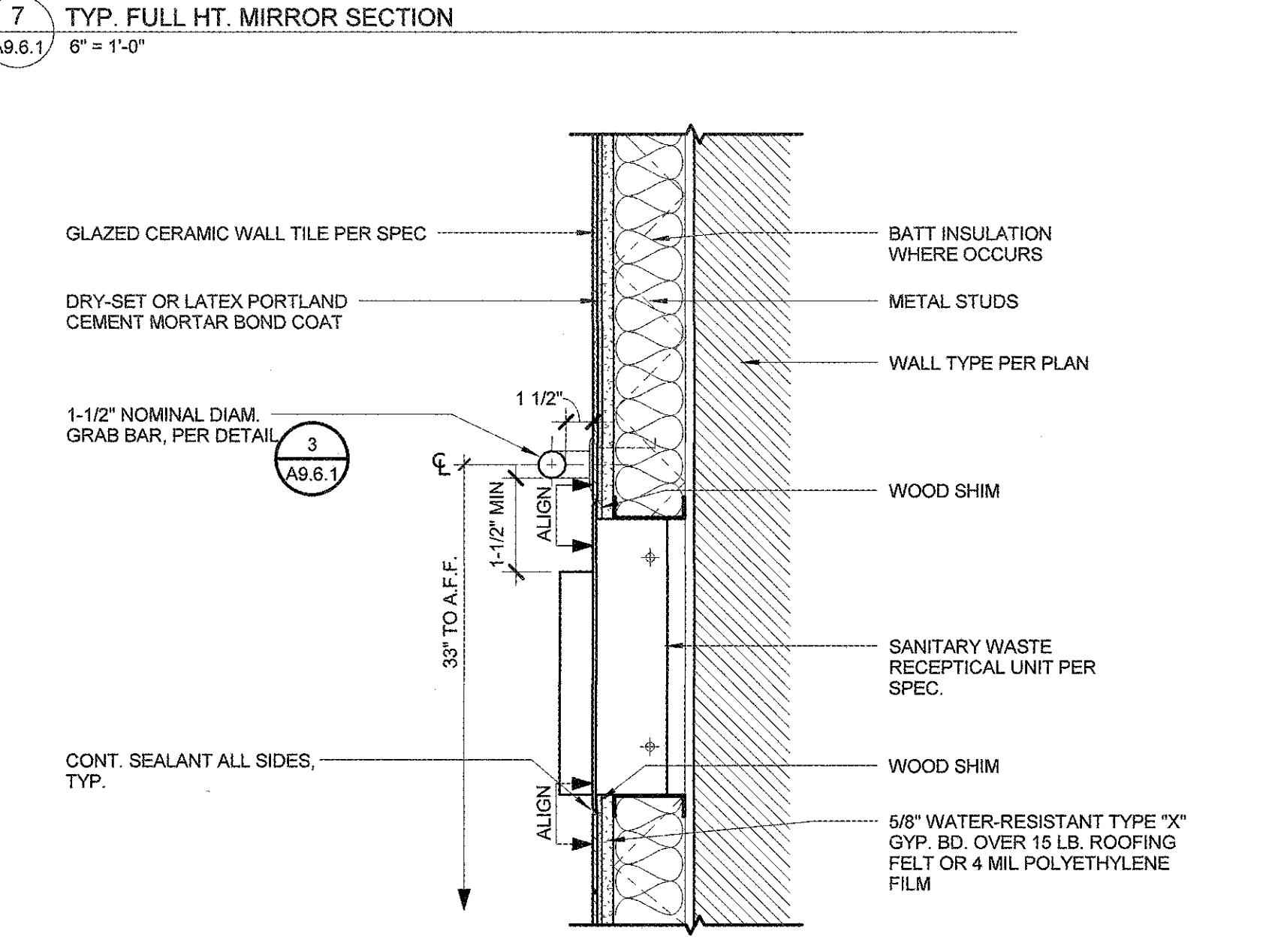
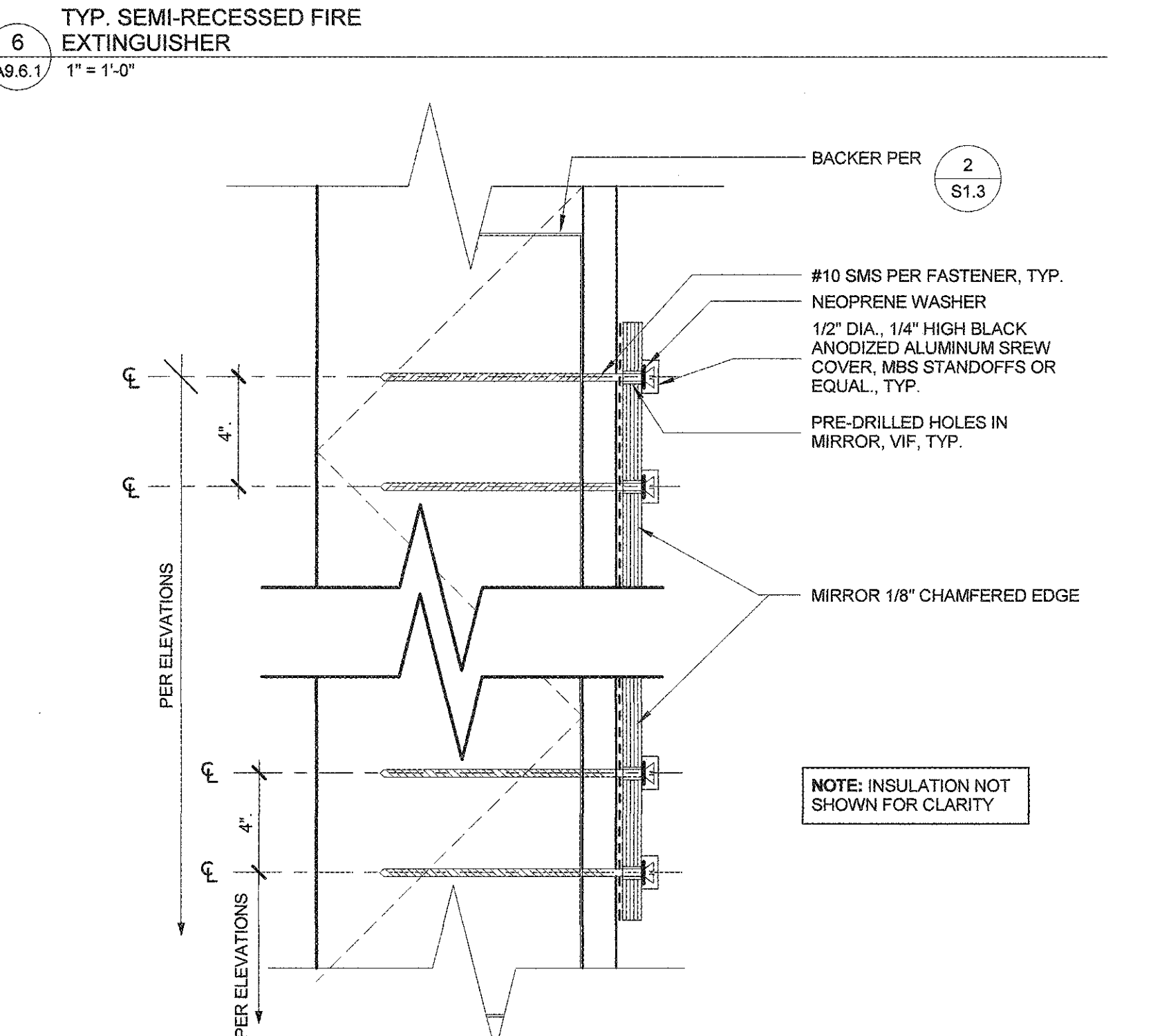
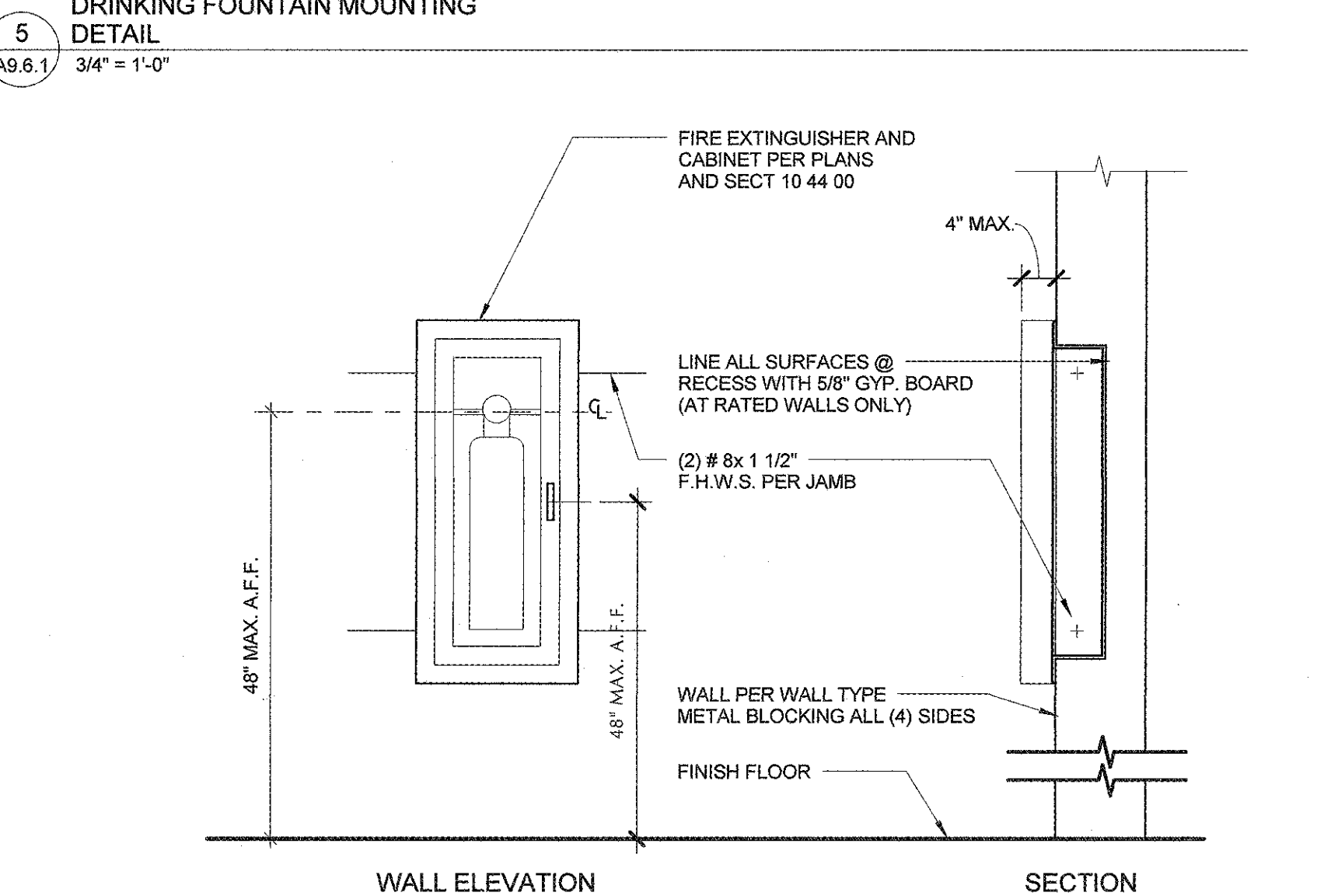
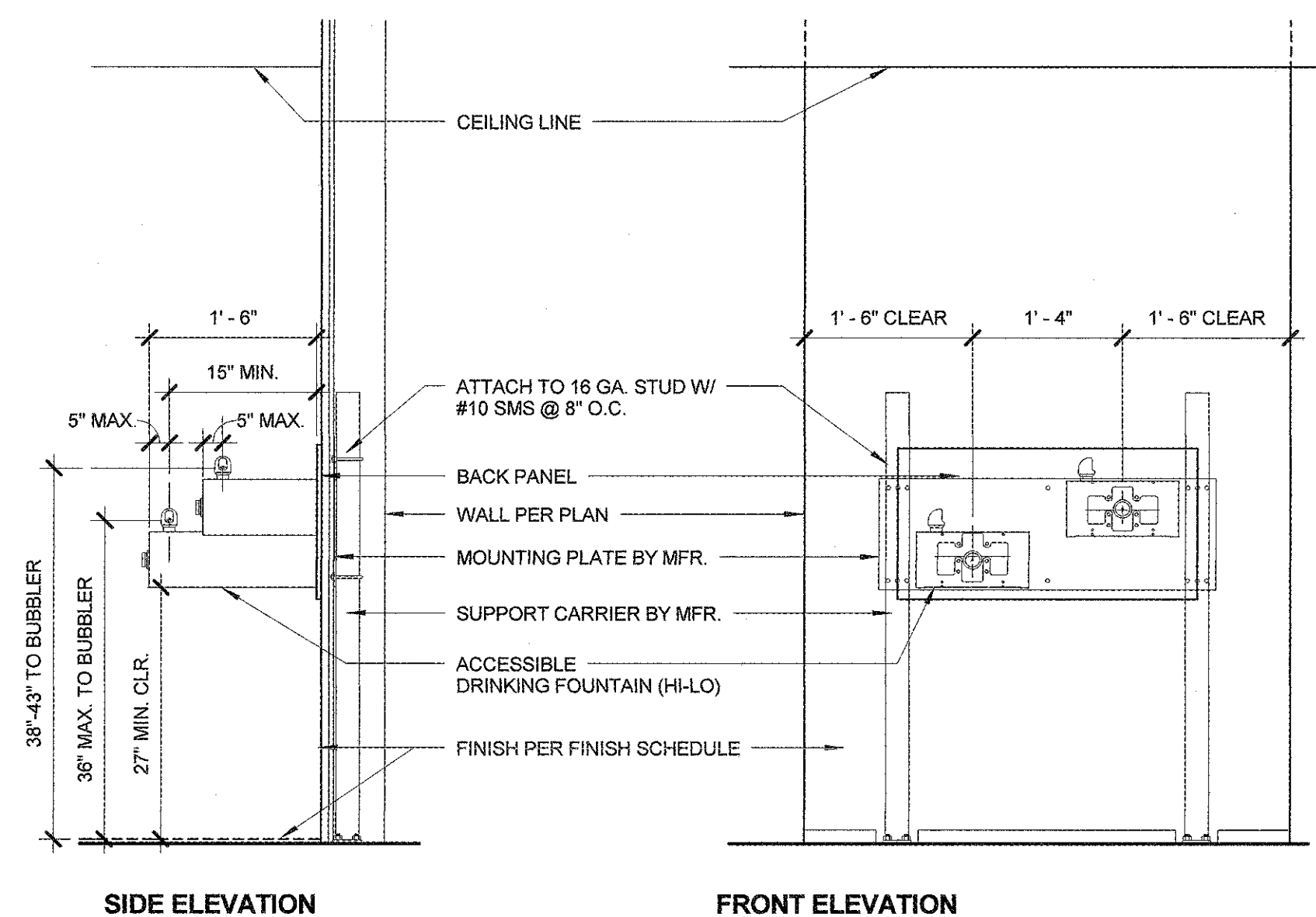
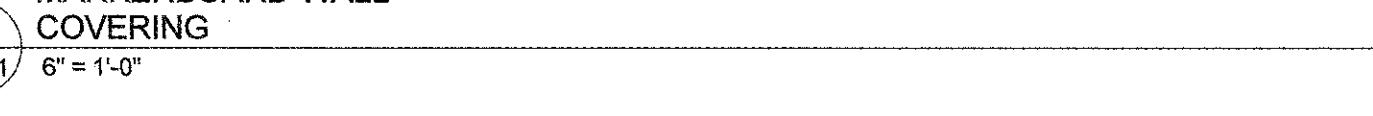
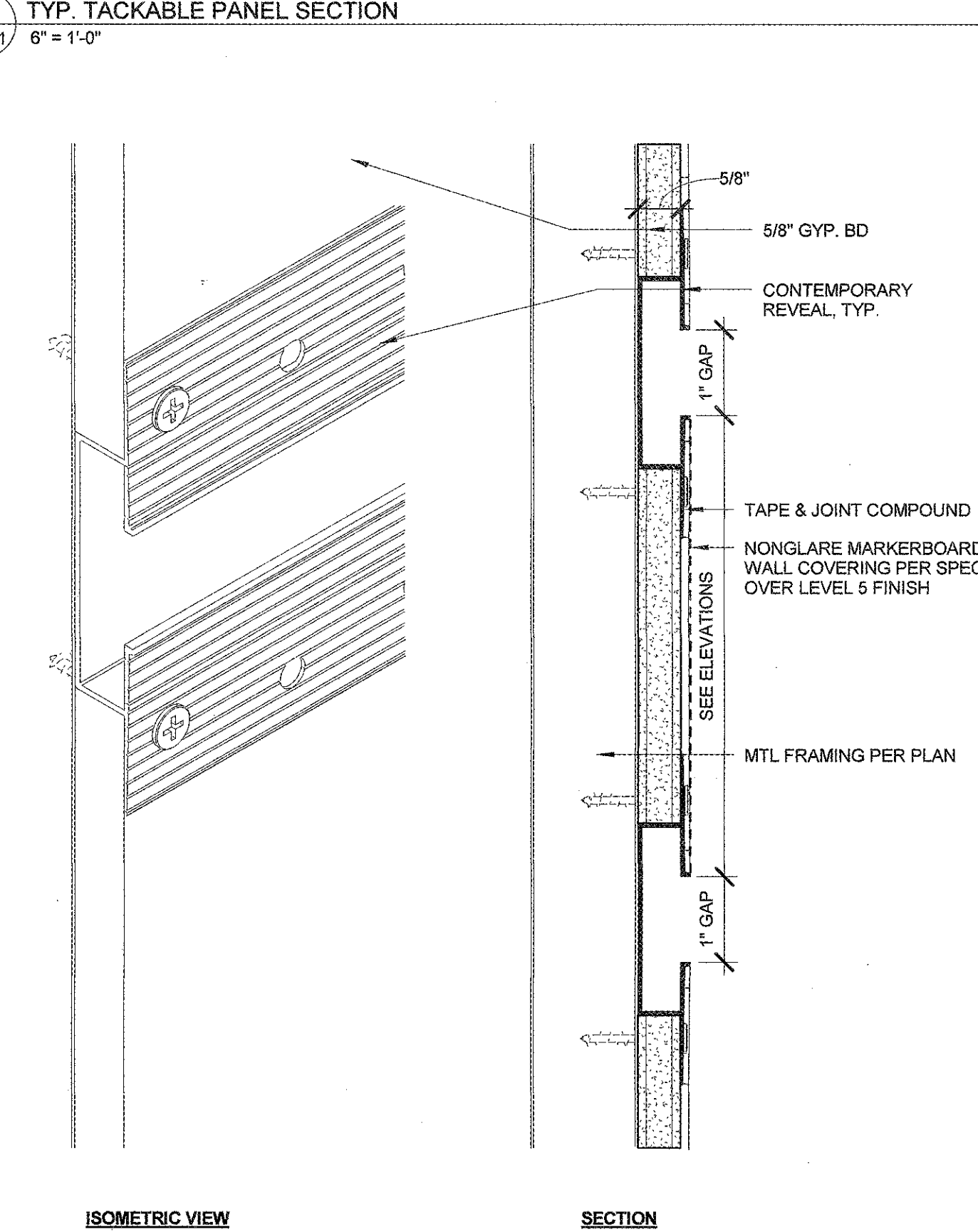
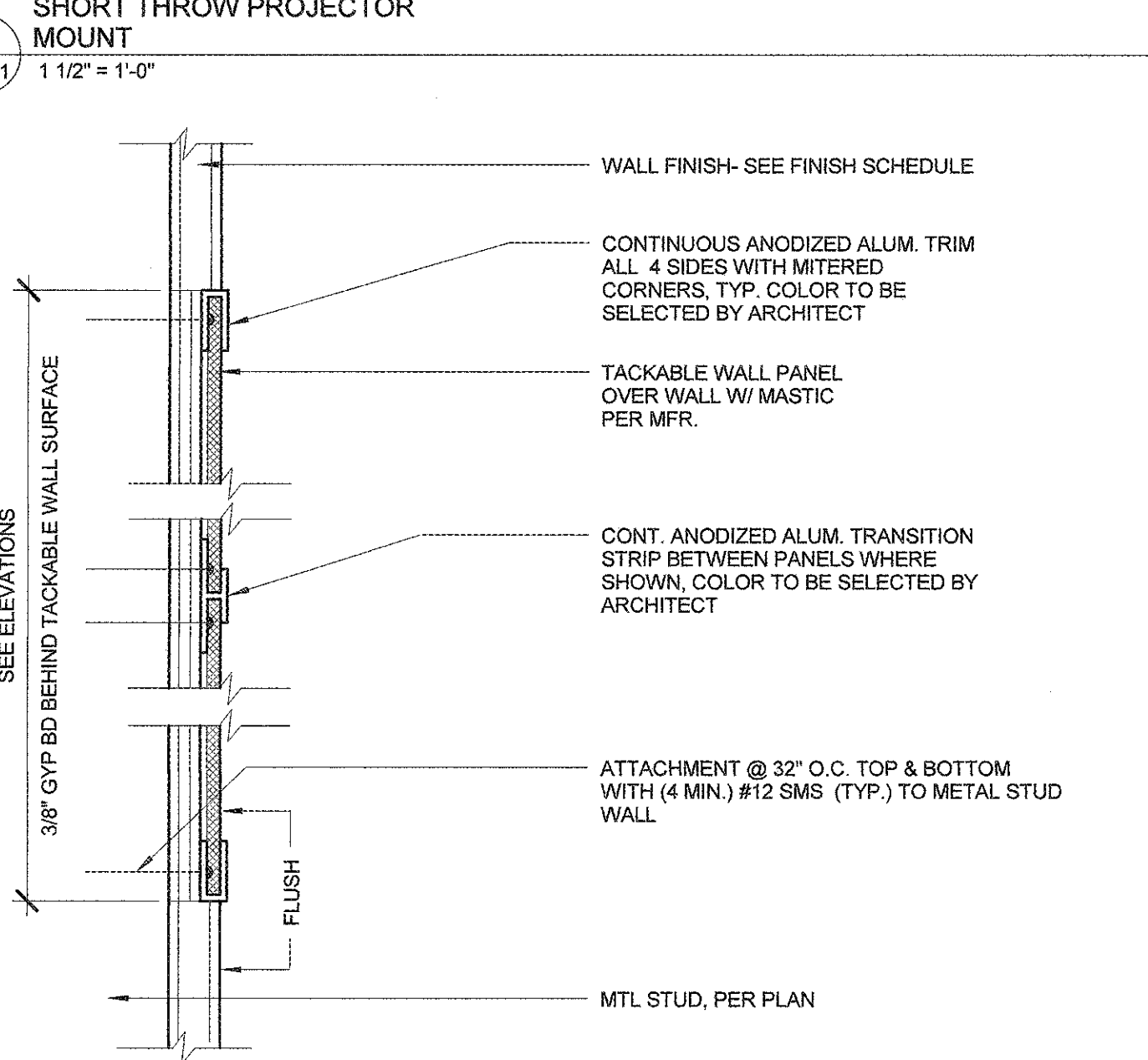
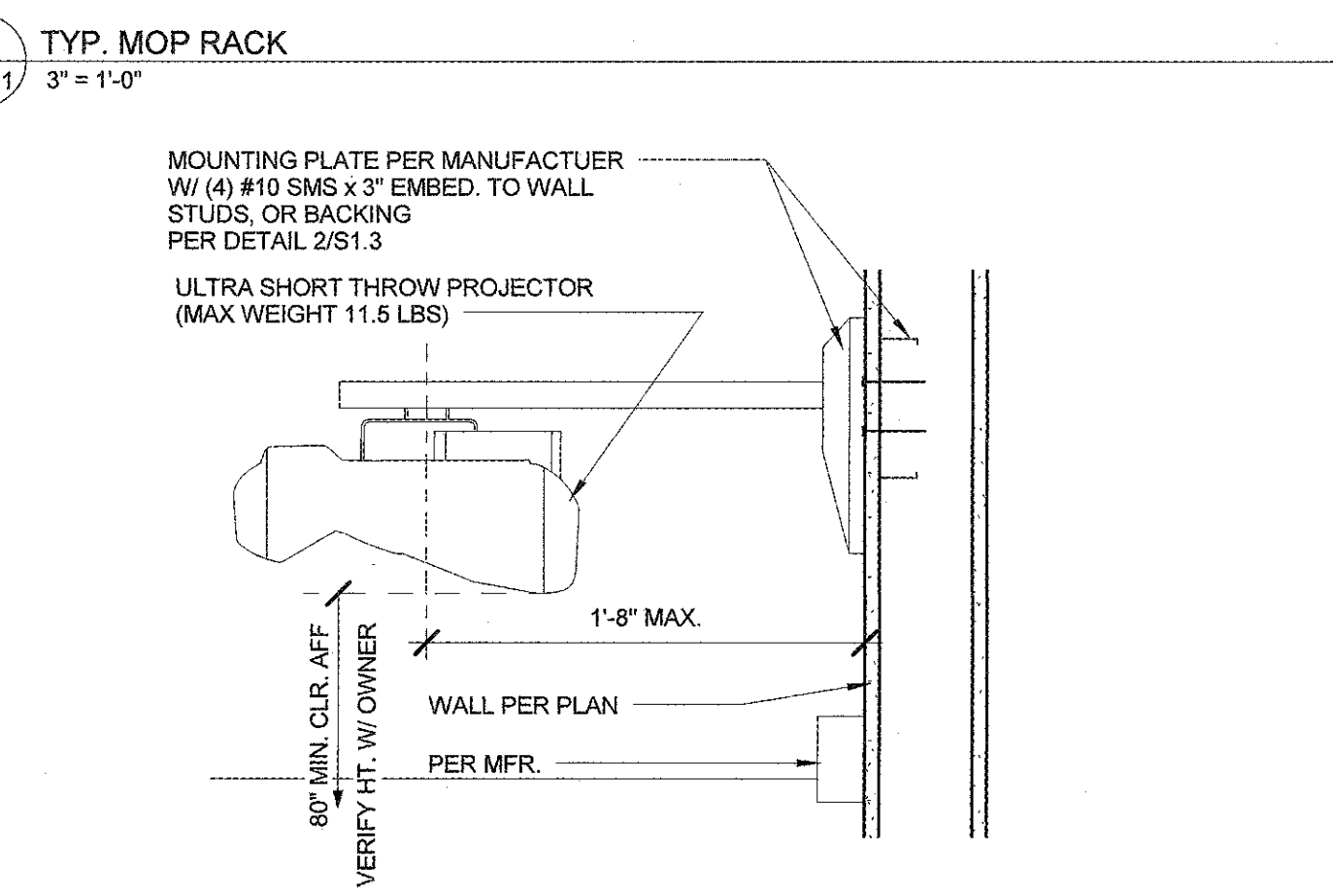
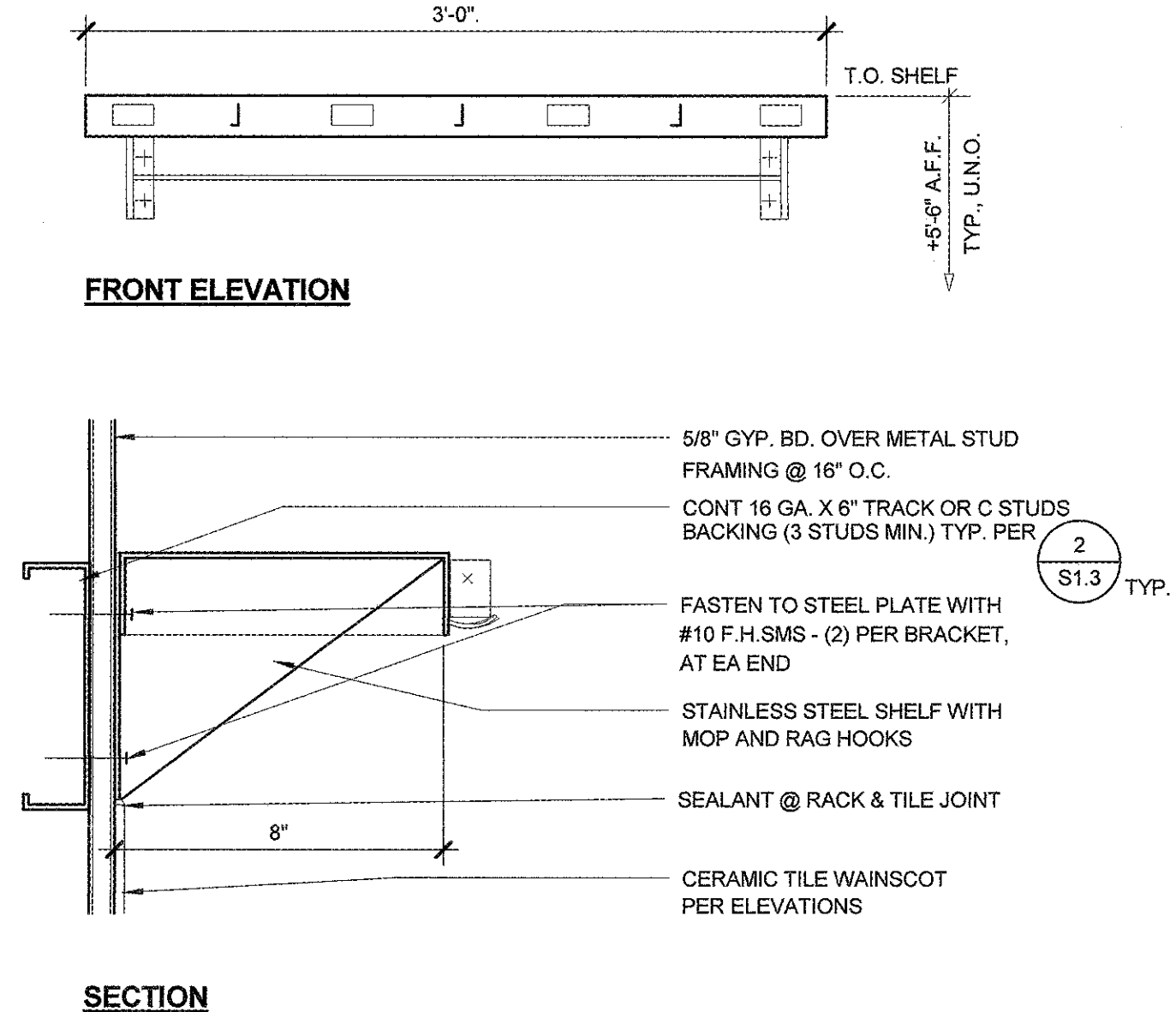
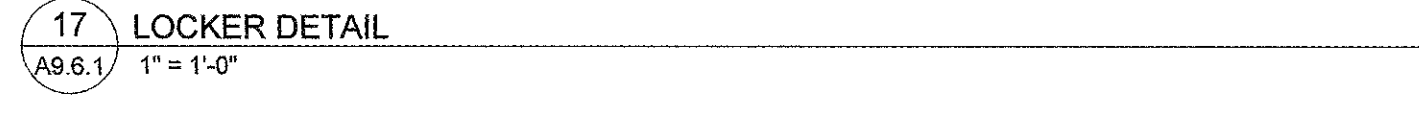
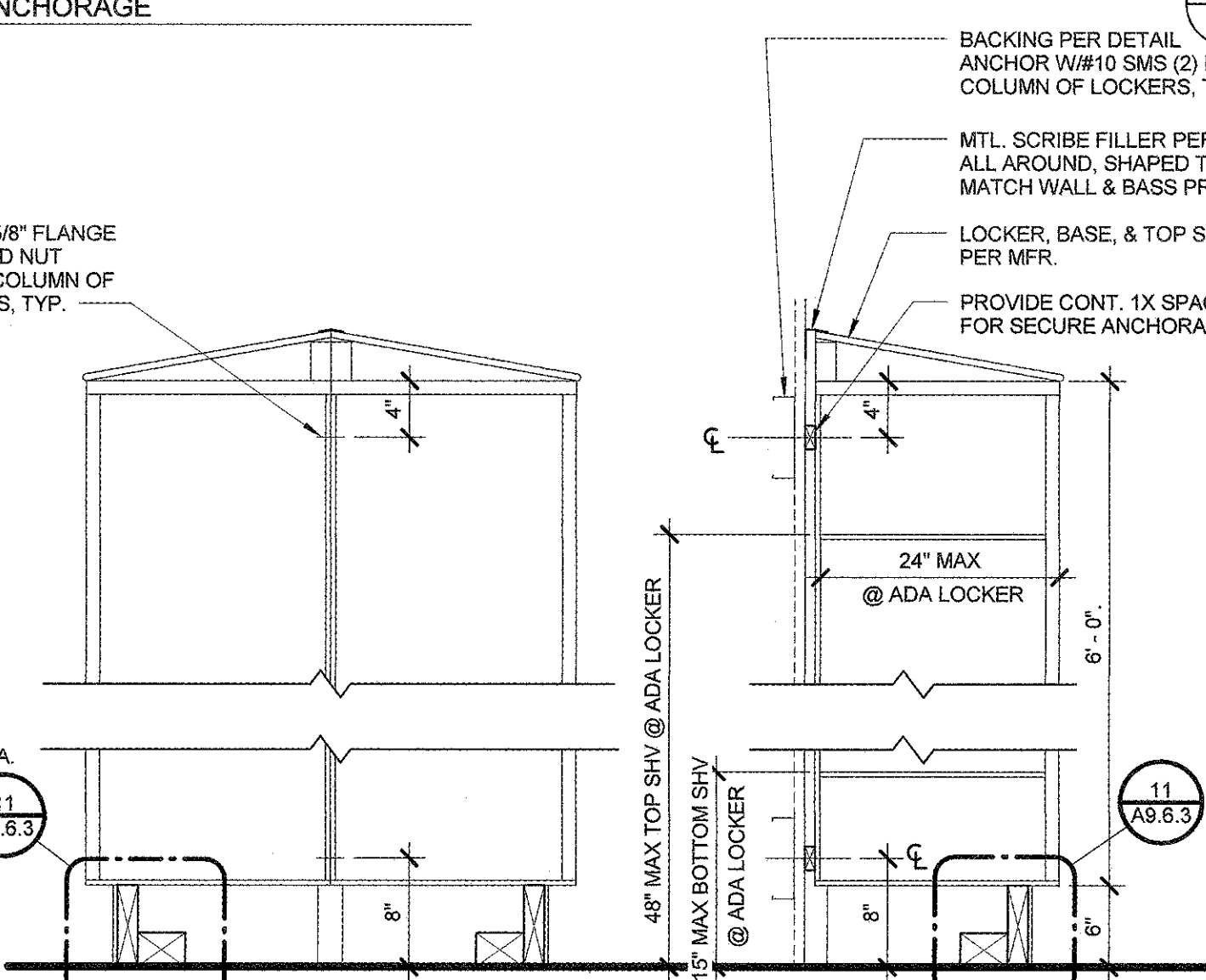
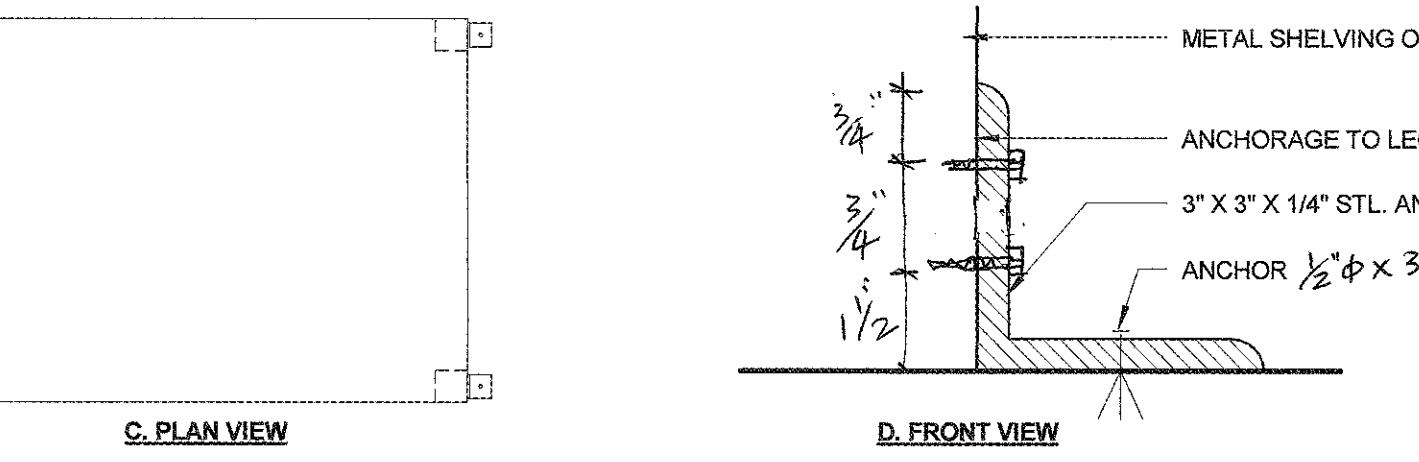
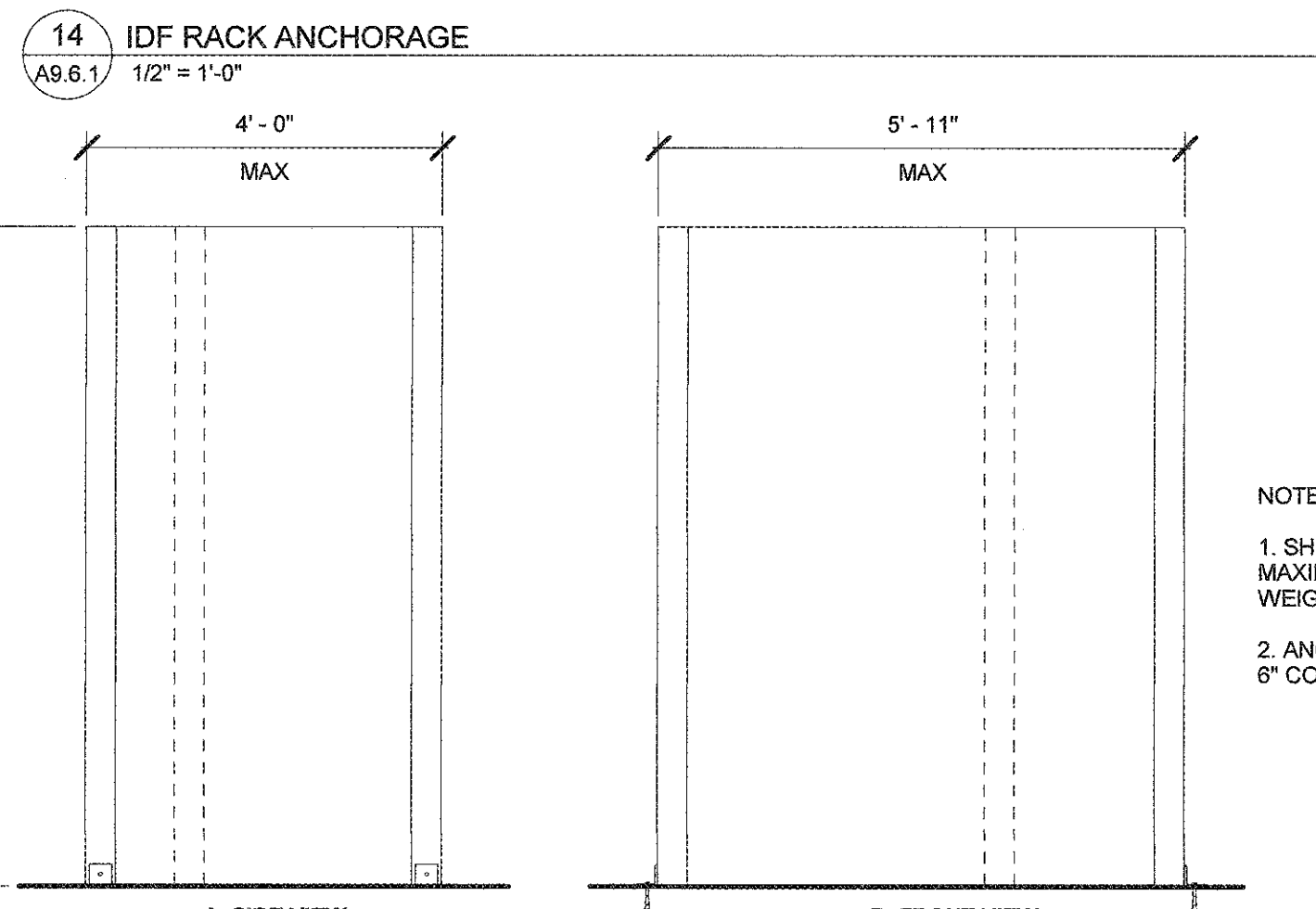
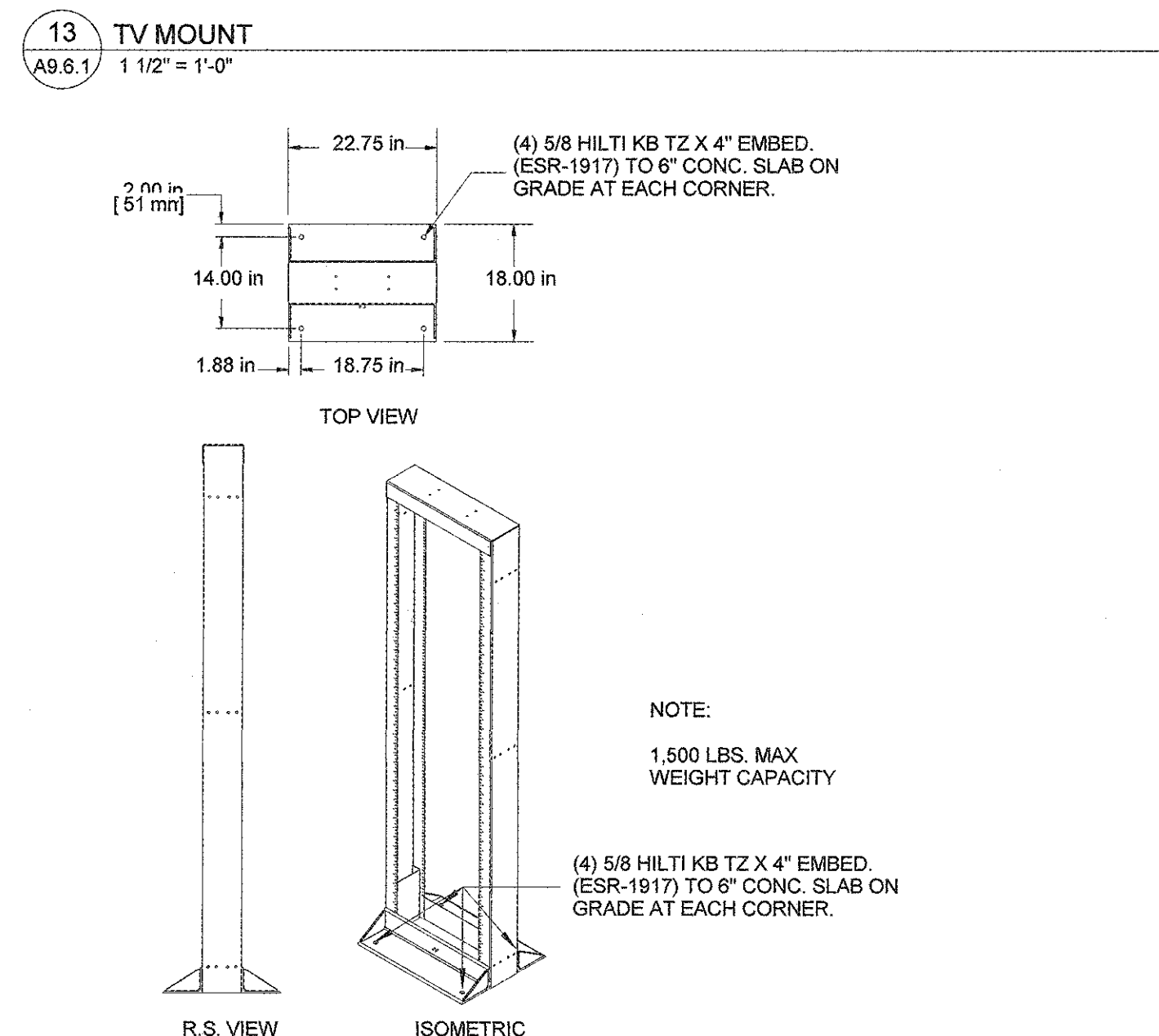
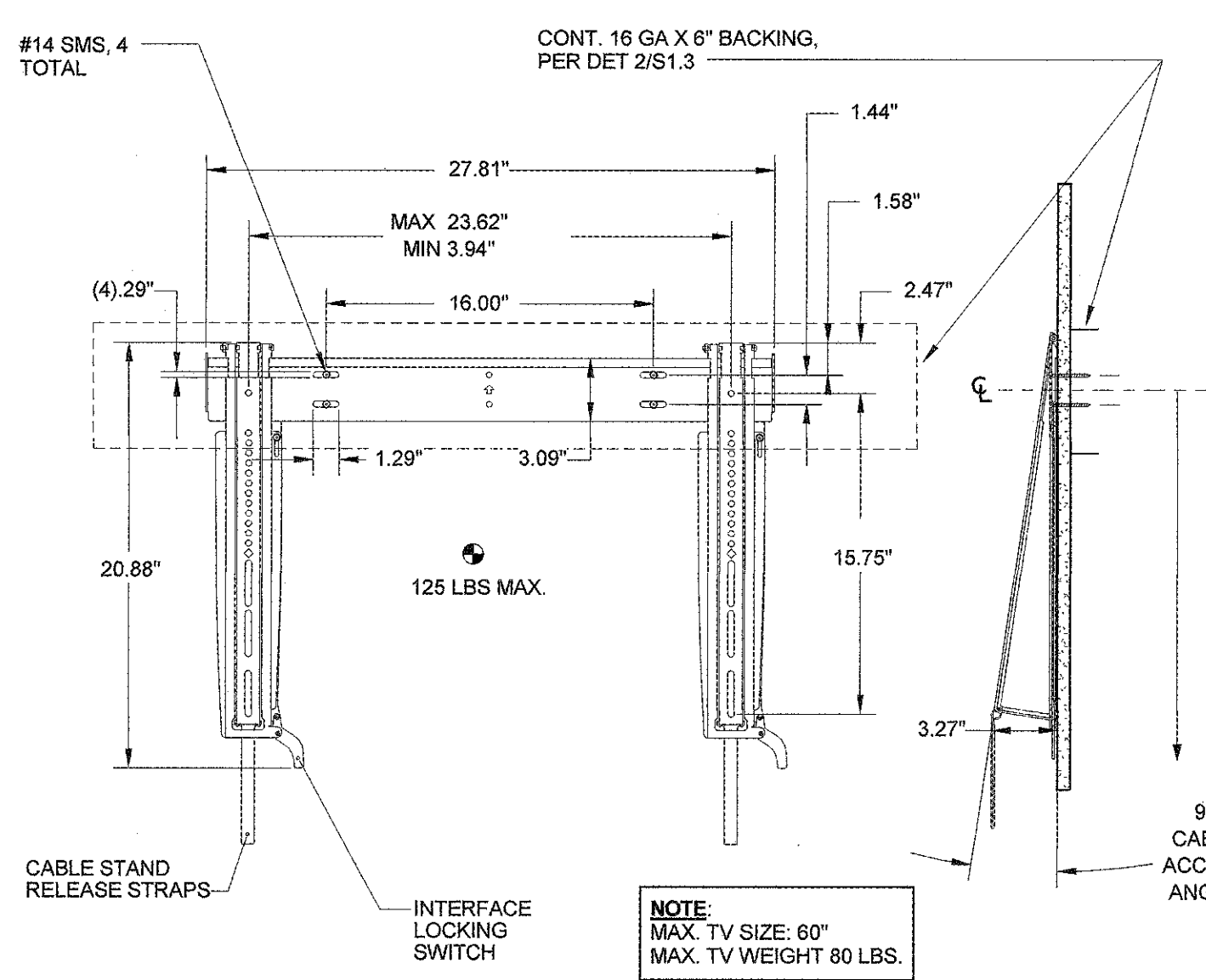

NOTES:

(a) FOR SUGGESTED MOUNTING HEIGHTS OF ACCESSIBLE LAVATORY, SEE 2013 CBC FIG. 11B-10 TOE CLEARANCE SHALL BE THE SAME WIDTH AND SHALL BE A MIN. OF 9 INCHES HIGH FROM THE FLOOR AND MIN. OF 17 INCHES DEEP FROM THE FRONT OF THE LAVATORY.

(b) HOT WATER AND DRAIN PIPES UNDER ACCESSIBLE LAVATORIES SHALL BE INSULATED OR OTHERWISE COVERED. THERE SHALL BE NO SHARP OR ABRASIVE SURFACES UNDER LAVATORIES.

(c) FAUCET CONTROLS AND OPERATING MECHANISM SHALL BE OPERABLE WITH ONE HAND AND SHALL NOT REQUIRE TIGHTGRASPING, PINCHING OR TWISTING OF THE WRIST.

THE FORCE REQUIRED TO ACTIVATE CONTROLS SHALL BE NO GREATER THAN 5 LBS. LEVER-OPERATED, PUSH-TYPE AND ELECTRONICALLY CONTROLLED MECHANISMS ARE EXAMPLES OF ACCEPTABLE DESIGNS. SELF-CLOSING VALVES ARE ALLOWED IF THE FAUCET REMAINS OPEN FOR AT LEAST 10 SECONDS.

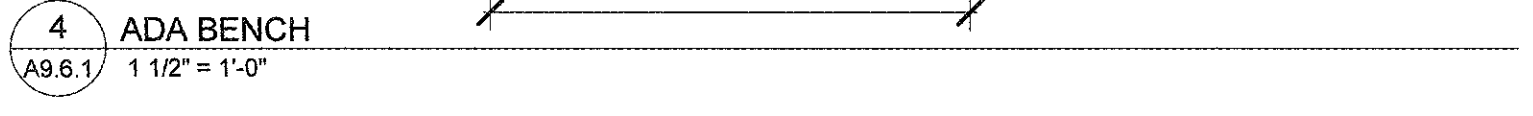
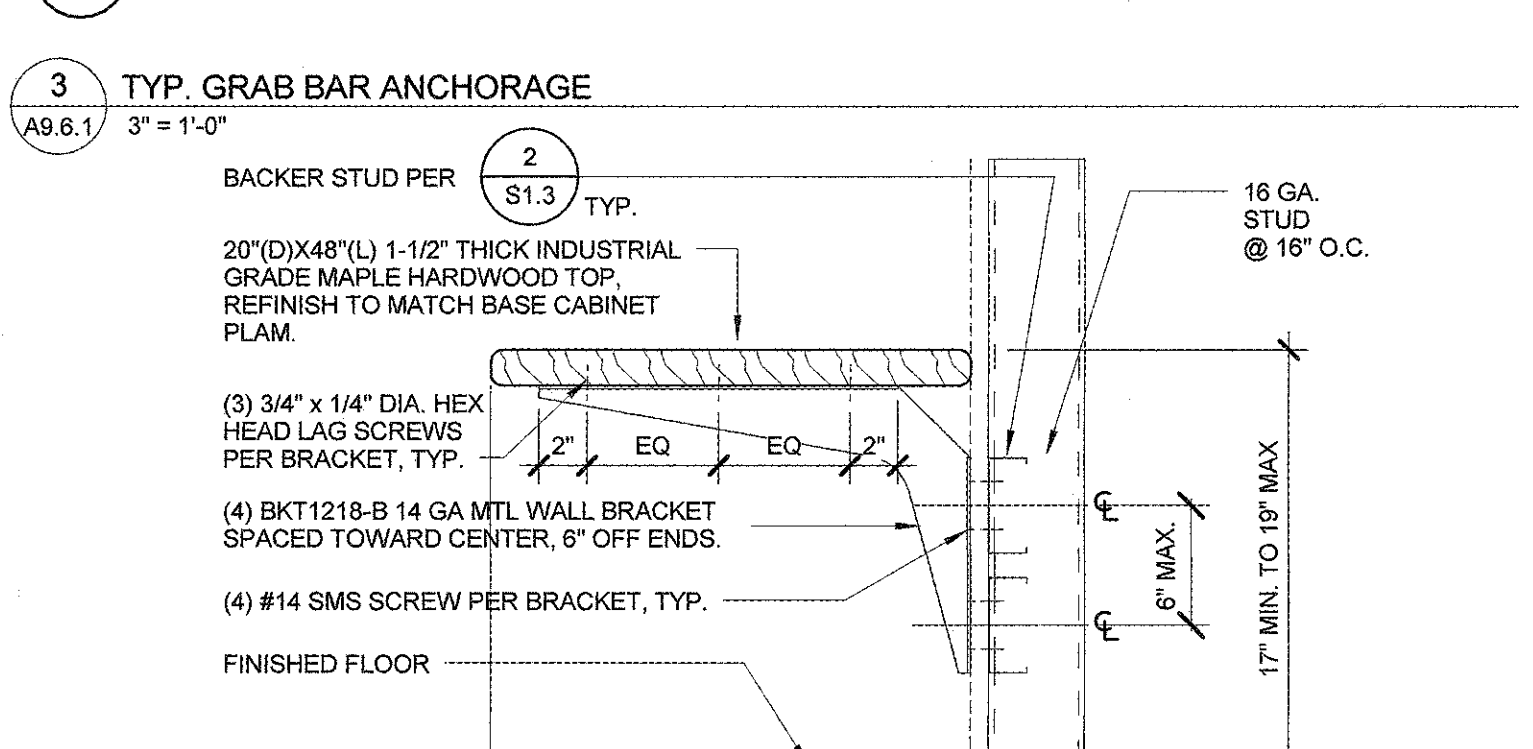
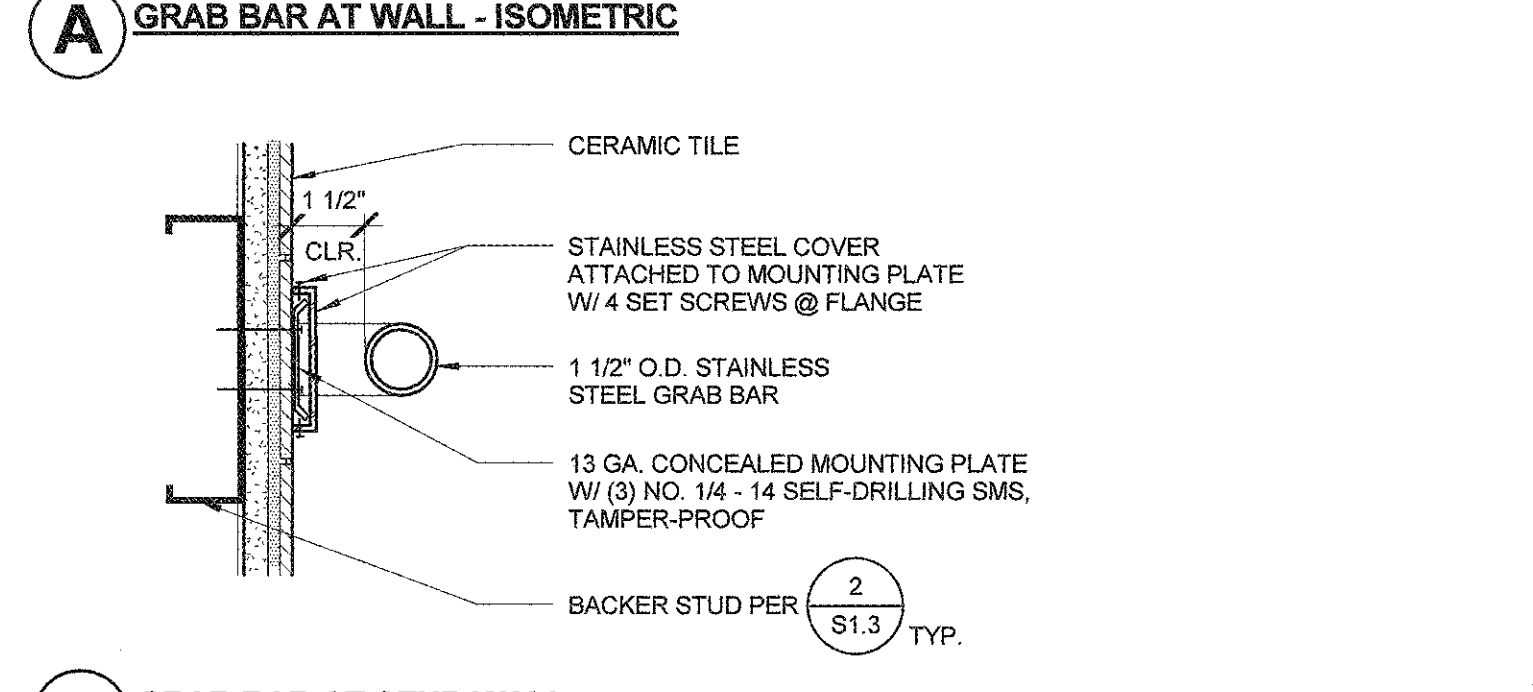
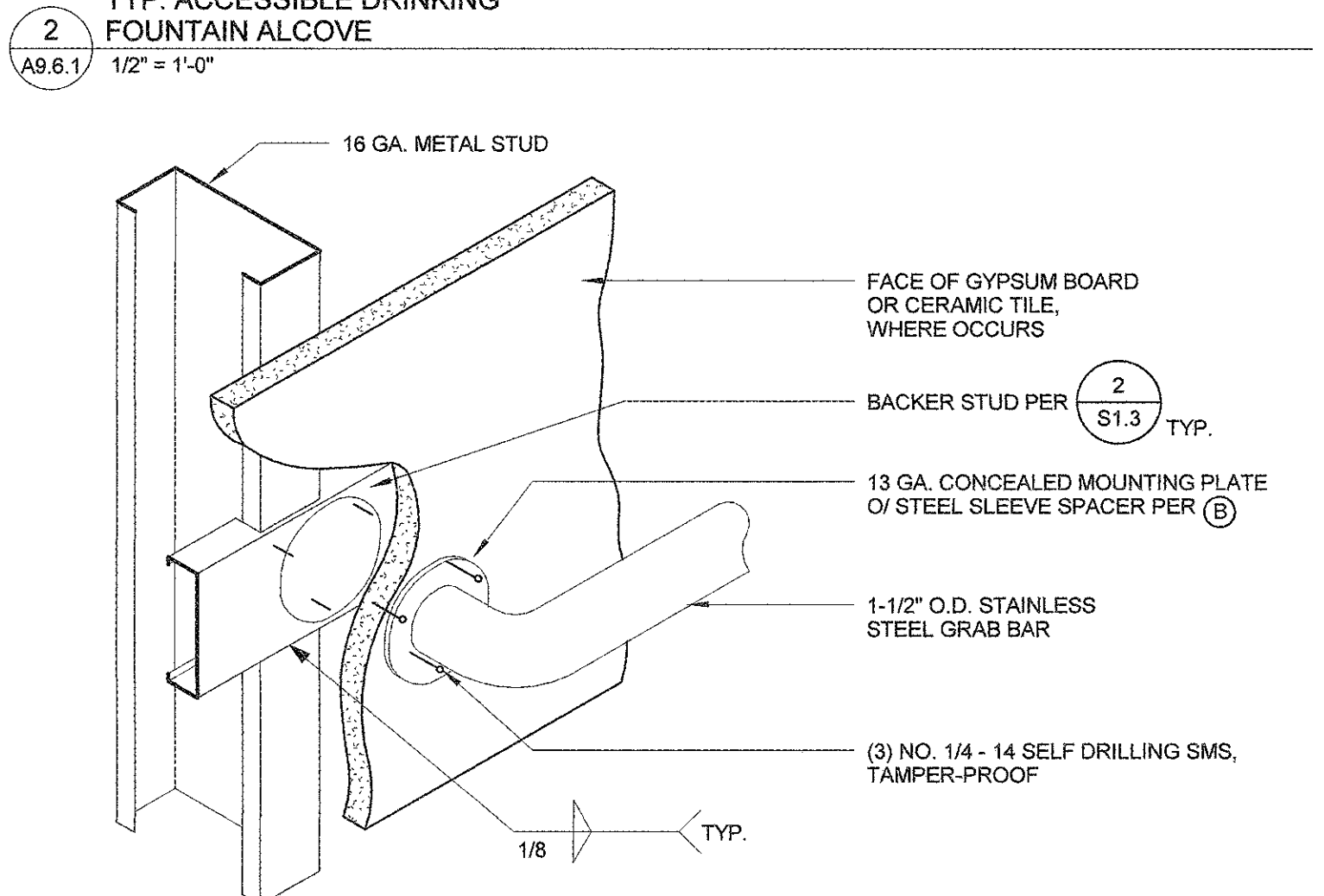
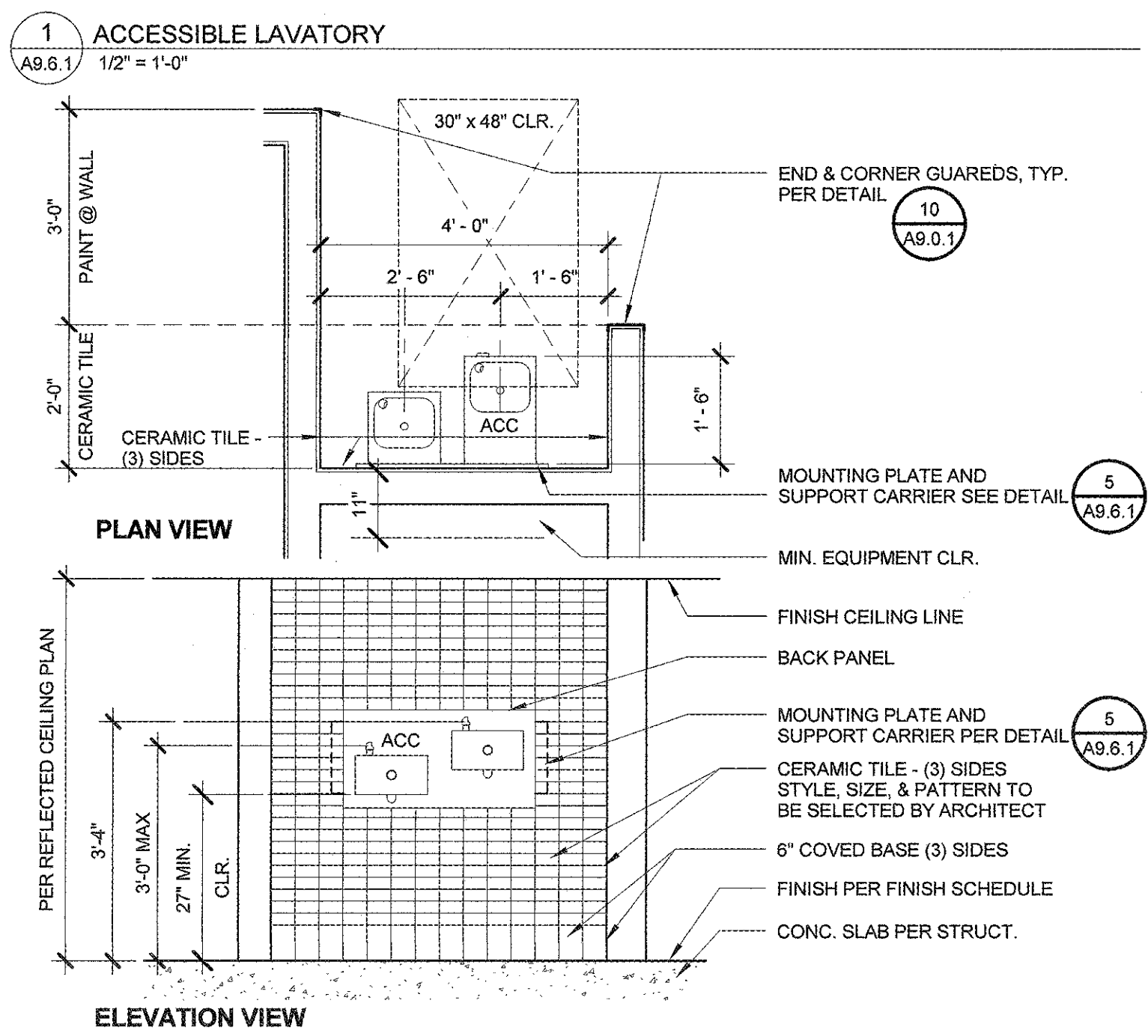

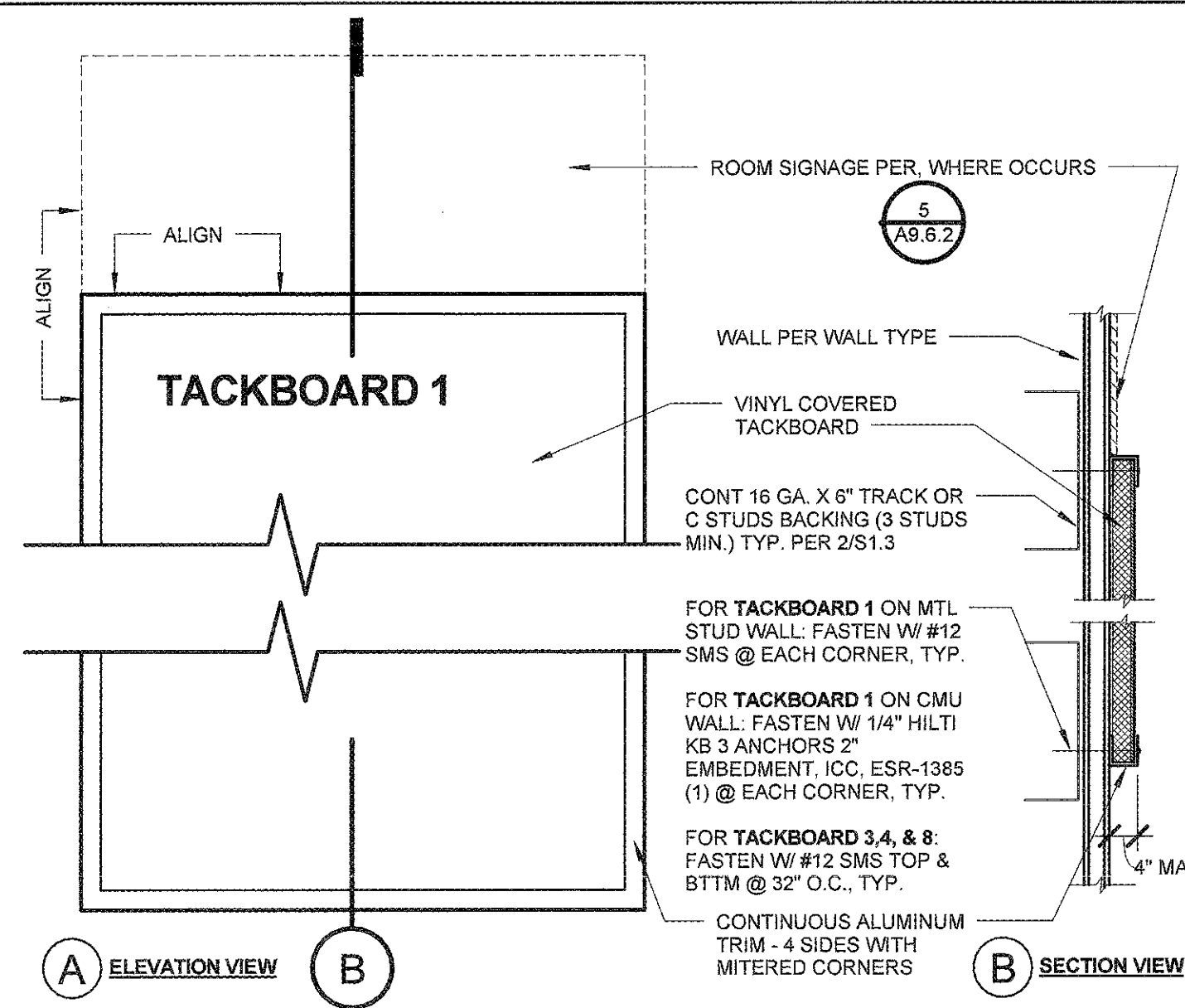

10 TYPICAL TACKBOARD AND SIGNAGE ATTACHMENT
3" = 1'-0"

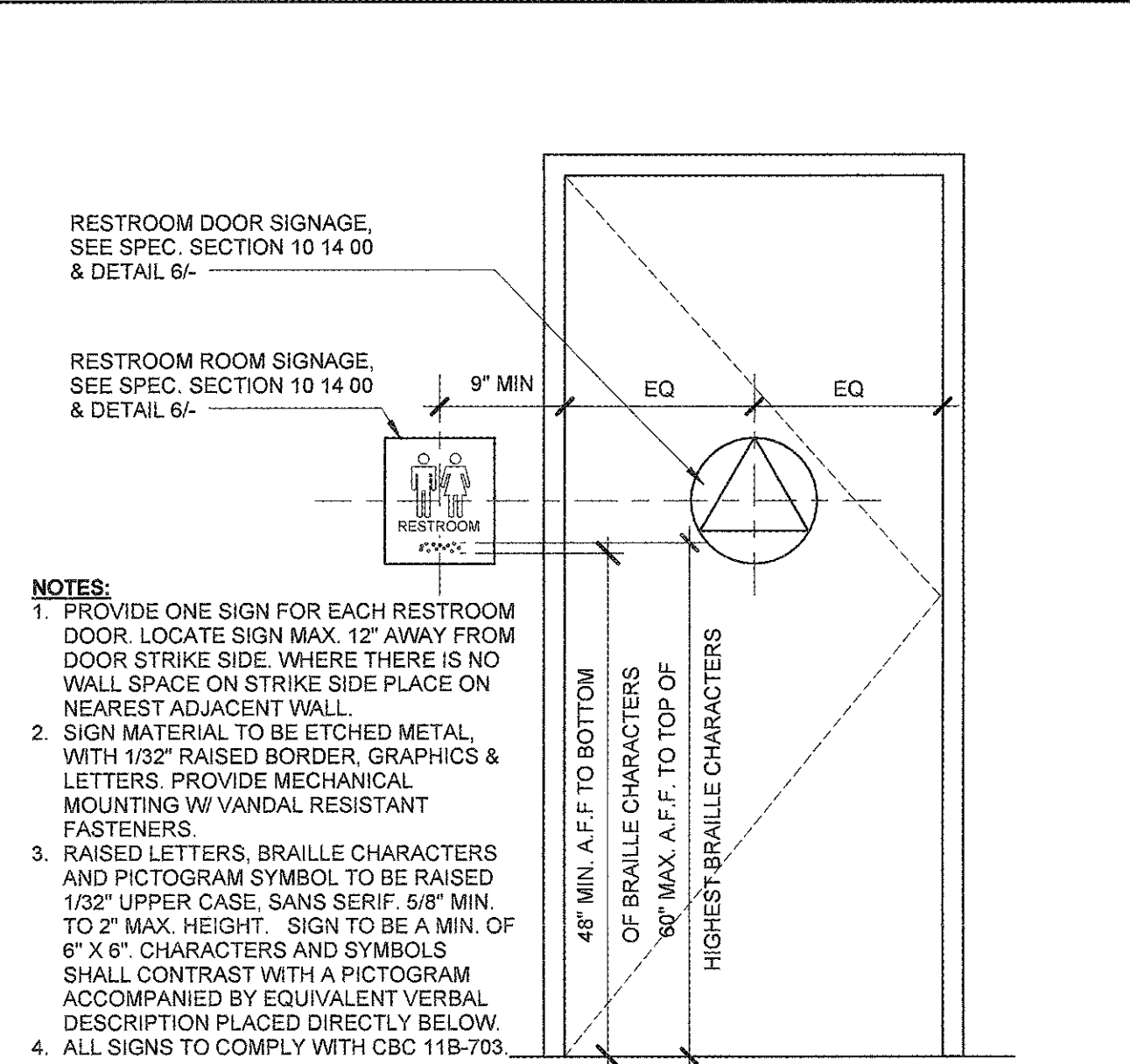

7 TYPICAL ROOM SIGN DETAIL/ELEVATION
3/4" = 1'-0"

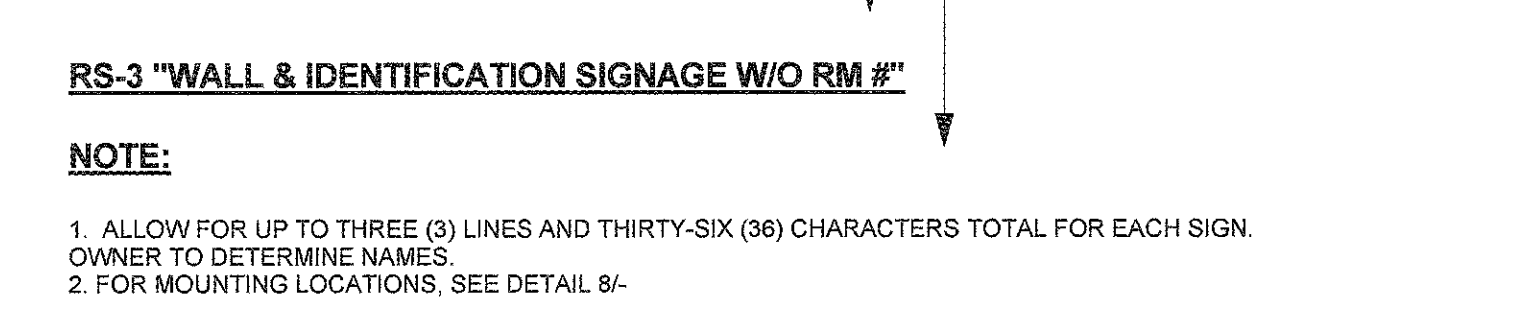
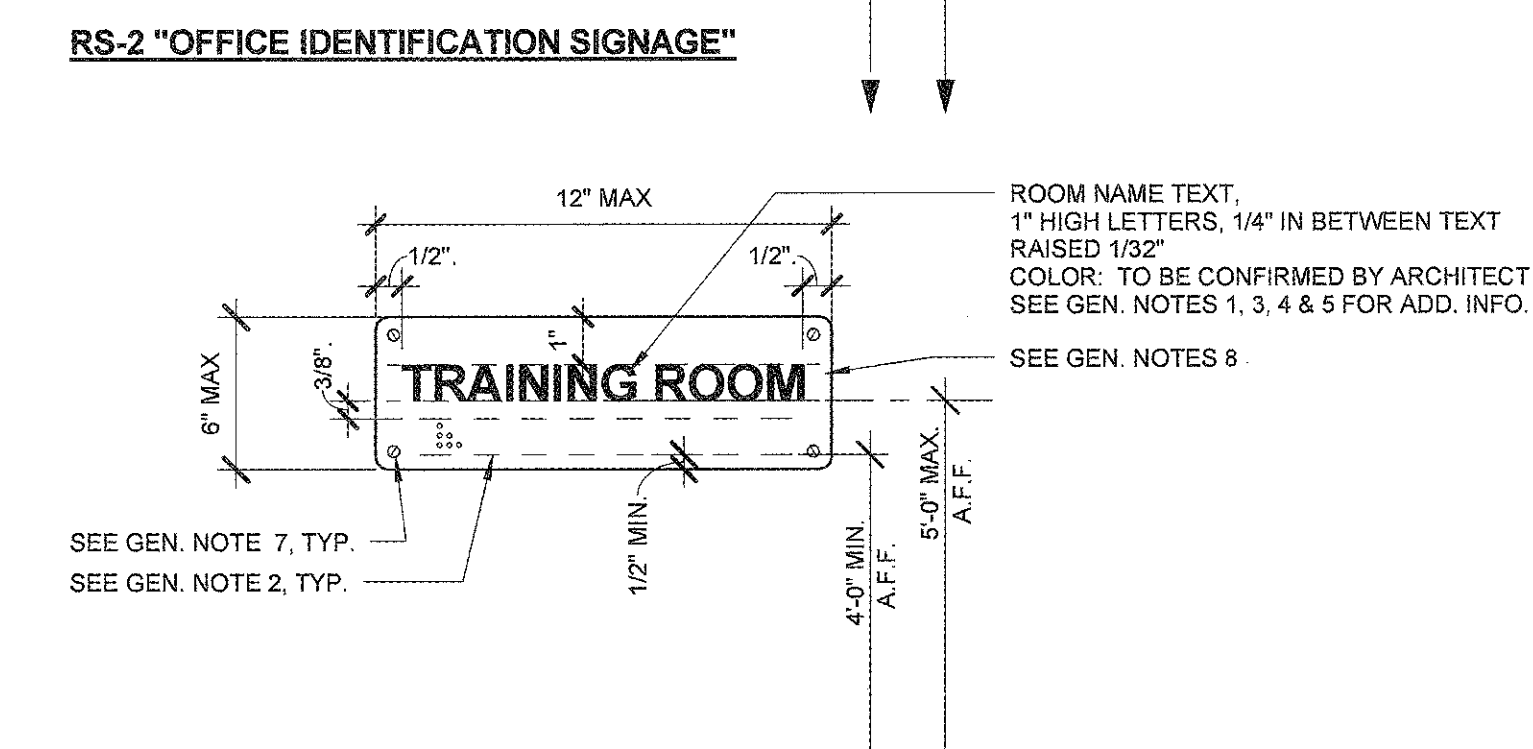
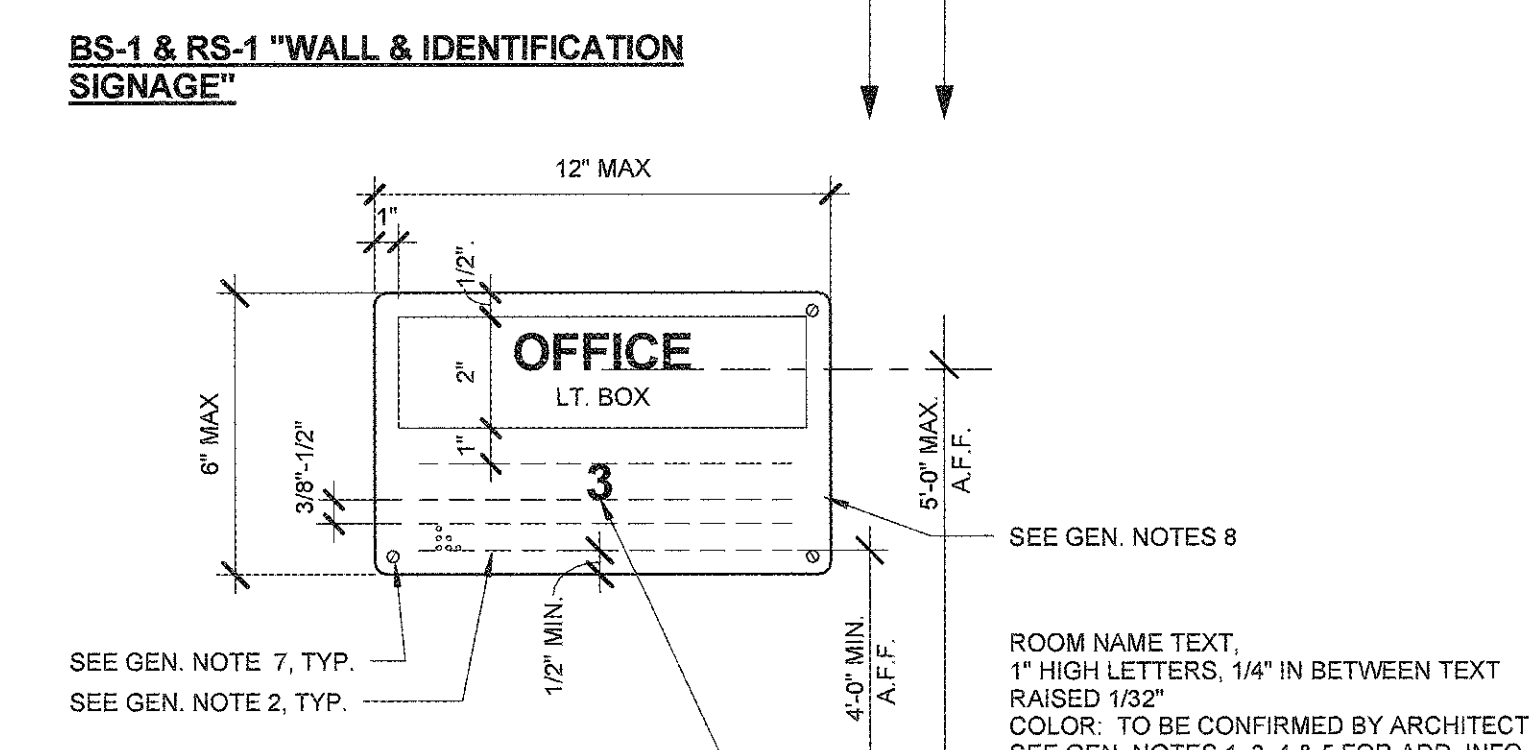
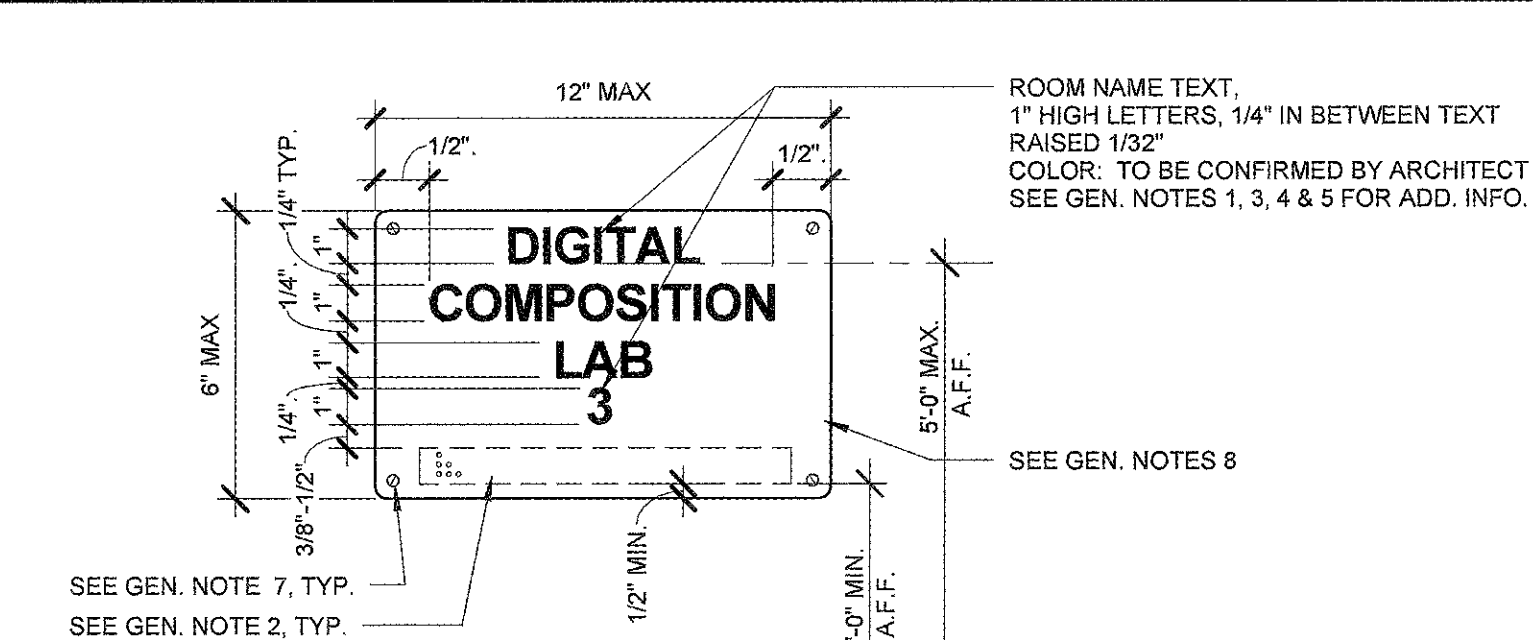

5 TYP. INTERIOR DOOR & ROOM SIGNAGE
3" = 1'-0"

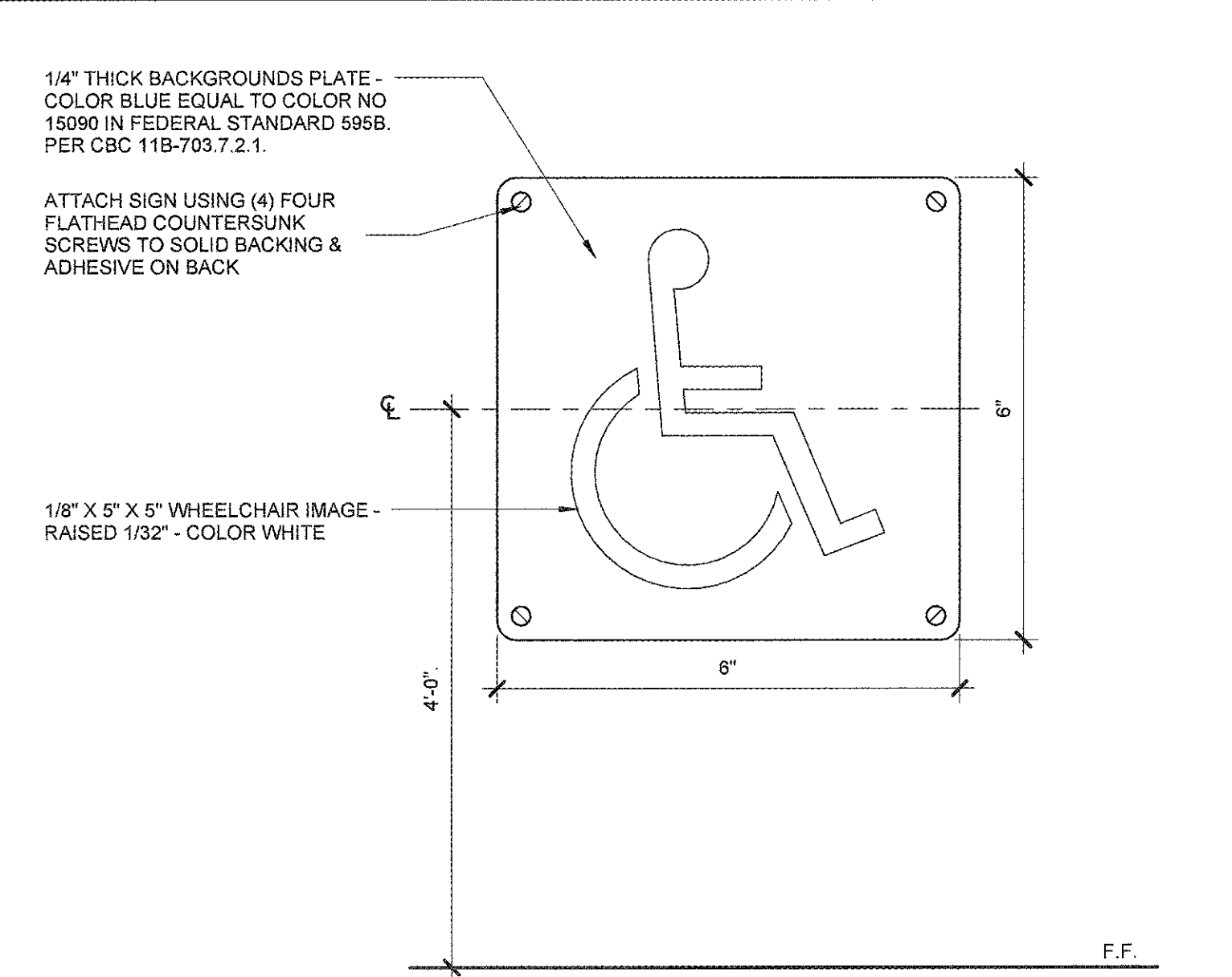

1 ISA
6" = 1'-0"

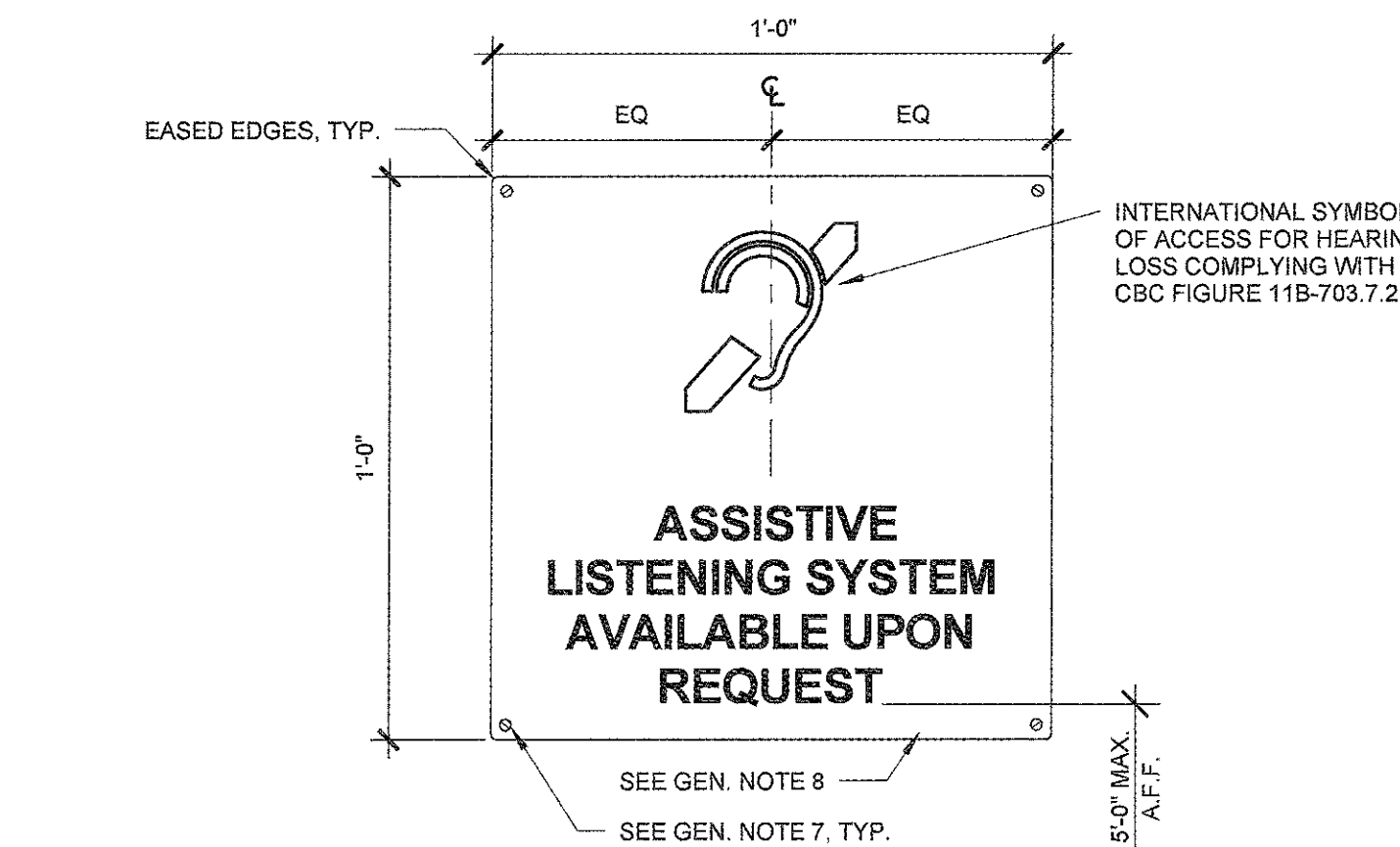

11 TYP. OCCUPANCY POSTING SIGNAGE AT ASSEMBLIES
3" = 1'-0"

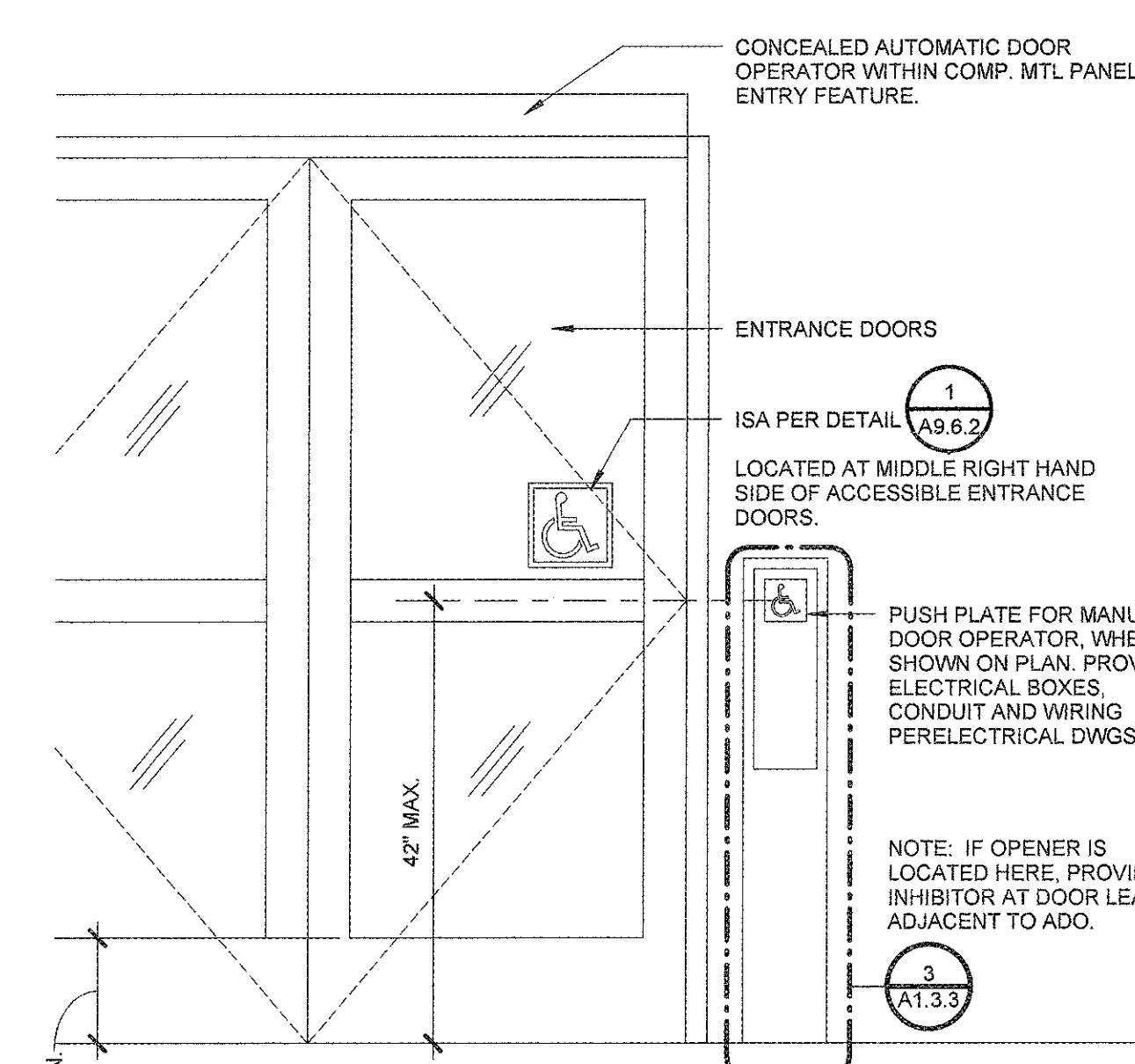

8 TYP. ENTRANCE DOOR
3" = 1'-0"

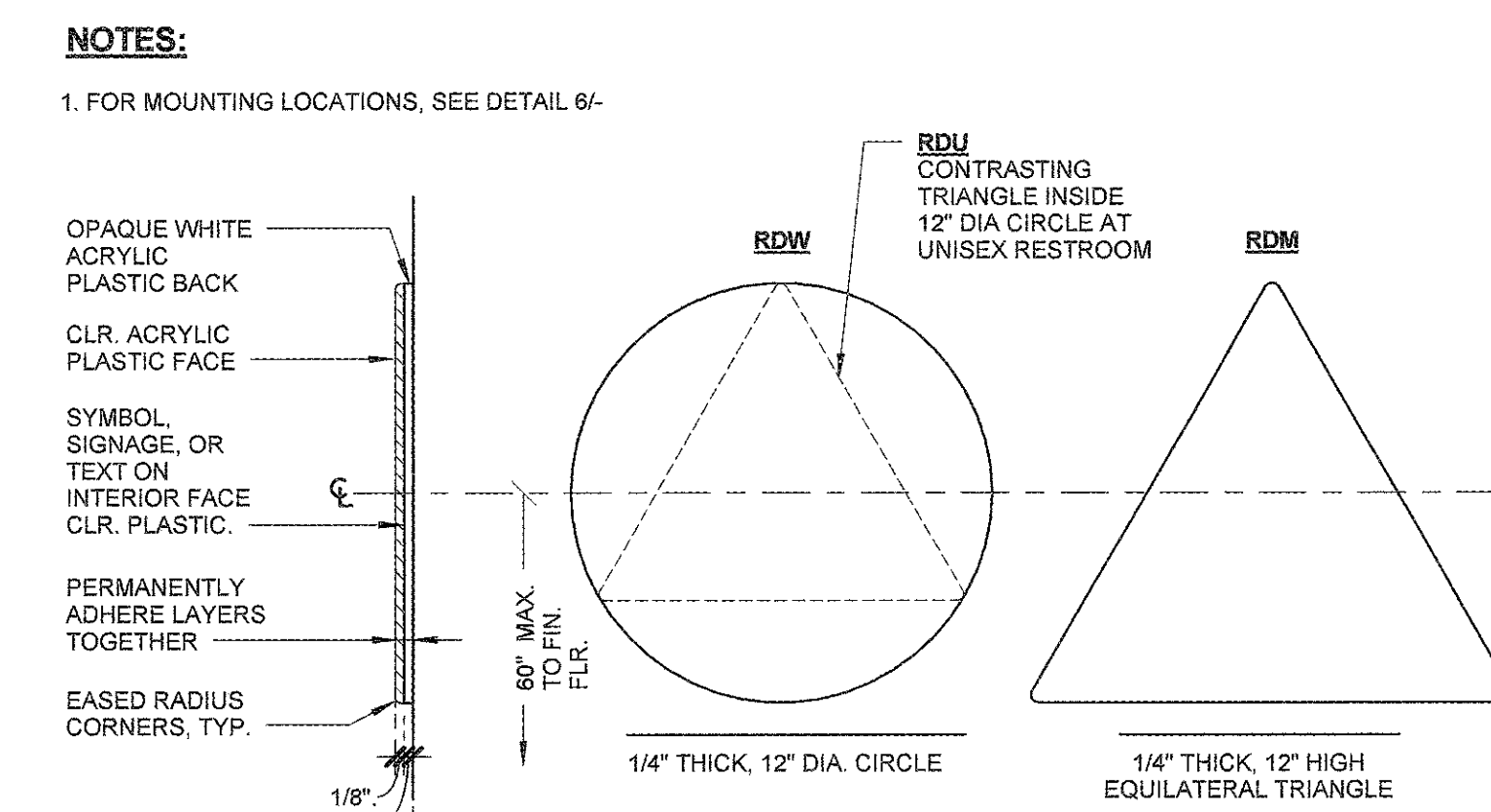

6 ACCESSIBLE TOILET ROOM GEOMETRIC DOOR SYMBOLS
3" = 1'-0"

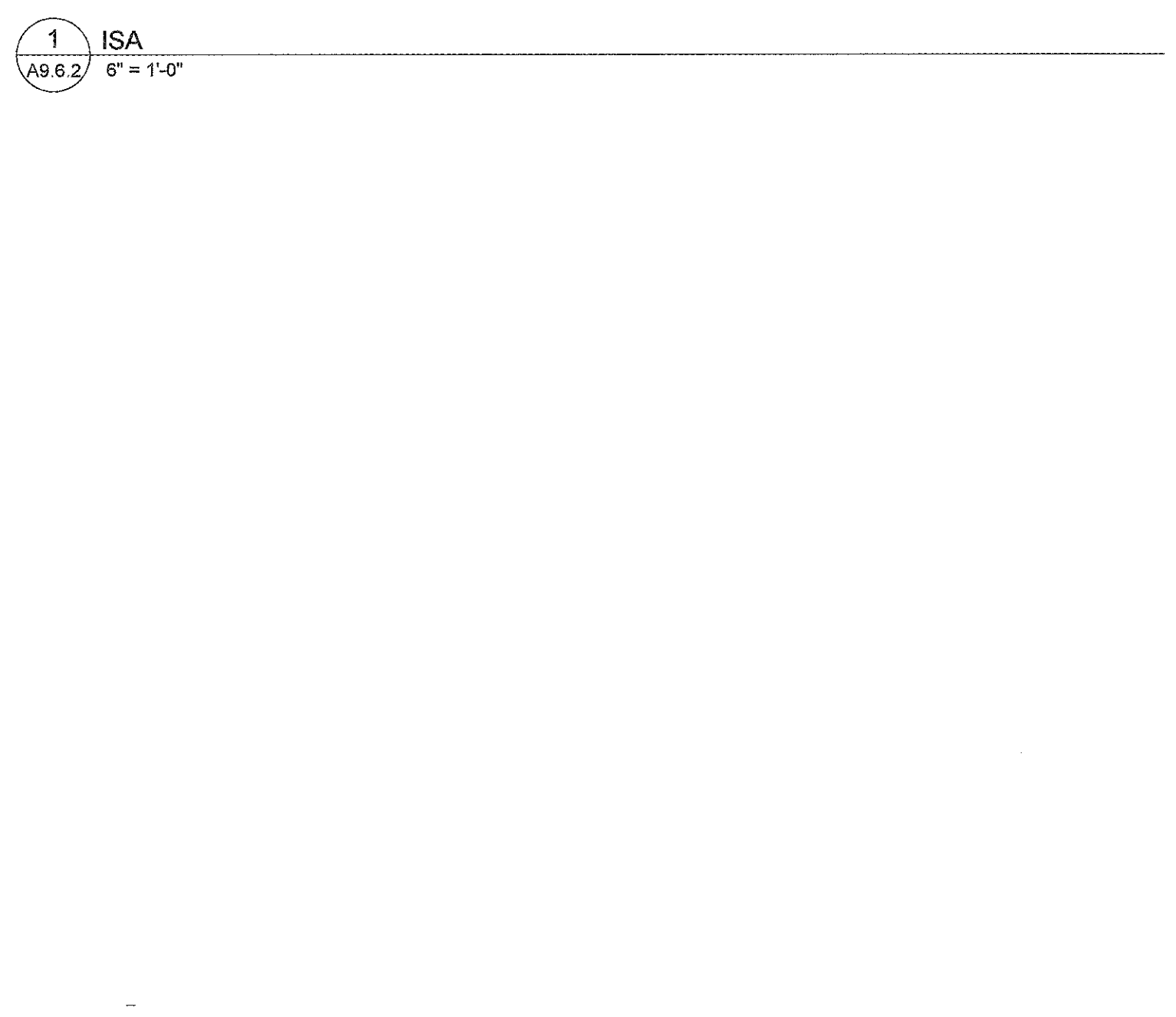

2 CHARACTER PROPORTIONS & BRAILLE SPACING TEMPLATES
12" = 1'-0"

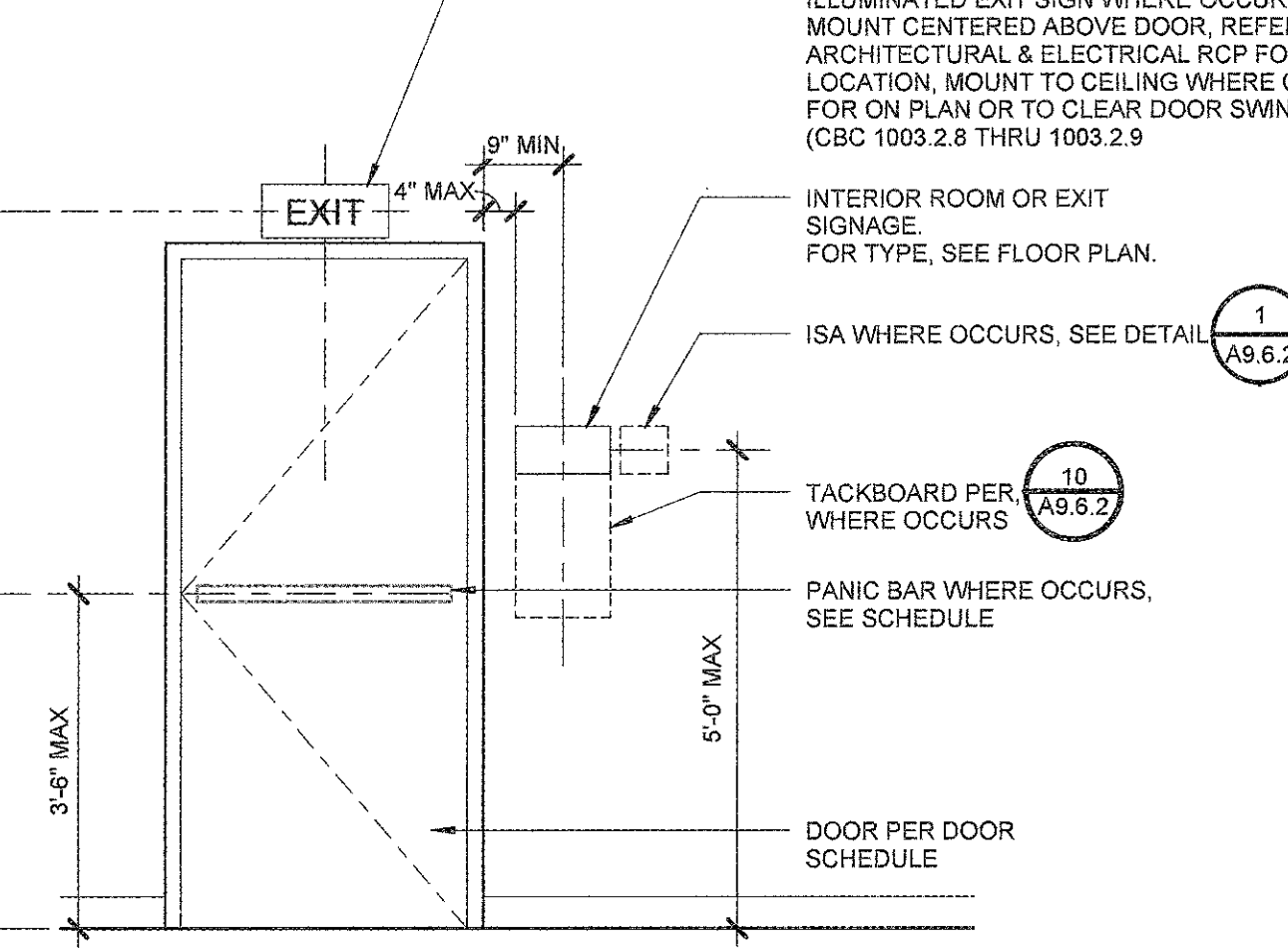

9 AT TYP. DOORS
3" = 1'-0"

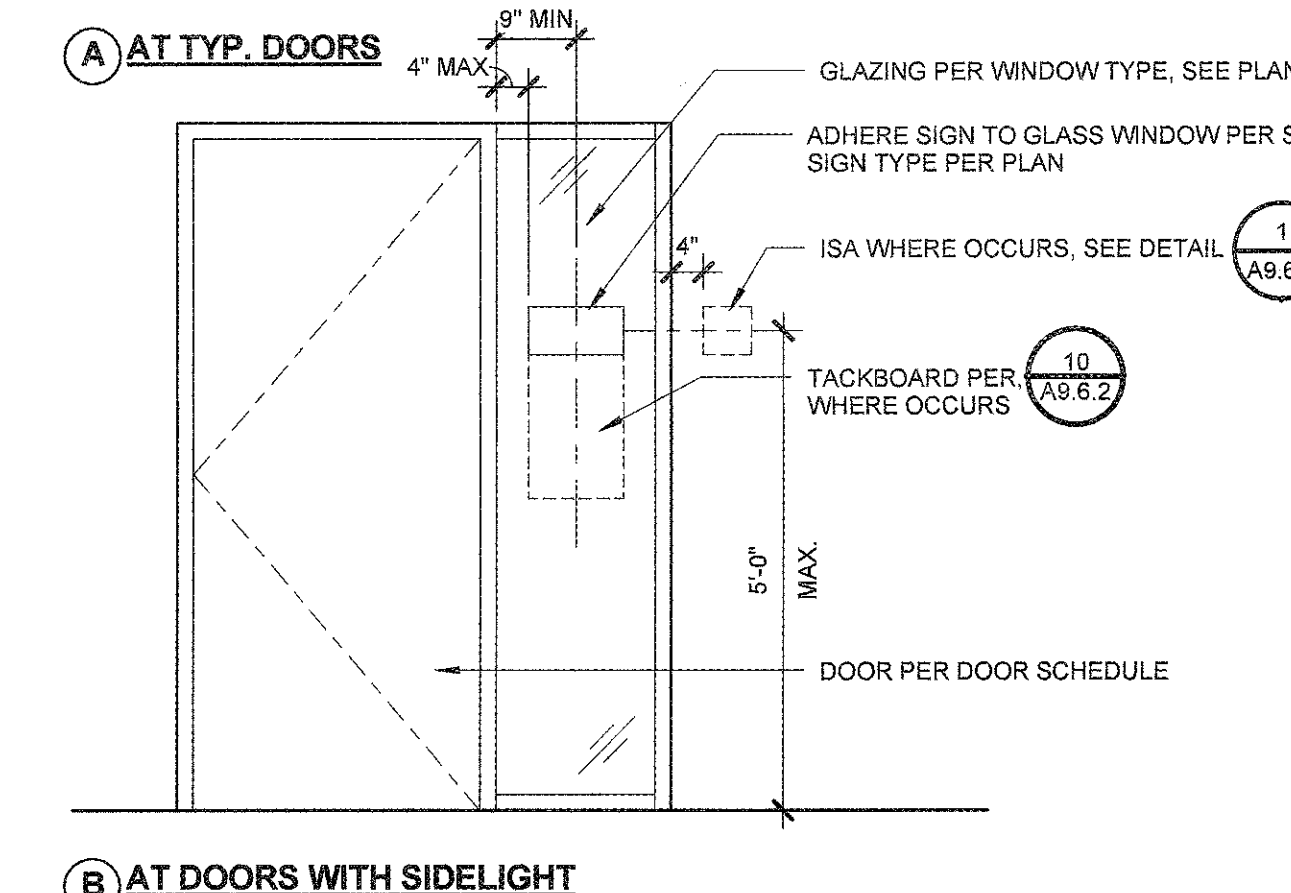

9 AT DOORS WITH SIDELIGHT
3" = 1'-0"

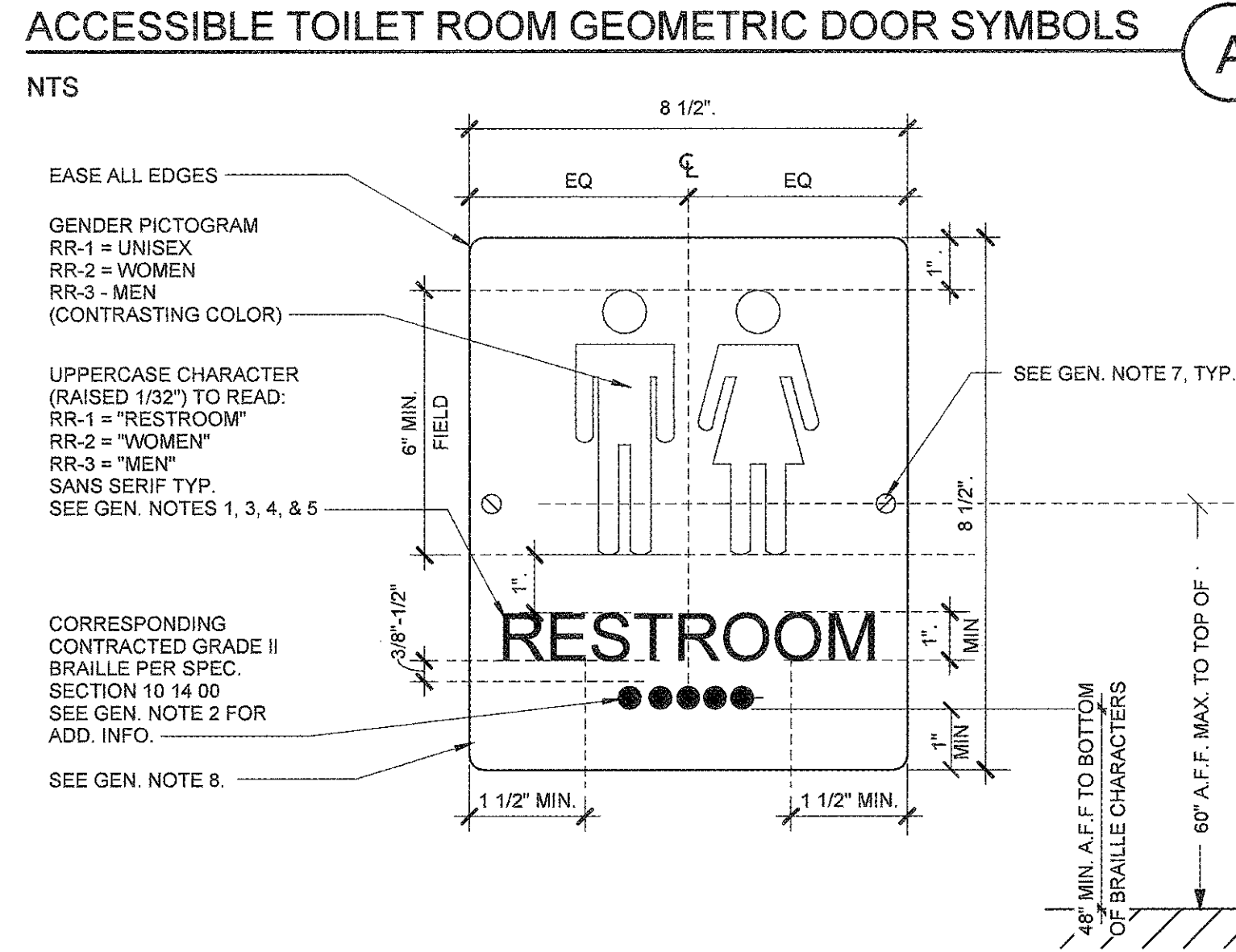

6 TOILET ROOM SIGN
3" = 1'-0"

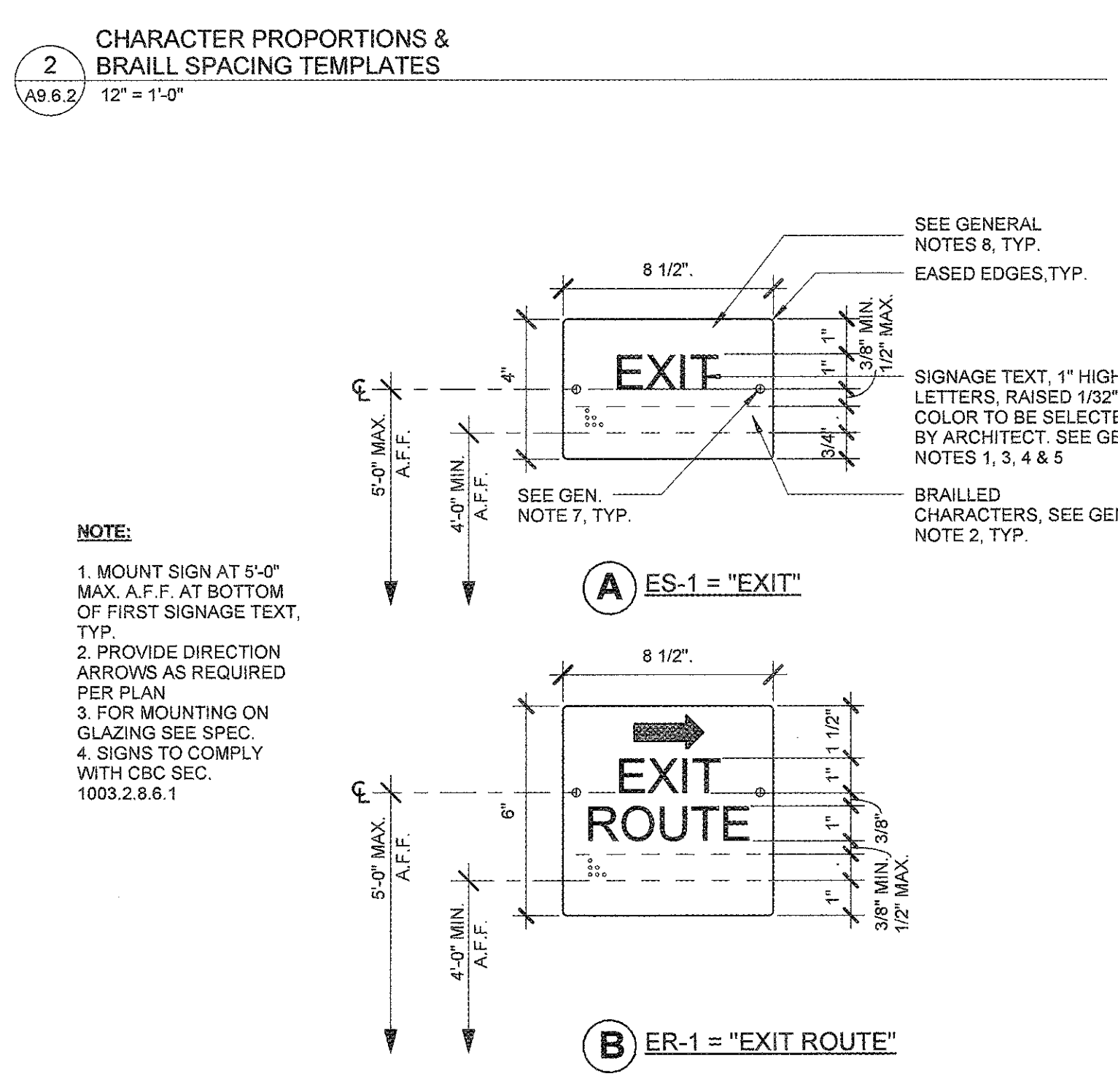

3 TACTILE EXIT SIGNAGE
3" = 1'-0"

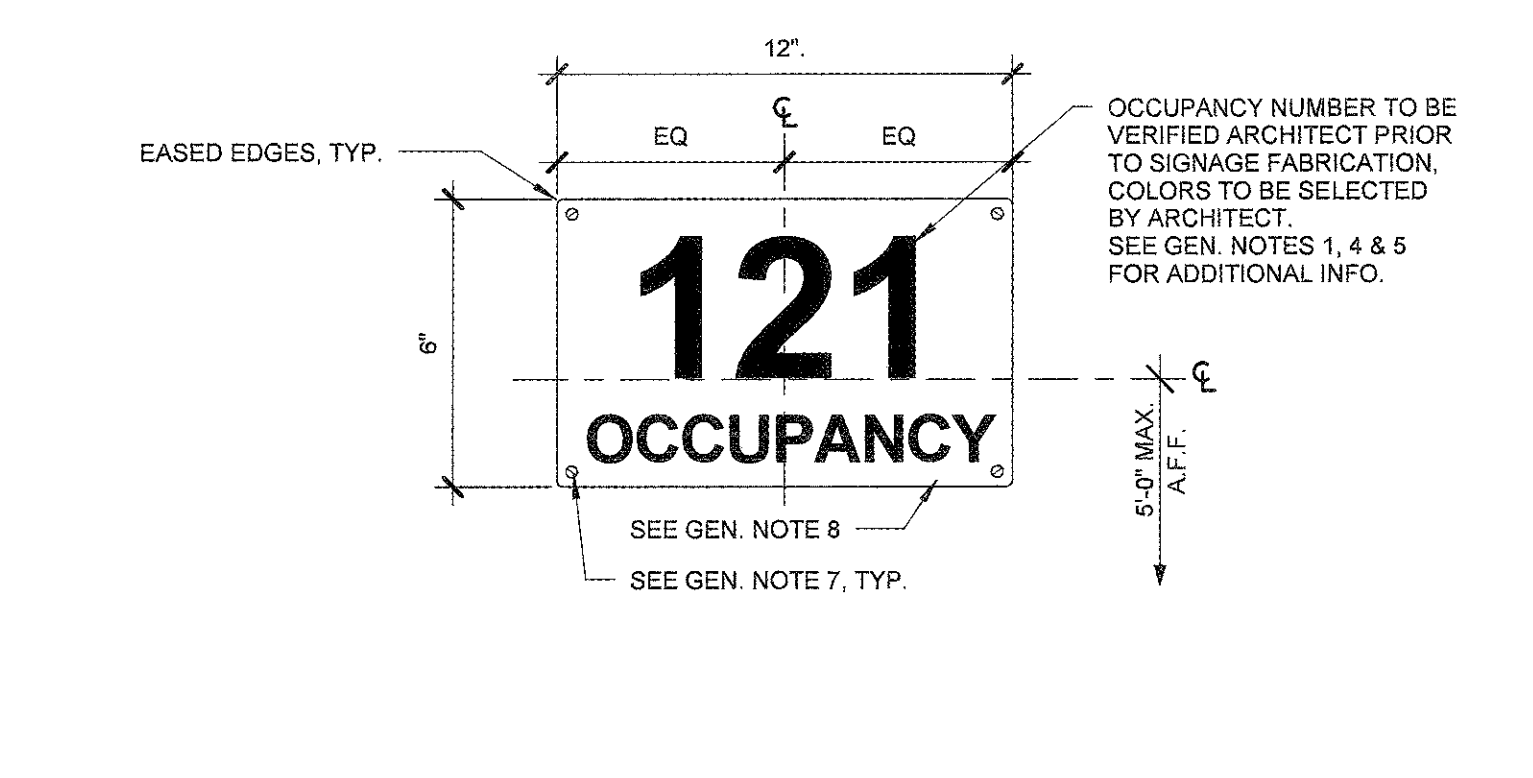

4 TYP. OCCUPANCY POSTING SIGNAGE AT ASSEMBLIES
3" = 1'-0"

LITTLE
DIVERSIFIED ARCHITECTURAL CONSULTING

1300 Dove Street, Suite 100
Newport Beach, CA 92660
T: 949.698.1400 F: 949.698.1433
www.littleonline.com

This drawing and the design shown are the property of Little Diversified Architectural Consulting. The reproduction, copying or other use of this drawing without their written consent is prohibited and any infringement will be subject to legal action.

© Little 2016

COMPTON CCD

CAMPUS PUBLIC SAFETY BUILDING

1111 EAST ARTESIA BOULEVARD,
COMPTON CALIFORNIA 90221

GENERAL NOTES:
1. CHARACTER TYPE: CHARACTERS ON SIGNS SHALL BE RAISED 1/32" (0.794 mm) MINIMUM AND SHALL BE SANS SERIF UPPER CASE CHARACTERS ACCOMPANIED BY CONTRACTED GRADE 2 BRAILLE. (SEE NOTE 2 BELOW)
2. BRAILLE: SHALL BE CONTRACTED (GRADE 2) AND SHALL COMPLY WITH SECTIONS 11B-703.3 AND 11B-703.4. SEE DETAIL 4-1.
3. CHARACTER SIZE: RAISED CHARACTERS SHALL BE A MINIMUM OF 5/8" (15.9 mm) AND A MAXIMUM OF 2" (51 mm) IN HEIGHT. 11B-703.2.5.
4. FINISH & CONTRAST: CONTRAST BETWEEN CHARACTERS, SYMBOLS, AND THEIR BACKGROUND MUST BE 70% MINIMUM AND HAVE A NON-Glare FINISH. 11B-703.5.1.
5. PROPORTIONS: CHARACTERS ON SIGNS SHALL HAVE A WIDTH-TO-HEIGHT RATIO OF BETWEEN 1:5 AND 1:10 11B-703.2.4.
6. ATTACH SIGN USING FLATHEAD COUNTERSUNK SCREWS, QUANTITY AND LOCATIONS SHOWN IN DETAILS, TO SOLID BACKING & ADHESIVE TO BACK.
7. FOR INTERIOR SIGNAGE USE PLATE OF 1/8" THICK PHOTO SENSITIVE ACRYLIC ETCHED TO FORM A SINGLE PLAQUE SIGN WILL BE A (2) TWO COLOR SIGN WITH A LIGHT BACKGROUND & DARK CHARACTERS. COLORS TO BE DETERMINED BY ARCHITECT.
8. FOR EXTERIOR SIGNAGE USE PLATE OF 1/8" ANODIZED ALUMINUM ETCHED TO FORM A SINGLE PLAQUE SIGN WITH (2) COLORS: LIGHT BACKGROUND & DARK CHARACTERS. COLORS TO BE DETERMINED BY ARCHITECT.
9. ALL ROOM LOCATIONS OF SIGNAGE SHALL BE REVIEWED BY OWNER BEFORE INSTALLATION.

IDENTIFICATION STAMP
DIV. OF THE STATE ARCHITECT
OFFICE OF REGULATION SERVICES

FILE NO: 19-C1
AR: 03-117673

AC: [Signature] PLS: [Signature] SS: [Signature] PO: [Signature]
DATE: DEC 12 2017

PRINCIPAL IN CHARGE
RITA S. CARTER

PROJECT MANAGER
SHOJI TAKESHIMA / DAVID PHAN

DRAWN BY
DAVID PHAN

NO REASON DATE

LICENSED ARCHITECT
NO. C35431
REL. 4-30-19

SIGNAGE DETAILS

PROJECT NUMBER
913-4675-00

DATE
12/01/16

SHEET NO.
A9.6.2

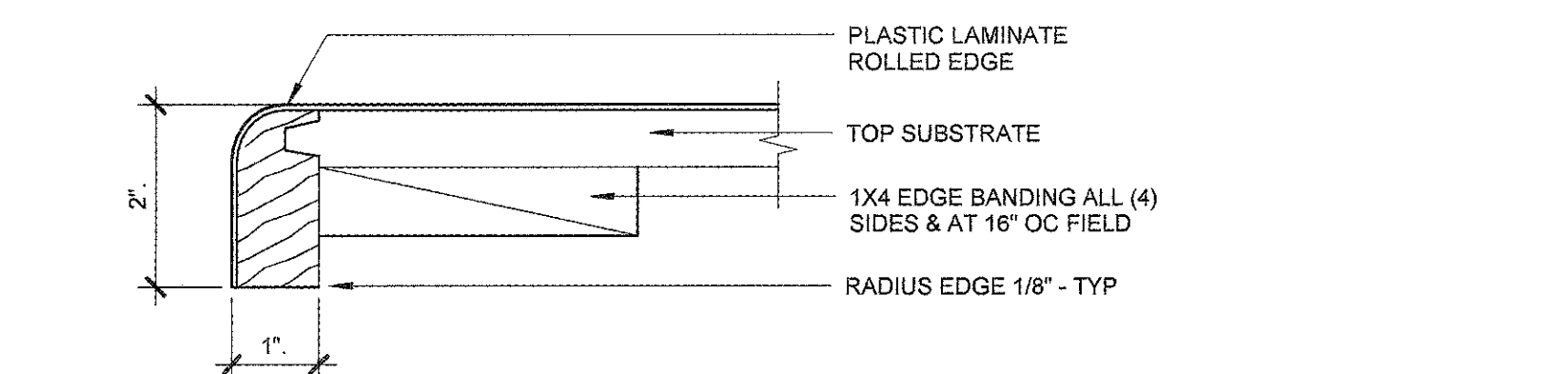

13 TYP. EDGE DETAIL
A9.6.3 6" = 1'-0"

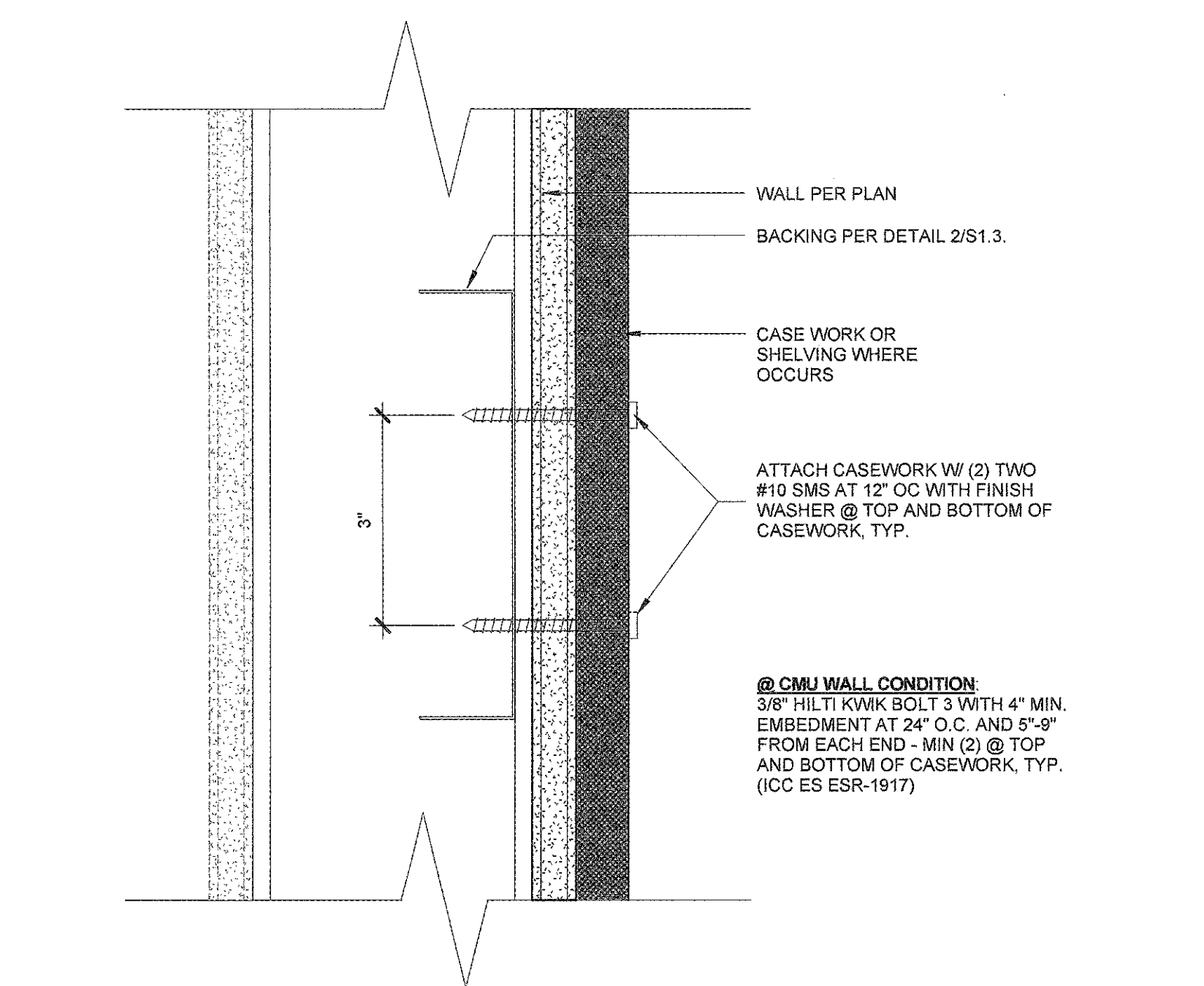

14 CASEWORK BACKING / BLOCKING DETAIL
A9.6.3 6" = 1'-0"

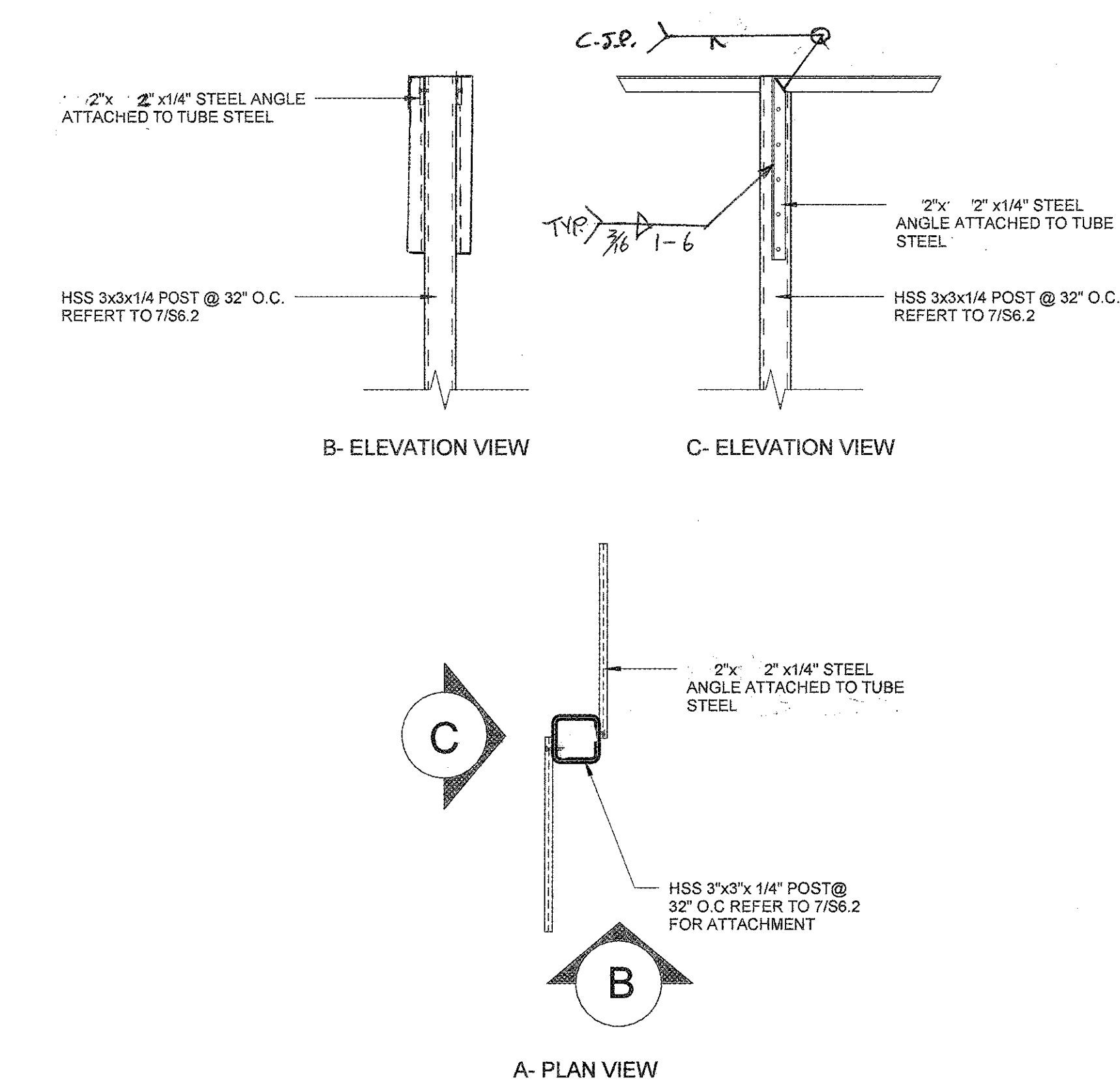

15 COUNTER & TRANSACTION WINDOW - PLAN
A9.6.3 1 1/2" = 1'-0"

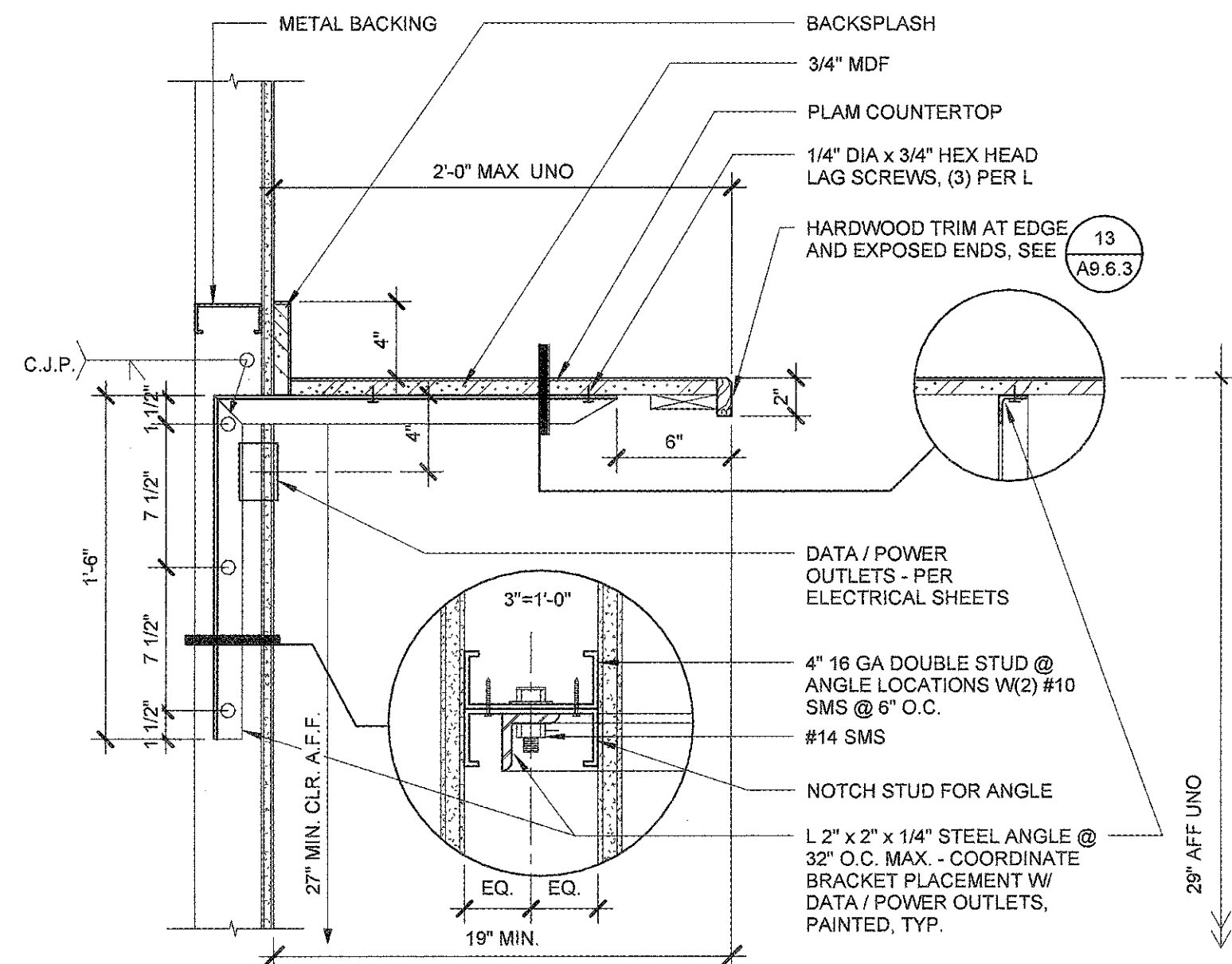

9 TYP. COUNTERTOP SUPPORT
A9.6.3 1 1/2" = 1'-0"

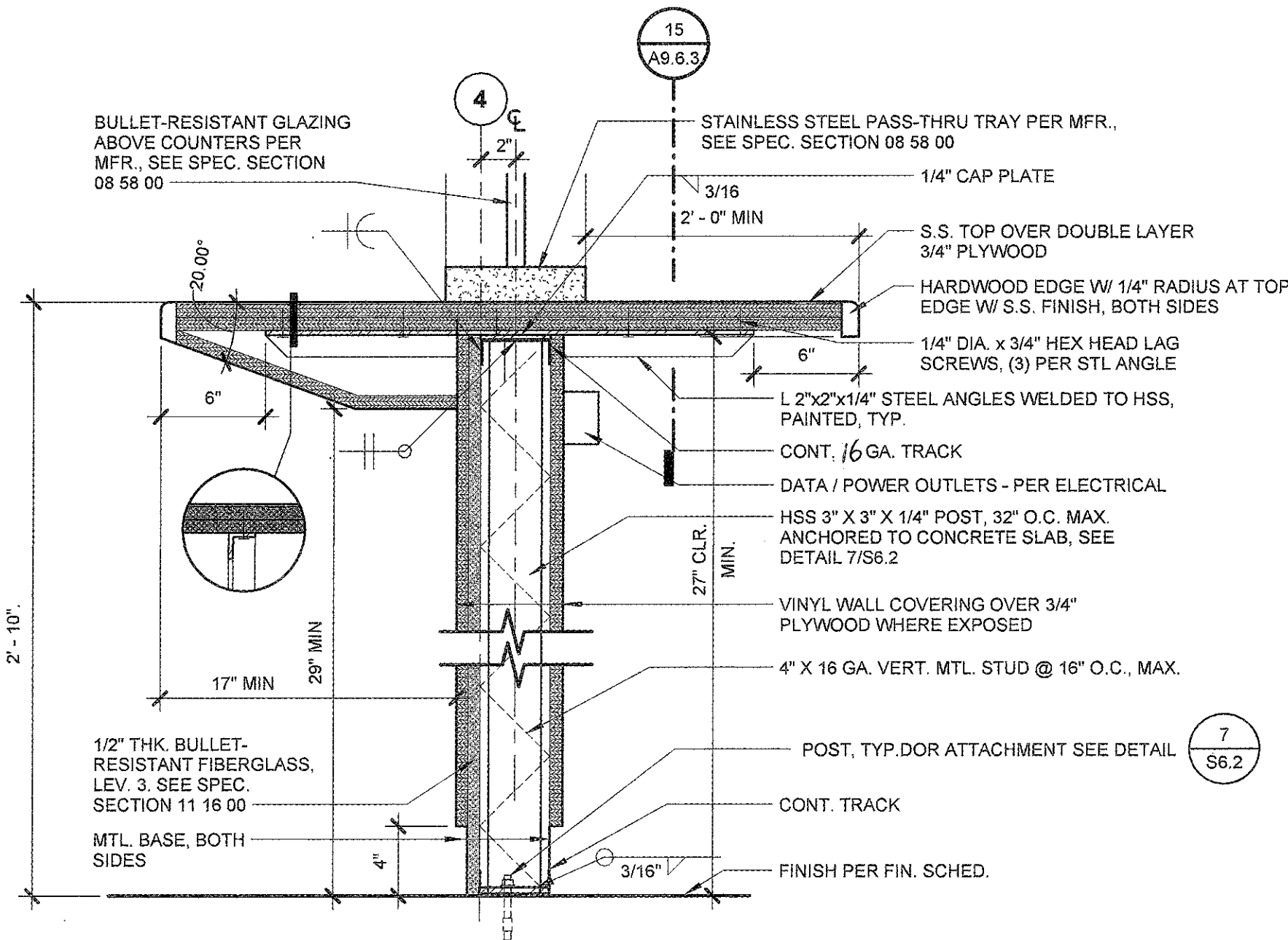

10 COUNTY & TRANSACTION WINDOW
A9.6.3 1 1/2" = 1'-0"

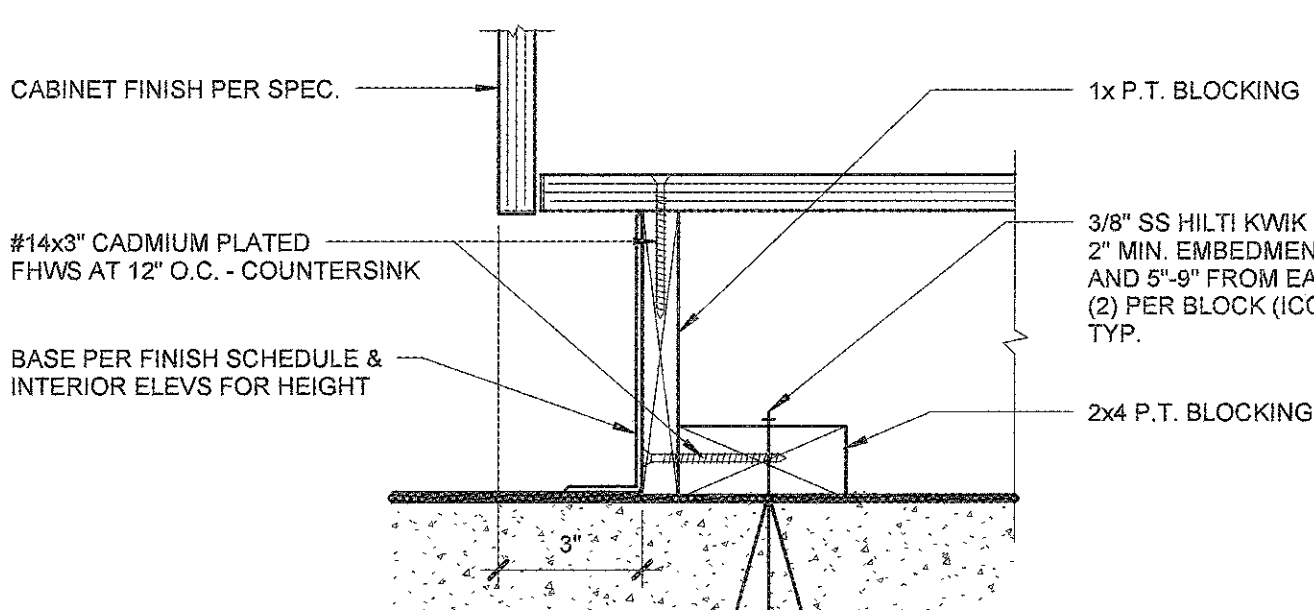

11 TYP. CABINET BASE ANCHORAGE
A9.6.3 3" = 1'-0"

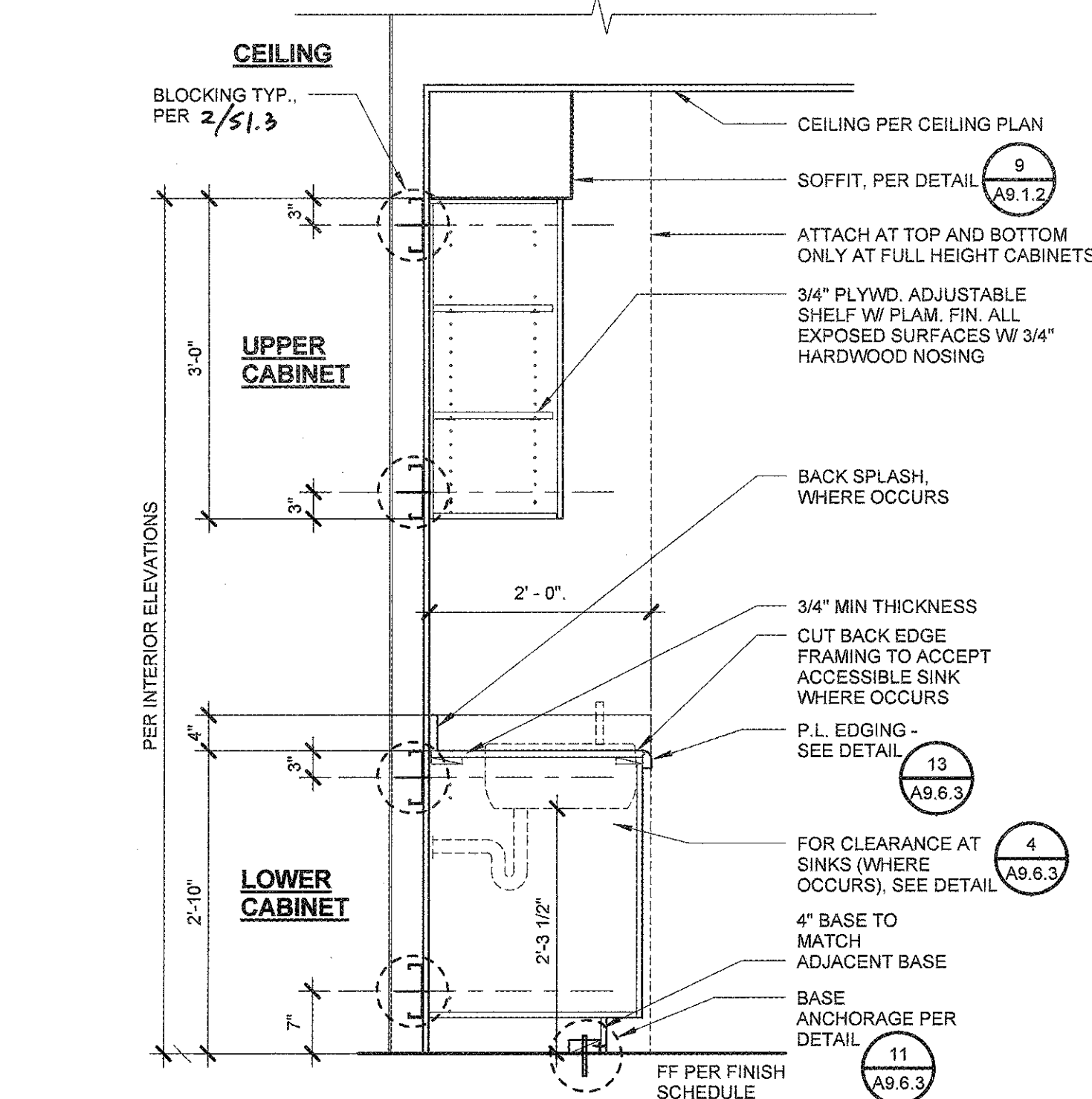

12 TYP. CABINERY ANCHORAGE
A9.6.3 3/4" = 1'-0"

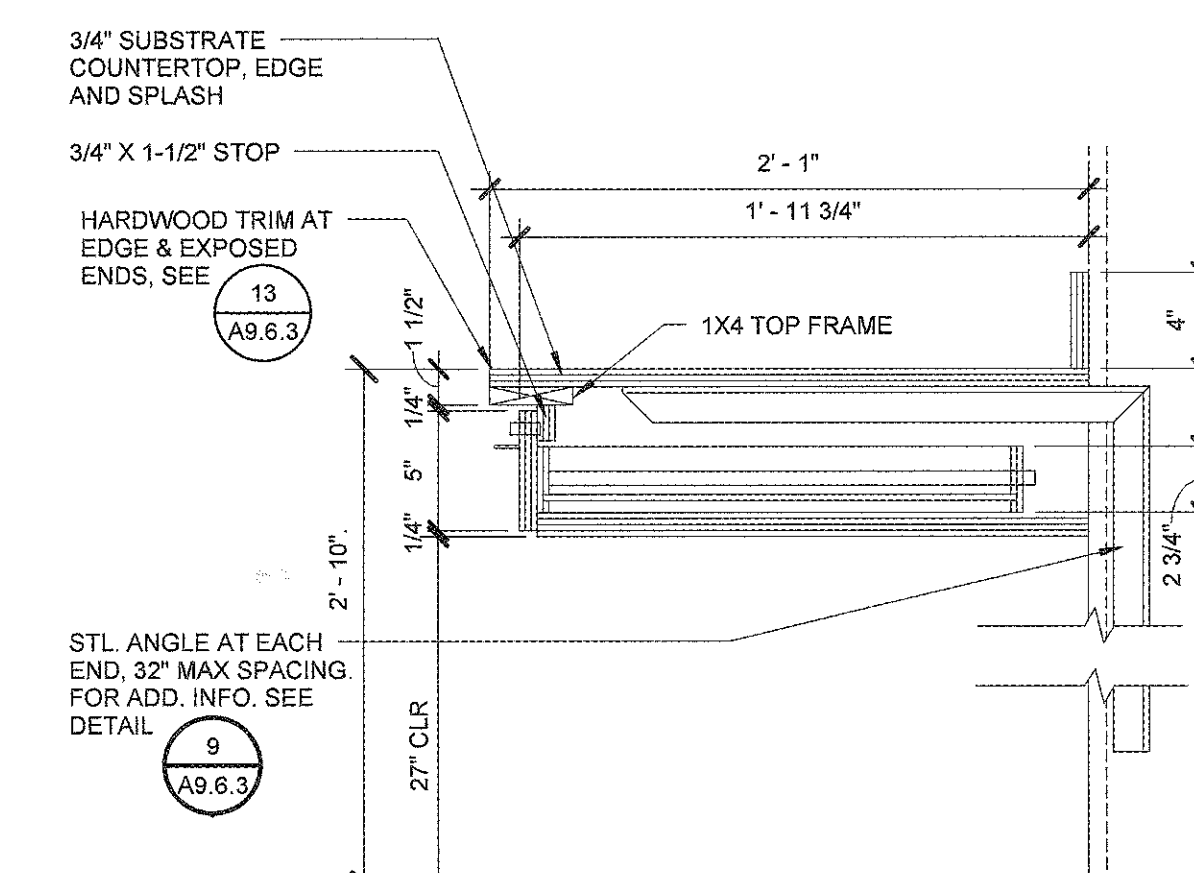

5 HANGING DRAWERS
A9.6.3 1 1/2" = 1'-0"

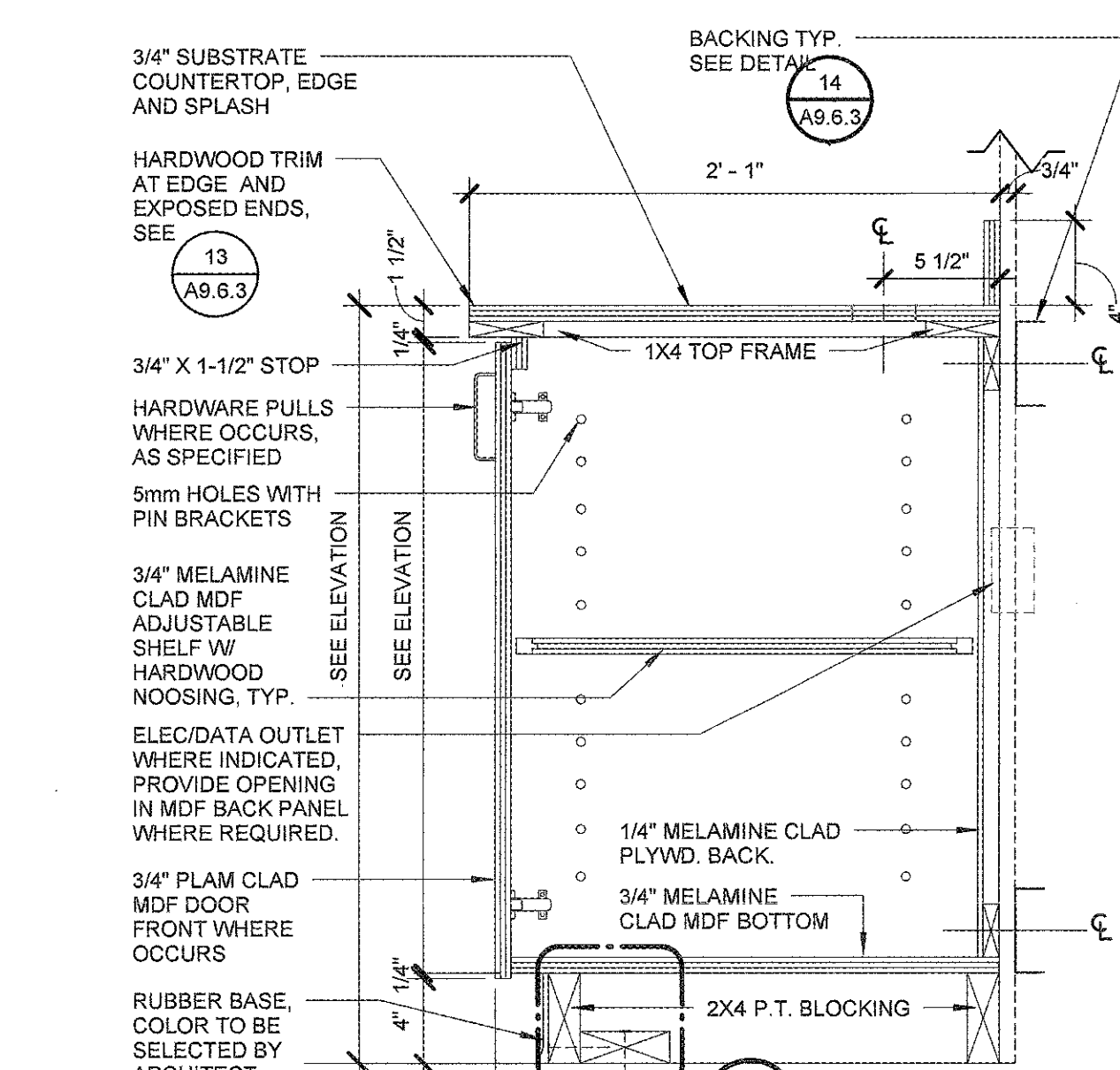

1 BASE CABINET
A9.6.3 1 1/2" = 1'-0"

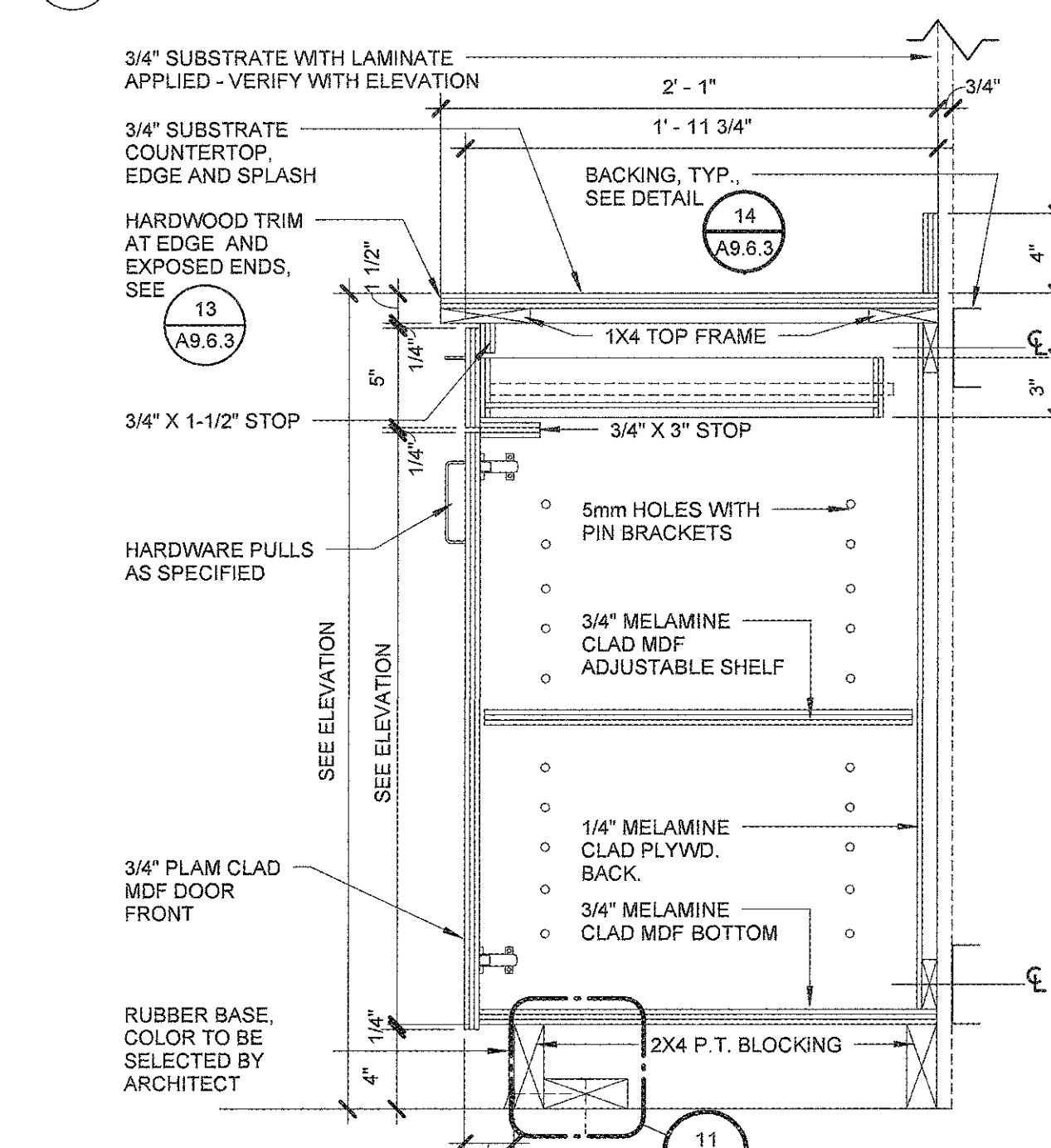

2 BASE CABINET W/ DRAWER
A9.6.3 1 1/2" = 1'-0"

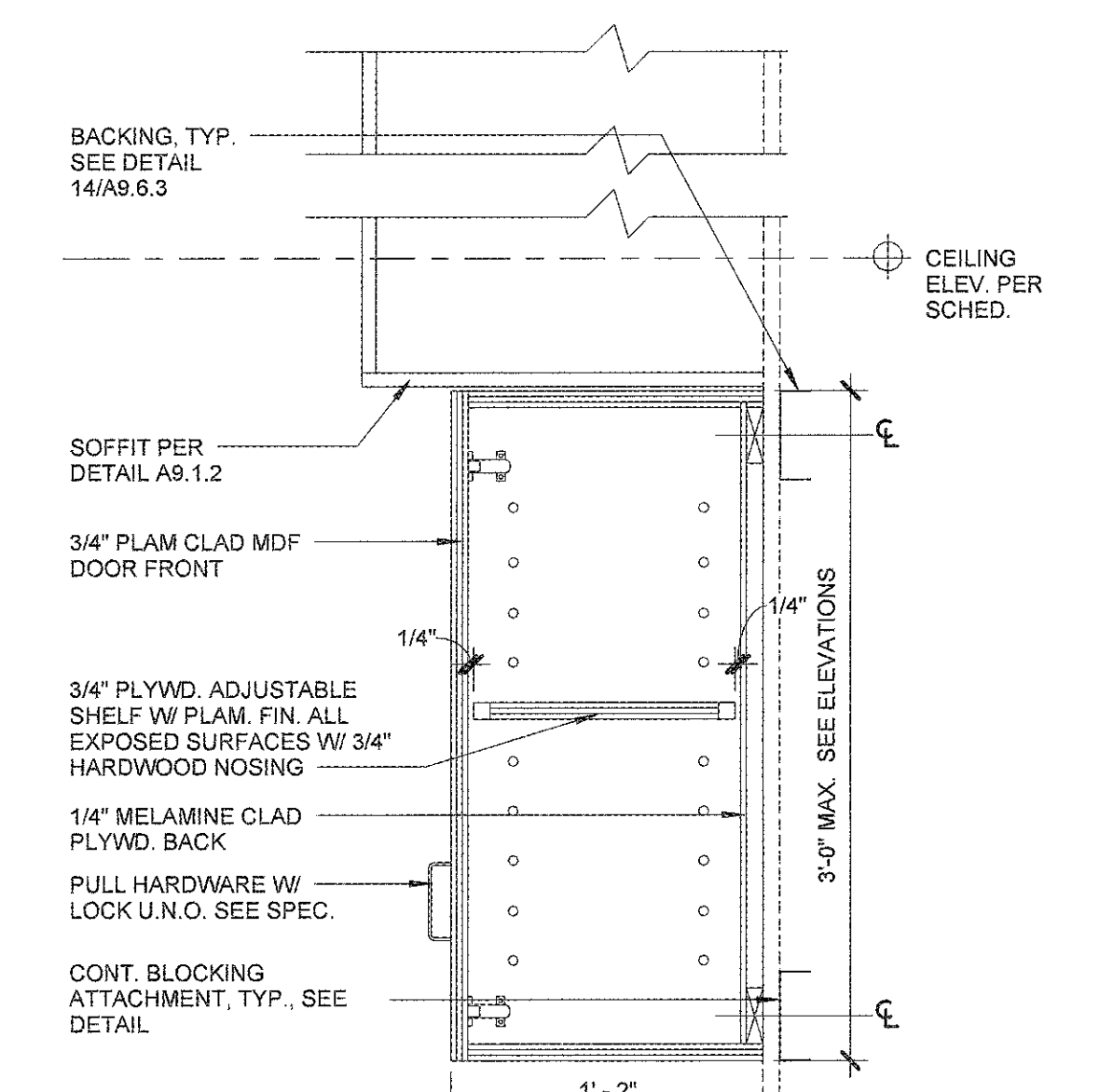

7 TYP. UPPER CABINETS
A9.6.3 1 1/2" = 1'-0"

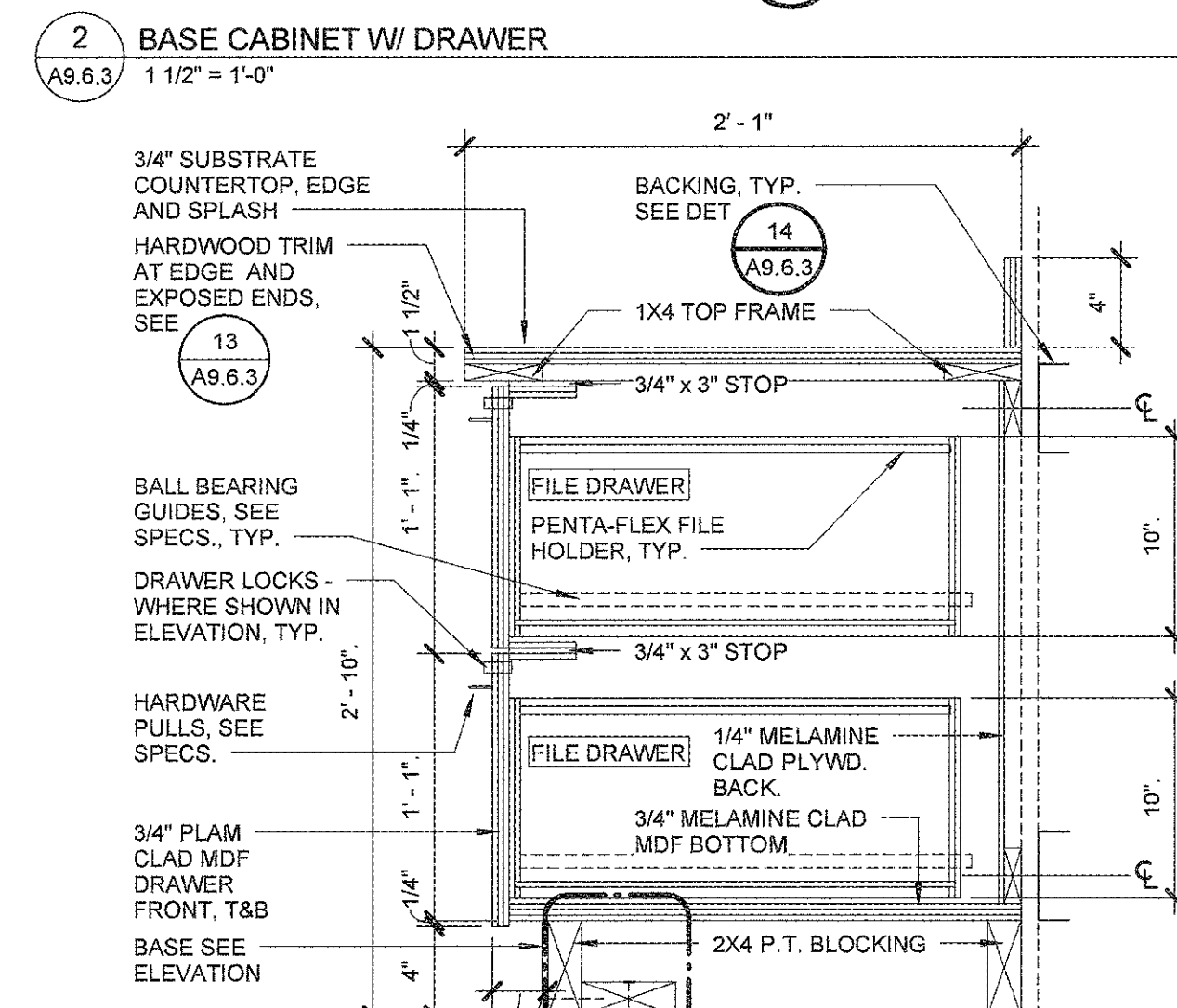

3 BASE CABINET 2 FILE DRAWERS
A9.6.3 1 1/2" = 1'-0"

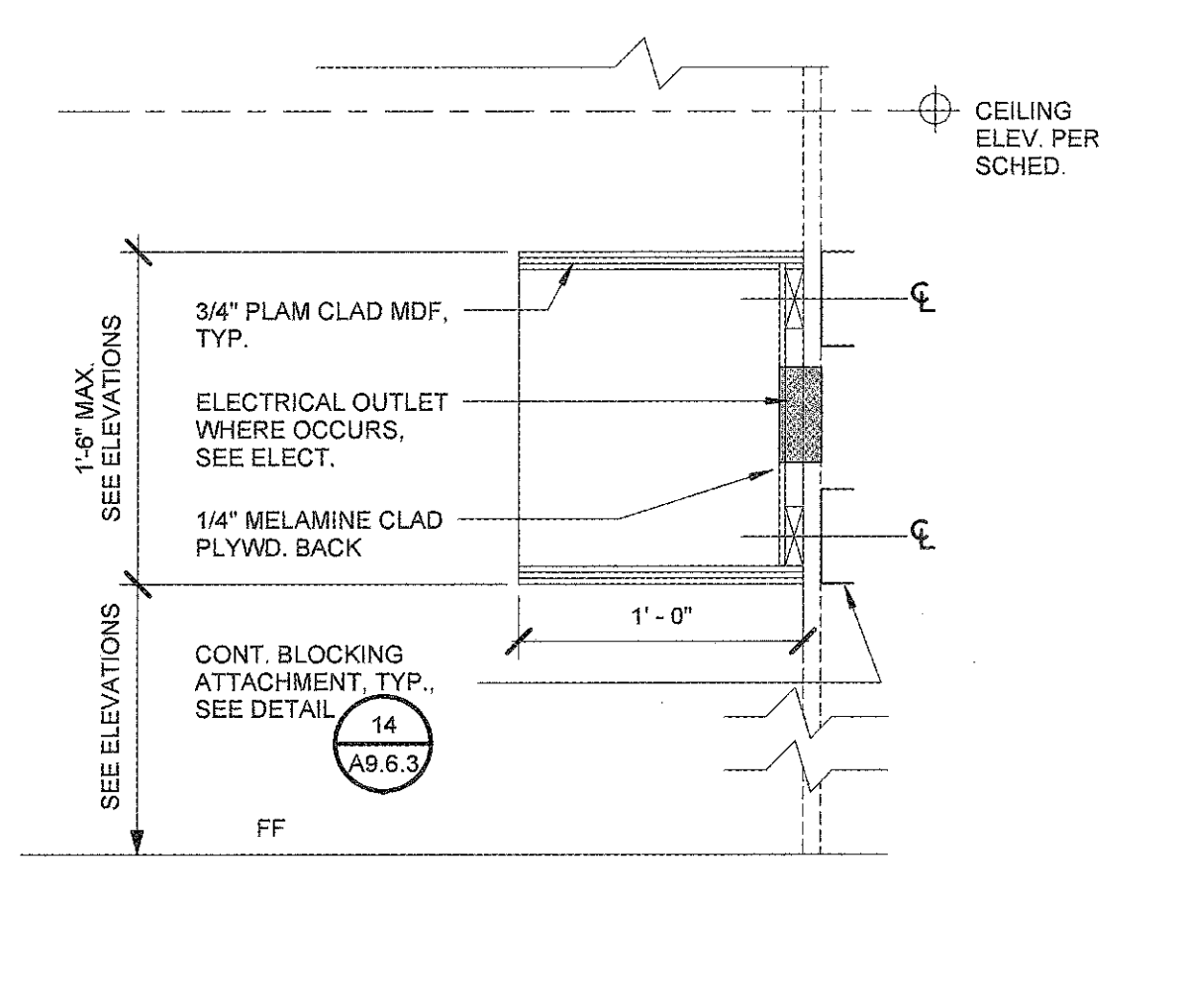

8 W306 UPPER OPEN CABINETS
A9.6.3 1 1/2" = 1'-0"

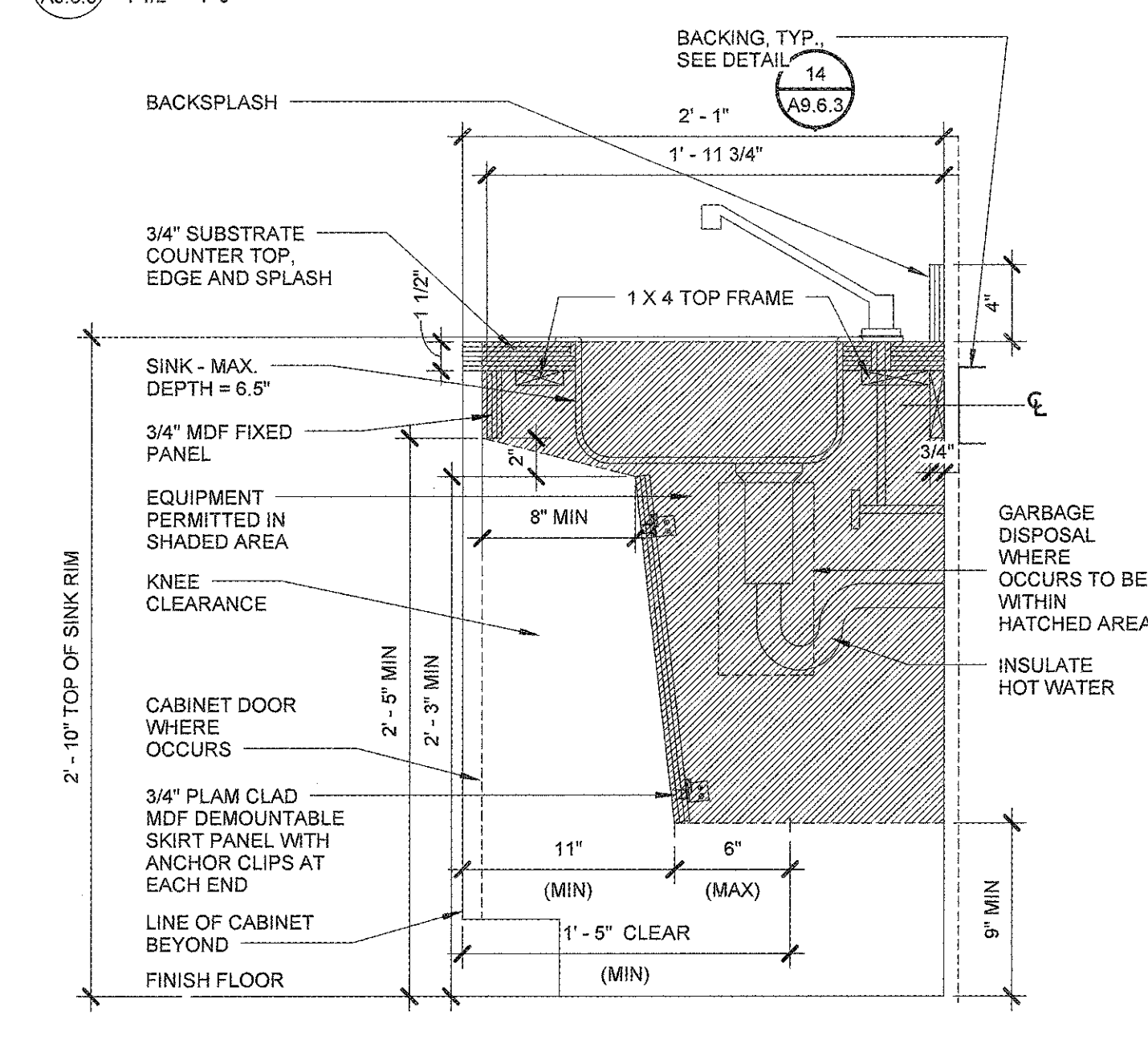

4 ACCESSIBLE SINK BASE
A9.6.3 1 1/2" = 1'-0"

POWDER ACTUATED FASTENERS

- ALL POWDER ACTUATED FASTENERS SHALL BE APPROVED FOR TYPE, APPLICATION AND INSTALLATION AND SHALL HAVE AN APPROVED ICC REPORT NUMBER.
- THE USE OF POWDER DRIVEN FASTENERS, IN TENSION, IS LIMITED TO SUPPORT OF MINOR LOADS SUCH AS DRYWALL OR ACOUSTICAL CEILINGS, DUCT WORK, CONDUIT, ETC. IN GENERAL, LOAD SHOULD BE LIMITED TO LESS THAN 100 POUNDS UNLESS APPROVED BY THE SEOR. POWDER ACTUATED FASTENERS SHALL NOT BE USED TO RESIST SEISMIC OR WIND LOADS.
- FASTENERS SHALL NOT BE INSTALLED UNTIL THE CONCRETE HAS REACHED ITS DESIGNATED STRENGTH.
- FASTENERS SHALL NOT BE INSTALLED IN CONCRETE WHOSE THICKNESS IS LESS THAN THREE TIMES THE PENETRATION REQUIRED, EXCEPT 1-1/8" PENETRATION IN 3-1/4" THICK FLOOR SLAB IS ACCEPTABLE.
- THE MINIMUM DISTANCE FROM THE EDGE OF CONCRETE TO CENTER OF ANCHOR IS 3 INCHES.
- FASTENERS IN THE UNDERSIDE OF CONCRETE SLABS ON METAL DECKING SHALL BE PLACED IN THE THICK PORTION OF THE SLAB.
- FASTENERS SHALL BE INSTALLED BY A PRE-QUALIFIED OPERATOR ACCORDING TO THE ICC REPORT AND TESTED AS FOLLOWS: INSPECTOR SHALL OBSERVE THE TESTING OF THE FIRST 10 FASTENER INSTALLATIONS. A TEST "PULL-OUT" LOAD OF NOT LESS THAN TWICE THE DESIGN LOAD, OR 200 POUNDS, WHICHEVER IS GREATER, SHALL BE APPLIED TO THOSE 10 PINS IN SUCH A MANNER AS NOT TO RESIST THE SPALLING TENDENCY OF THE CONCRETE SURROUNDING THE PINS. RANDOM TESTS UNDER THE PROJECT INSPECTOR'S SUPERVISION SHALL BE MADE OF APPROXIMATELY 1 IN 10 PINS EXCEPT WHEN THE DESIGN LOAD IS 100 POUNDS OR MORE, ONE HALF OF THE PINS SHALL BE TESTED. SHOULD FAILURE OCCUR ON ANY PIN TESTED, ALL OF THE NEXT 20 INSTALLATIONS MUST BE TESTED AND UNFAIR PINS REPLACED.
- WHEN INSTALLING POWDER DRIVEN PINS IN EXISTING NON-PRESTRESSED REINFORCED CONCRETE, USE CARE AND CAUTION TO AVOID HITTING OR DAMAGING THE EXISTING REINFORCING BARS.

QUALITY CONTROL

- UNLESS NOTED OTHERWISE, MATERIALS SHALL CONFORM TO THE PROVISIONS OF THE 2010 CALIFORNIA BUILDING CODE AND TESTS AND INSPECTIONS SHALL BE PERFORMED BY THE APPROVED TESTING AGENCY AND/OR THE JOB INSPECTOR WHO IS APPROVED BY DSA, THE ARCHITECT AND THE STRUCTURAL ENGINEER. COORDINATE AND WORK WITH THE DSA TESTING, INSPECTION AND OBSERVATION (TIO) PROGRAM FOR THE PROJECT.

DESIGN CRITERIA

GENERAL

- STRUCTURE HAS BEEN DESIGNED TO COMPLY WITH ASCE/SEI 7-05 (MINIMUM DESIGN LOADS FOR BUILDINGS AND OTHER STRUCTURES) AS MODIFIED BY 2010 CALIFORNIA BUILDING CODE AND SUPPLEMENTS.
- LIVE LOADS:

TYPICAL ROOF	20 PSF (REDUCIBLE PER CODE)
MECHANICAL ROOM	50 PSF (REDUCIBLE PER CODE) AND INCLUDING 15 PSF PARTITION ALLOWANCE ON FLOOR.
- WIND DESIGN DATA

1. BASIC WIND SPEED (3-SECOND GUST)	110 mph
2. WIND IMPORTANCE FACTOR, I AND OCCUPANCY CATEGORY	1.0, IV
3. WIND EXPOSURE	C

EARTHQUAKE DESIGN DATA

1. SEISMIC IMPORTANCE FACTOR, I AND OCCUPANCY CATEGORY	1.5, IV
2. MAPPED SPECTRAL ACCELERATIONS, S_g AND S_1	1.672g, 0.611g
3. SITE CLASS	D
4. SITE SPECIFIC SPECTRAL RESPONSE COEFFICIENTS, S_{DS} AND S_{D1}	1.114g, 0.611g
5. SEISMIC DESIGN CATEGORY	E
6. BASIC SEISMIC-FORCE-RESISTING SYSTEM(S)	SPECIAL REINFORCE MASONRY SHEAR WALLS IN BOTH DIRECTIONS, $R=5$, $\sqrt{A_o} \geq 1/2$, $C_d=3$, $1/2$
7. SEISMIC BASE SHEAR	$V=C_d W = 0.334W$

SEISMIC BRACING OF MECHANICAL SYSTEMS & FIRE SPRINKLERS

- BRACING OF ALL DUCTS, PIPES, CONDUITS, FIRE SPRINKLERS, AND ANY OTHER SYSTEMS SHALL MEET 2013 CBC AND TITLE 24 REQUIREMENTS.
- FIRE SPRINKLERS SHALL BE SEISMICALLY BRACED IN ACCORDANCE WITH THE 2010 VERSION OF NFPA13 AND SHALL HAVE ROD STIFFENERS ON ALL HANGER RODS ADJACENT TO LATERAL BRACING. (ROD STIFFENER SHALL BE PER PAGE 58 OF OSHPD OPA-0114).
- PRE-APPROVED SYSTEMS SHALL BE USED AND HAVE "OPA" OSHPD APPROVAL.
- CONTRACTOR SHALL NOT MIX COMPONENTS OF TWO OR MORE PRE-APPROVED BRACING SYSTEMS. ONLY ONE PRE-APPROVED BRACING SYSTEM SHALL BE USED FOR RUN OF PIPE, DUCT OR CONDUIT. ANY SUBSTITUTION OF A COMPONENT OF A PRE-APPROVED BRACING SYSTEM REQUIRES DSA REVIEW AND APPROVAL.
- INDEPENDENTLY ENGINEERED SYSTEMS SHALL BE DESIGNED AND STAMPED BY A LICENSED CALIFORNIA STRUCTURAL ENGINEER.
- SHOP DRAWINGS SHOWING ALL BRACING LOCATIONS AND DETAILS OF ALL CONNECTIONS ARE REQUIRED FOR ALL PRE-APPROVED SYSTEMS. SUBMITTAL SHALL INCLUDE:
 - REACTION AT SUPPORTS.
 - REACTION AT BRACES.
 - PRE-APPROVED SYSTEM ASSEMBLY DETAILS.
 - SHOP DRAWINGS TO BE SUBMITTED FOR FINAL APPROVAL.

METAL STUDS

- METAL STUDS SHALL BE PER STEEL STUD MANUFACTURERS ASSOC. (OR APPROVED EQUAL), ICC ESR-3064P.
- ALL STEEL STUDS SHALL BE GALVANIZED.
- STUD FRAMING SHALL BE IN ACCORDANCE WITH AISI, "SPECIFICATIONS FOR DESIGN OF COLD FORMED STEEL STRUCTURAL MEMBERS".
- ALL 18GA (43mil) AND LIGHTER SECTIONS SHALL CONFORM TO ASTM A1003, STRUCTURAL GRADE 33 TYPE H, OR ASTM A653 SS GRADE 33. ALL OTHER SECTIONS SHALL CONFORM TO ASTM A1003 STRUCTURAL GRADE 50 TYPE H, OR ASTM A653 SS GRADE 50 CLASS 1.

MASONRY

- CONCRETE BLOCKS SHALL BE OF SIZES SHOWN ON THE DRAWINGS, TYPE AND COLOR AS SELECTED BY THE ARCHITECT AND CONFORM TO ASTM C-90, GRADE N-1. BLOCK SHALL BE MEDIUM WEIGHT UNITS, fm = 1,900 PSI, fm = 1,500 PSI. ALL CMU UNITS SHALL BE LAYED IN RUNNING BOND, UNLESS OTHERWISE ON THE DRAWINGS.
- COARSE GROUT MIX SHALL BE 1:3:2 PORTLAND CEMENT TO SAND TO PEA GRAVEL WITH 1/10 PART LIME PUTTY OR HYDRATED LIME, 2000 PSI.
- MORTAR MIX SHALL BE 1:3 PORTLAND CEMENT TO SAND WITH NOT MORE THAN ONE-HALF NOR LESS THAN ONE-QUARTER PART LIME PUTTY, TYPE M OR S, 1800 PSI.
- ALL REINFORCING SHALL HAVE A MINIMUM COVERAGE OF ONE BAR DIAMETER (1/2" MIN.) OF GROUT AND VERTICAL BARS SHALL BE PLACED IN THE CENTER OF THE WALL UNLESS SHOWN OTHERWISE.
- GROUT CELLS SOLID IN ALL WALLS. REINFORCING SHALL BE SECURELY HELD IN PLACE. GROUT IN 4" MAXIMUM LOW LIFTS FOR CMU WALLS PER SECTION 1.19 OF BUILDING CODE REQUIREMENTS FOR MASONRY STRUCTURES (TMS 402-08/ACI 530-08/ASCE 5-08)
- NO PIPES OR DUCTS SHALL BE PLACED IN MASONRY UNLESS NOTED OR DETAILED SPECIFICALLY.
- BOLTS SHALL BE GROUTED SOLID WITH 1" MIN. GROUT BETWEEN BOLT AND MASONRY AT BLOCK FACE.
- ALL CONCRETE TO RECEIVE MASONRY SHALL BE SANDBLASTED CLEAN.
- BLOCK LAYING AND GROUTING TO BE CONTINUOUSLY INSPECTED BY SPECIAL INSPECTOR.

HIGH LIFT GROUTED CONSTRUCTION

- WHERE HIGH LIFT GROUTING IS USED, CONFORM TO SECTION 1.19 OF BUILDING CODE REQUIREMENTS FOR MASONRY STRUCTURES (TMS 402-08/ACI 530-08/ASCE 5-08) IT SHALL BE APPROVED BY THE ARCHITECT IN ACCORDANCE WITH TABLE 1.19.1 (OF REQUIREMENTS FOR MASONRY STRUCTURES (TMS 402-08/ACI 530-08/ASCE 5-08)
- CLEANOUT OPENINGS SHALL BE PROVIDED AT THE BOTTOM OF EACH POUR OF GROUT. ANY OVERHANGING MORTAR OR OTHER DEBRIS SHALL BE REMOVED FROM THE INSIDES OF CELL WALLS.
- THE FOUNDATION OR OTHER HORIZONTAL CONSTRUCTION JOINTS SHALL BE CLEANED OF ALL LOOSE MATERIAL AND MORTAR DROPPINGS BEFORE EACH POUR.
- THE CLEANOUTS SHALL BE SEALED BEFORE GROUTING. ALL CELLS SHALL BE FILLED WITH GROUT.
- AN APPROVED ADMIXTURE THAT REDUCES EARLY WATER LOSS AND PRODUCES AN EXPANSIVE ACTION SHALL BE USED IN THE GROUT.
- HIGH LIFT GROUTING SHOULD COMPLY WITH DSA IR 21-2.10 AND 2010 CBC SECTION 2104A.5.1.2.3

LEGEND

MATERIALS

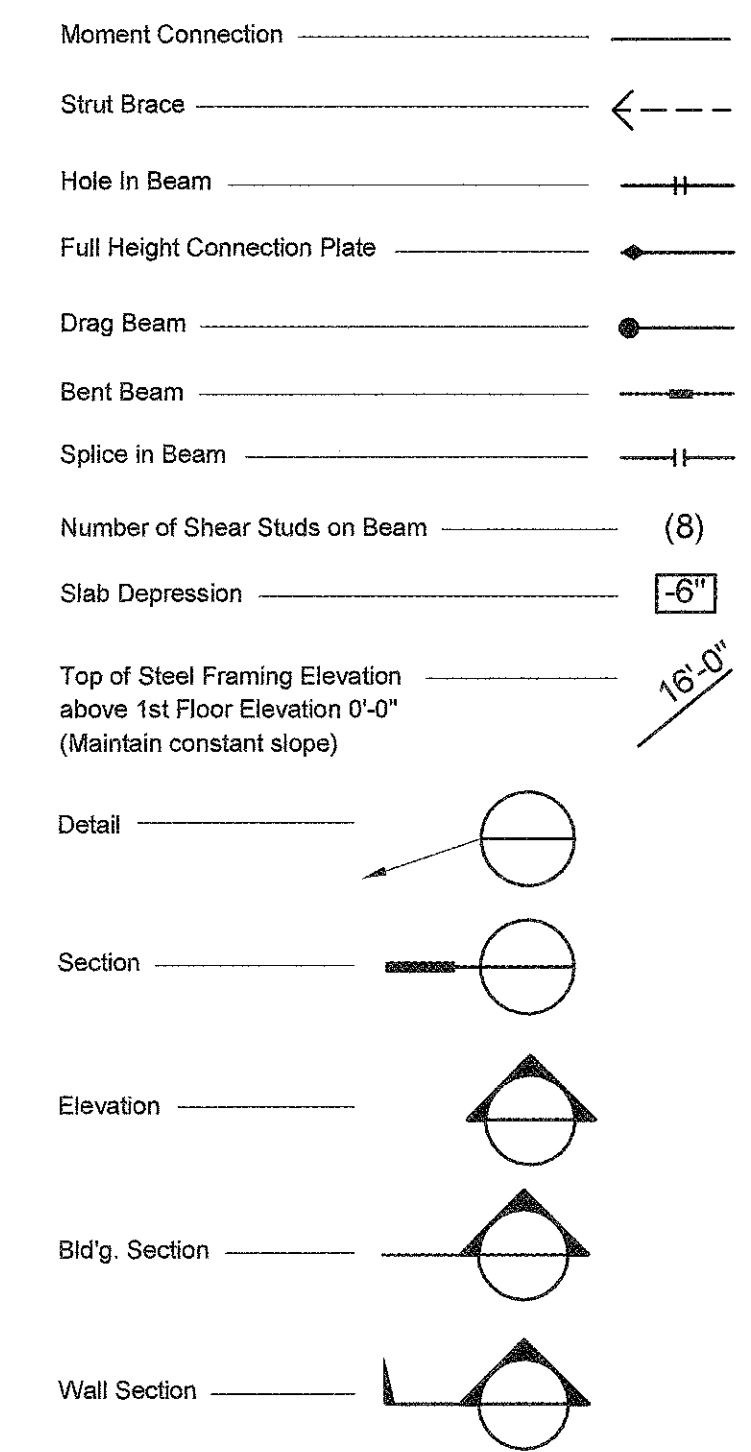
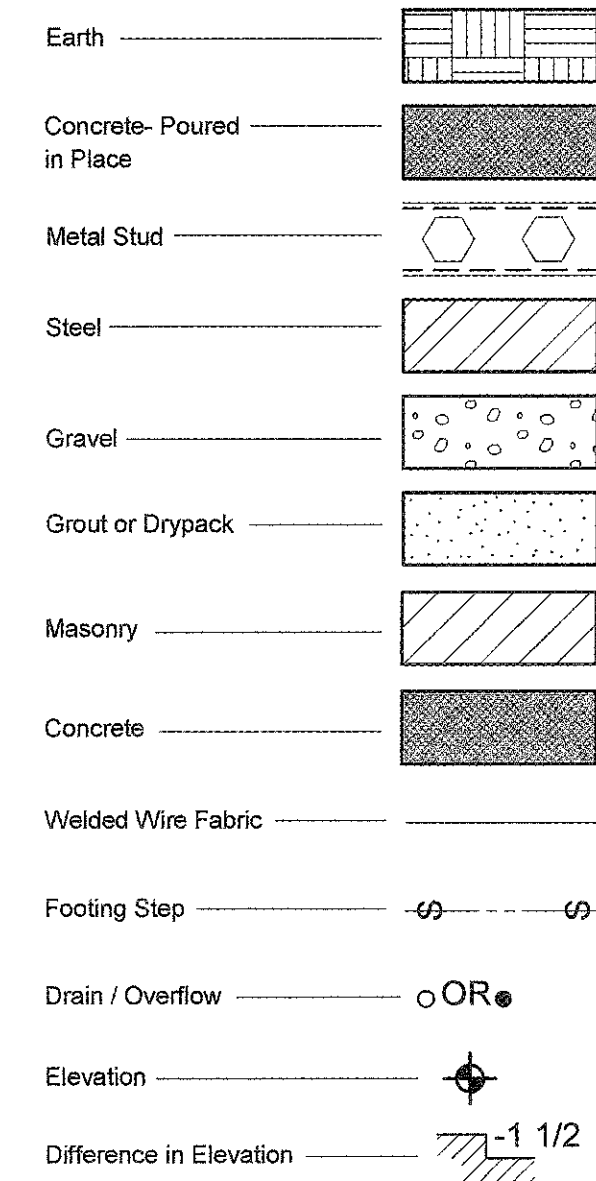

ABBREVIATIONS

□ Diameter	Horiz. Horizontal
# Number of pounds	Intr. Interior
@ At	Jt. Joint
CL Center line	Lt. Wt. Lightweight
-3" Slab depression	M.B. Machine Bolt
A.B. Anchor Bolt	Max. Maximum
Anch. Anchor	Mechl. Mechanical
B.O.F. Bottom of Footing	Mfr. Manufacturer
Beam Beam	Min. Minimum
Bm. Beam	Mtl. Metal
Botl. Bottom	N.I.C. Not in Contract
Bwn. Between	N.T.S. Not to Scale
C.L. Center Line	No. Number
C.J. Control Joint	o.c. On Center
C.J.P. Complete Joint Penetration	P.D.F. Power Driven Fasteners
Clr. Clear	P.H. Penthouse
Col. Column	Pl. Plate
Conc. Concrete	Pics. Places
Cont. Continuous	P.J.P. Partial Joint Penetration
Det. Detail	Reinf. Reinforcing
Dim. Dimension	S. Footing Step
Dwg. Drawing	S.F.R.S. Seismic Force Resisting System
Dwl. Dowel	Sched. Schedule
E.F. Each Face	Sect. Section
E.W. Each Way	Sepr. Separation
Ea. Each	Sim. Similar
EL Elevation	Spec. Specification
Elect. Electrical	Sq. Square
Elev. Elevator or Elevation	Std. Standard
E.O.S. Edge of Slab	Stiff. Stiffener
Exist. Existing	St. Steel
Exp. Expansion	Suppt. Support
Extr. Exterior	Sym. Symmetrical
F.O.C. Face of Concrete	T.C.J. Typical Construction Joint
F.O.S. Face of Slud	T.O. Top of
F.O.W. Face of Wall	T.O.S. Top of Steel
Fdn. Foundation	T.O.W. Top of Wall
Fin. Finish	Thk. Thick
Fir. Floor	Typ. Typical
Frmg. Framing	V.O.J. Verify on Job
Fig. Footing	V.O.S. Verify on Site
Ga. Gauge	Vert. Vertical
Galv. Galvanized	w/ With
Gr. Bm. Grade Beam	Wt. Weight
H.S.B. High Strength Bolt	U.N.O. Unless Noted Otherwise

GENERAL NOTES

NONE 1

1300 Dove Street, Suite 100
Newport Beach, CA 92660
T: 949.698.1400 F: 949.698.1433
www.littleonline.com

This drawing and the design shown are the property of Little Diversified Architectural Consulting. The reproduction, copying or other use of this drawing without their written consent is prohibited and any infringement will be subject to legal action.

© Little 2016

**COMPTON
CCD**

CAMPUS PUBLIC SAFETY BUILDING

1111 EAST ARTESIA BOULEVARD,
COMPTON CALIFORNIA 90221

IDENTIFICATION STAMP
DIV. OF THE STATE ARCHITECT
OFFICE OF REGULATION SERVICES

FILE NO: 19-C1
AR: 03-117673

AC: [initials] FS: [initials] SS: [initials]
DATE: DEC 17 2011

TTG

901 Via Piemonte Suite 400
Ontario, California 91764
Phone: 909.477.6915 Fax: 909.477.6916
www.ttgcorp.com Project No. 0216.4677.00

REGISTERED PROFESSIONAL ENGINEER
No. S2292
Exp. 03/2025
STATE OF CALIFORNIA

PRINCIPAL IN CHARGE
RITA S. CARTER
PROJECT MANAGER
SHOJI TAKESHIMA / DAVID PHAN
DRAWN BY
GERARDO CARRANZA

NO	REASON	DATE

PROJECT NUMBER
913-4675-01

DATE DATE
11/21/17

SHEET NO.
S0.2

FOOTINGS POURED AGAINST EARTH	3"
FORMED SURFACES BELOW GRADE	2"
WALLS: EXTERIOR SURFACES ABOVE GRADE	2"
INTERIOR SURFACES	1"
STRUCTURAL SLABS, TOP AND BOTTOM	3/4"
SLABS ON GRADE, TOP	1"

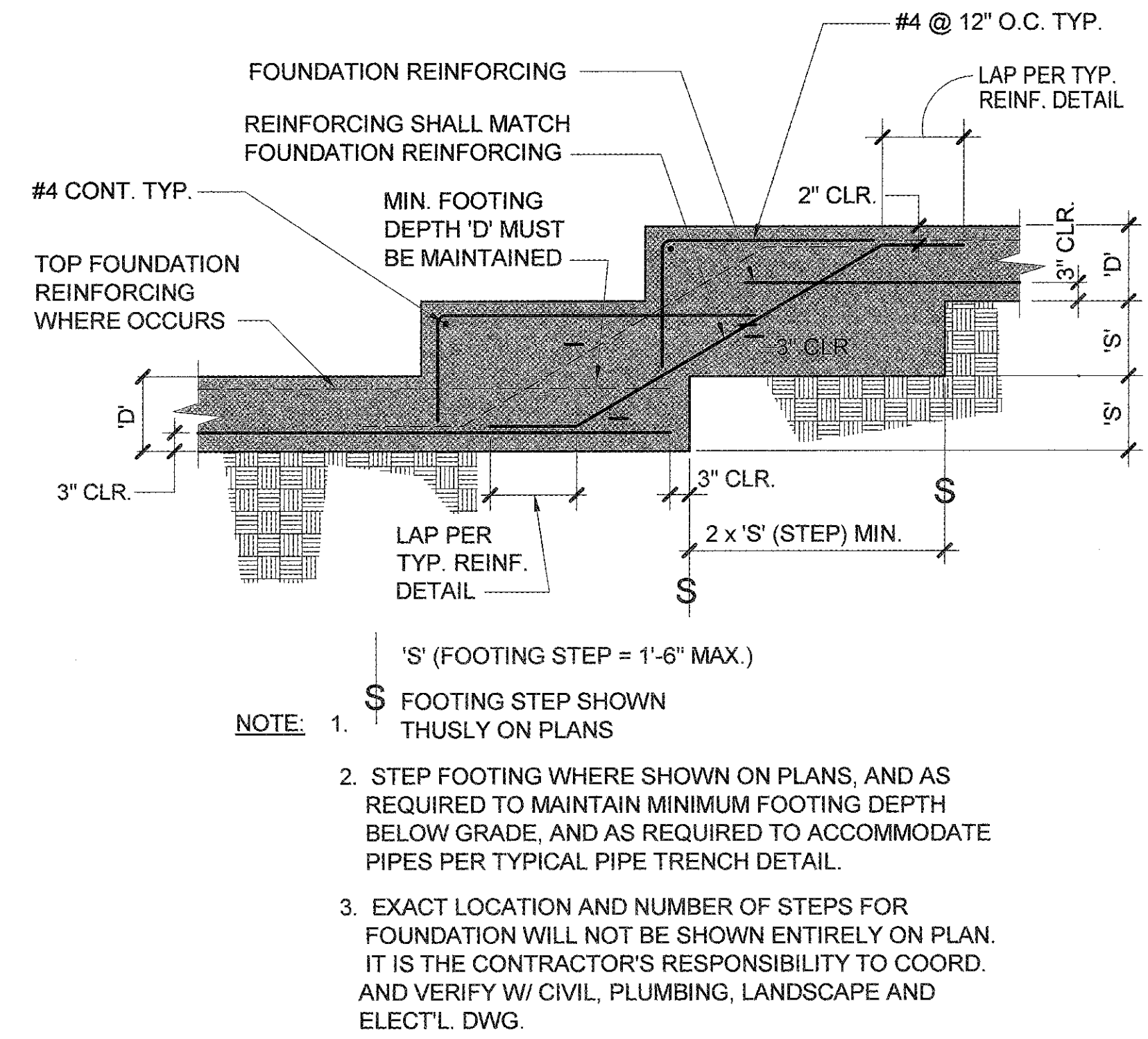

- NOTE:
- FOOTING STEP SHOWN THUSLY ON PLANS
 - STEP FOOTING WHERE SHOWN ON PLANS, AND AS REQUIRED TO MAINTAIN MINIMUM FOOTING DEPTH BELOW GRADE, AND AS REQUIRED TO ACCOMMODATE PIPES PER TYPICAL PIPE TRENCH DETAIL.
 - EXACT LOCATION AND NUMBER OF STEPS FOR FOUNDATION WILL NOT BE SHOWN ENTIRELY ON PLAN. IT IS THE CONTRACTOR'S RESPONSIBILITY TO COORD. AND VERIFY W/ CIVIL, PLUMBING, LANDSCAPE AND ELECT'L DWG.

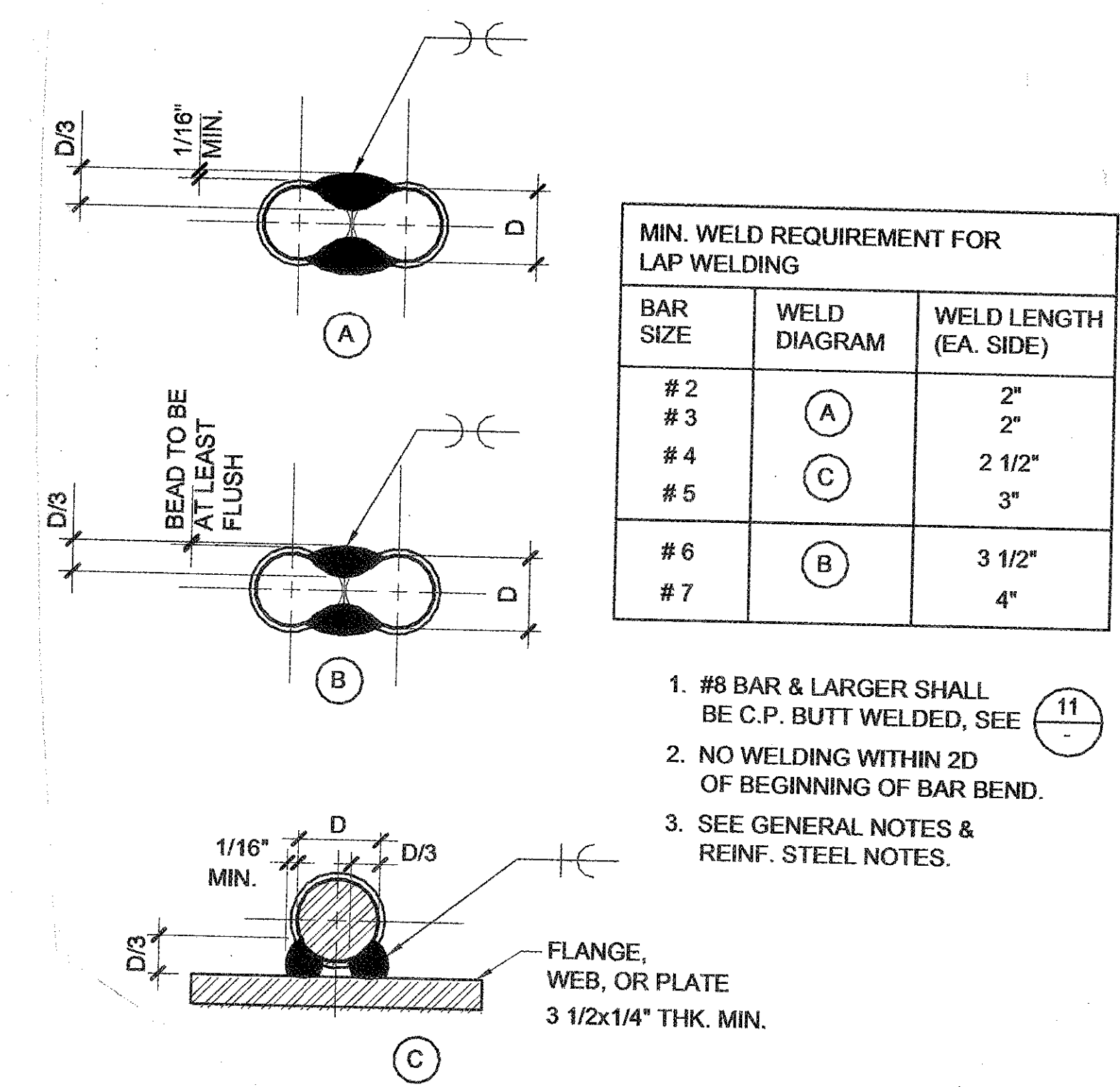

- #8 BAR & LARGER SHALL BE C.P. BUTT WELDED, SEE (11)
- NO WELDING WITHIN 2D OF BEGINNING OF BAR BEND.
- SEE GENERAL NOTES & REINF. STEEL NOTES.

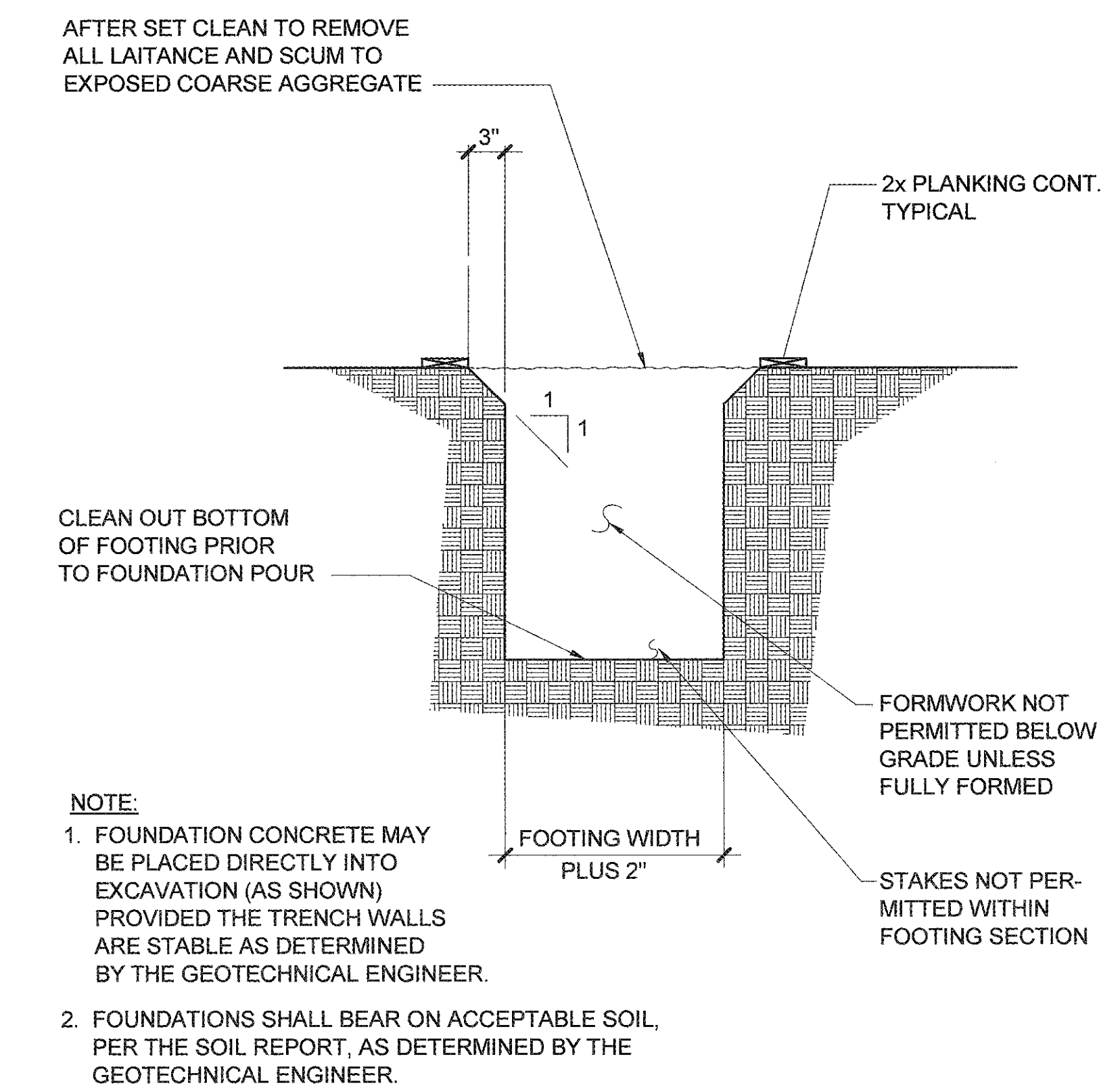

- NOTE:
- FOUNDATION CONCRETE MAY BE PLACED DIRECTLY INTO EXCAVATION (AS SHOWN) PROVIDED THE TRENCH WALLS ARE STABLE AS DETERMINED BY THE GEOTECHNICAL ENGINEER.
 - FOUNDATIONS SHALL BEAR ON ACCEPTABLE SOIL, PER THE SOIL REPORT, AS DETERMINED BY THE GEOTECHNICAL ENGINEER.

CONC. PROTECTION FOR REINF. STEEL NONE 12

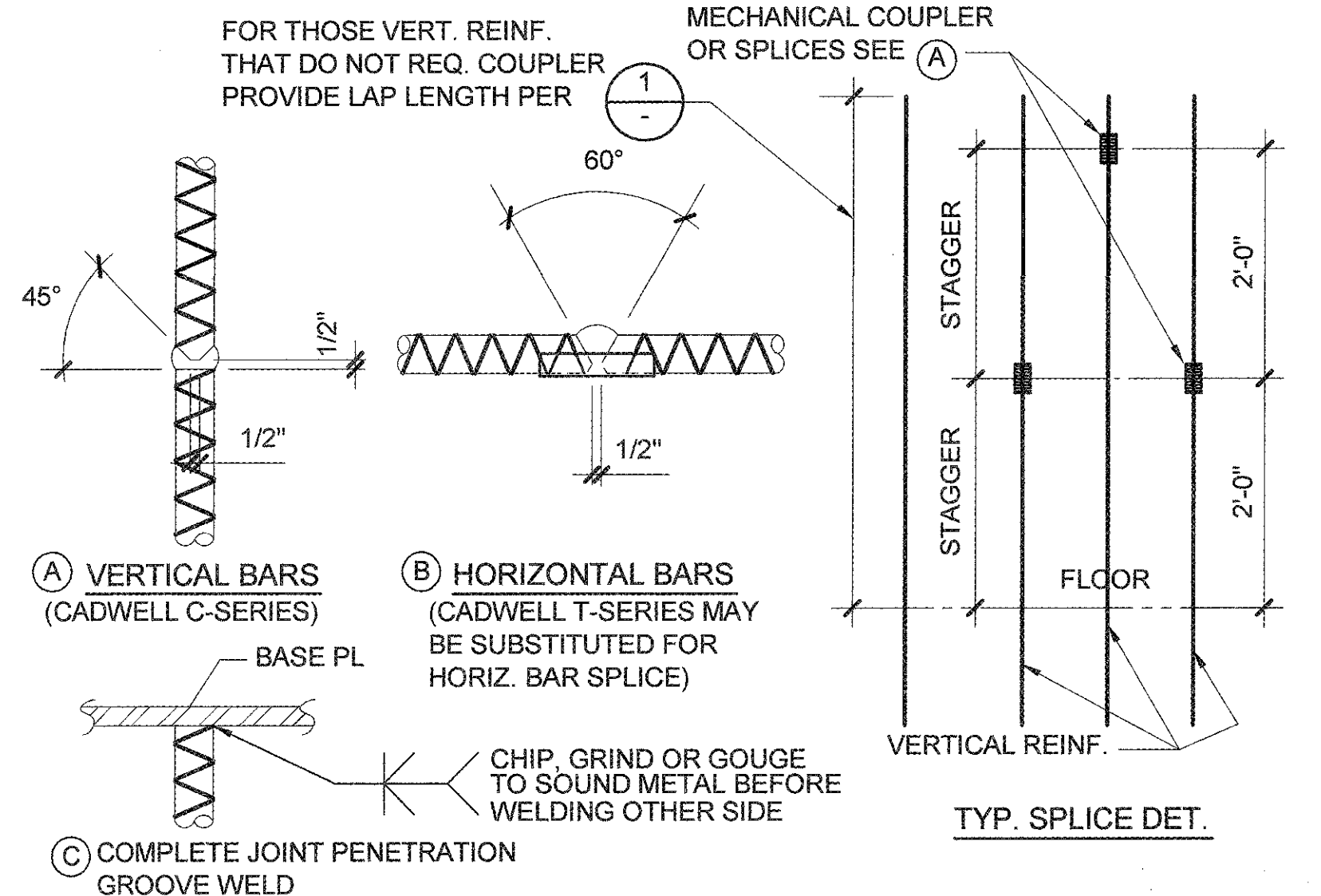

- NOTES:
- A PRE-QUALIFICATION TENSION TEST SHALL BE MADE BY AN APPROVED TESTING LABORATORY ON SAMPLES OF EVERY SIZE BAR BEING WELDED.
 - MATERIALS, CONDITIONS AND WELDING PROCEDURES UTILIZED SHALL COMPLY WITH THE CURRENT APPLICABLE BUILDING CODE AND THE REQUIREMENTS OF THE GOVERNING INSPECTION AGENCY AND APPROVED BY DSA.
 - ALL COSTS INCURRED FOR OBTAINING APPROVALS SHALL BE BORNE BY THE GENERAL CONTRACTOR.
 - REINFORCING COUPLERS IN LIEU OF BUTT WELD AS SHOWN ABOVE TO BE PROVIDED AT CONTRACTOR'S OPTION. COUPLERS SHALL BE TAPERED THREADED SPLICING COUPLERS (ACCORDING TO ASTM 439.4R & WITH ICC APPROVAL) TO DEVELOP THE FULL ACI TENSION SPLICE STRENGTH REQUIREMENTS 125% OF SPECIFIED YIELD.

TYPICAL STEPPED FOOTING DETAIL NONE 9

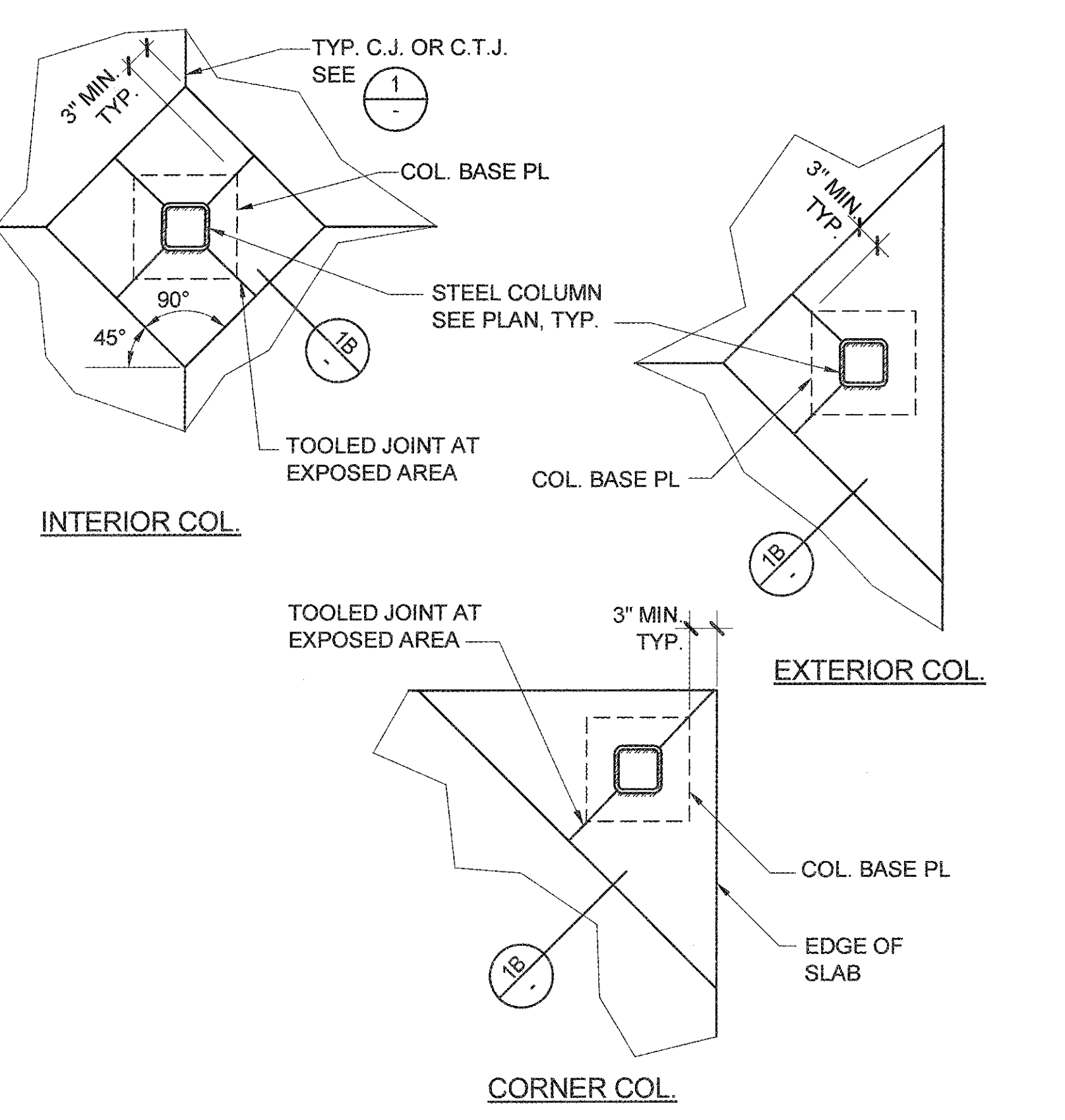

TYP. REINF. WELD SPLICE DETAIL NONE 11

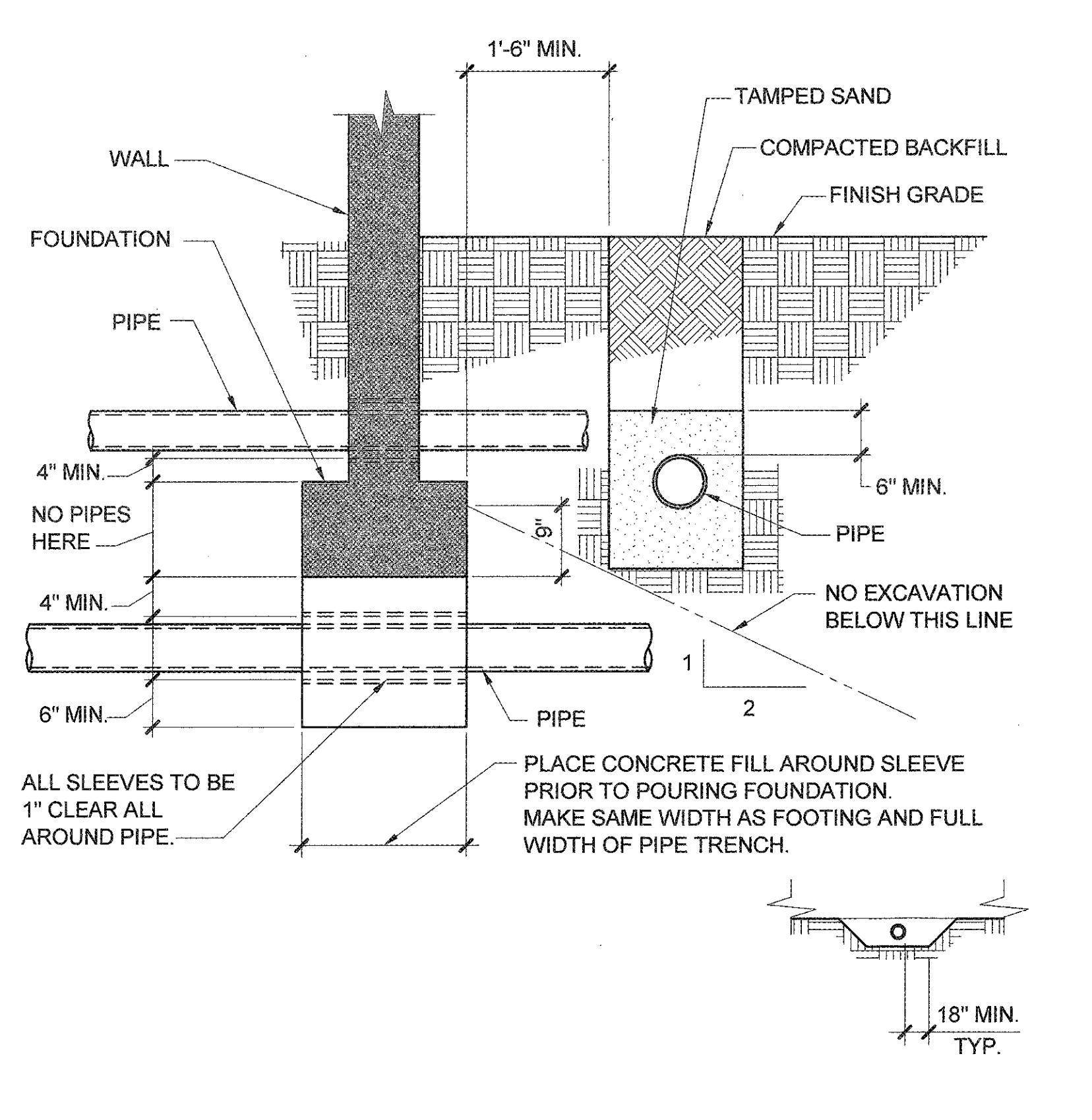

TYPICAL PIPE TRENCH DETAIL NONE 10

REBAR WELDING DETAIL 6

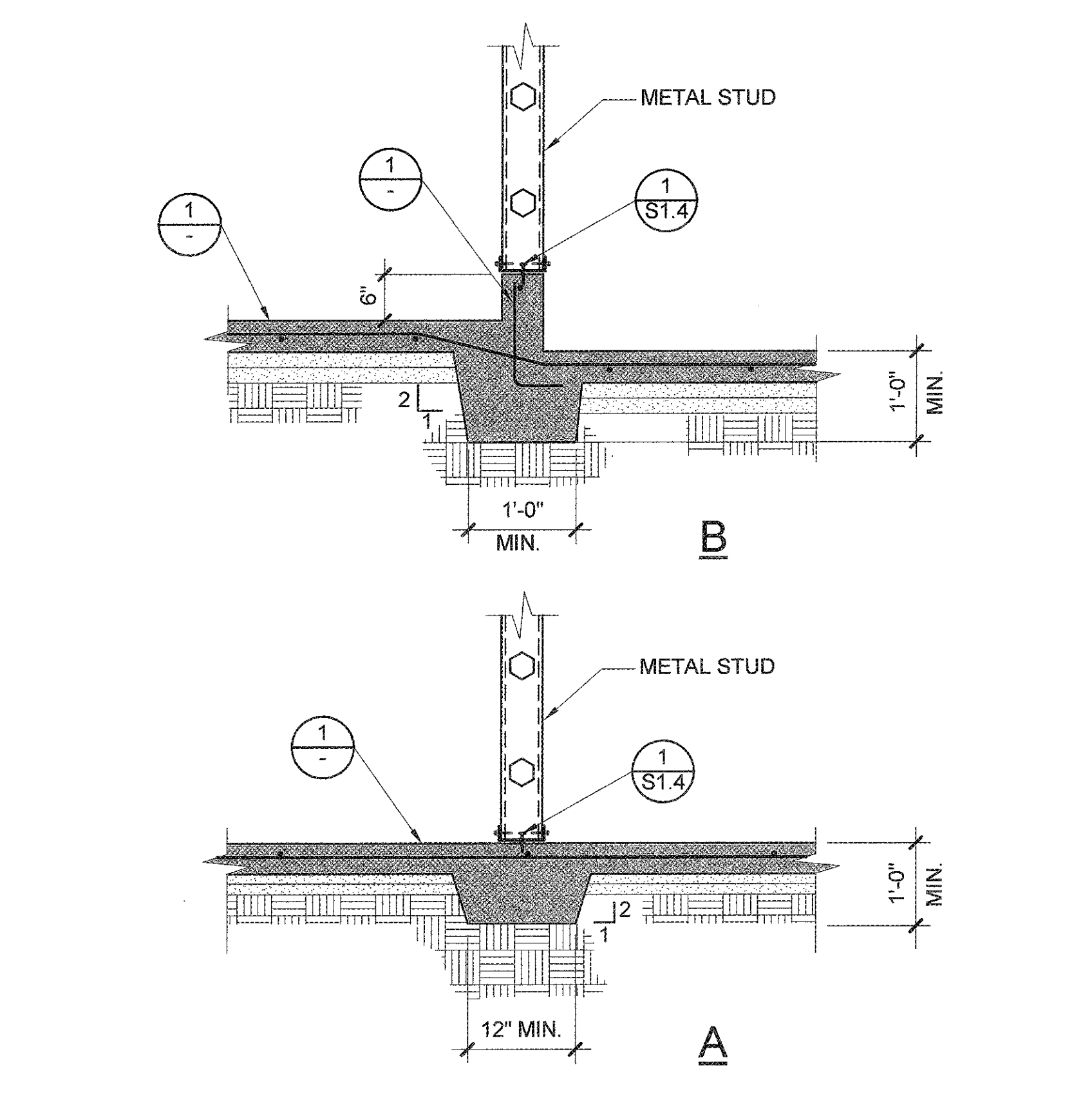

TYPICAL ISOLATION JOINT DETAIL NONE 8

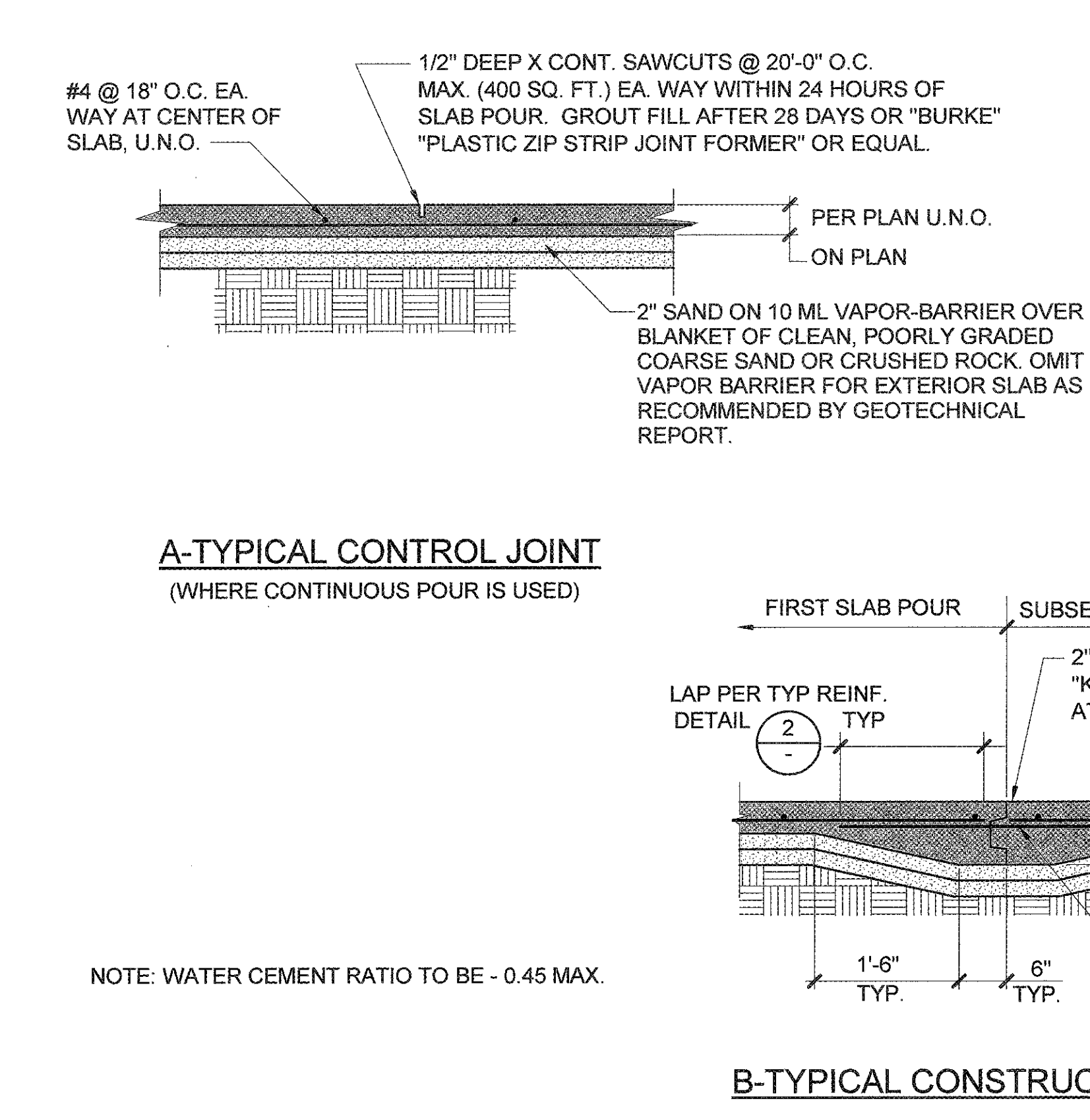

TYPICAL SLAB ON GRADE DETAILS NONE 8

TYP. MANDATORY TRENCH FORMING NONE 3

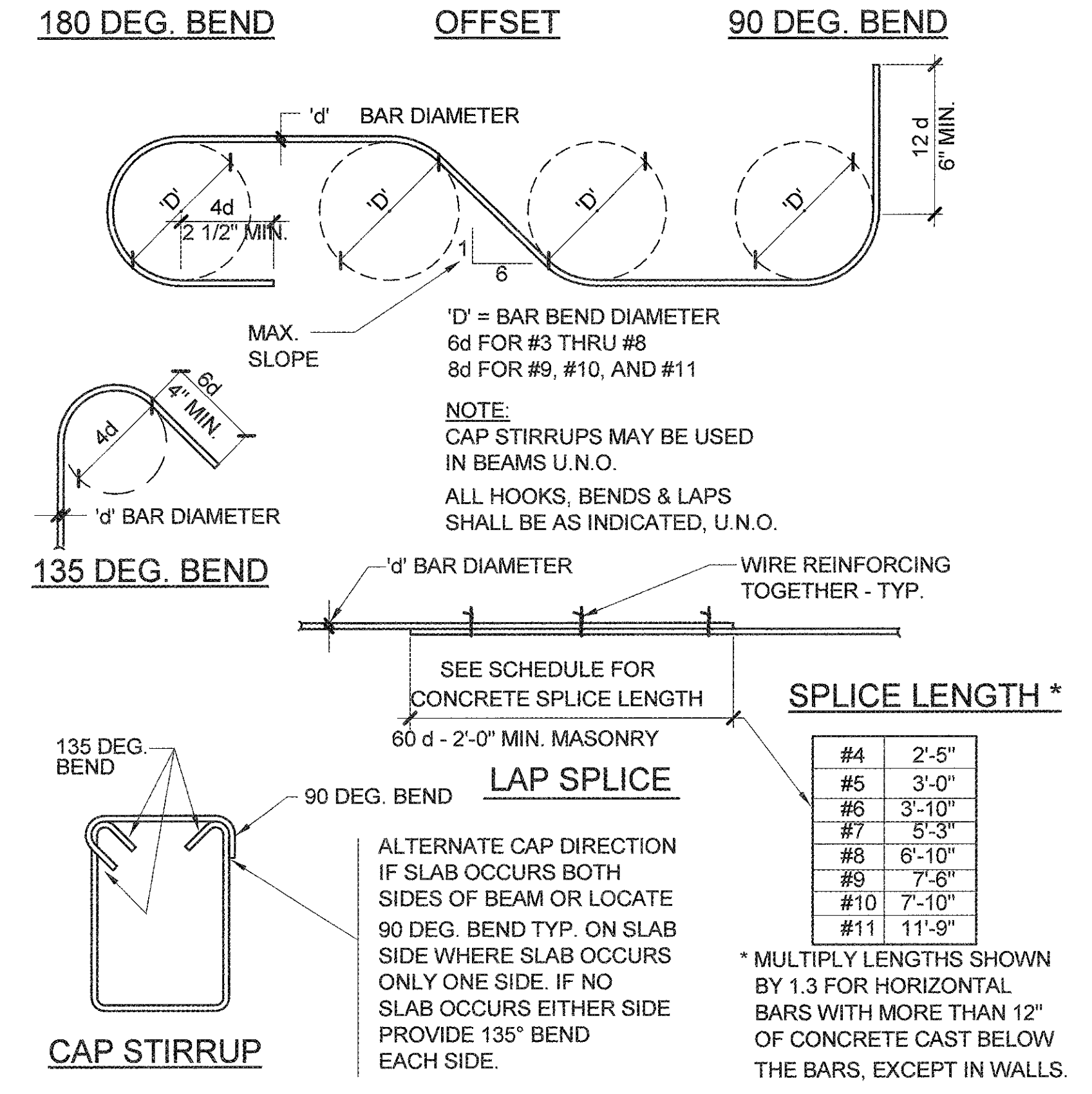

TYPICAL REINFORCING DETAILS NONE 2

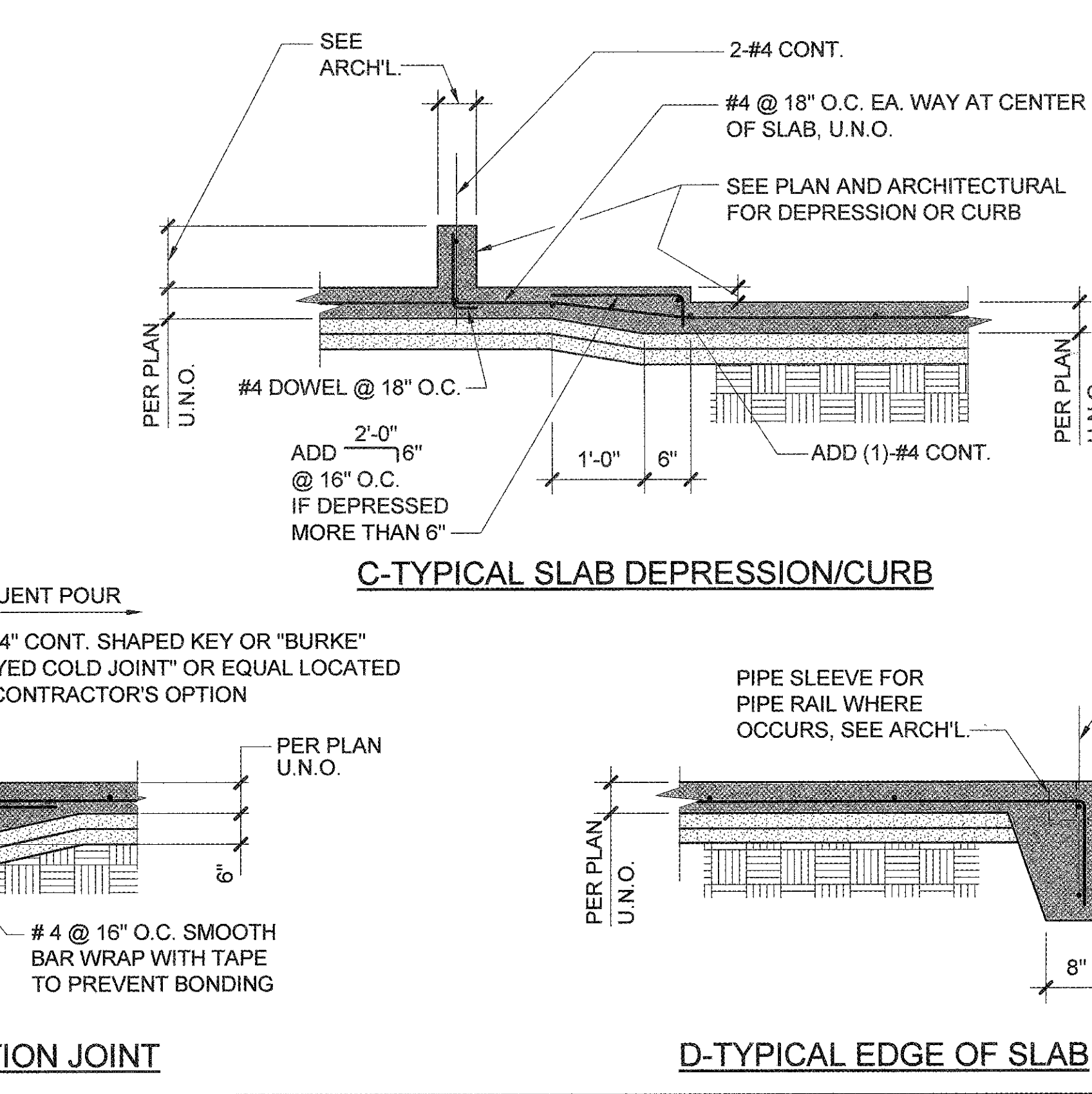

TYPICAL SLAB ON GRADE DETAILS NONE 8

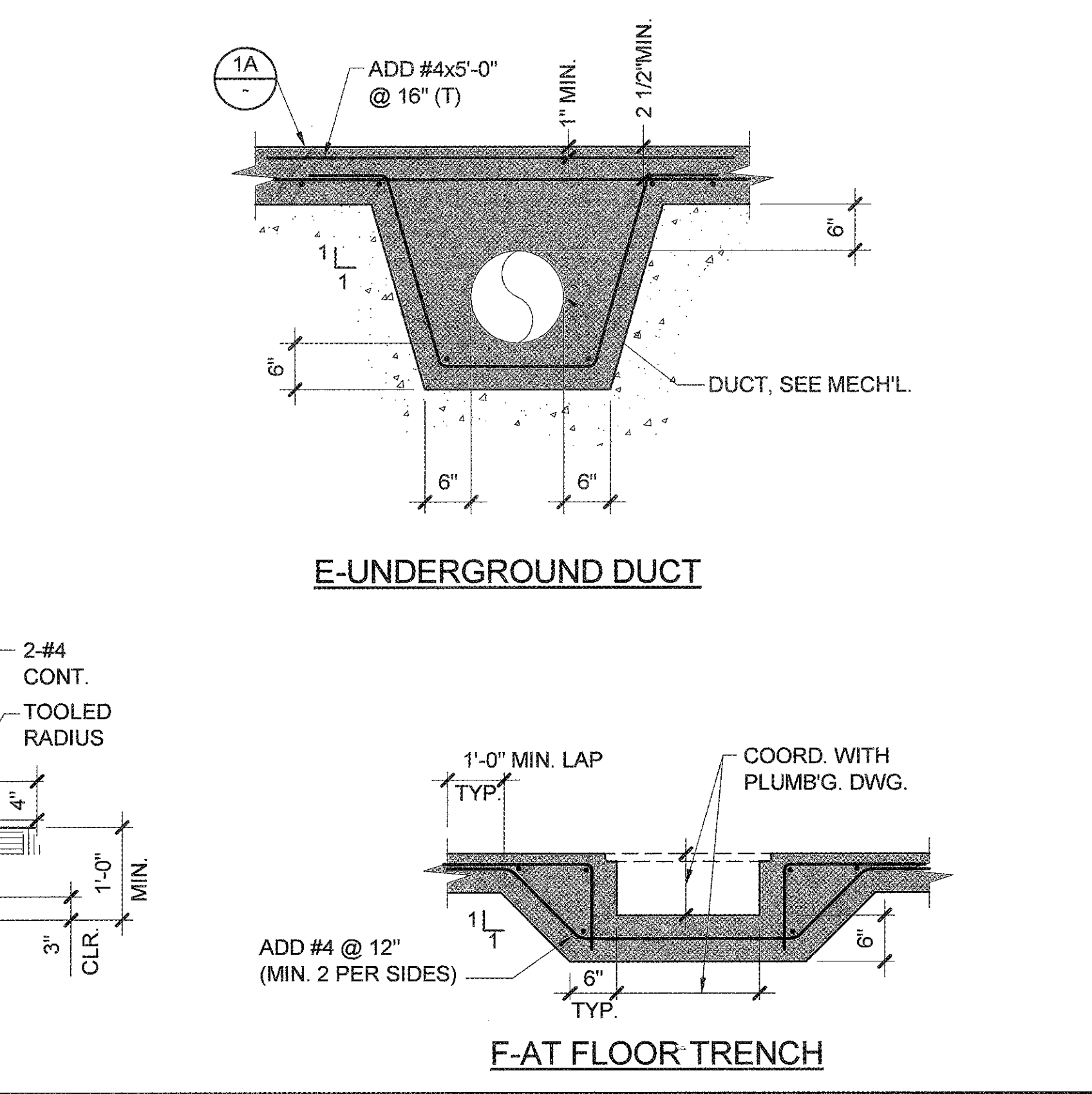

TYPICAL REINFORCING DETAILS NONE 2

LITTLE
DIVERSIFIED ARCHITECTURAL CONSULTING

1300 Dove Street, Suite 100
Newport Beach, CA 92660
T: 949.698.1400 F: 949.698.1433
www.littleonline.com

This drawing and the design shown are the property of Little Diversified Architectural Consulting. The reproduction, copying or other use of this drawing without their written consent is prohibited and any infringement will be subject to legal action.

© Little 2016

COMPTON
CCD

CAMPUS PUBLIC SAFETY BUILDING

1111 EAST ARTESIA BOULEVARD,
COMPTON CALIFORNIA 90221

IDENTIFICATION STAMP
DIV. OF THE STATE ARCHITECT
OFFICE OF REGULATION SERVICES

FILE NO: 19-C1
AR: 03-17673

DATE: DEC. 1.2.2017

TTG

901 Via Piedmonte Suite 400
Ontario, California 91764
Phone: 909.477.6915 Fax: 909.477.6916
www.ttgcorp.com Project No. 0216.4877.00

REGISTERED PROFESSIONAL ENGINEER
No. S2292
EXPIRES 12/31/2018
ARCHITECTURAL
STATE OF CALIFORNIA

PRINCIPAL IN CHARGE
RITA S. CARTER
PROJECT MANAGER

SHOJI TAKESHIMA / DAVID PHAN
DRAWN BY
GERARDO CARRANZA

NO	REASON	DATE

PROJECT NUMBER
913-4675-01

DATE
11/21/17

PROJECT NO.
S1.1

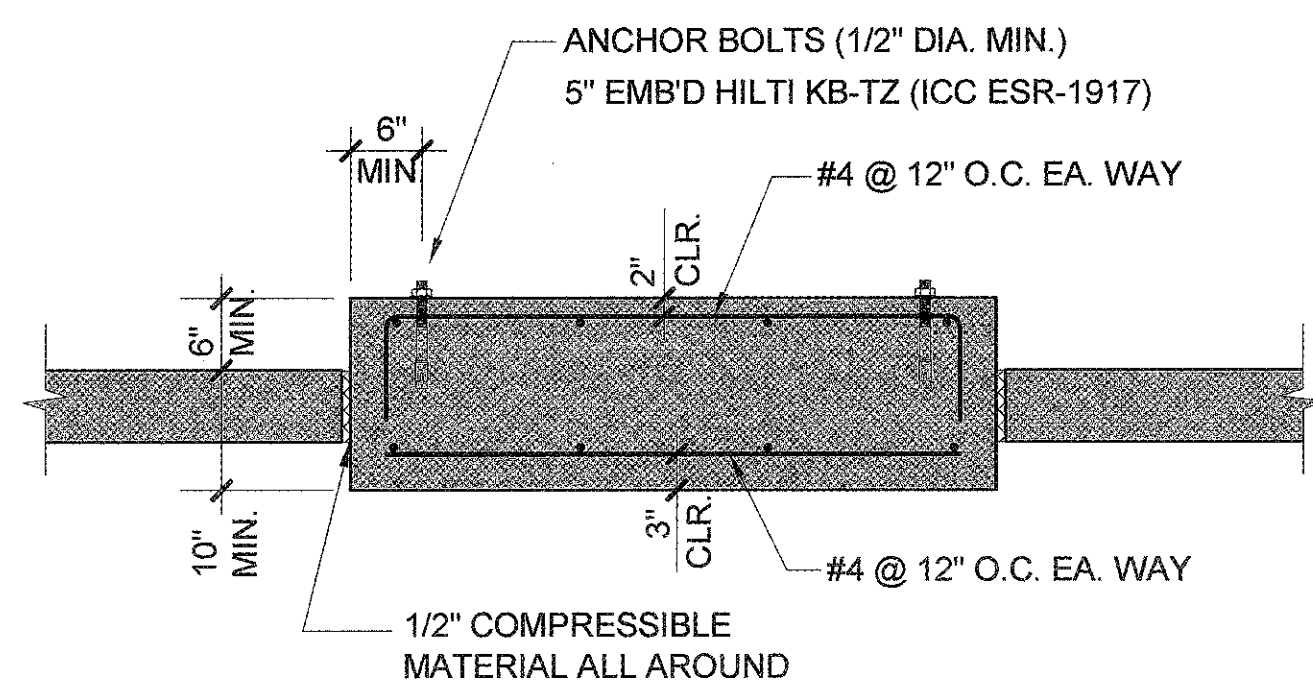

NOTES:
SEE PLUMBING, MECHANICAL, AND ELECTRICAL DWGS. FOR THE FOLLOWING:
1. LOCATION AND DIMENSIONS OF PADS.
2. LOCATION AND SIZE OF ANCHOR BOLTS
3. DETAILS OF SUPPORTS, ISOLATORS OR OTHERS.
4. EXACT LOCATION AND SIZE OF PAD WILL NOT BE SHOWN ENTIRELY ON PLANS. CONTRACTOR TO COORD. AND VERIFY WITH MECH'L., ELECT'L., KITCHEN, PLUMBING AND ARCH'L.

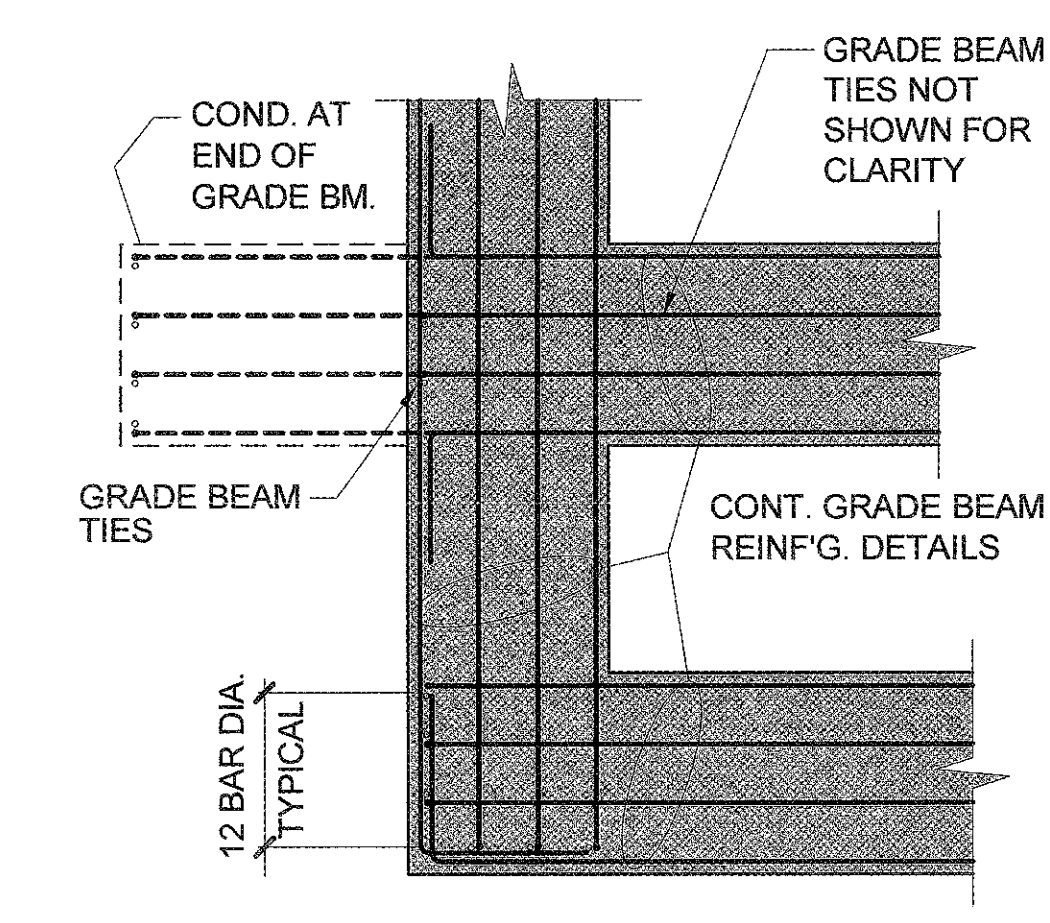
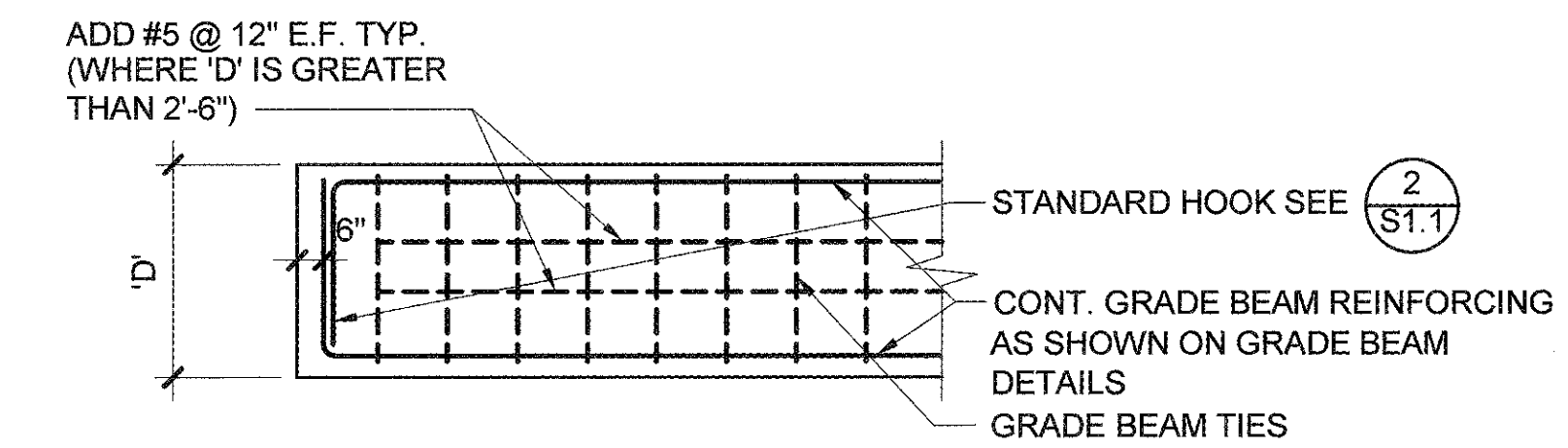

NOTE:
GRADE BEAM REINFO., TOP LAYER OF HIGH REBARS & BOTTOM LAYER OF LOW REBARS 90° BEND FOR 50% OF REBARS, REMAINDER TO BE STRAIGHT. ALTERNATE STRAIGHT BAR AND BENT BAR.

NOT USED

12

TYPICAL ISOLATION PAD DETAIL

NONE 9

NOT USED

NONE 6

TYP. GRADE BM. AND FTG. REINFORCING

NONE 3

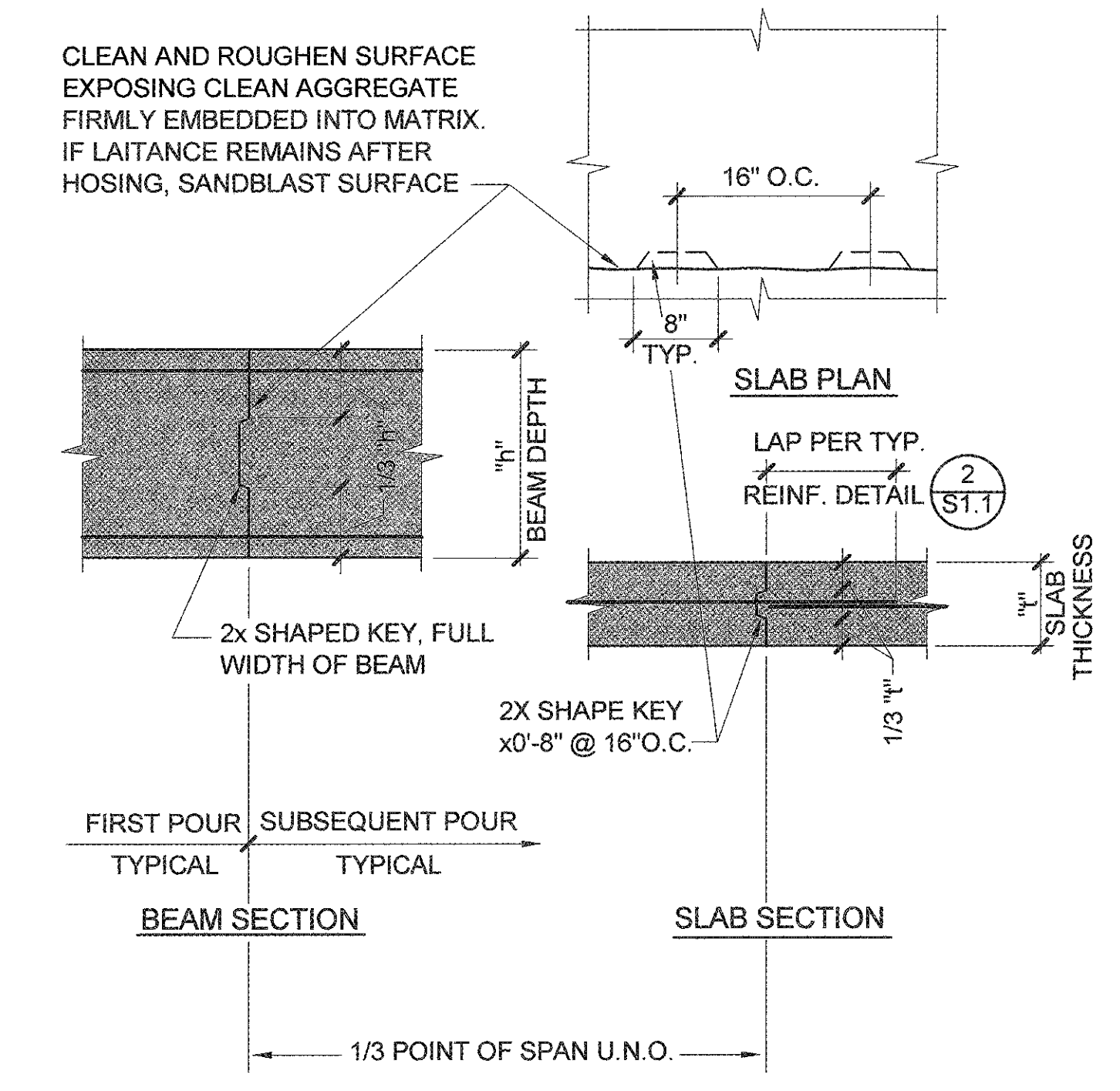
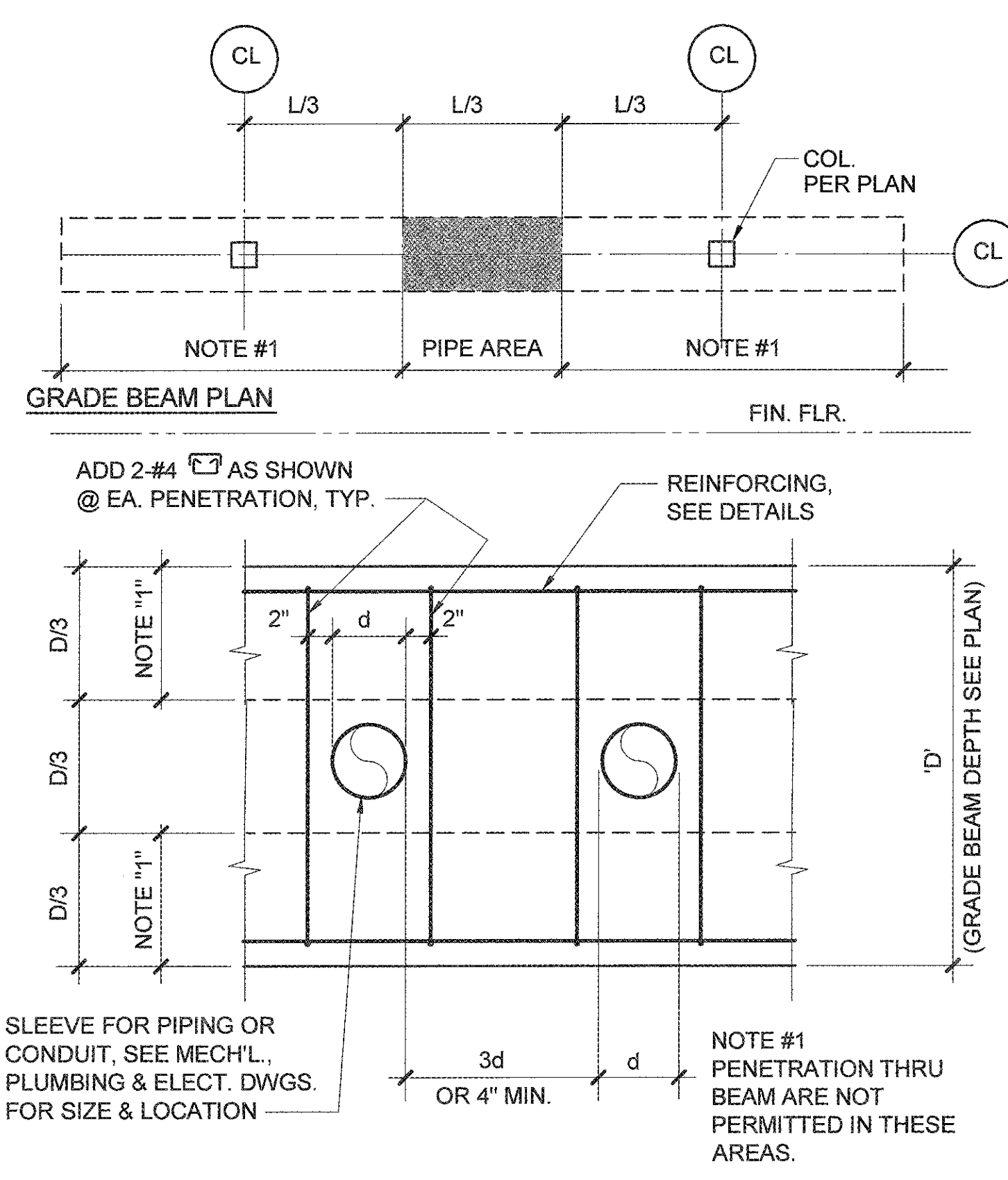
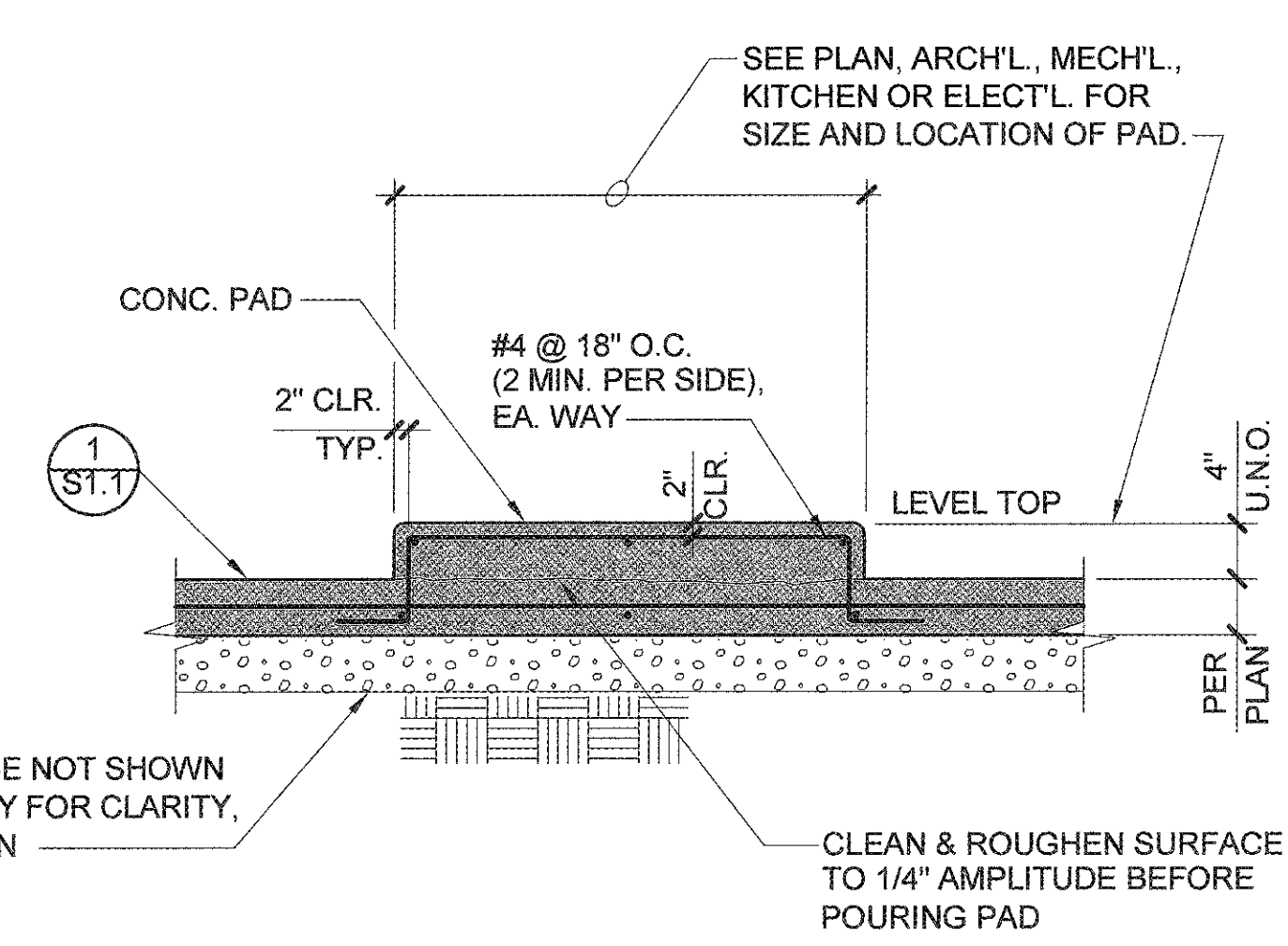

NOT USED

11

TYPICAL CONCRETE PAD DETAIL

NONE 8

PIPE AND CONDUIT THRU GRADE BEAM

NONE 5

TYP. CONST. JOINT DETAILS

NONE 2

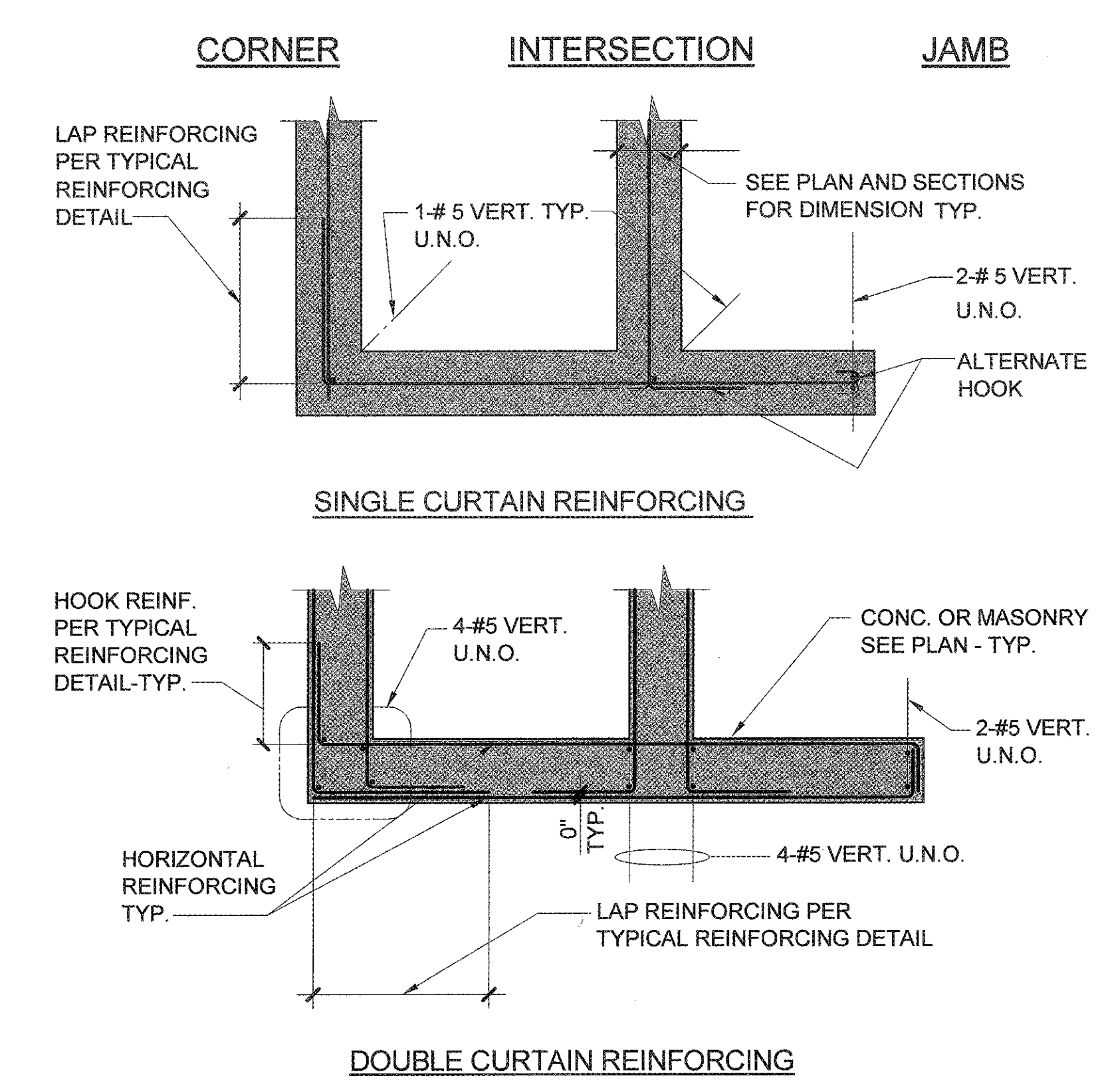
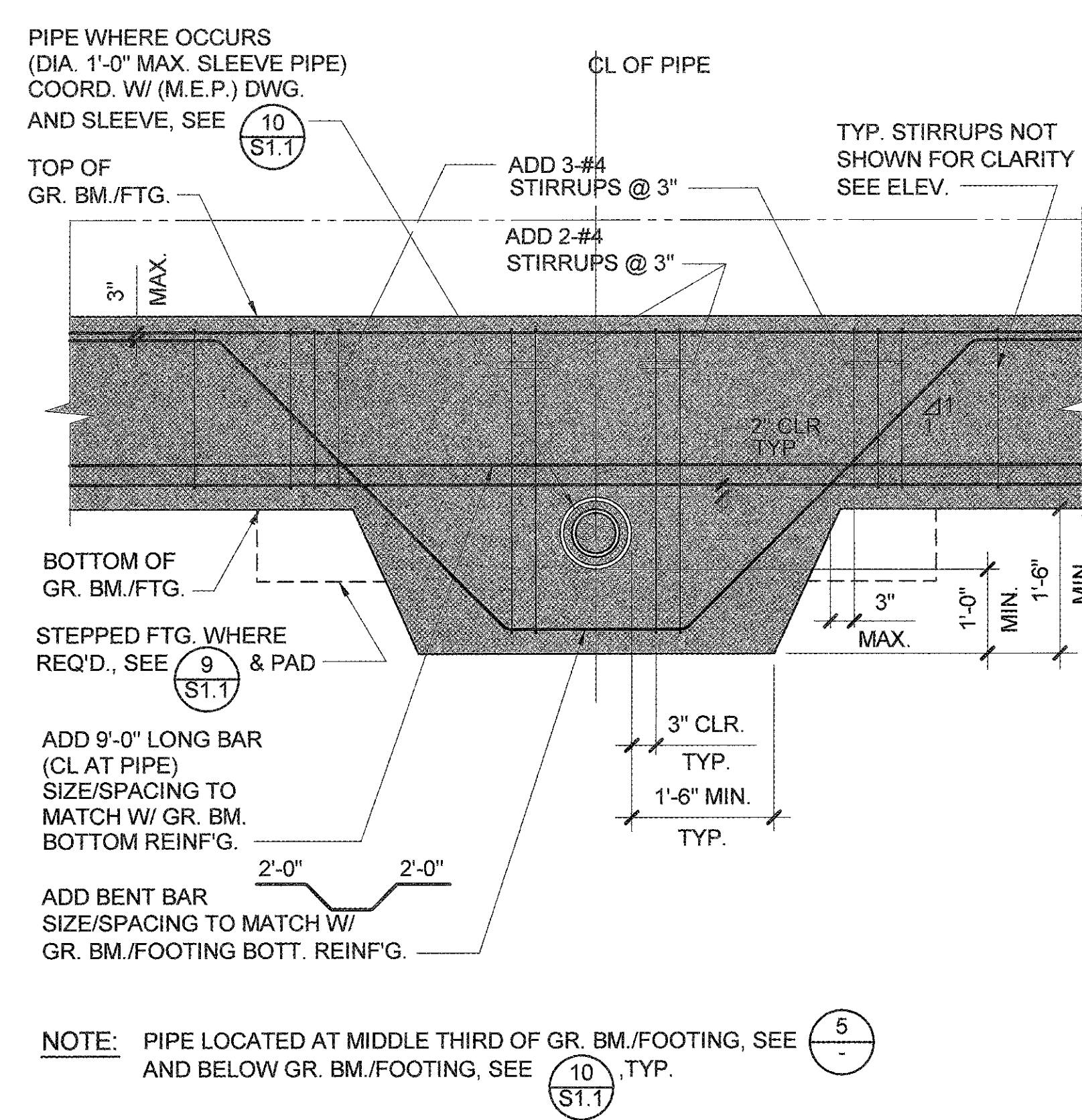
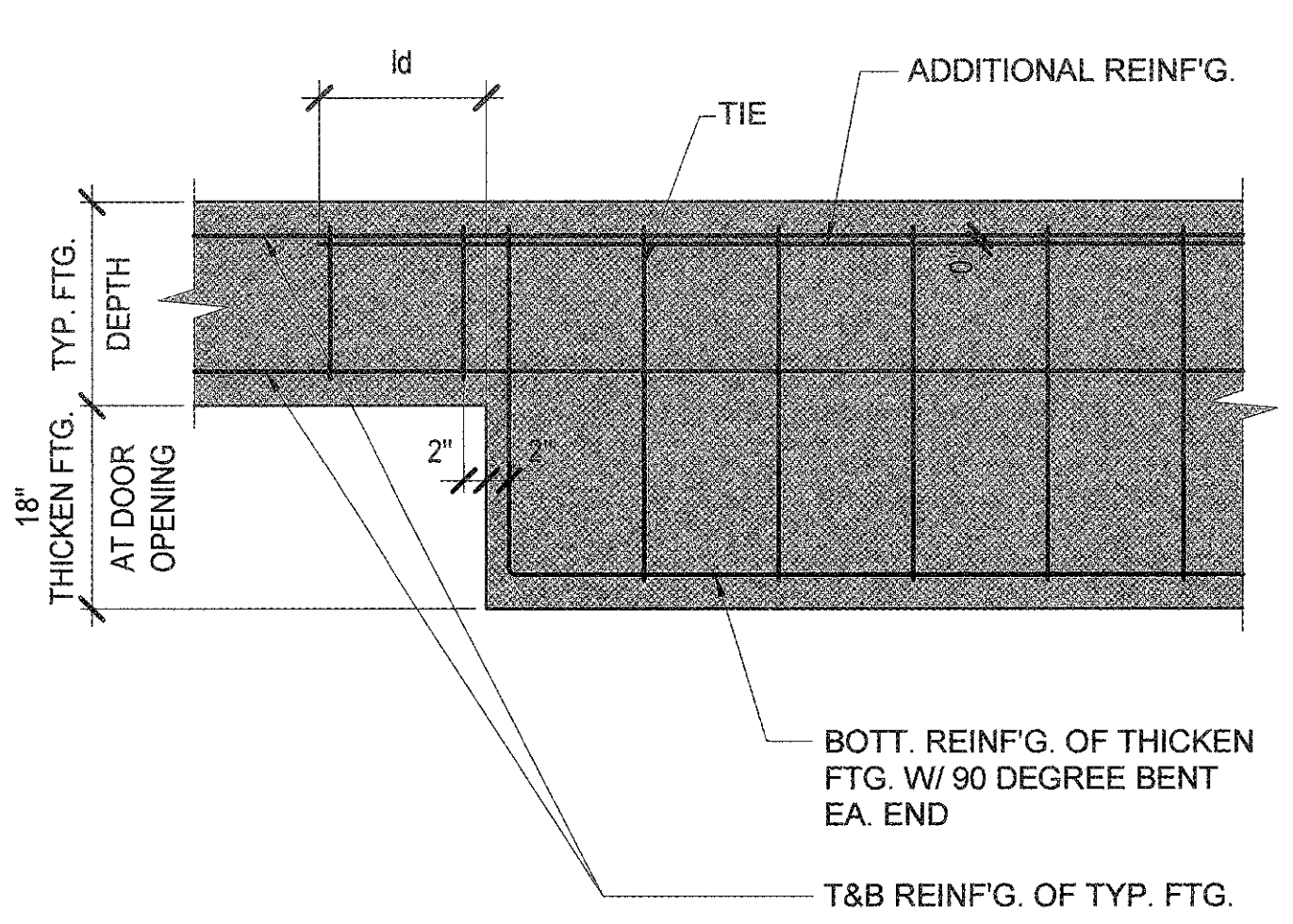

TYPICAL THICKEN FTG. ELEVATION

NONE 10

NOT USED

7

TYP. DETAIL PIPE THRU GR. BM./FTG.

NONE 4

TYP. REINFORCING INTERSECTION DET.

NONE 1

MAXIMUM SPAN FOR CEILING JOIST INTERIOR STEEL STUDS, 'S' SECTIONS				
TYPE	MILS SPACING	33	43	54
400S137	16"	7'-4"	9'-10"	
600S137	16"	11'-0"	13'-4"	16'-0"

MAXIMUM HEIGHT FOR NON-BEARING INTERIOR STEEL STUDS, 'S' SECTIONS				
TYPE	MILS SPACING	33	43	54
362S137	16"	16'-9"	18'-2"	19'-6"
400S137	16"	18'-1"	19'-8"	21'-0"
600S137	16"	24'-11"	27'-2"	29'-1"

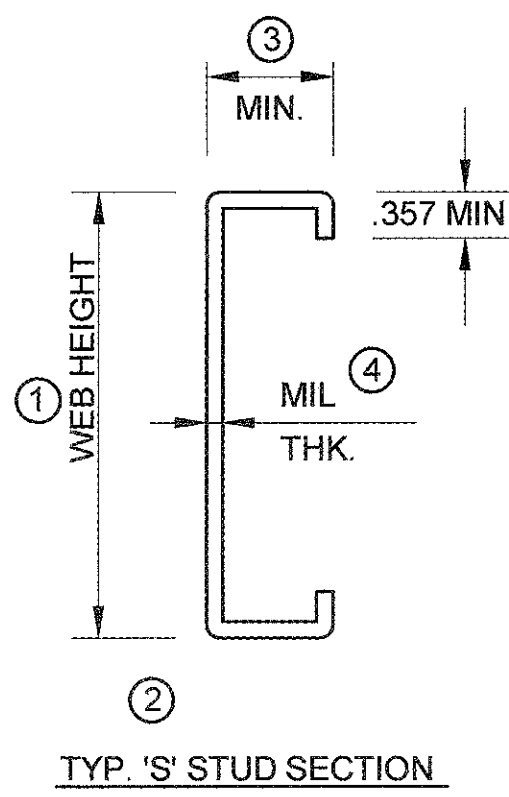

NOTES:

GENERAL:

- METAL STUDS SHALL COMPLY W/ ICC ESR-3064P METAL STUD EFFECTIVE PROPERTIES ARE: Fy=50ksi 54 MIL SECTIONS. Fy=33ksi FOR 43 AND 33 MILS SECTIONS.
- 362S137-33 SEE MANUFACTURERS CALL-OUT FOR (1) STUD DEPTH, (2) STUD STYLE, (3) FLANGE WIDTH AND (4) STUD THICKNESS

CEILING JOIST:

- ALL DBL. JOIST TO BE 54 MILS.
- TOP OF ALL CEILING JOIST SHALL BE BRACED AT 48" O.C. MAX.
- CEILING D.L. = 6 PSF L.L. = 10PSF
- PROVIDE DOUBLE JOIST ON EA. SIDE OF CEILING ACCESS OPENING TYP.

PARTITIONS:

- ALL TRACKS TO BE ONE MIL THICKER THAN STUDS OR JOIST FRAMING TO THEM UNLESS THICKER MILS REQUIRED AS NOTED BELOW OR NOTED OTHERWISE.
 - PERIMETER WALLS = 33 MILS MIN.
 - ALL STUDS SUPPORTING DBL JOIST TO BE 54 MILS.
- ALL PARTITIONS SUPPORTING ANY OF THE FOLLOWING ITEMS SHALL BE 43 MILS.
 - HUNG CABINETS.
 - FREE STANDING CABINETS AND EQUIPMENT TALLER THAN 36" SHALL BE ANCHORED TO WALL. SEE ARCHT.

TRACK SECTION PROPERTIES							
SECTION	Sx (in ³)	Ix (in ⁴)	AREA (IN ²)	SECTION	Sx (in ³)	Ix (in ⁴)	AREA (IN ²)
362T150-33	0.264	0.499	0.279	600T150-33	0.517	1.590	0.311
362T150-43	0.343	0.650	0.398	600T150-43	0.673	2.072	0.405
362T150-54	0.431	0.823	0.578	600T150-54	0.843	2.611	0.509
400T150-33	0.300	0.622	0.242	162 T150-33	0.087	0.077	0.143
400T150-43	0.390	0.811	0.315				
400T150-54	0.489	1.025	0.396				

METAL STUD SECTION PROPERTIES							
SECTION	Sxx (in ³)	Ixx (in ⁴)	AREA (IN ²)	SECTION	Sxx (in ³)	Ixx (in ⁴)	AREA (IN ²)
362S137-33	0.264	0.479	0.236	600S137-33	0.527	1.582	0.318
362S137-43	0.340	0.616	0.306	600S137-43	0.681	2.042	0.413
362S137-54	0.417	0.756	0.379	600S137-54	0.839	2.518	0.514
400S137-33	0.301	0.603	0.249	250 S137-43	0.268	0.261	0.255
400S137-43	0.388	0.776	0.303	350 S137-43	0.324	0.518	0.300
400S137-54	0.477	0.953	0.421				

CLG. JOIST, PARTITION SCHED. AND METAL 'S' STUDS SECTION PROPERTIES

NONE 9

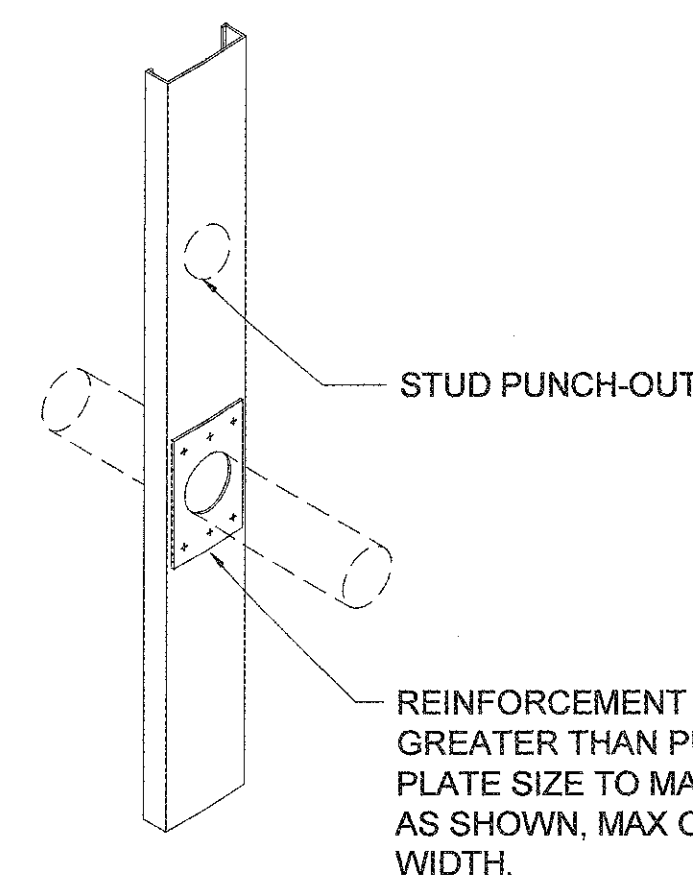

NOTES:

- FLANGES SHALL NOT BE NOTCHED OR CUT.
- PRIOR VERIFICATION BY STRUCTURAL IS REQ'D. FOR ANY OPENINGS LOCATED AT CONCENTRATED LOADS AND BEARING ENDS.
- FOR UNPUNCHED MEMBERS OBTAIN APPROVAL FROM THE ENGINEER PRIOR TO ANY FIELD PENETRATIONS.
- OPENING LARGER THAN PUNCH-OUT SHALL NOT BE PERMITTED IN MID-THIRD OF THE STUD HEIGHT.

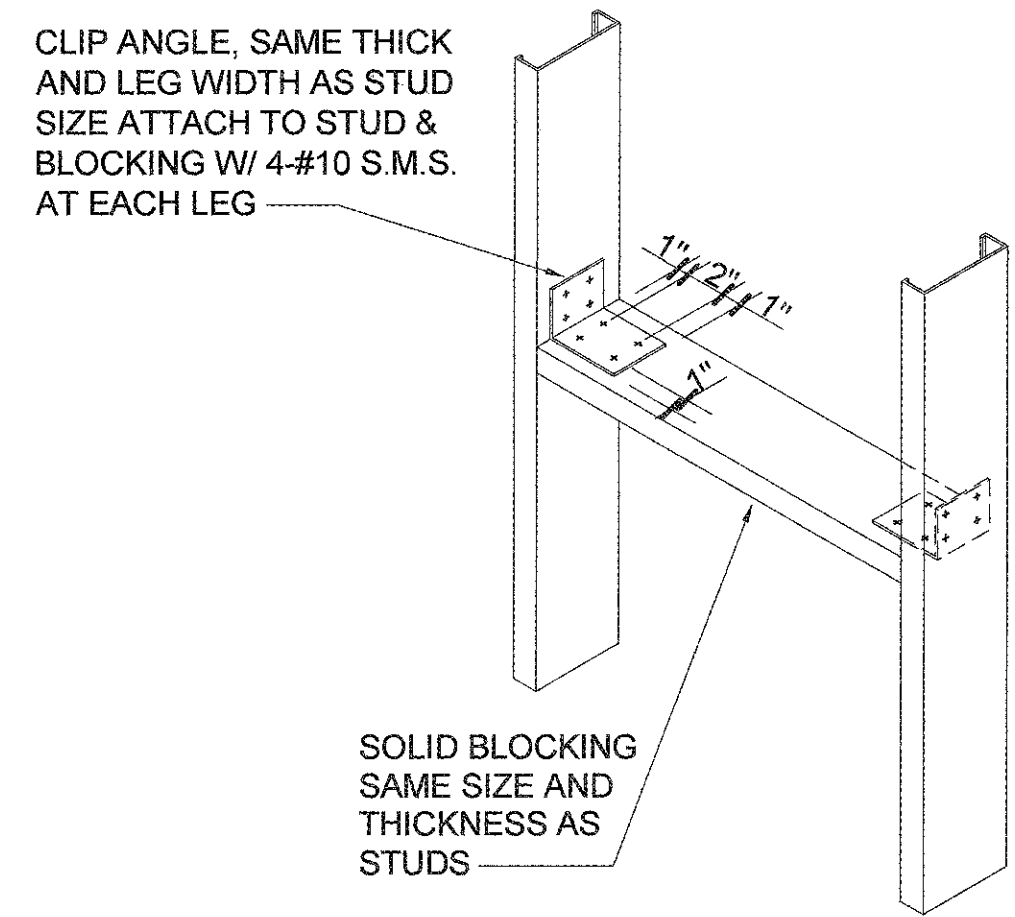

NOTES:

- WHERE BLOCKING MATERIAL THICKNESS ALLOWS, NOTCH AND BEND TRACK 90° FOR CONNECTION.
- WHERE PROVISIONS ARE PROVIDED FOR TRANSFER OF FLANGE FORCES TO SOLID BLOCKING, BLOCKING NEED NOT BE THE FULL DEPTH OF THE MEMBER.

ALLOWABLE STUD WEB PENETRATIONS

NONE 11

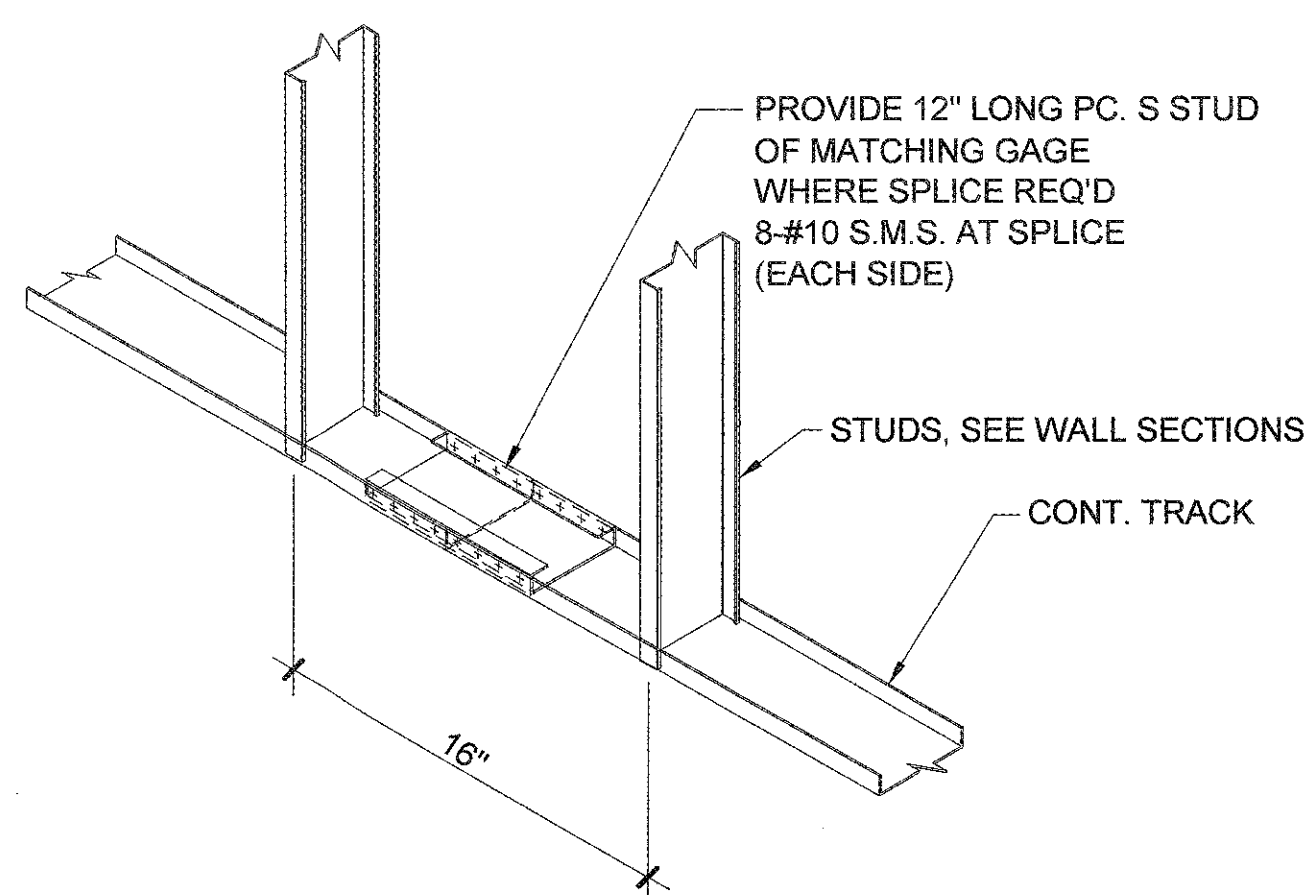

NOTE: PROVIDE SLOTTED TRACK WITH SAME GAGE AT TOP TRACK WHERE SLIP TRACK SYSTEM OCCURS.

TOP AND BOTTOM TRACK SPLICE

NONE 10

SOLID BLOCKING AT STUDS

NONE 8

NOT USED

- 7

TYP DET. AT WALL INTERSECTIONS

NONE 5

NOT USED

- 4

STEEL STUD FLANGE BRACING DETAIL

NONE 3

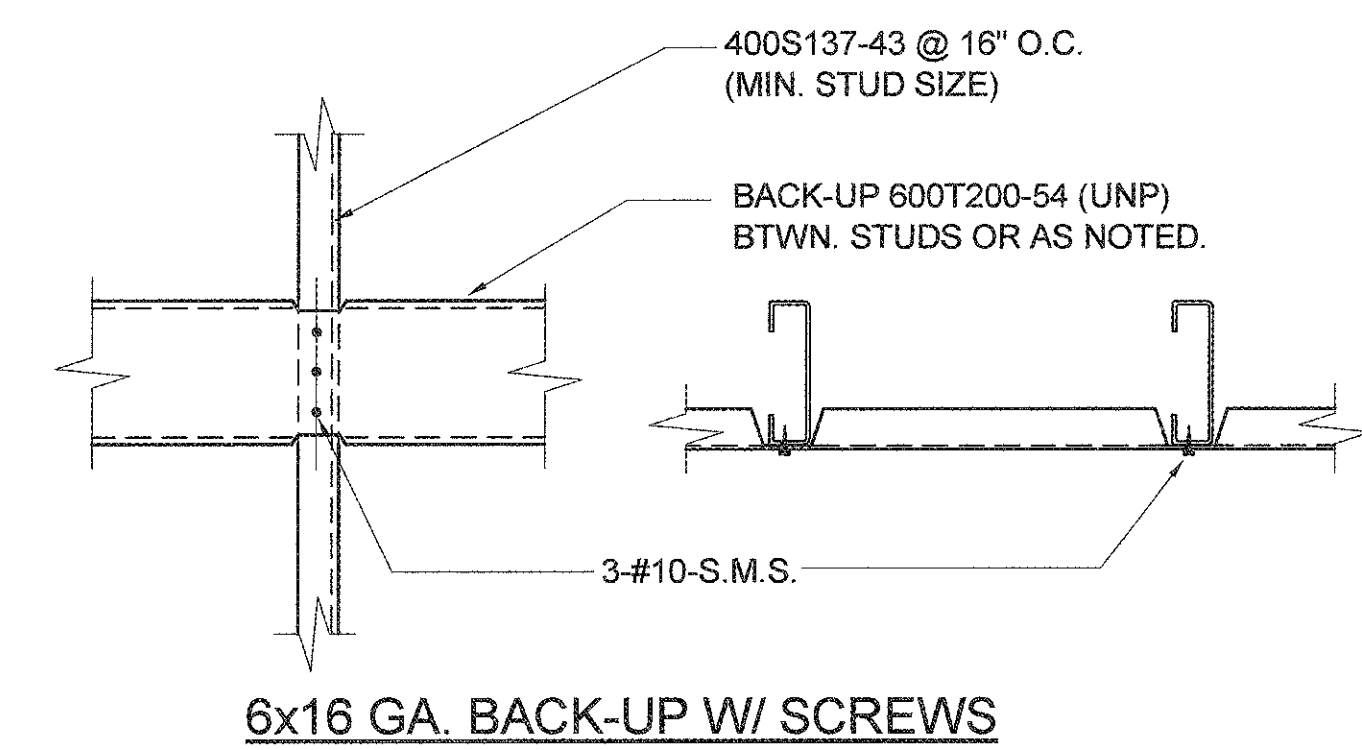
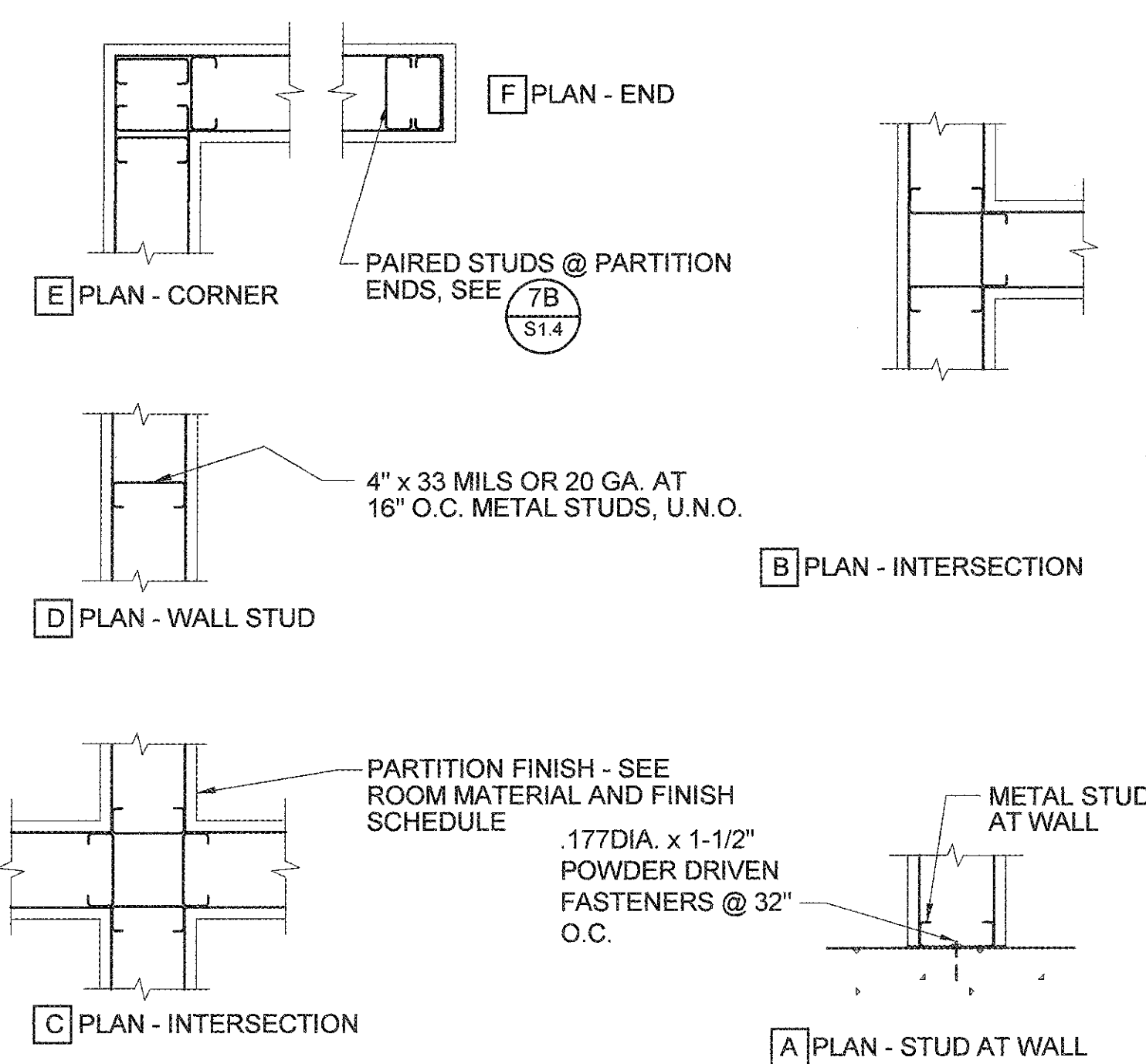

6x16 GA. BACK-UP W/ SCREWS

NOTE:

- USE THIS BRACING AT MID HEIGHT FROM FLOOR TO FLOOR, AND SPACING SHALL NOT EXCEED 4'-0" O.C.
- PROVIDE STRAP ON SIDE WITH NO FINISH MATERIAL ON WALL. IF NO FINISH ON EITHER SIDE, PROVIDE STRAP ON EACH SIDE.
- BRACING NOT REQUIRED WHERE GYP. BOARD OCCURS ON BOTH SIDES OF PARTITION WALL.

BRIDGING CHANNEL WELD-ATTACHED USING BRIDGE CLIP

BRIDGING CHANNEL SCREW-ATTACHED USING BRIDGE CLIP

OPTIONAL METHOD OF FLANGE BRACING

54 MILS x 1-1/4" STRAP W/ #8 SMS EACH STUD OR WELD W/ 1/8 x 1/2 FILLET WELD EA. SIDE

PROVIDE BLKG. SAME GA. AS STUD @ 8'-0". IF STRAP IS USED, BLKG. MUST BE AT EACH END. COPE FLANGES, BEND WEB AND USE 2-#8 TEK SCREWS OR WELD W/ 1/8 x 1/2 FILLET WELD E.S.

4-#8 SCREWS OR 4-1/8 x 3/4 FILLET WELDS EACH SIDE OF STRAP TO BLOCKING

DIV. OF THE STATE ARCHITECT
OFFICE OF REGULATION SERVICES

FILE NO: 19-C1
AR: 03-117673

AC: _____ FL: _____ SS: _____
DATE: DEC 12 2017

TTG • STRUCTURAL • MECHANICAL • ELECTRICAL • CIVIL

901 Via Placentia Suite 400
Ontario, California 91764
Phone: 909.477.8915 Fax: 909.477.8916
www.ttgcorp.com Project No. 0216.4877.00

REGISTERED PROFESSIONAL ENGINEER
No. S22992
No. 953093
ARCHITECTURAL
STATE OF CALIFORNIA

PRINCIPAL IN CHARGE

RITA S. CARTER
PROJECT MANAGER

SHOJI TAKESHIMA / DAVID PHAN
DRAWN BY

GERARDO CARRANZA

NO REASON DATE

NO REASON DATE

NO REASON DATE

NO REASON DATE

NO REASON DATE

NO REASON DATE

NO REASON DATE

NO REASON DATE

NO REASON DATE

NO REASON DATE

NO REASON DATE

NO REASON DATE

NO REASON DATE

NO REASON DATE

NO REASON DATE

NO REASON DATE

NO REASON DATE

NO REASON DATE

NO REASON DATE

NO REASON DATE

NO REASON DATE

NO REASON DATE

NO REASON DATE

NO REASON DATE

NO REASON DATE

NO REASON DATE

NO REASON DATE

NO REASON DATE

NO REASON DATE

NO REASON DATE

NO REASON DATE

NO REASON DATE

NO REASON DATE

913-4675-01

11/21/17 S1.3

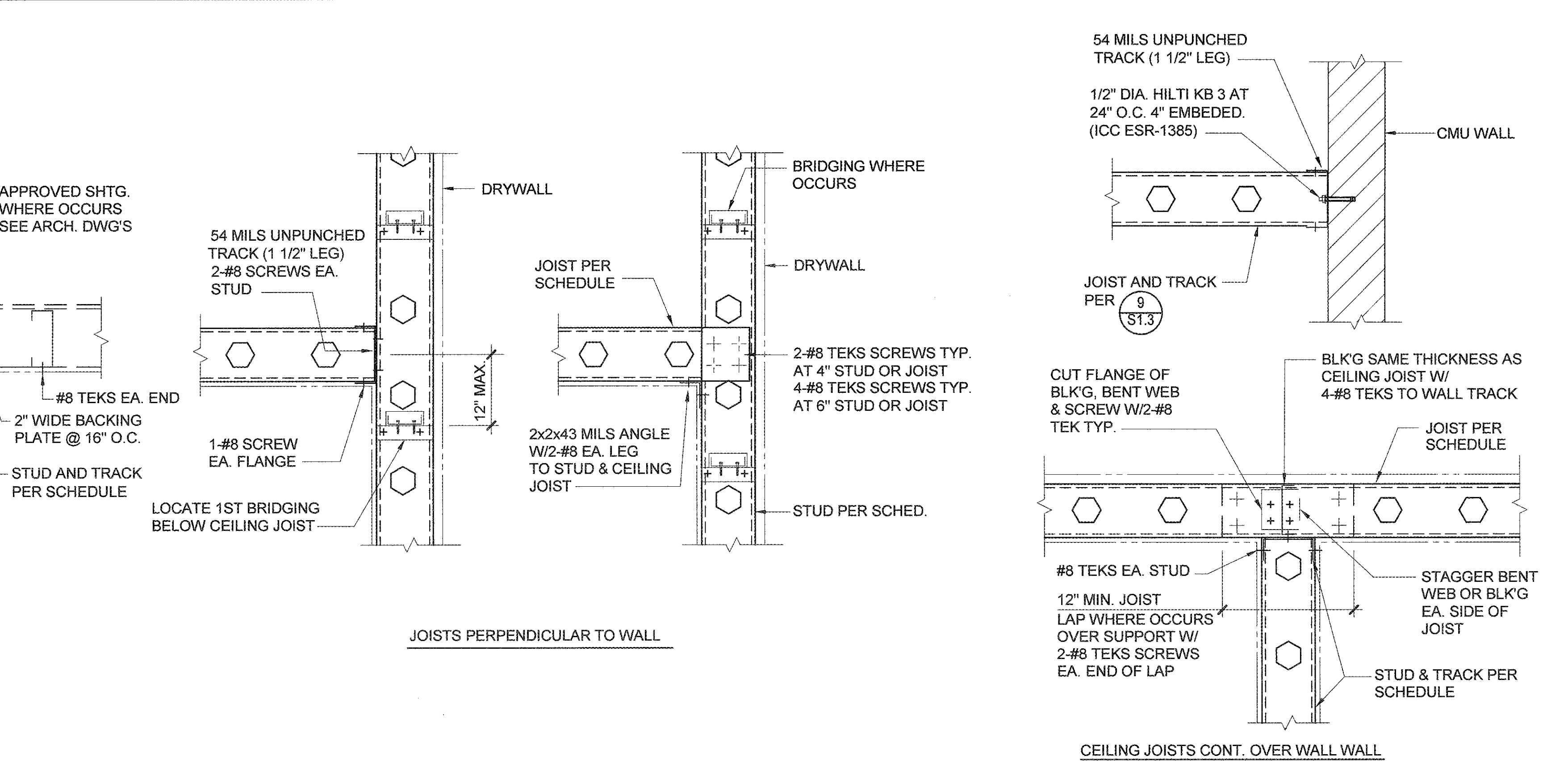
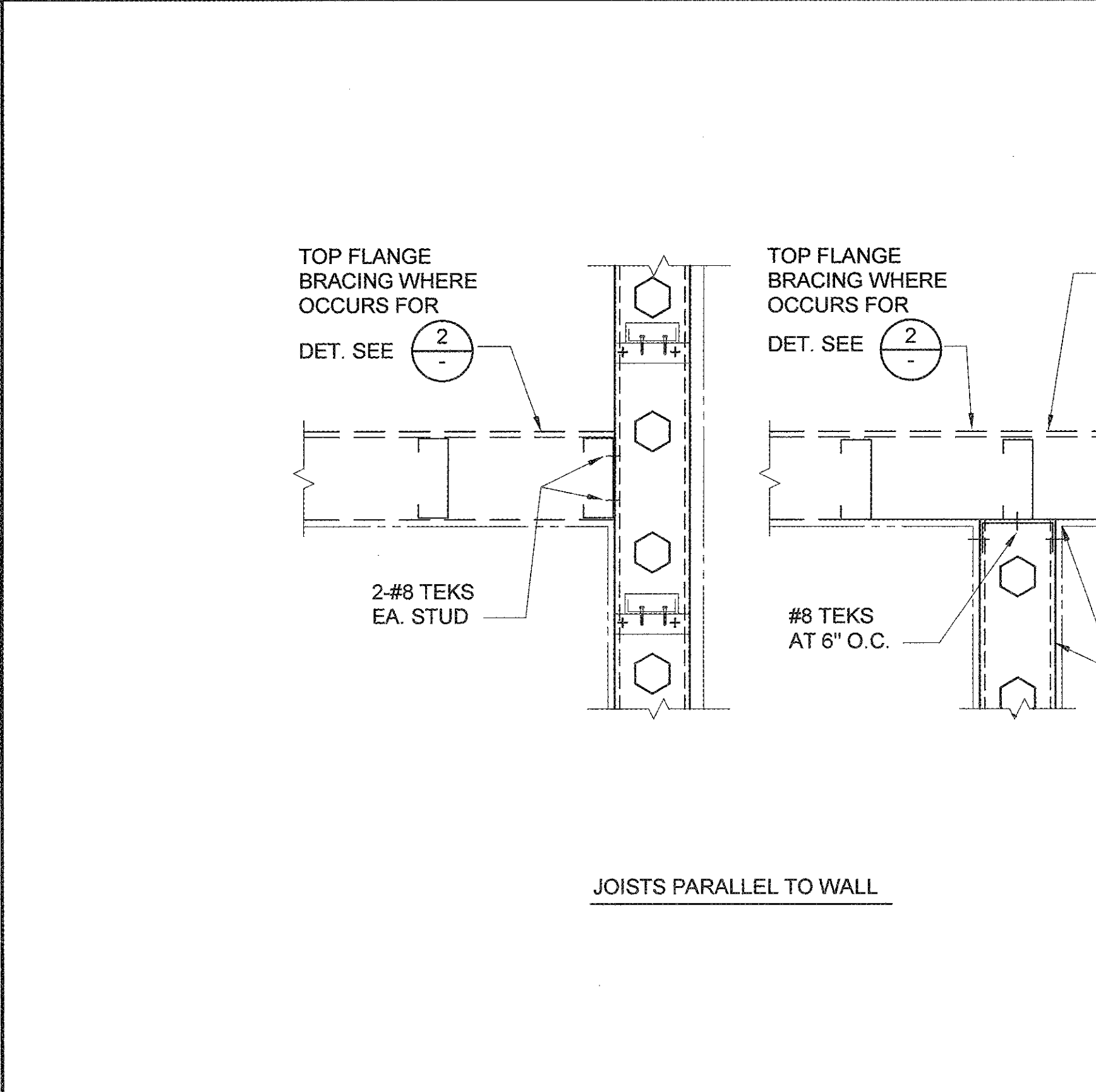
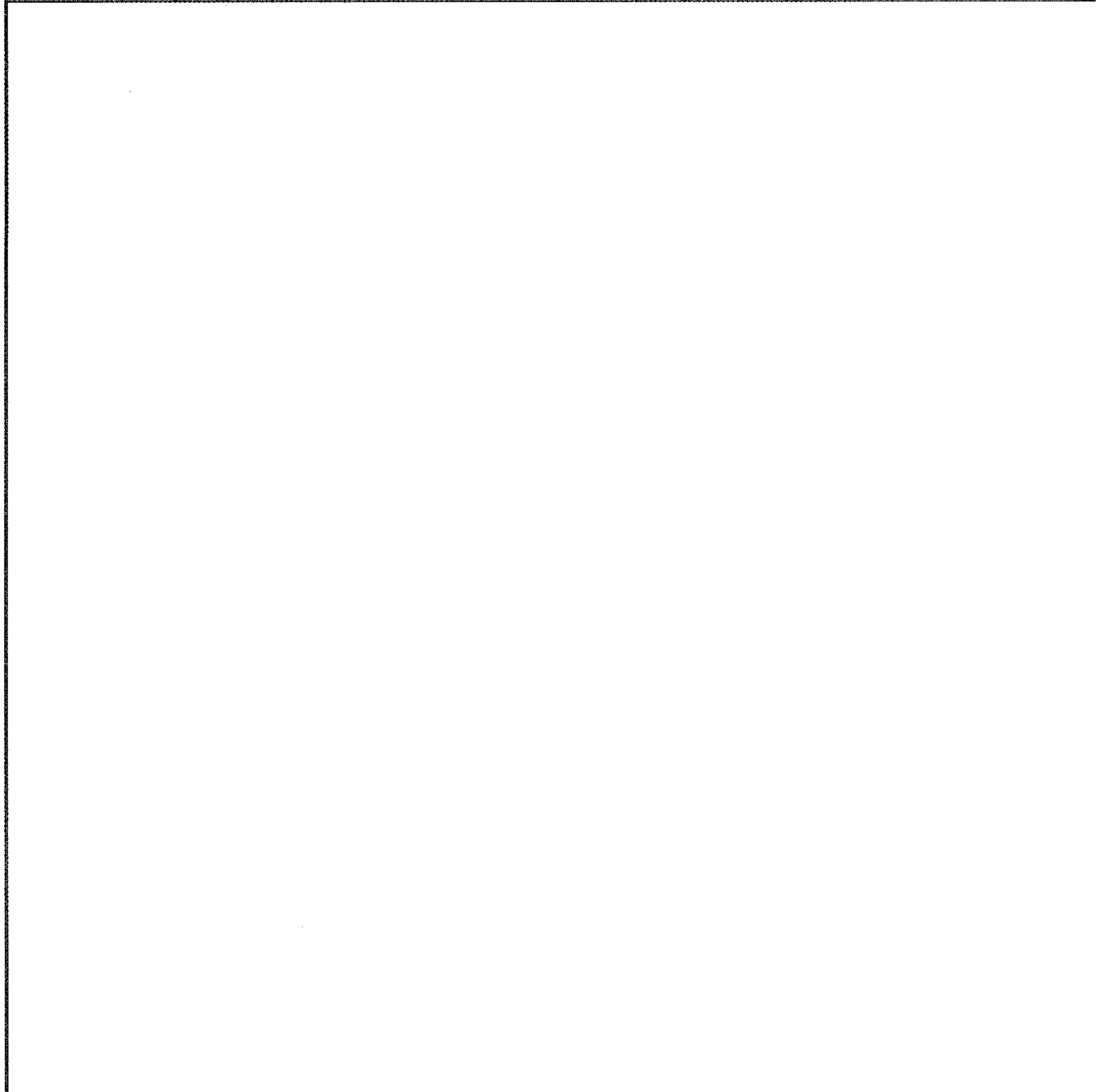

NOT USED

12

CEILING JOIST AT STUD WALL CONNECTION

NONE 3

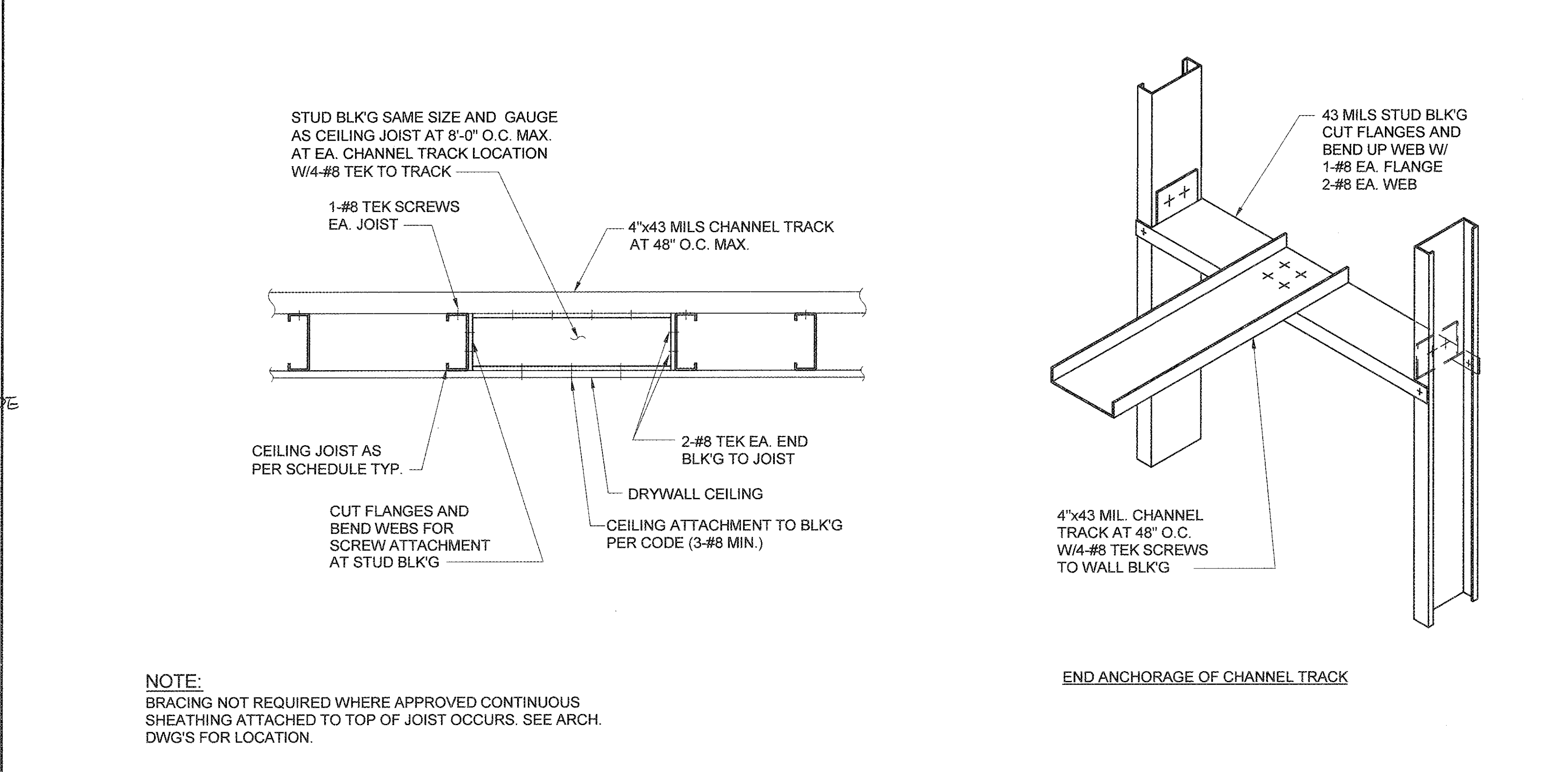
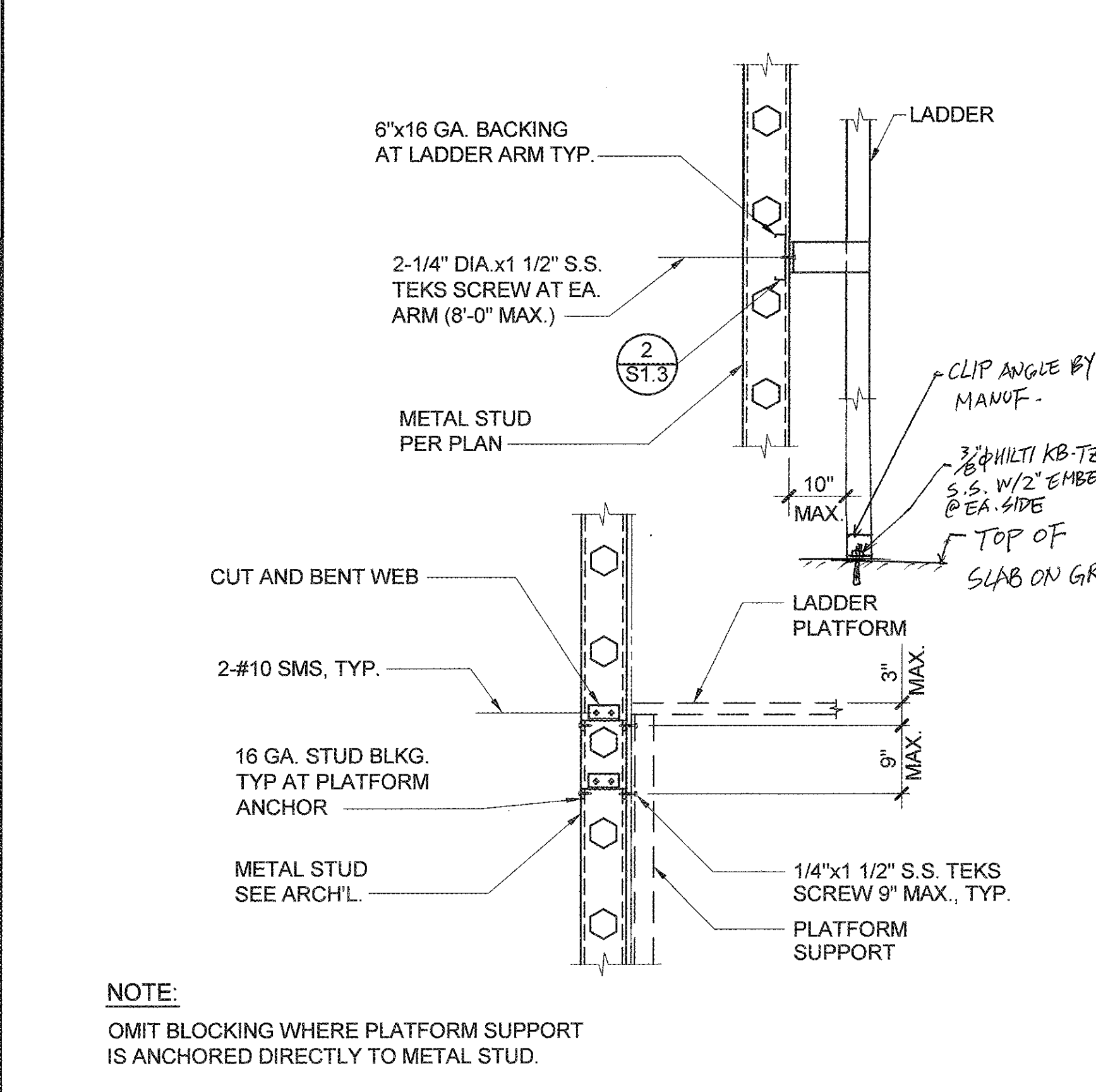
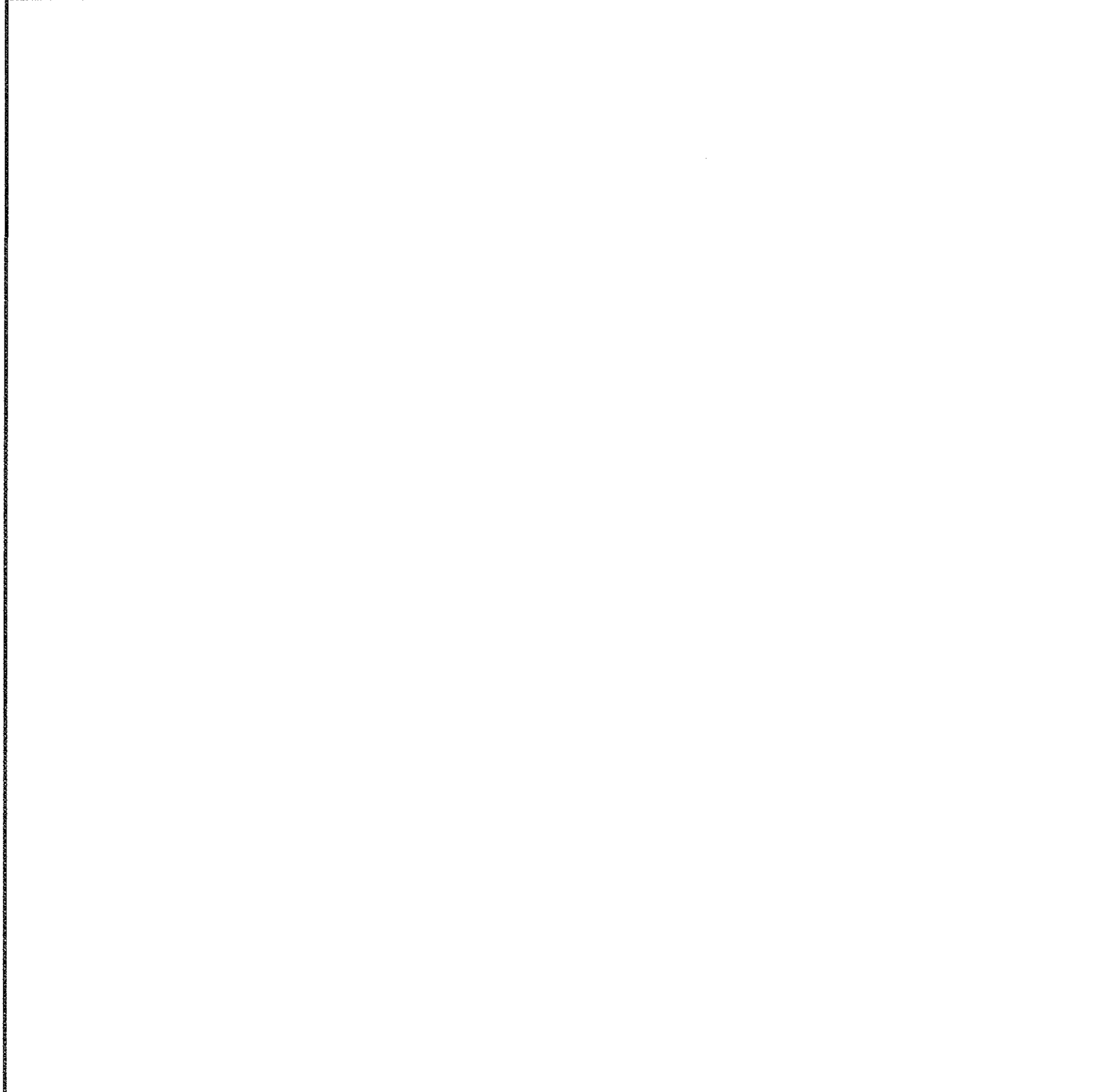

NOT USED

11

LADDER TO STUD CONNECTION DET.

NONE 8

TYP. CEILING JST BRACING & ANCHOR AT STUD WALL

NONE 2

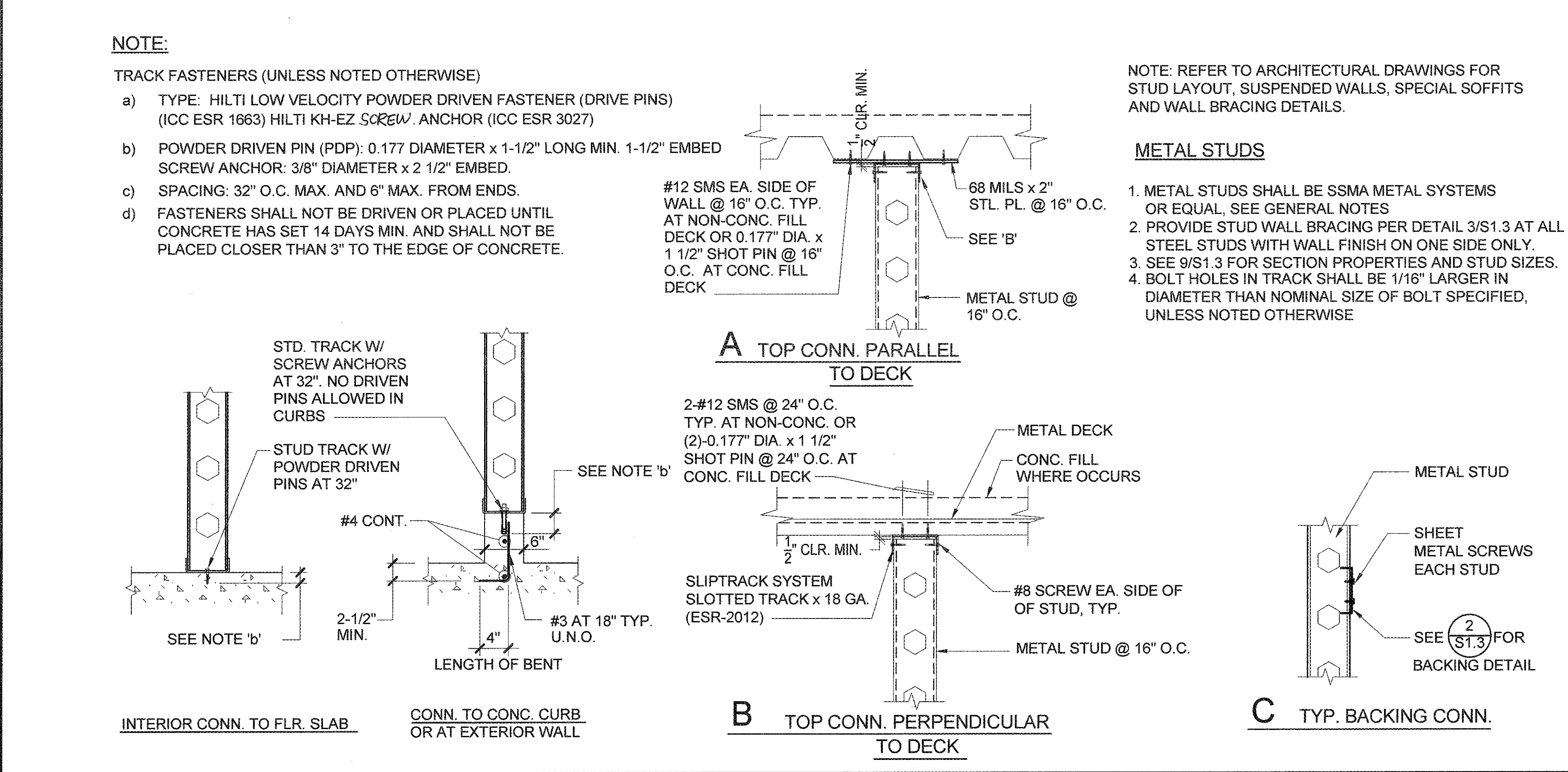
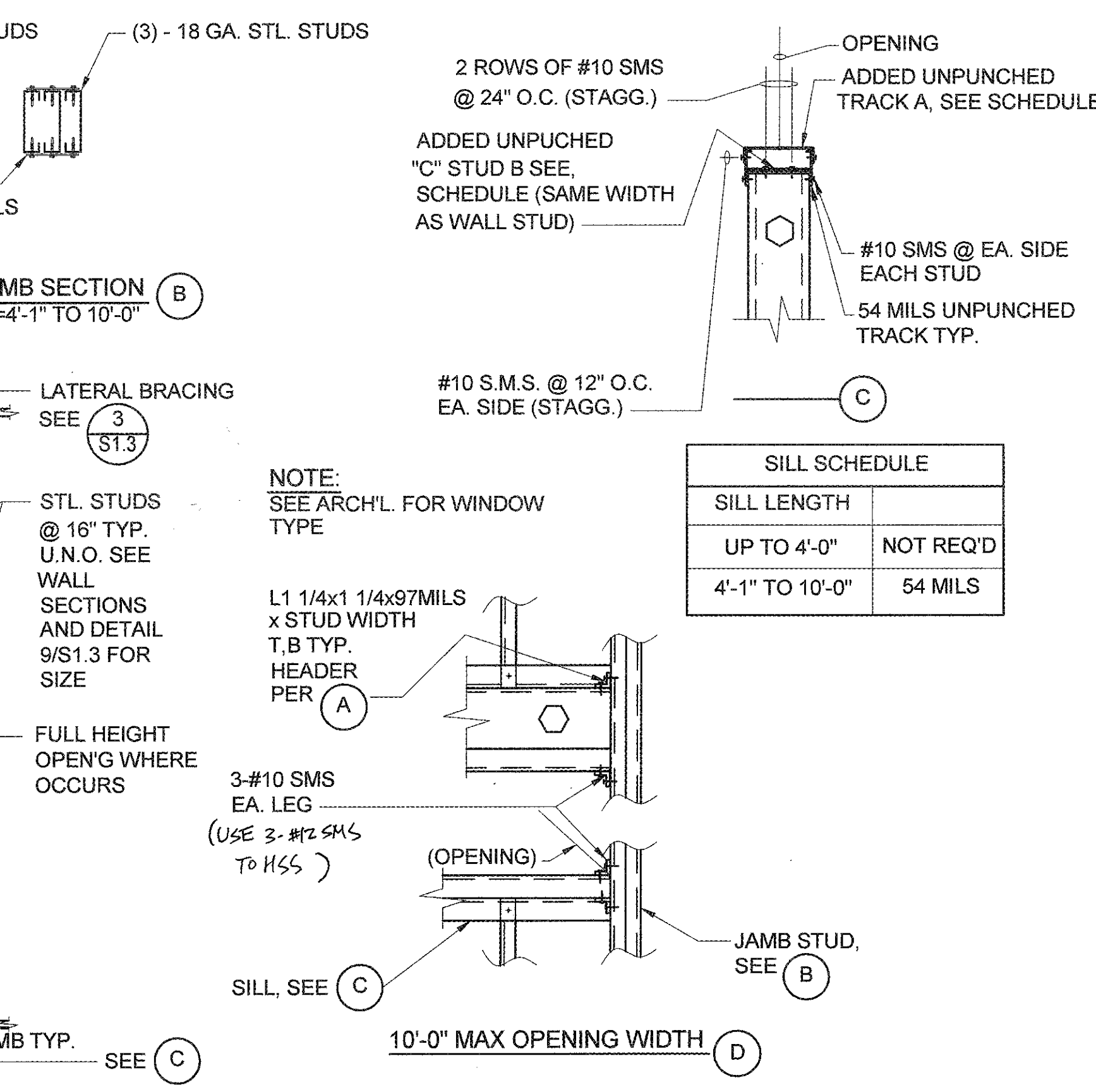
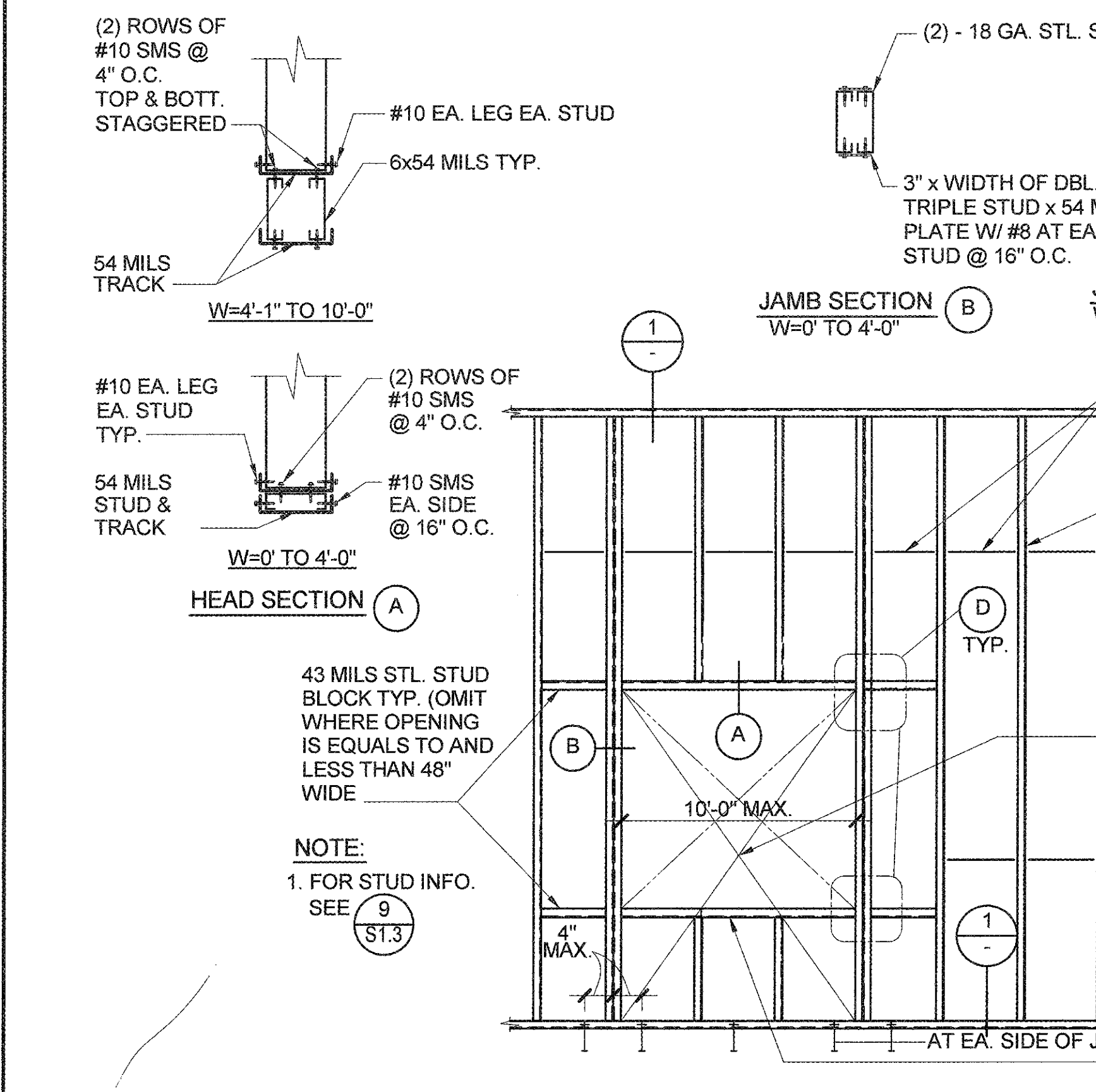

TYP. INTERIOR NON-BEARING WALL FRAMING DETAIL

NONE 7

FLOOR AND ROOF CONNECTION

NONE 1

IDENTIFICATION STAMP
DIV. OF THE STATE ARCHITECT
OFFICE OF REGULATION SERVICES
FILE NO. 19-C1
AR. 03-117673
AC R/S SS
DATE DEC 12 2017

TTG
STRUCTURAL
MECHANICAL
ELECTRICAL
CIVIL
901 Via Piemonte Suite 400
Ontario, California 91764
Phone: 909.477.6915 Fax: 909.477.8916
www.ttgcorp.com Project No. 0216.4877.00

REGISTERED PROFESSIONAL ENGINEER
TERRY C. TSANG
No. 52992
STRUCTURAL
STATE OF CALIFORNIA

PRINCIPAL IN CHARGE
RITA S. CARTER
PROJECT MANAGER
SHOJI TAKEISHIMA / DAVID PHAN
DRAWN BY
GERARDO CARRANZA

NO	REASON	DATE

TYPICAL DETAILS

PROJECT NUMBER
913-4675-01

DATE
11/21/17
SCALE
S1.4

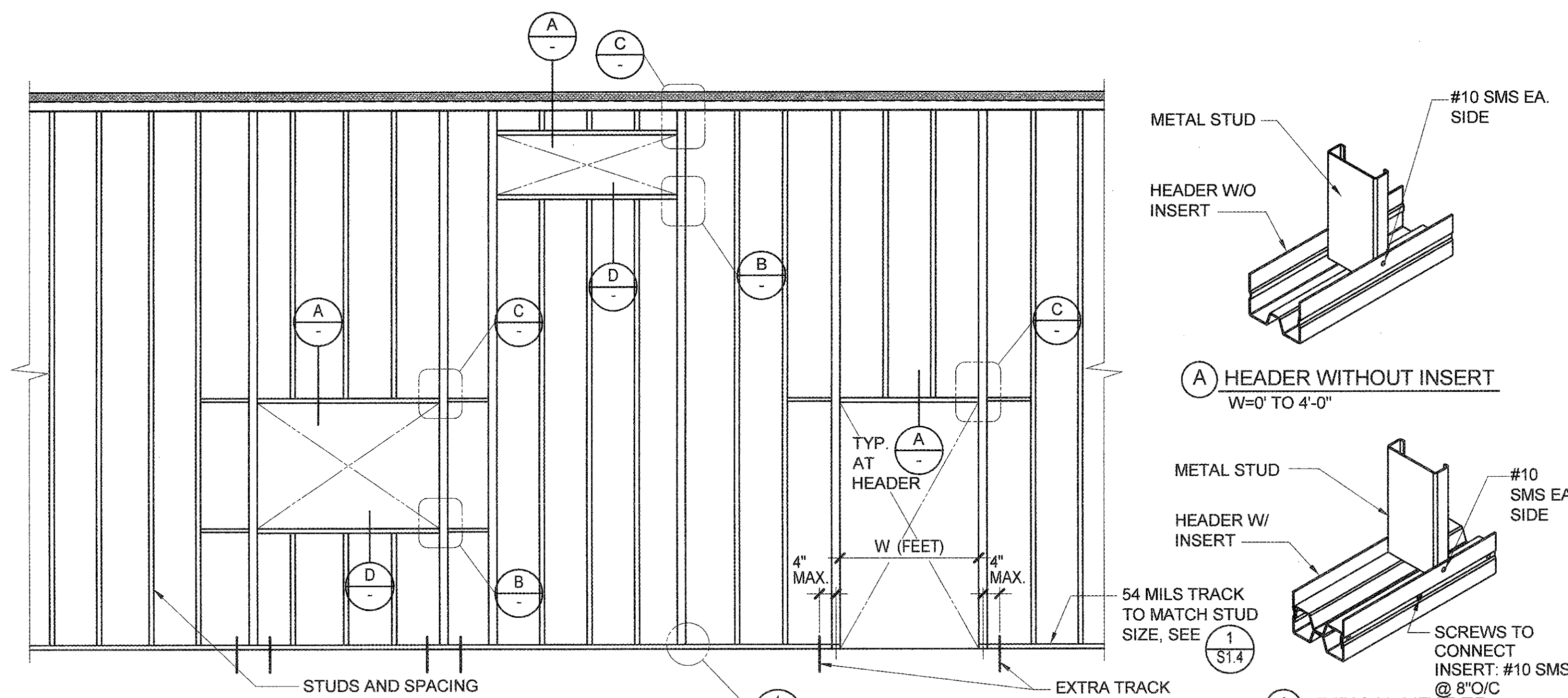

- METAL STUD:**
- ALL METAL STUDS SHALL BE SSMA METAL SYSTEM. TYP. @ 16" O.C. U.N.O. SEE (3) FOR INTERIOR METAL STUD SIZE AND PROPERTIES (S13)
 - HEADER SHALL BE PRO-X SYSTEM (UER 0286). SEE ARCH. DWG. FOR WALL THICKNESS & OPENING SIZE.

OPENING WIDTH (W)	HEADER SCHEDULE
4'-0" TO 6'-0"	HEADER: 400X425-43 OR 600X425-43
6'-1" TO 14'-0"	HEADER: 400XTC425-54 OR 600XTC425-54

3. IN LIEU OF BUILT-UP JAMB, SINGLE JAMB STUD MAY BE USED PER TABLE BELOW.

OPENING WIDTH (W)	JAMB
4'-0" TO 6'-0"	JAMB: 400HDS300-43 OR 600HDS300-43
6'-1" TO 14'-0"	JAMB: 400HDS300-54 OR 600HDS300-54

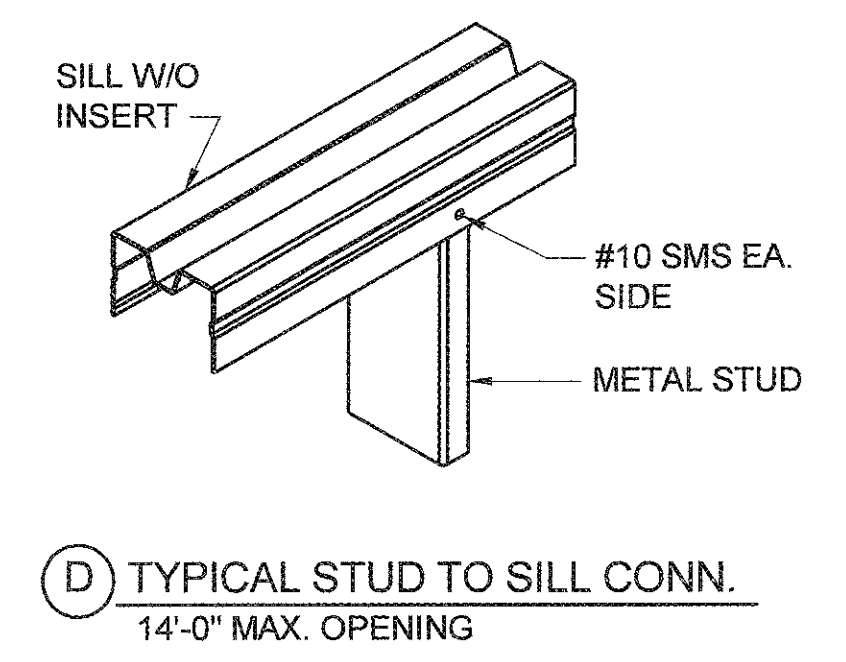
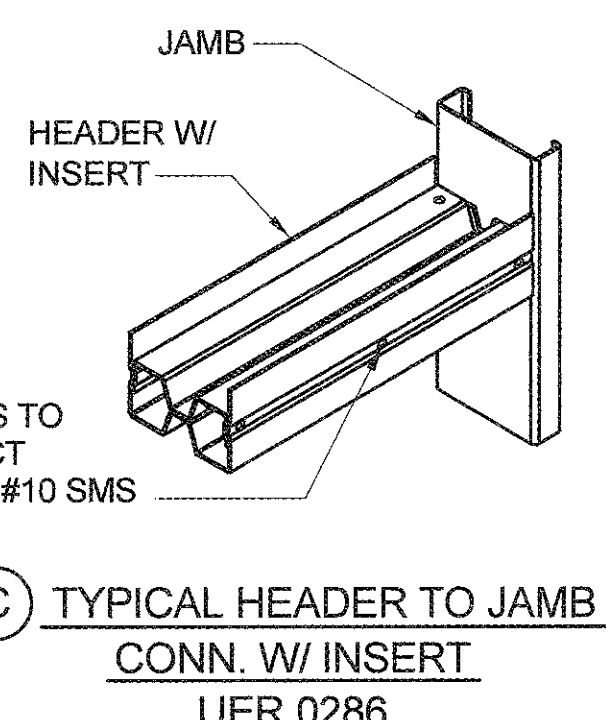
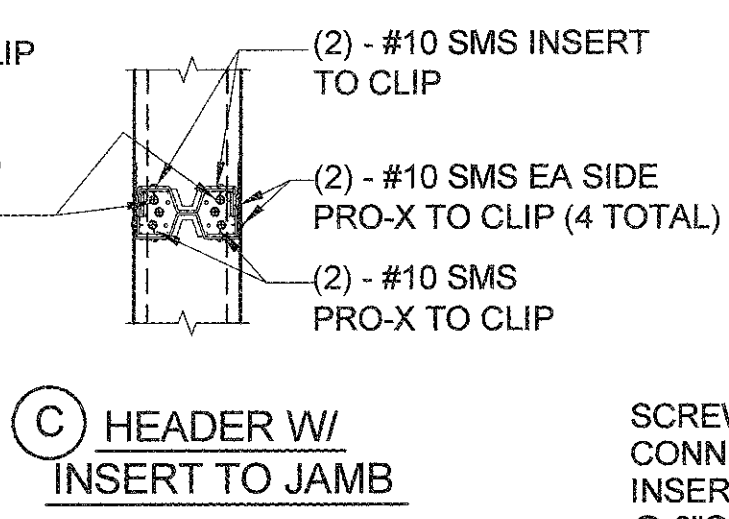
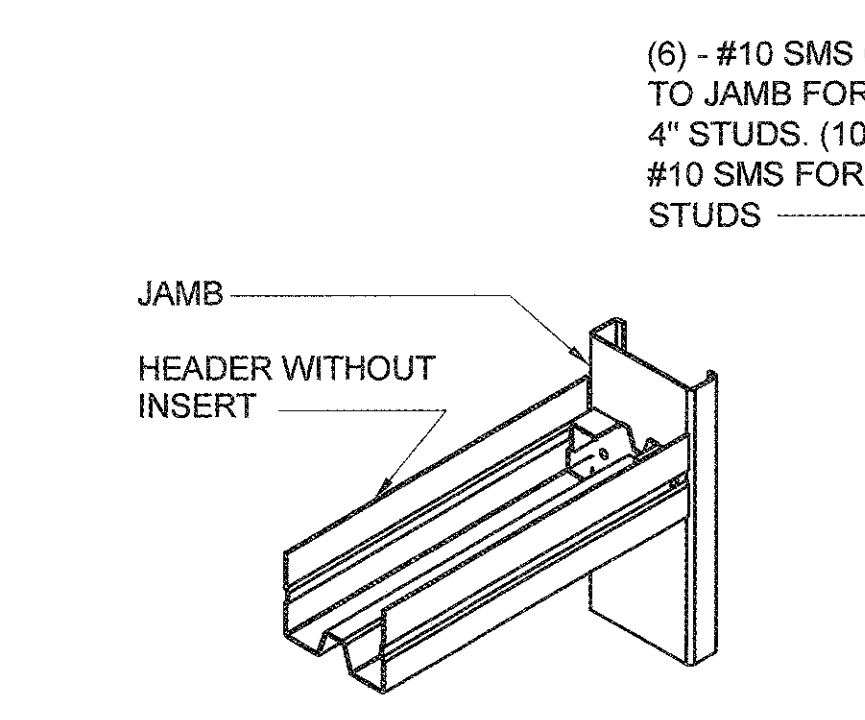
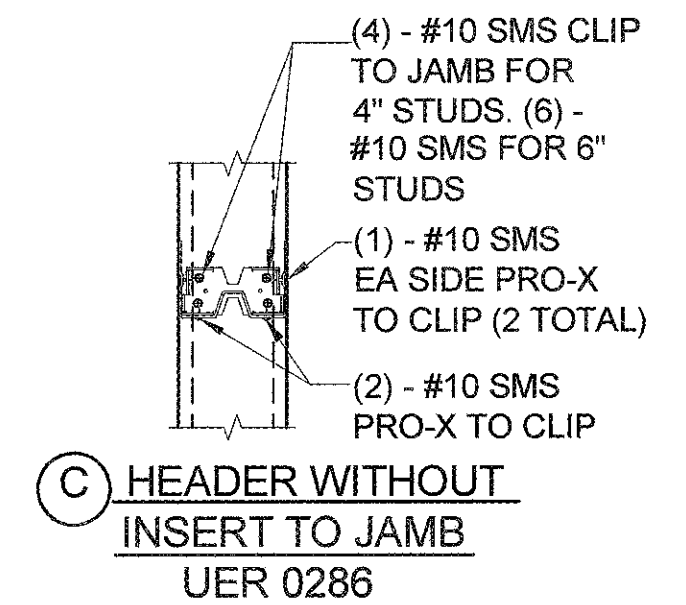
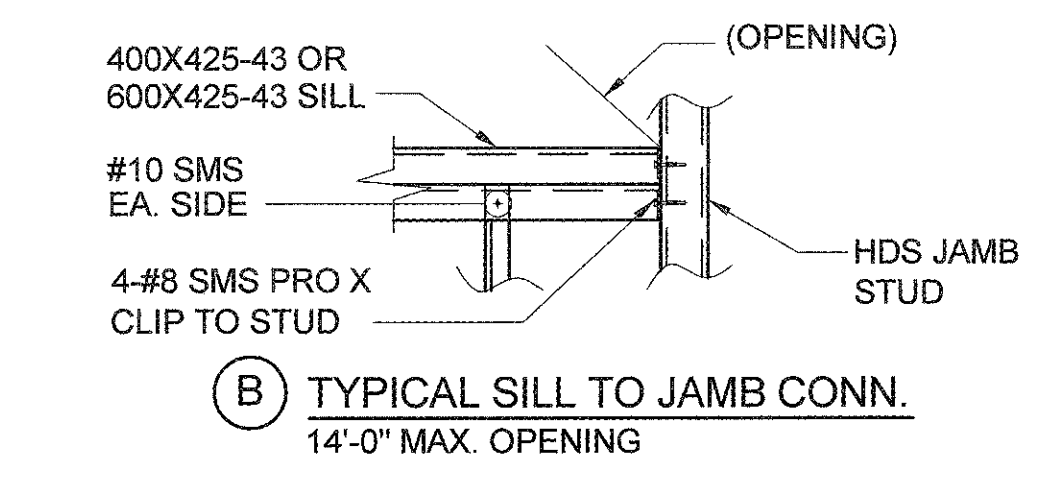

C TYPICAL HEADER TO JAMB CONN. WITHOUT INSERT

C TYPICAL HEADER W/ INSERT TO JAMB

C TYPICAL HEADER TO JAMB CONN. W/ INSERT UER 0286

D TYPICAL STUD TO SILL CONN. 14'-0" MAX. OPENING

TYP. INTERIOR NON-BEARING WALL FRAMING DETAIL (OPTIONAL) NONE 8

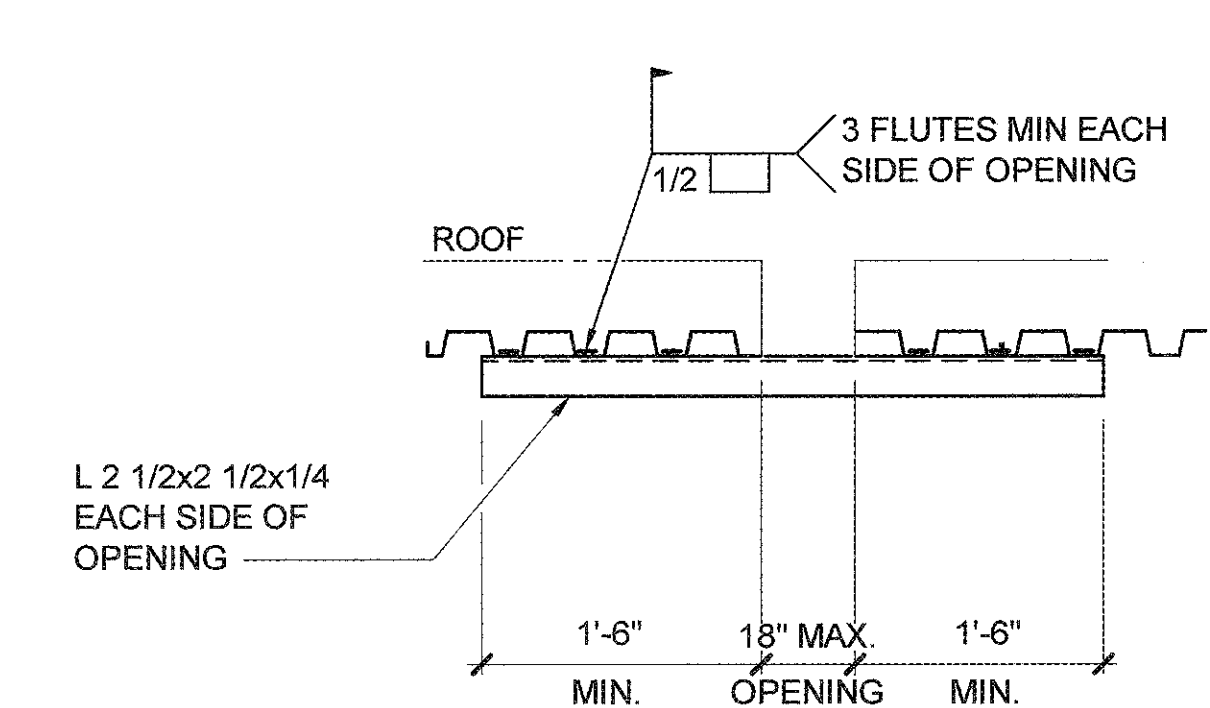
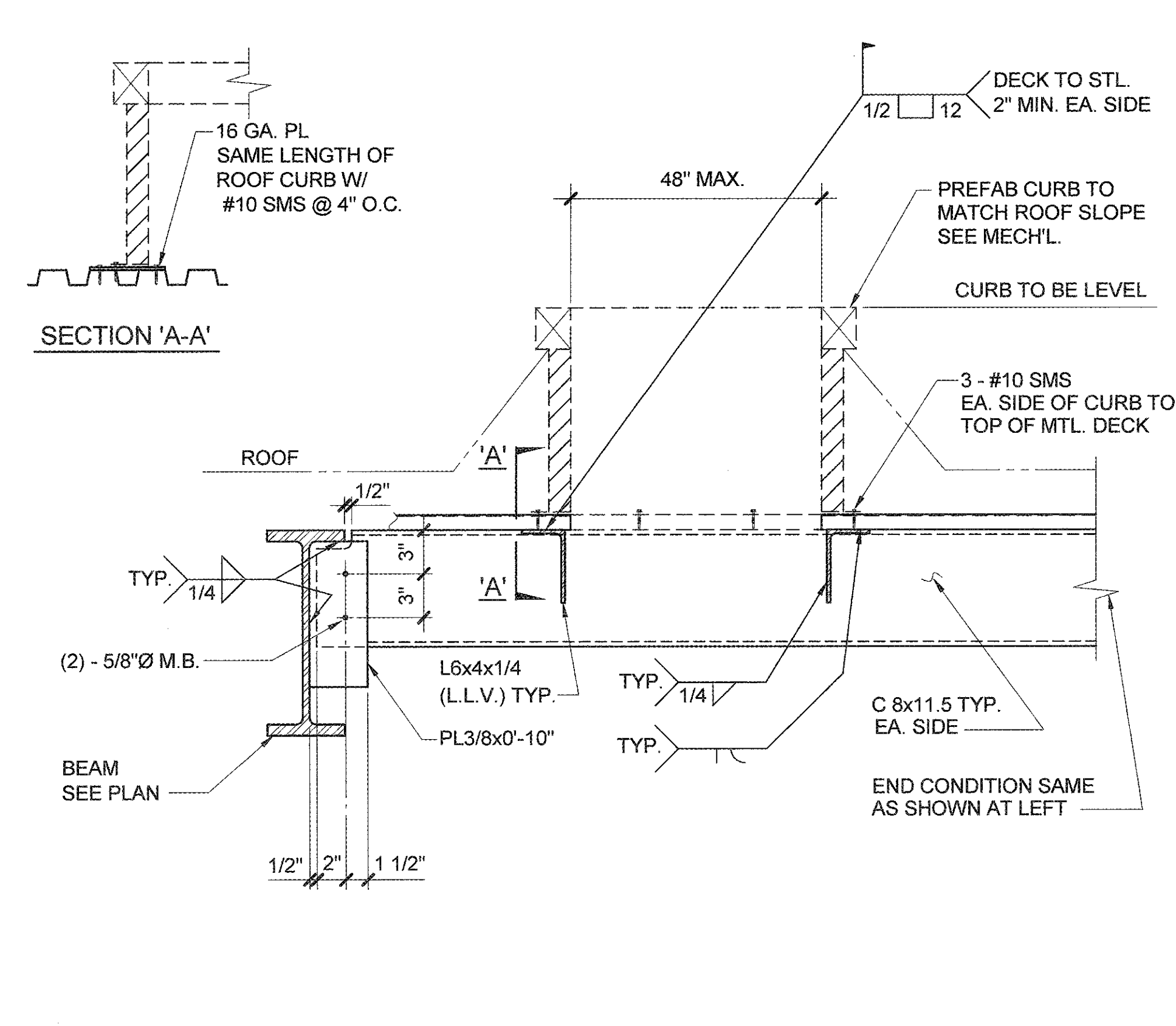

PROVIDE THIS DETAIL FOR OPENINGS 4" TO 18" MAX. DIMENSION WHERE NO CURB IS REQUIRED AND NO EQUIPMENT IS SUPPORTED. (U.N.O. ON PLANS)

- NOTES:**
- SEE ARCHITECTURAL, MECHANICAL, ELECTRICAL AND PLUMBING DRAWINGS FOR SIZE, LOCATION AND ANY ADDITIONAL REQUIREMENTS NOT NOTED ON THE STRUCTURAL DRAWINGS.
 - ALL OPENINGS SHALL BE AS SHOWN ON THE STRUCTURAL DRAWINGS, OR APPROVED BY THE STRUCTURAL ENGINEER.
 - MAXIMUM ANGLE SPAN = 6'-0"
 - FOR ROOF TOP EXHAUST FANS WITH MAX. OPERATING WT. OF 400 lbs. OR LESS, SEE MECH'L.
 - AROUND OPENING, WELD ROOF DECK TO CHANNEL AND ANGLE PER DETAIL (1)

TYPICAL ROOF OPENING DETAILS NONE 3

TYP. INTERIOR NON-BEARING WALL FRAMING DETAIL (OPTIONAL) NONE 8

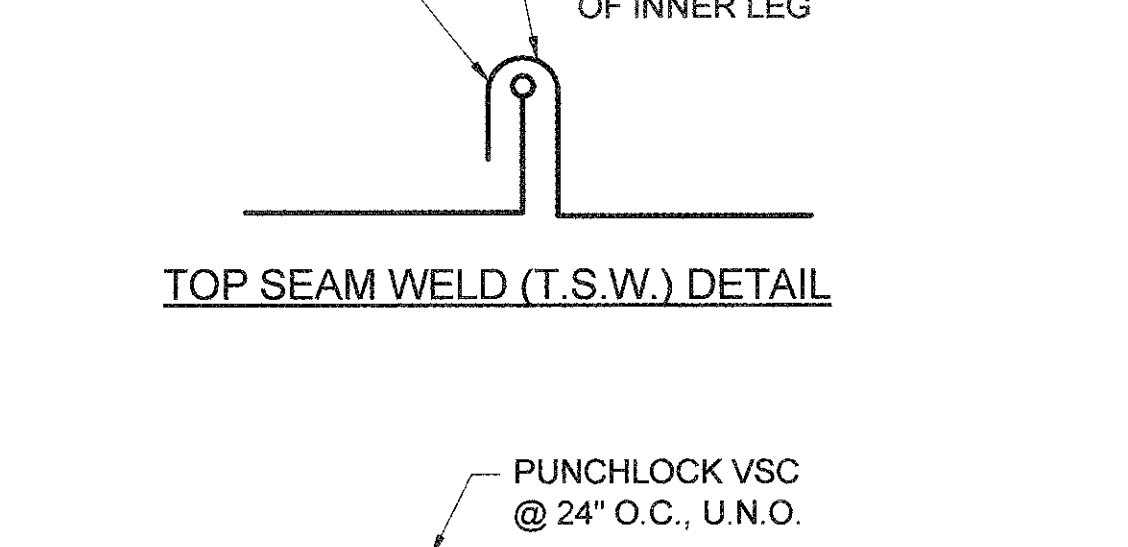
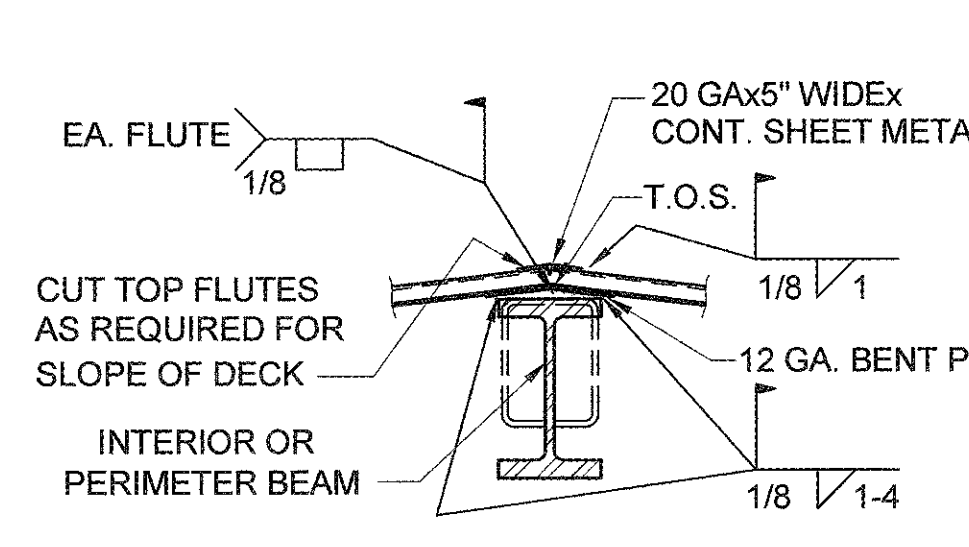
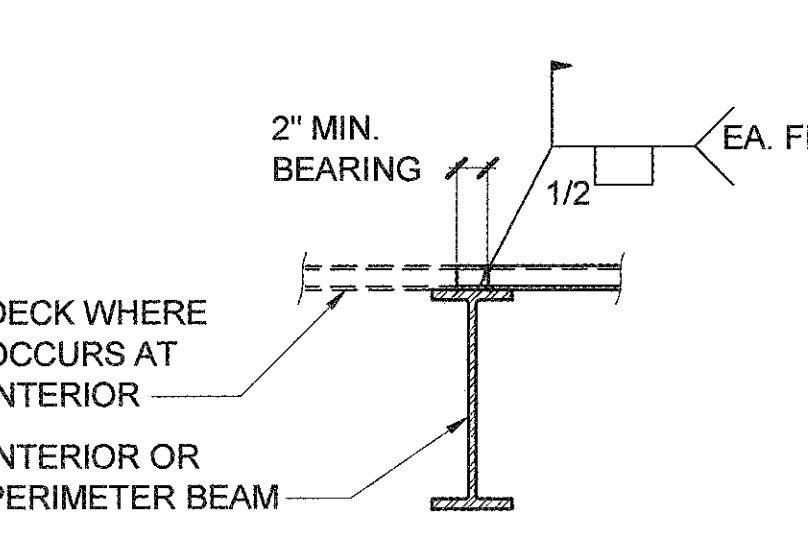
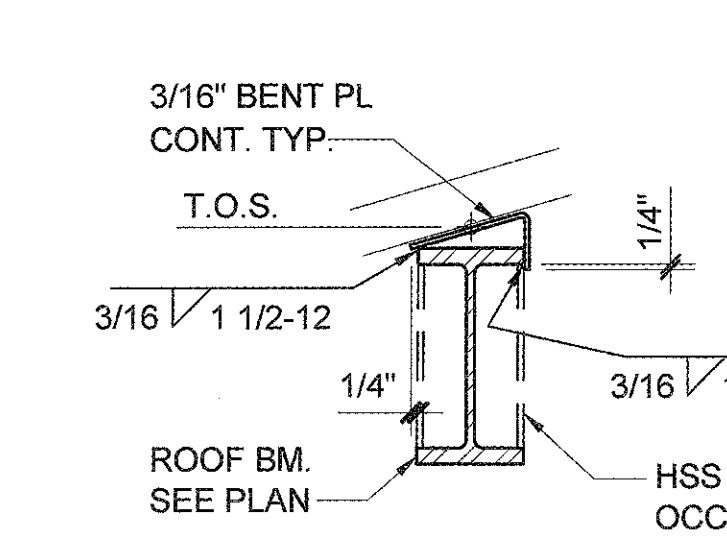
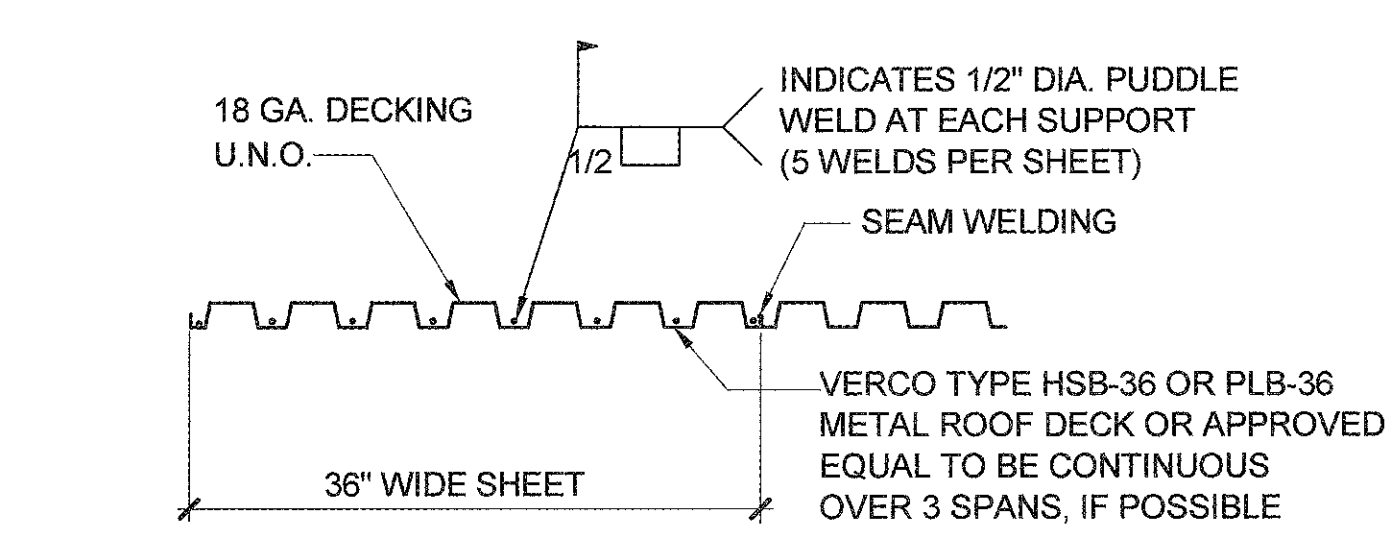
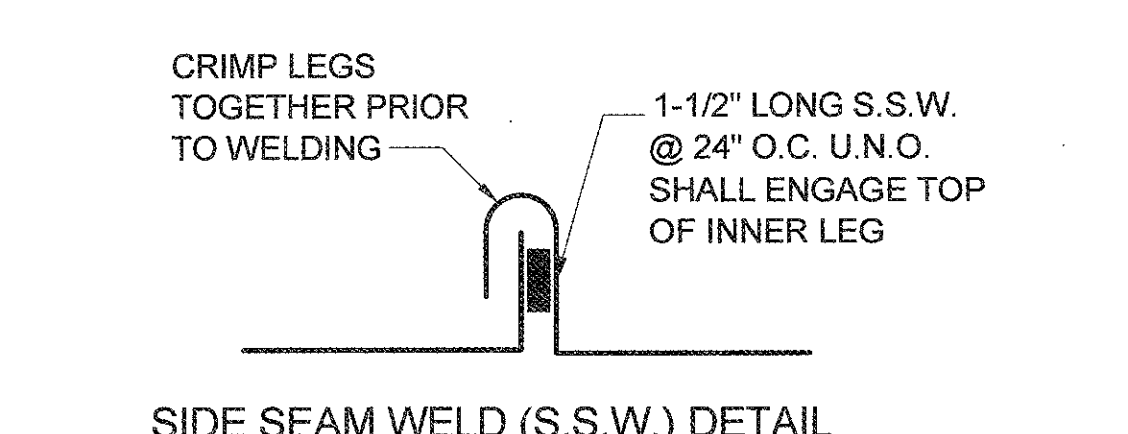
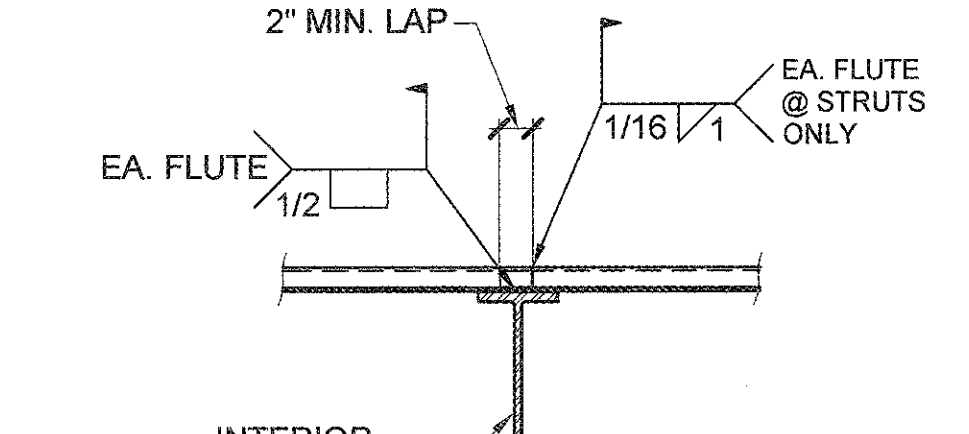
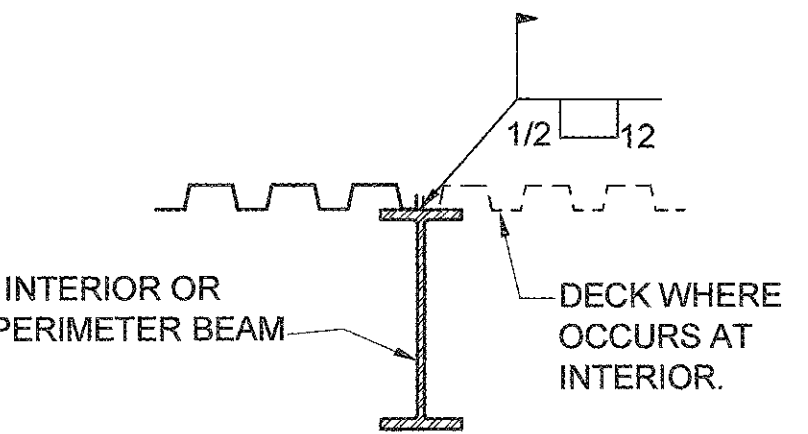
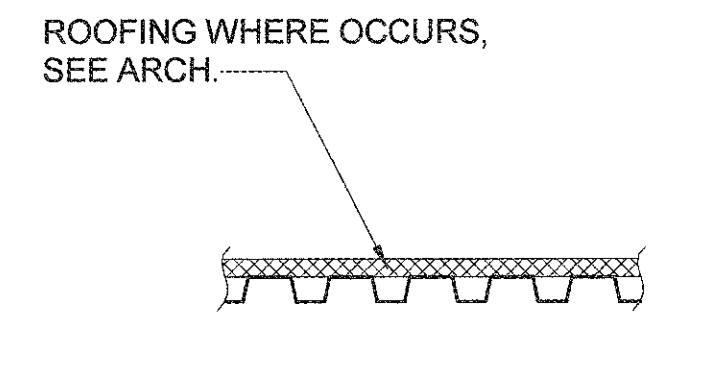
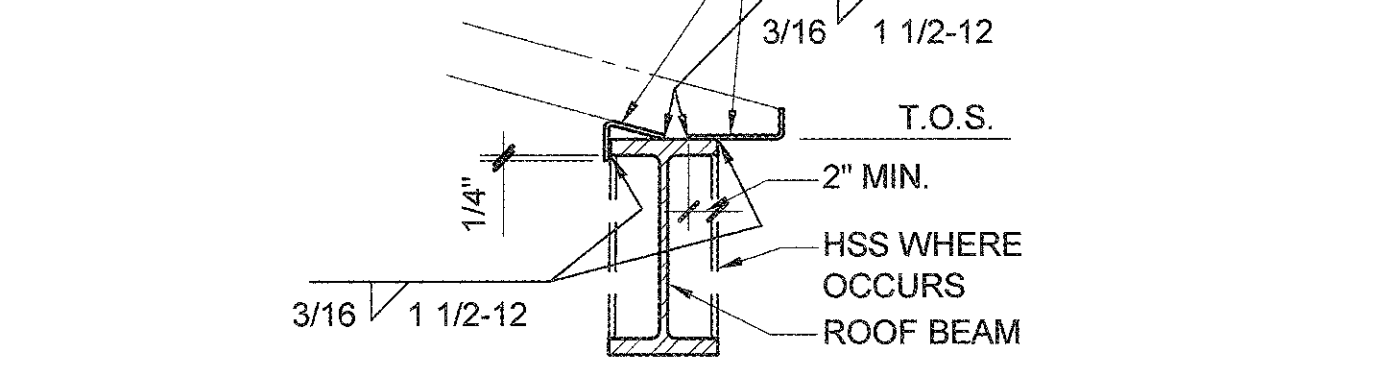

- NOTE:**
- SEE GENERAL NOTES FOR ADDITIONAL DECK INFORMATION.
 - () PROVIDE TWO ROWS OF WELDS @ 12" O.C. INDICATED ALONG INTERIOR STRUTS & ONE ROW OF WELD @ 12" O.C. AT EXTERIOR/PERIMETER OF BLDG.

TYPICAL ROOF DECK DETAILS NONE 1

NOT USED 5

NOT USED 2

NOT USED 2

NOT USED 2

NOT USED 2

NOT USED 2

NOT USED 2

NOT USED 2

NOT USED 2

NOT USED 2

NOT USED 2

NOT USED 2

NOT USED 2

NOT USED 2

LITTLE
DIVERSIFIED ARCHITECTURAL CONSULTING

1300 Dove Street, Suite 100
Newport Beach, CA 92660
T: 949.698.1400 F: 949.698.1433

www.littleonline.com

This drawing and the design shown are the property of Little Diversified Architectural Consulting. The reproduction, copying or other use of this drawing without their written consent is prohibited and any infringement will be subject to legal action.

© Little 2016

COMPTON CCD

CAMPUS PUBLIC SAFETY BUILDING

1111 EAST ARTESIA BOULEVARD,
COMPTON CALIFORNIA 90221

IDENTIFICATION STAMP
DIV. OF THE STATE ARCHITECT
OFFICE OF REGULATION SERVICES

FILE NO: 19-C1
AR: 03-117673

AC: [] RS: [] SS: []
DATE: DEC. 12 2017

TTG

STRUCTURAL
MECHANICAL
ELECTRICAL
CIVIL

901 Via Piemonte Suite 400
Ontario, California 91764
Phone: 909.477.8915 Fax: 909.477.8916
www.ttgroup.com Project No. 0216.4877.00

REGISTERED PROFESSIONAL ENGINEER
GERARDO CARRANZA
No. S2292
EX. 402228
STATE OF CALIFORNIA

PRINCIPAL IN CHARGE
RITA S. CARTER
PROJECT MANAGER

SHOJI TAKEISHIMA / DAVID PHAN
DRAWN BY

GERARDO CARRANZA
REVISIONS

NO	REASON	DATE

REVISIONS

REVISIONS

REVISIONS

REVISIONS

REVISIONS

REVISIONS

REVISIONS

REVISIONS

REVISIONS

REVISIONS

PROJECT NUMBER
913-4675-01

DATE
11/21/17

SCALE
S1.5

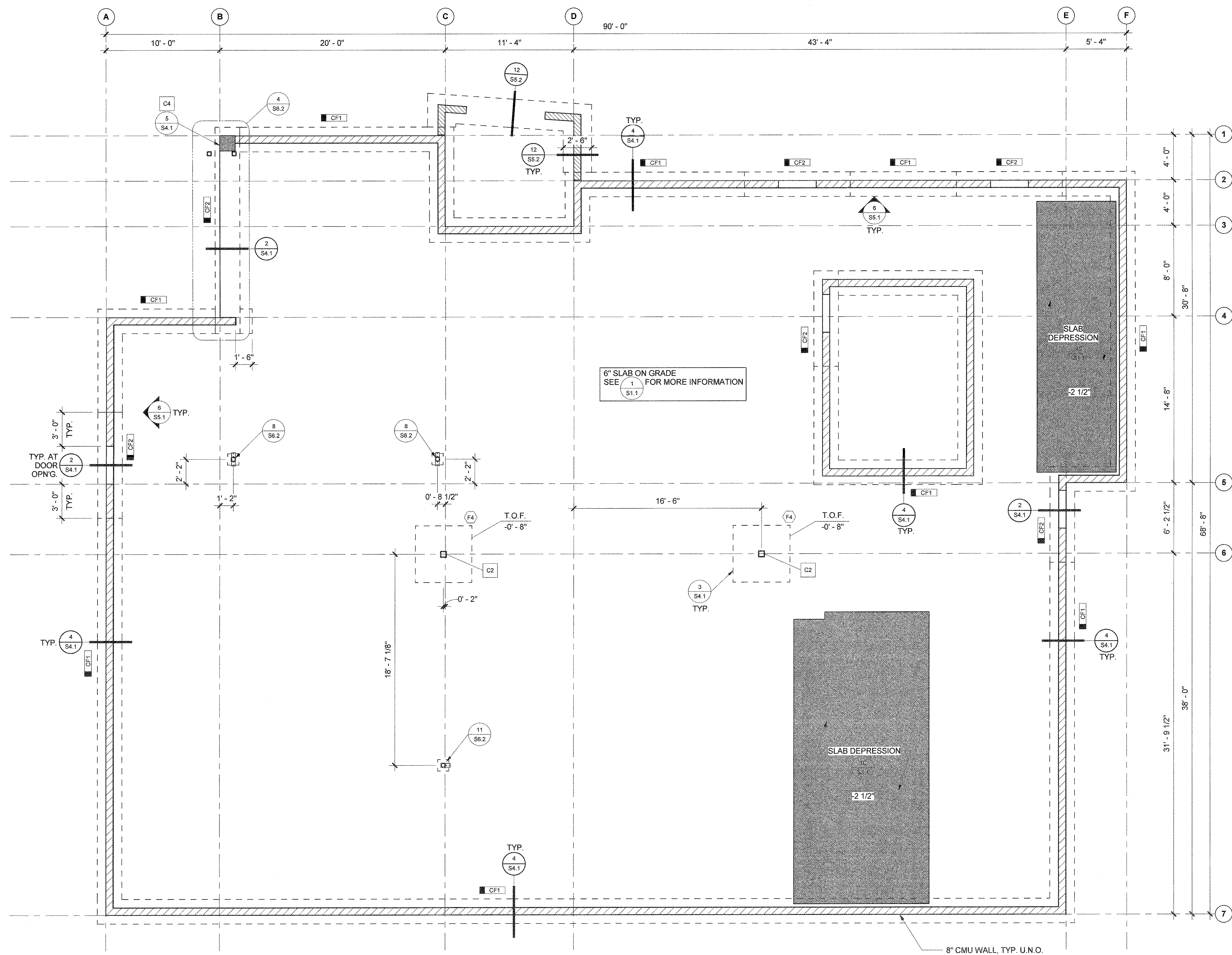

COLUMN SCHEDULE				
MARK	COLUMN SIZE	BASE PLT. THK.	WELD SIZE	SIZE AND NO. OF FDN. A.B. U.N.O.
C2	HSS6x6x1/4	5/8"	1/4"	(4) 3/4"Ø x 12" A.B.
C4	16"16" CMU PILASTER (W/ 3000PSI CONC.)	(8) #5	#4 TIES @ 8" O.C.	N/A

PAD FOOTING & CAISSON SCHEDULE		
MARK	SIZE	REINFORCEMENT
F4	5'-0"x5'-0"x1'-9"	5-#6 EA. WAY

CONTINUOUS FOOTING SCHEDULE			
MARK	WIDTH	DEPTH	REINFORCEMENT
CF1	2'-2"	18"	2-#5 TOP AND 3-#5 BOTT. W/ #4 TIES @ 12" O.C.
CF2	2'-2"	3'-0"	3-#5 TOP AND 5-#5 BOTT. IN ADDITION TO CF1

- FOUNDATION NOTES:**
- REFER TO SHEETS S0.1 & S0.2 FOR GENERAL NOTES.
 - REFER TO SHEETS S1.1 THRU S1.5 FOR TYPICAL DETAILS.
 - ALL DIMENSIONAL INFORMATION SHOWN IS BASED ON THE ARCHITECTURAL DRAWINGS. FOR ANY DIMENSIONAL INFORMATION NOT SHOWN REFER TO THE ARCHITECTURAL DRAWINGS.
 - ALL SLAB OPENINGS, EDGES, PADS, CURBS, FLOOR SLOPES, DRAINS, TRENCHES, STEPS, EXTERIOR PAVING AND DEPRESSIONS SHALL BE LOCATED AND COORDINATED PER THE ARCHITECTURAL AND CIVIL DRAWINGS.
 - EQUIPMENT NOT SHOWN ENTIRELY FOR CLARITY, COORD. WITH ARCH'L. & MEP, DWG.
 - PROVIDE CORNER BARS AT ALL FOOTING OR GRADE BEAM INTERSECTIONS FOR ALL PERPENDICULARS LONGITUDINAL FOOTING REINFORCING.
 - CONTINUOUS FOOTING OR GRADE BEAM REINFORCING TO BE CONTINUED THROUGH ISOLATED PAD FTGS.

- FOR TYPICAL FOOTING FORMING DETAIL, SEE 3/S1.1
- FOR TYPICAL PIPE TRENCH DETAIL, SEE 10/S1.1
- FOR TYPICAL STRUCTURAL SLAB AND GRADE BEAM CONSTRUCTION JOINT DETAILS, SEE 1/S1.1 & 2/S1.2
- FOR TYPICAL REINFORCING AT FOOTING INTERSECTION SEE DETAIL 1/S1.2
- SITE PREPARATION FOR FOOTING AND SLAB ON GRADE SEE 9/S4.1
- EXTEND 3'-0" BEYOND EDGE OF OPENING BOTH SIDES, TYP. SEE 10/S1.2 FOR MORE INFO.
- NON-BEARING WALL FOOTING SEE 5A/S1.1

- LEGEND:**
- C1 - INDICATES COLUMN SIZE, SEE SCHEDULE
 - F1 - INDICATES PAD FOOTING SIZE, SEE SCHEDULE
 - CF1 - INDICATES CONTINUOUS FOOTING SIZE, SEE SCHEDULE
 - T.O.F. - INDICATES TOP OF FOOTING ELEVATION
 - INDICATES 8" CMU WALL PER PLAN W/ #5 VERT. @ 16" O.C. AND #5 HORIZ. @ 16" O.C. (ONE LAYER)
 - 2 1/2' - INDICATES DEPRESSION IN SLAB.

FOUNDATION PLAN

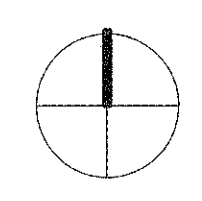

1/4" 1

LITTLE
DIVERSIFIED ARCHITECTURAL CONSULTING

1300 Dove Street, Suite 100
Newport Beach, CA 92660
T: 949.698.1400 F: 949.698.1433
www.littleonline.com

This drawing and the design shown are the property of Little Diversified Architectural Consulting. The reproduction, copying or other use of this drawing without their written consent is prohibited and any infringement will be subject to legal action.

© Little 2016

CLIENT NAME
**COMPTON
CCD**

PROJECT NAME
CAMPUS PUBLIC SAFETY BUILDING

1111 EAST ARTESIA BOULEVARD,
COMPTON CALIFORNIA 90221

IDENTIFICATION STAMP
DIV. OF THE STATE ARCHITECT
OFFICE OF REGULATION SERVICES

FILE NO: 19-C1
AR: 03-117873

AC: _____ FL: _____ SS: **#2**
DATE: DEC. 12, 2017

REGISTERED PROFESSIONAL ENGINEER
TTG
TERRY C. TSAI, P.E.
No. S2292
Exp. 03/30/23

901 Via Piemonte Suite 400
Ontario, California 91764
Phone: 909.477.6815 Fax: 909.477.6816
Project No. 0216.4877.00
www.ttgcorp.com

REGISTERED PROFESSIONAL ENGINEER
STRUCTURAL
TERRY C. TSAI, P.E.
No. S2292
Exp. 03/30/23

PRINCIPAL IN CHARGE
RITA S. CARTER
PROJECT MANAGER

SHOJI TAKESHIMA / DAVID PHAN
DRAWN BY

GERARDO CARRANZA
REVISIONS

NO.	REASON	DATE

PROJECT TITLE
FOUNDATION PLAN

PROJECT NUMBER
913-4675-01

DATE
11/21/17

SHEET NO.
S2.1

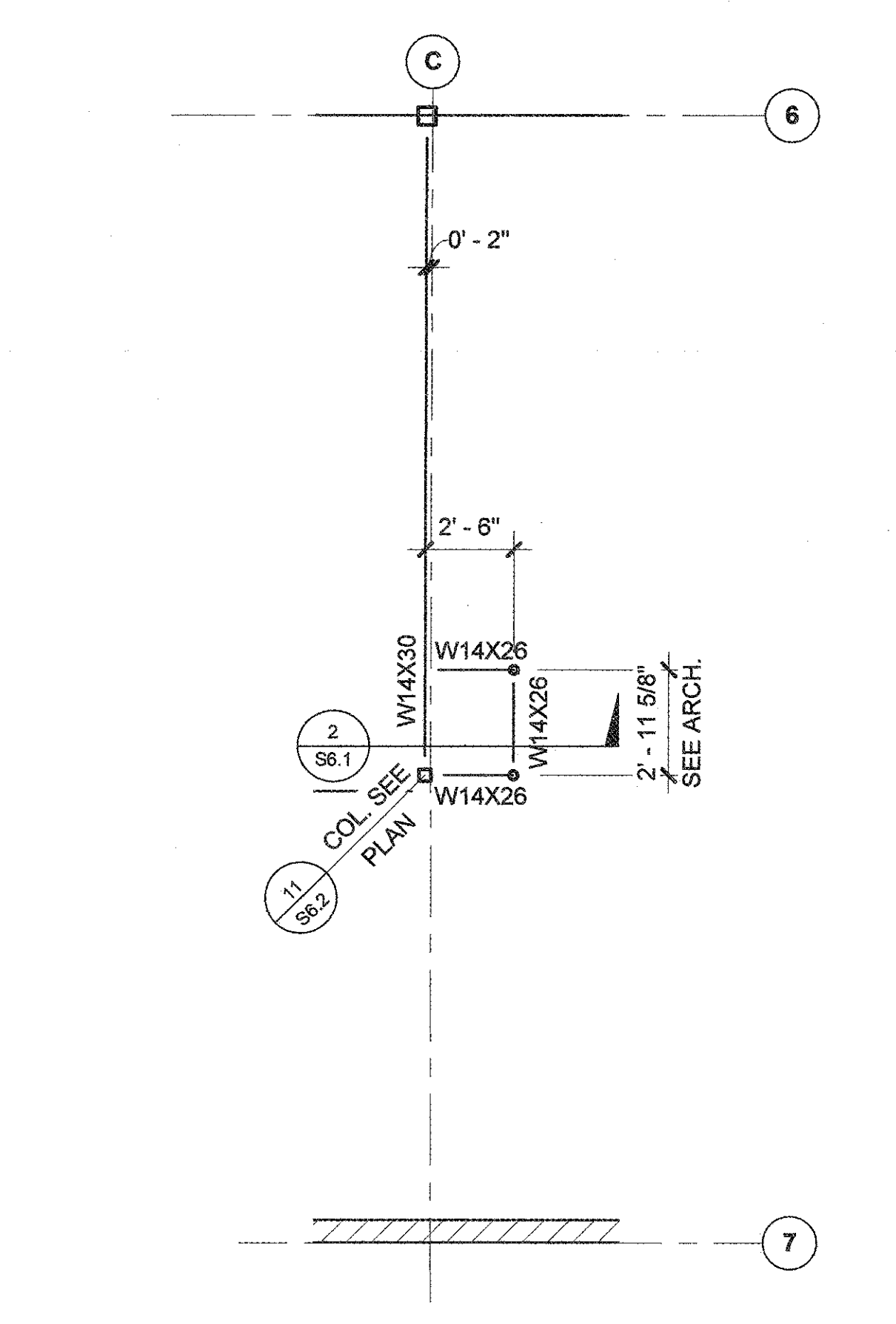
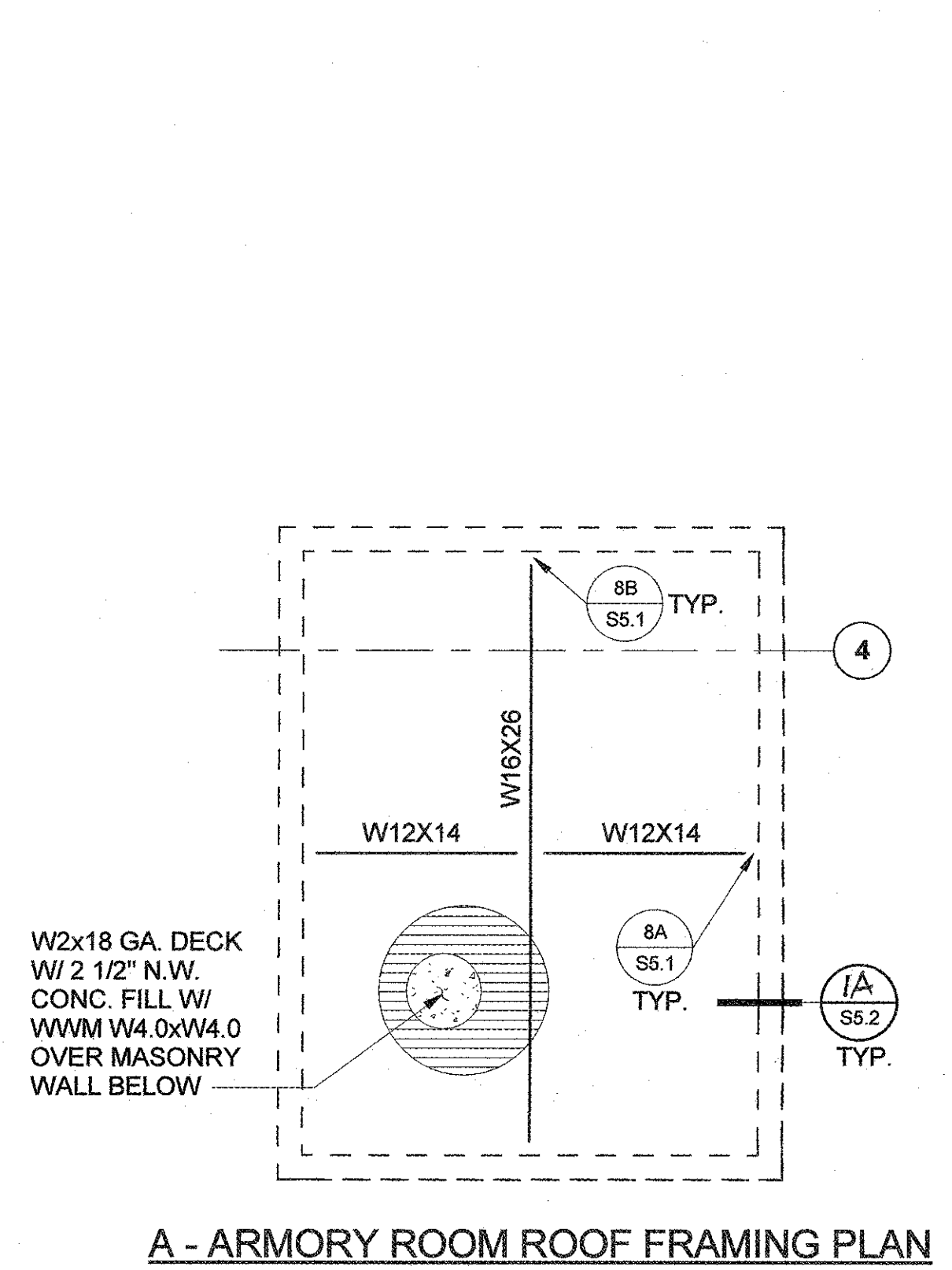
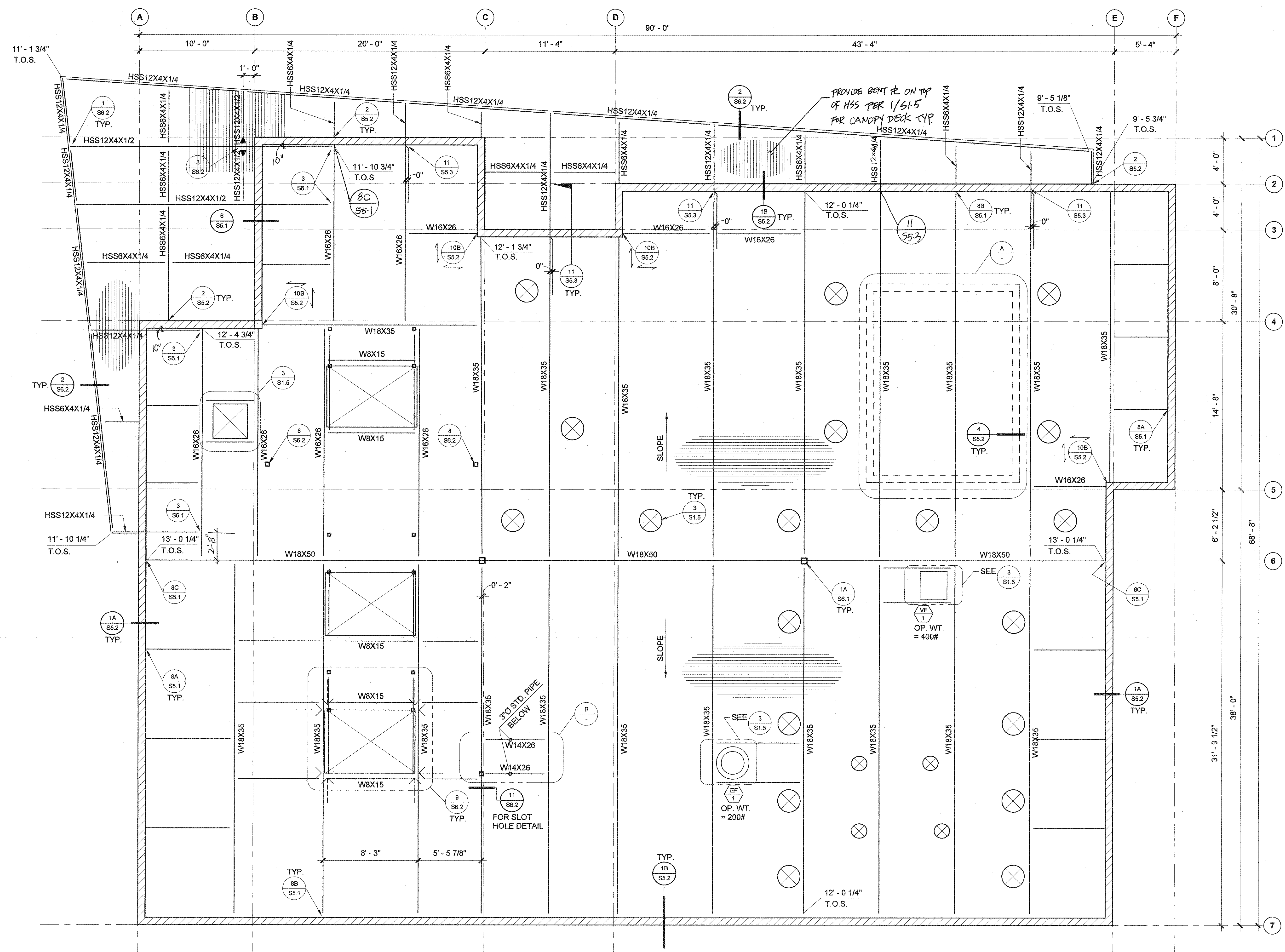

- REFERENCE NOTES:**
- REFER TO SHEETS S0.1 & S0.2 FOR GENERAL NOTES.
 - REFER TO SHEETS S1.1 THRU S1.5 FOR TYPICAL DETAILS.
 - ALL DIMENSIONAL INFORMATION SHOWN IS BASED ON THE ARCHITECTURAL DRAWINGS. FOR ANY DIMENSIONAL INFORMATION NOT SHOWN REFER TO THE ARCHITECTURAL DRAWINGS.
 - ALL SLAB OPENINGS, EDGES, PADS, CURBS, FLOOR SLOPES, DRAINS, TRENCHES, TEPS, EXTERIOR PAVING AND DEPRESSIONS SHALL BE LOCATED AND COORDINATED PER THE ARCHITECTURAL AND CIVIL DRAWINGS.
 - BEAM TO BE EQUALLY SPACED BETWEEN SUPPORTS U.N.O.
 - BEAMS SHOWN BUT NOT CALLED OUT SHALL BE W12x14.
 - TOP OF STEEL IS REFERENCE FROM FLOOR ELEVATION U.N.O.
 - WHEN PLACING CONCRETE FILL IN DECK, TOP OF SLAB SHALL BE SHOT TO TRANSIT LEVEL.
 - FOR COLUMN SIZES SEE FOUNDATION PLAN.
 - SEE 3/S1.5 FOR OPENINGS. ALSO, COORDINATE WITH M.E.P. & ARCH.

- LEGEND:**
- INDICATES BRACE PER 5/S6.1
 - INDICATES 1 1/2"x18GA. VERCO-DECK SEE 1/S1.5
 - INDICATES CMU WALL BELOW SEE FOUNDATION PLAN FOR SIZE.
 - INDICATES CMU WALL SEE FOUNDATION PLAN FOR SIZE.
 - INDICATES DRAG DIRECTION, DECK WELD TO STL. BEAM PER DETAIL 1/S1.5, TYP.
 - TOP OF STEEL OF SLOPING BEAMS ARE INDICATED THUSLY: SEE PLAN (0'-0")
TOP OF STEEL INDICATED THUSLY SHALL BE FOR ALL BEAMS FRAMING INTO COLUMN
 - MATCH SLOPE BETWEEN ADJACENT GRID LINE

- (A) SOILS BELOW THE BUILDING PAD AREA SHOULD BE OVER EXCAVATED PER SOIL REPORT BELOW EXISTING GRADES OR 3'-0" BELOW THE BOTTOM OF DEEPEST FOOTING, WHICHEVER IS GREATER AND BACKFILLED WITH SATISFACTORY BACKFILL MATERIAL COMPACTED TO A MIN. 90% PER SOIL REPORT IN 8" LIFTS, PER ASTM D1557.
- (B) 10 MIL THICK VISQUEEN OVER PROPERTY COMPACTED SUBGRADE
- (C) SLAB ON GRADE.
- (D) DEPTH OF COMPACTED FILL FOR NON-BEARING AREA, 2'-0" MIN.
- (E) SCARIFY 8" MOISTURE CONDITIONED AND COMPACT IN ACCORDANCE WITH THE RECOMMENDATIONS OF THE GEOTECHNICAL REPORT.
- (F) ALL EXPOSED SUBGRADE SOIL SURFACES, INCLUDING OVER-EXCAVATION BOTTOMS, SHOULD BE OBSERVED BY A REPRESENTATIVE OF GEOTECH. ENGINEER PRIOR TO PLACEMENT OF FILL.

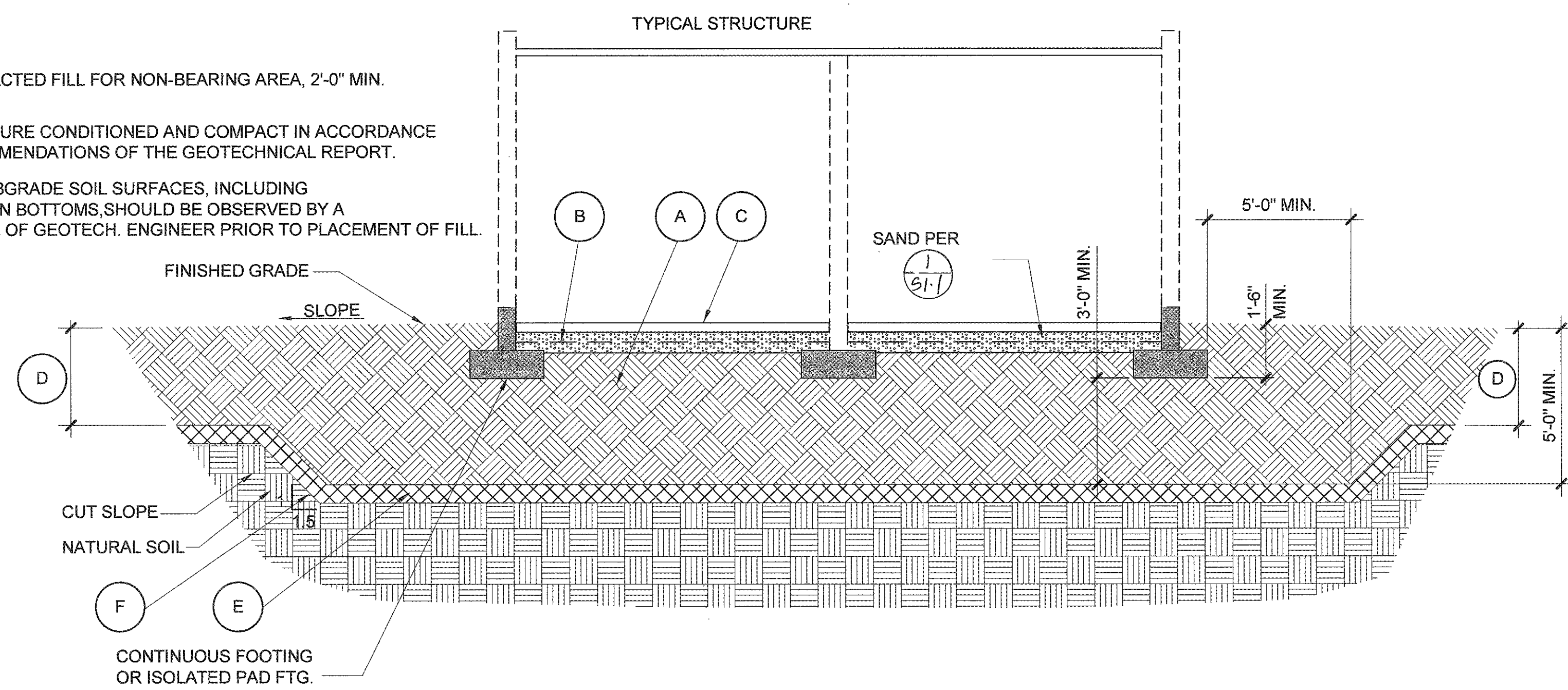

SITE PREPARATION FOR FOOTING AND SLAB ON GRADE

NONE 9

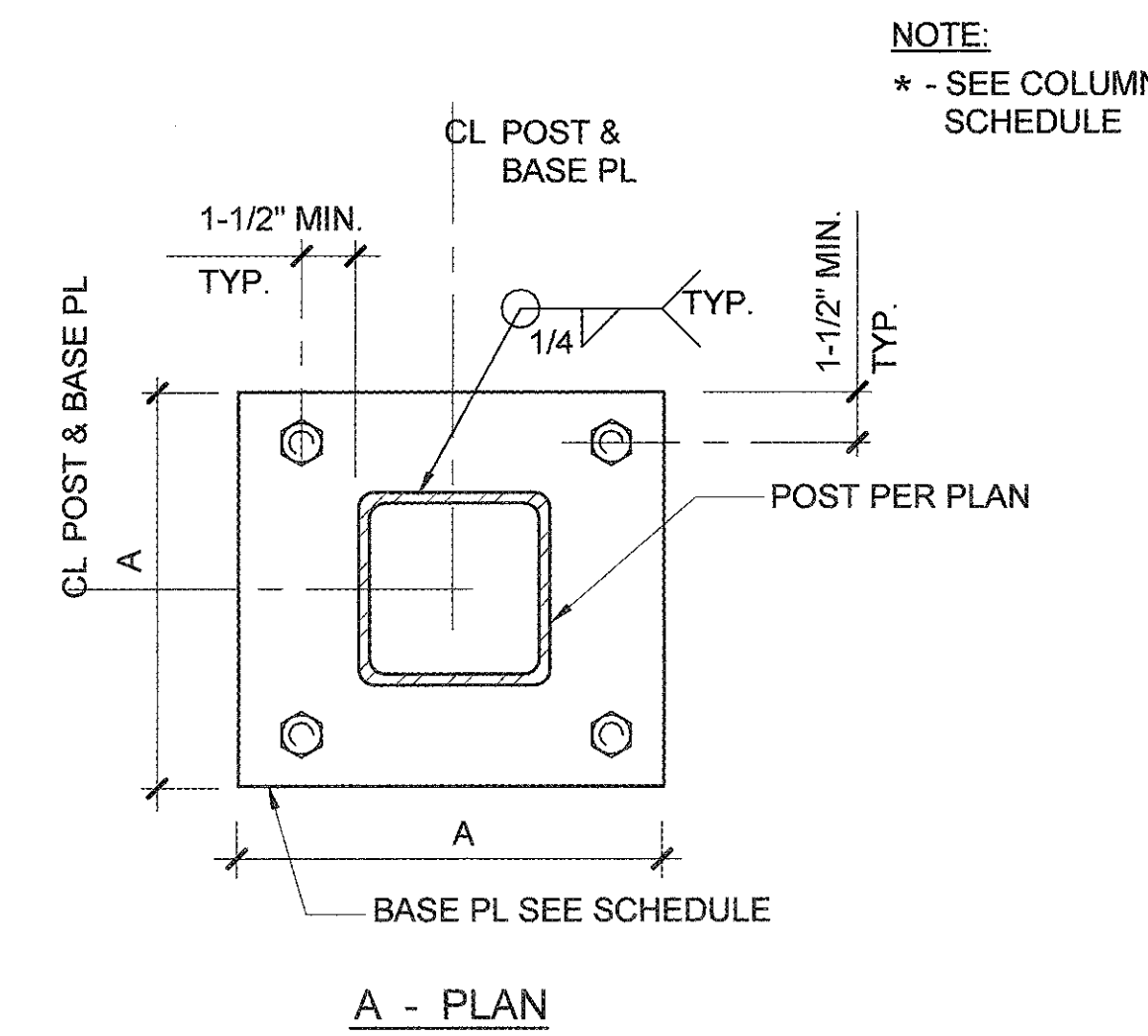

POST/BASE PLATE SCHEDULE			
COL. SIZE	"A" THICKNESS	ANCHORS	
HSS 6x6x1/4	12"	5/8"	(4)-3/4" DIA.

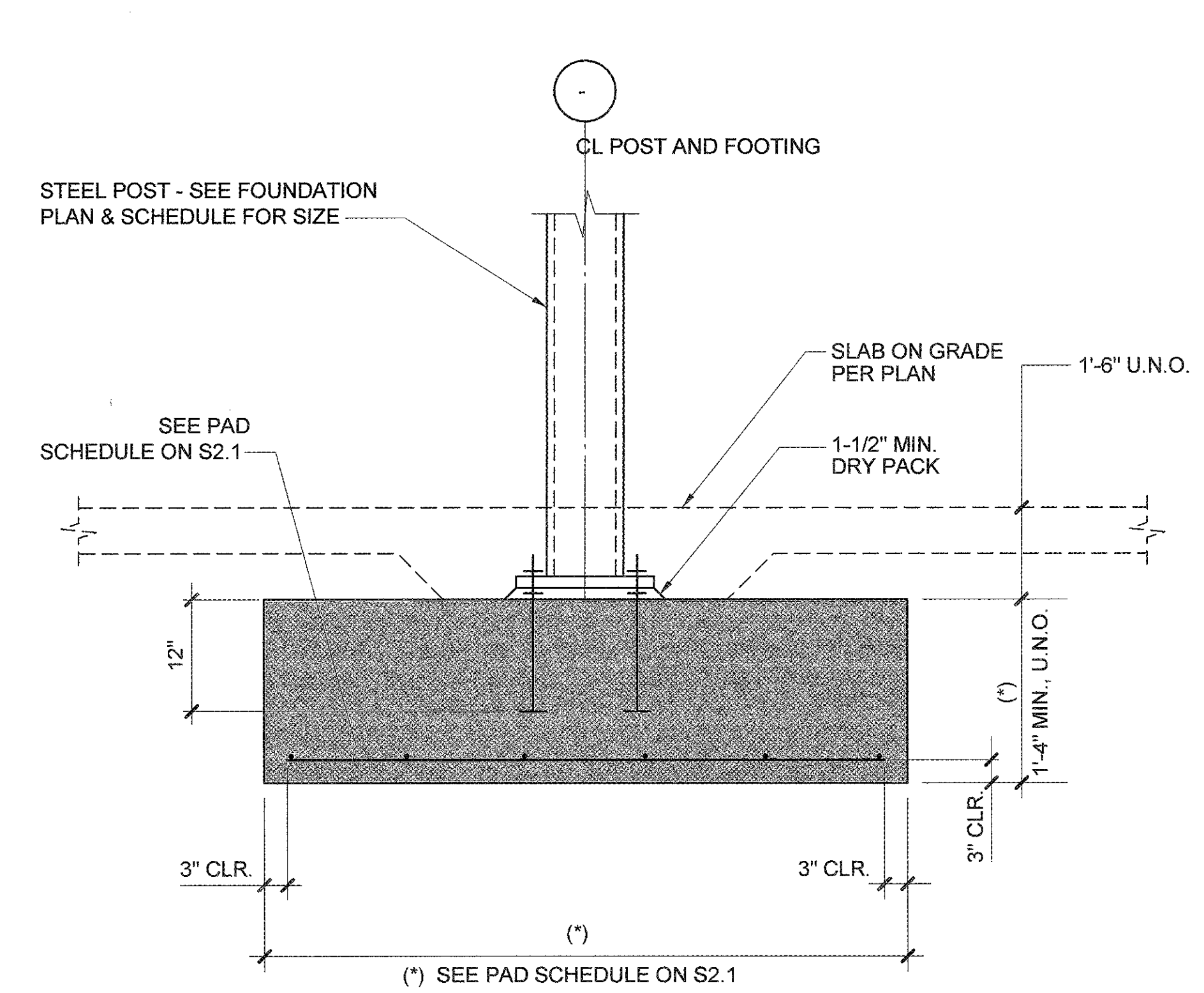

NOTE:
ADJUST REBAR LOCATION TO RECEIVE ANCHOR BOLT.

PAD FOOTING W/ HSS POST

NONE 3

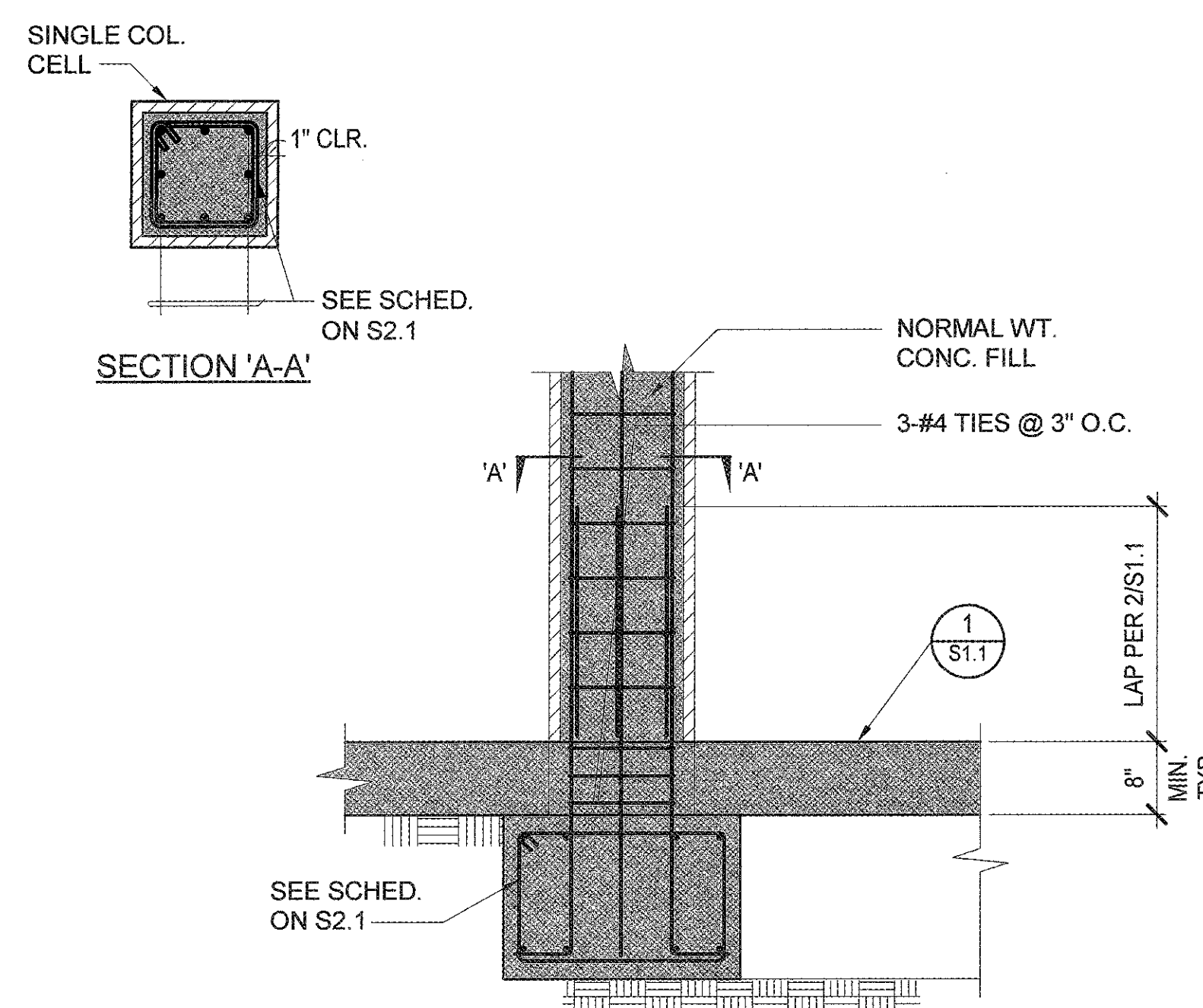

FOOTING DETAIL

NONE 5

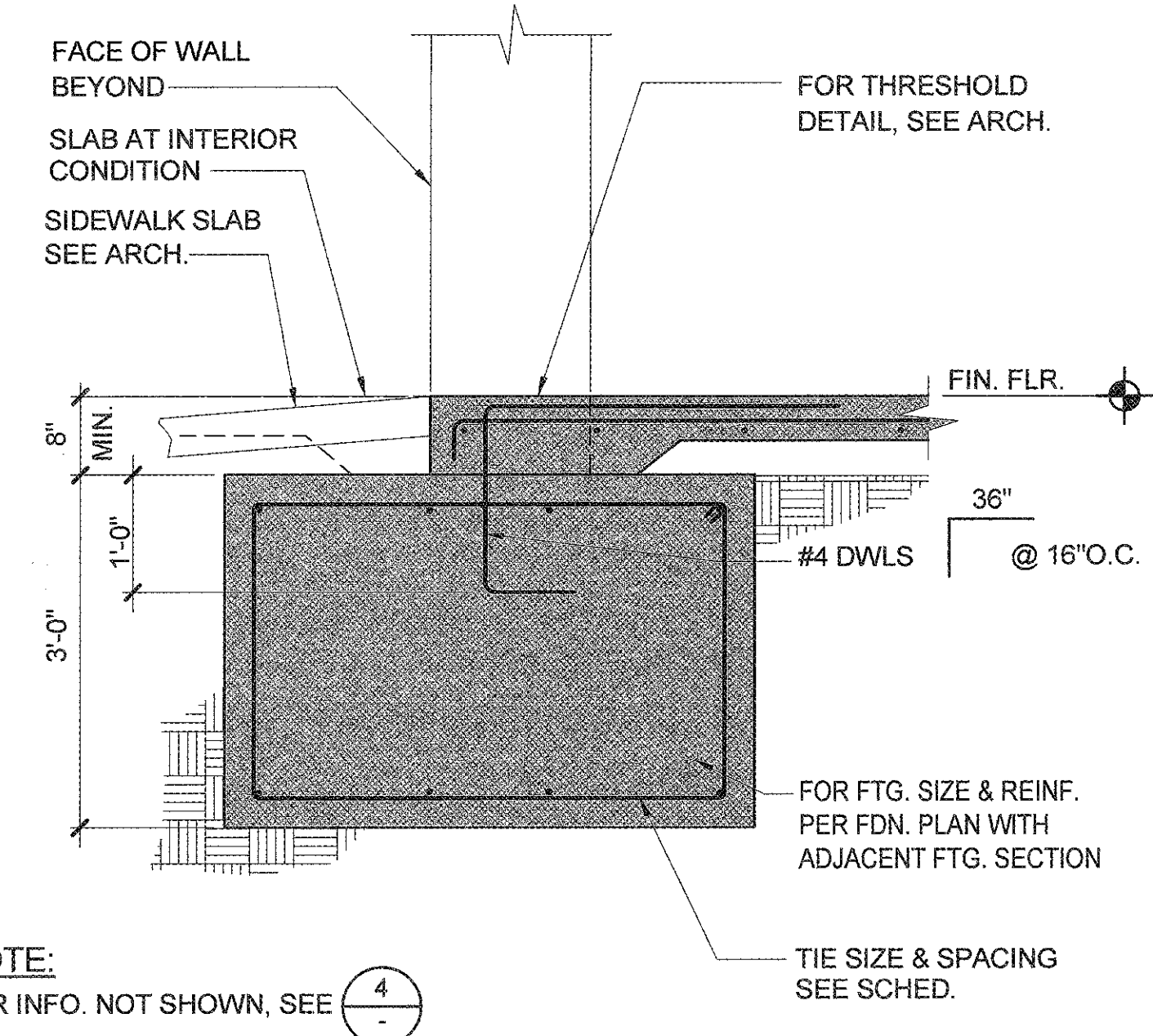

NOTE:
FOR INFO. NOT SHOWN, SEE (4)

FOOTING SECTION

NONE 2

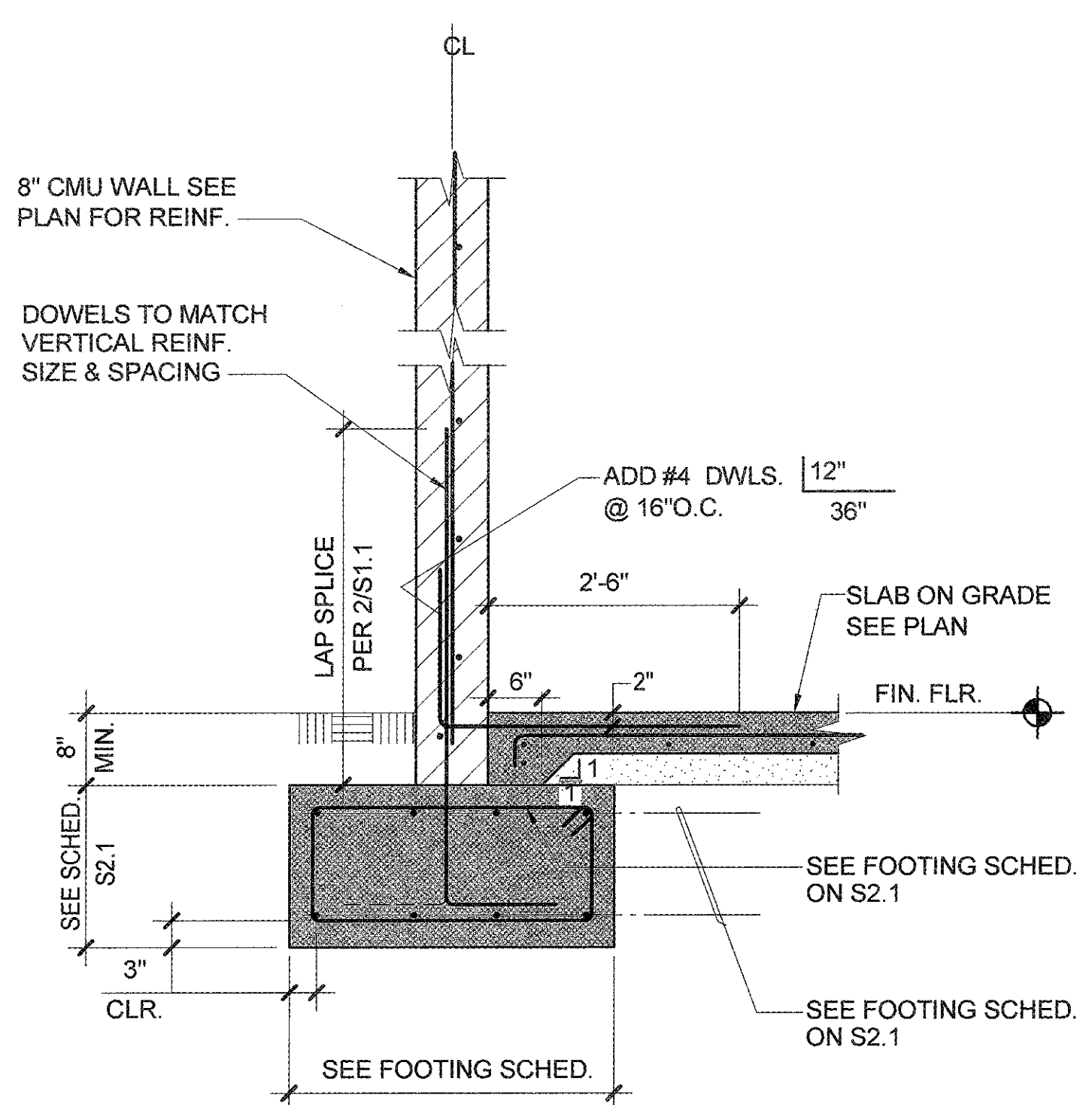

FOOTING SECTION

NONE 4

LITTLE
DIVERSIFIED ARCHITECTURAL CONSULTING

1300 Dove Street, Suite 100
Newport Beach, CA 92660
T: 949.698.1400 F: 949.698.1433
www.littleonline.com

This drawing and the design shown are the property of Little Diversified Architectural Consulting. The reproduction, copying or other use of this drawing without their written consent is prohibited and any infringement will be subject to legal action.

© Little 2016

COMPTON CCD

CAMPUS PUBLIC SAFETY BUILDING

1111 EAST ARTESIA BOULEVARD,
COMPTON CALIFORNIA 90221

IDENTIFICATION STAMP
DIV. OF THE STATE ARCHITECT
OFFICE OF REGULATION SERVICES

FILE NO: 19-C1
AR: 03-117673
AC: _____ FL: _____ SS: _____
DATE: 12/2/2017

TTG
• STRUCTURAL
• MECHANICAL
• ELECTRICAL
• CIVIL

901 Via Piemonte Suite 400
Ontario, California 91764
Phone: 909.477.8915 Fax: 909.477.8916
www.ttgcorp.com Project No. 0216.4877.00

REGISTERED PROFESSIONAL ENGINEER
TERRY C. TSHING
No. S2092
03/20/08
STRUCTURAL
STATE OF CALIFORNIA

PRINCIPAL IN CHARGE
RITA S. CARTER
PROJECT MANAGER

SHOJI TAKESHIMA / DAVID PHAN
DRAWN BY
GERARDO CARRANZA

NO	REASON	DATE

FOUNDATION DETAILS

913-4675-01

11/21/17 S4.1

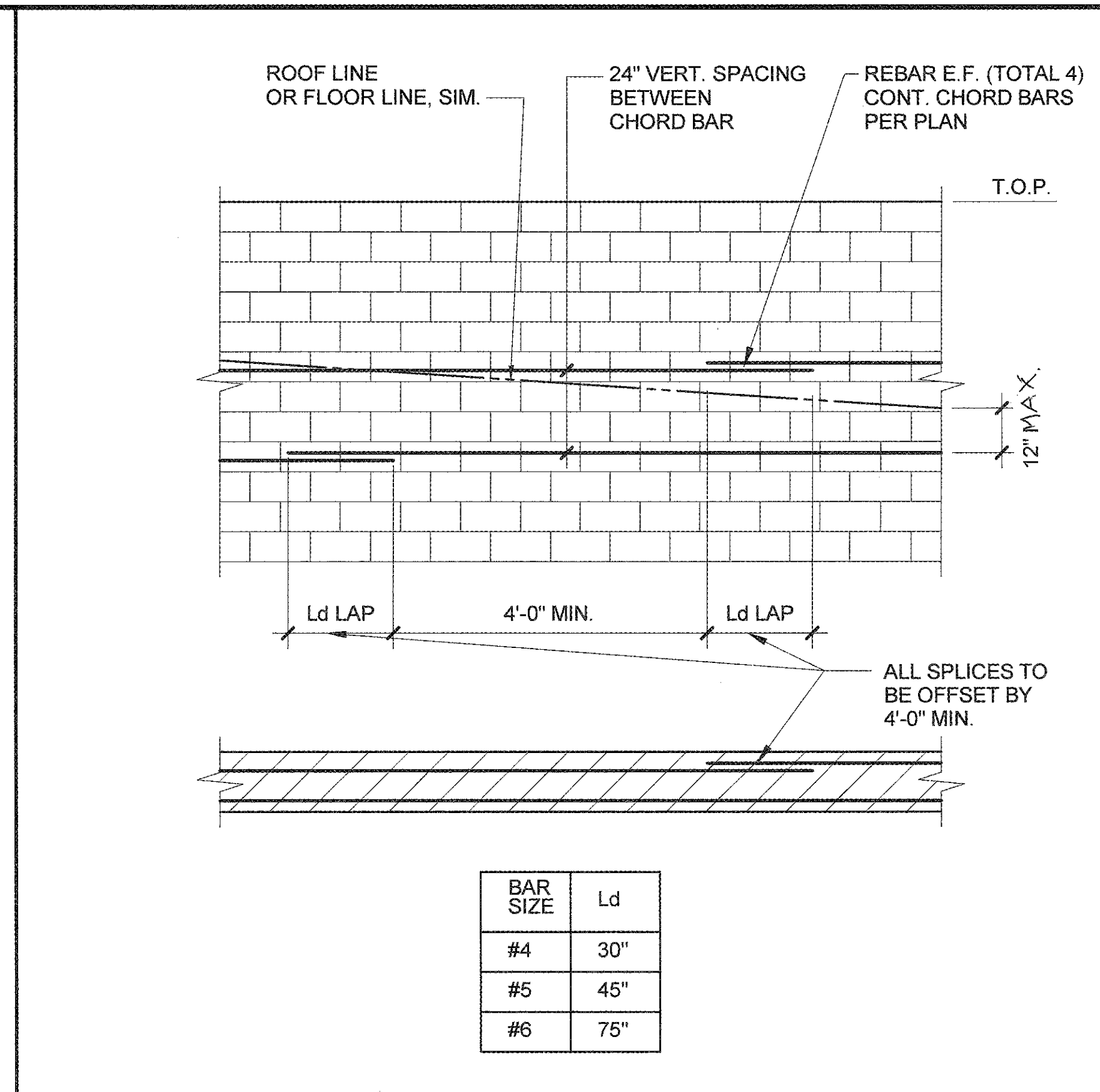
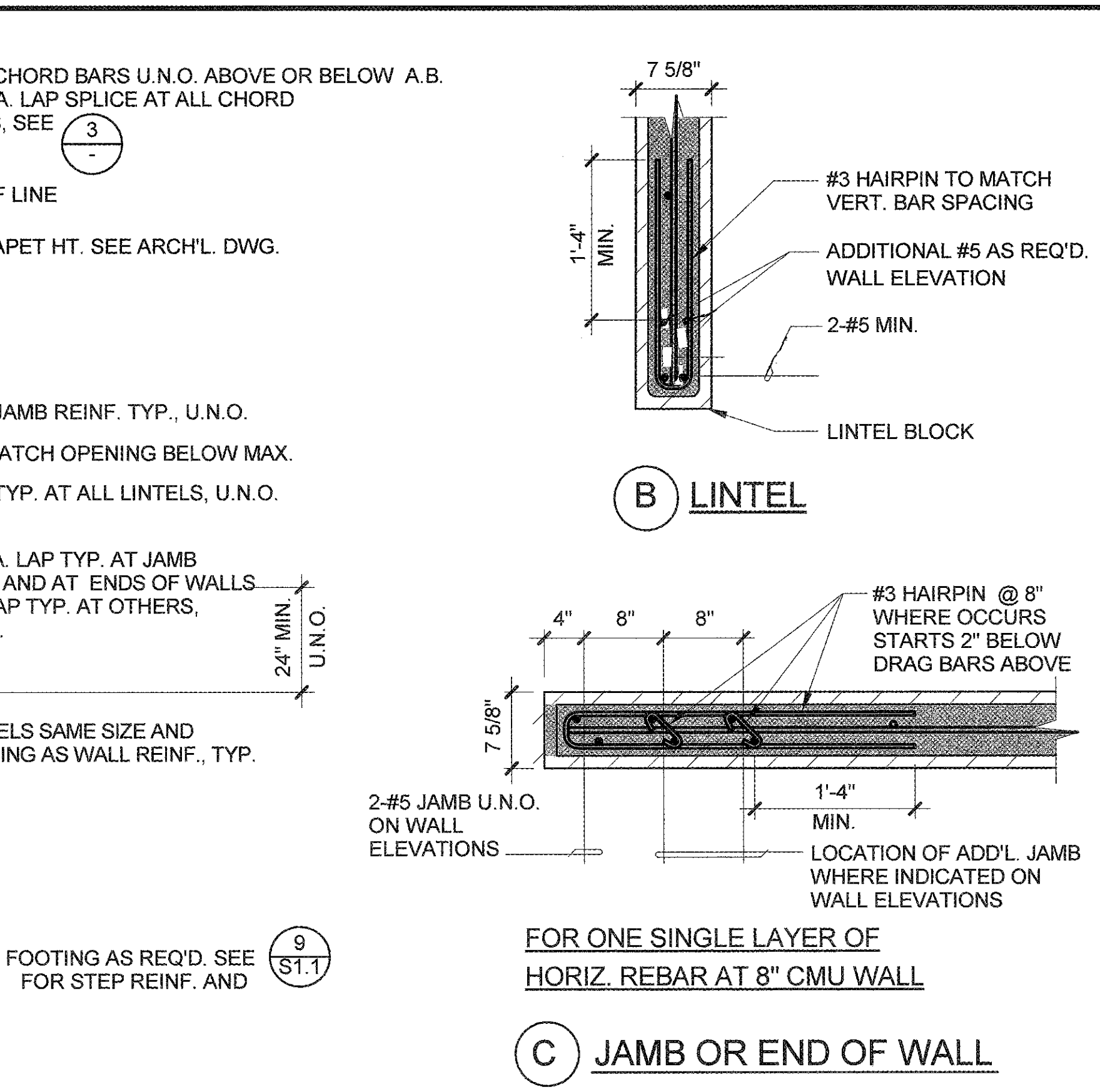
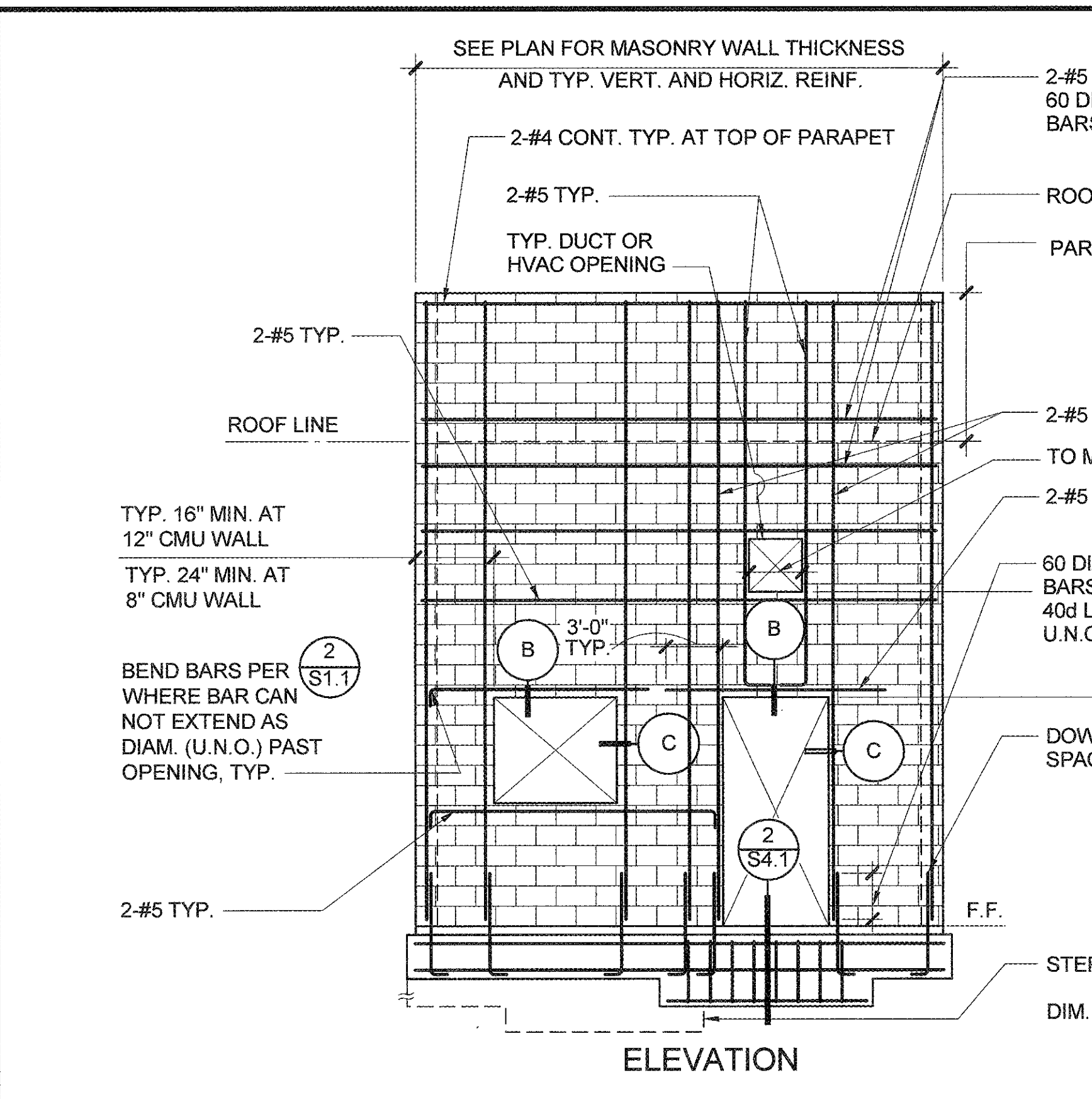
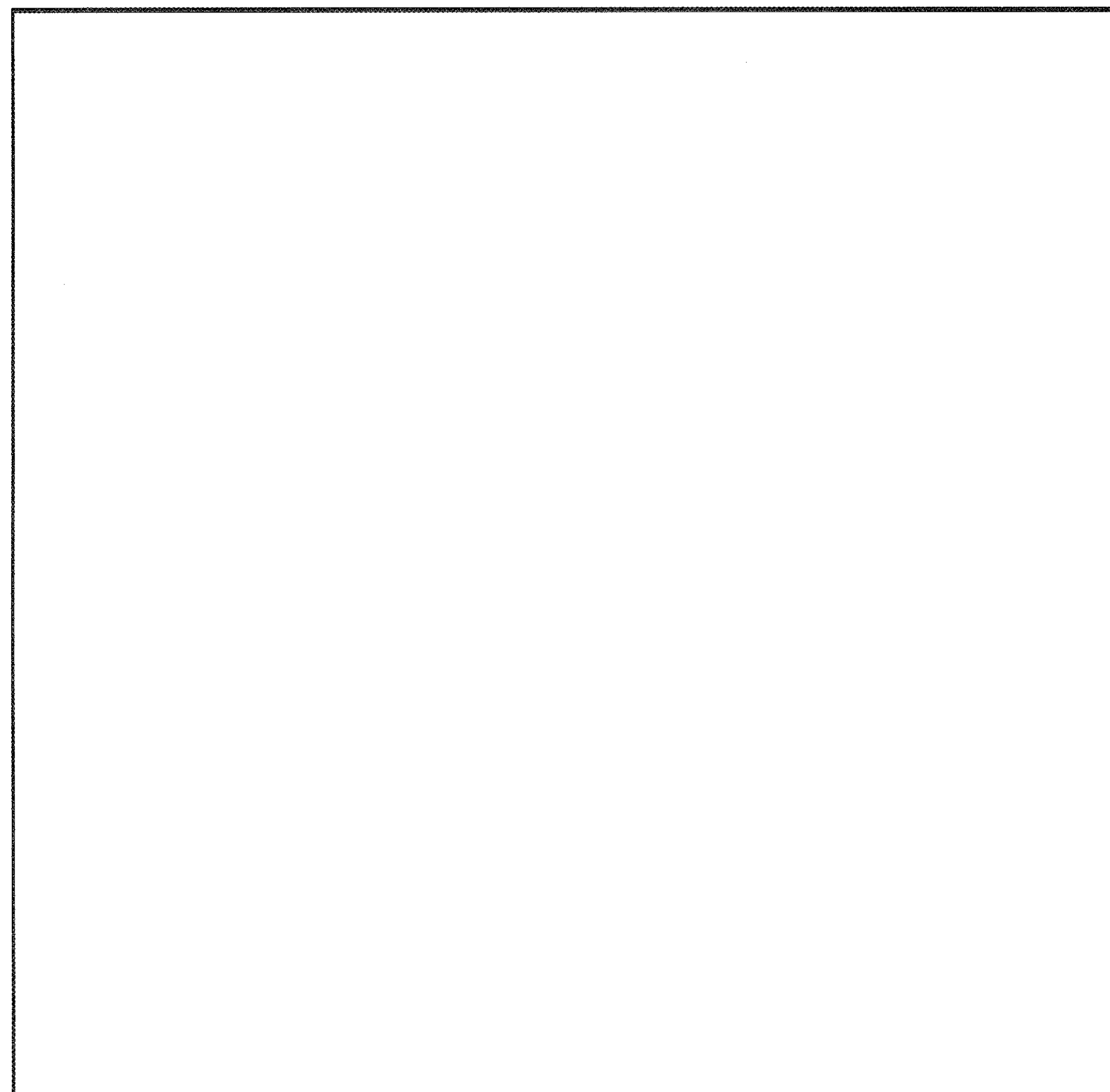

LITTLE
DIVERSIFIED ARCHITECTURAL CONSULTING

1300 Dove Street, Suite 100
Newport Beach, CA 92660
T: 949.698.1400 F: 949.698.1433
www.littleonline.com

This drawing and the design shown are the property of Little Diversified Architectural Consulting. The reproduction, copying or other use of this drawing without their written consent is prohibited and any infringement will be subject to legal action.

© Little 2016

**COMPTON
CCD**

CAMPUS PUBLIC SAFETY BUILDING

1111 EAST ARTESIA BOULEVARD,
COMPTON CALIFORNIA 90221

NOT USED - 12

CONCRETE BLOCK MINIMUM REINFORCING AT WALL OPENING NONE 6

CHORD BAR PLACEMENT NONE 3

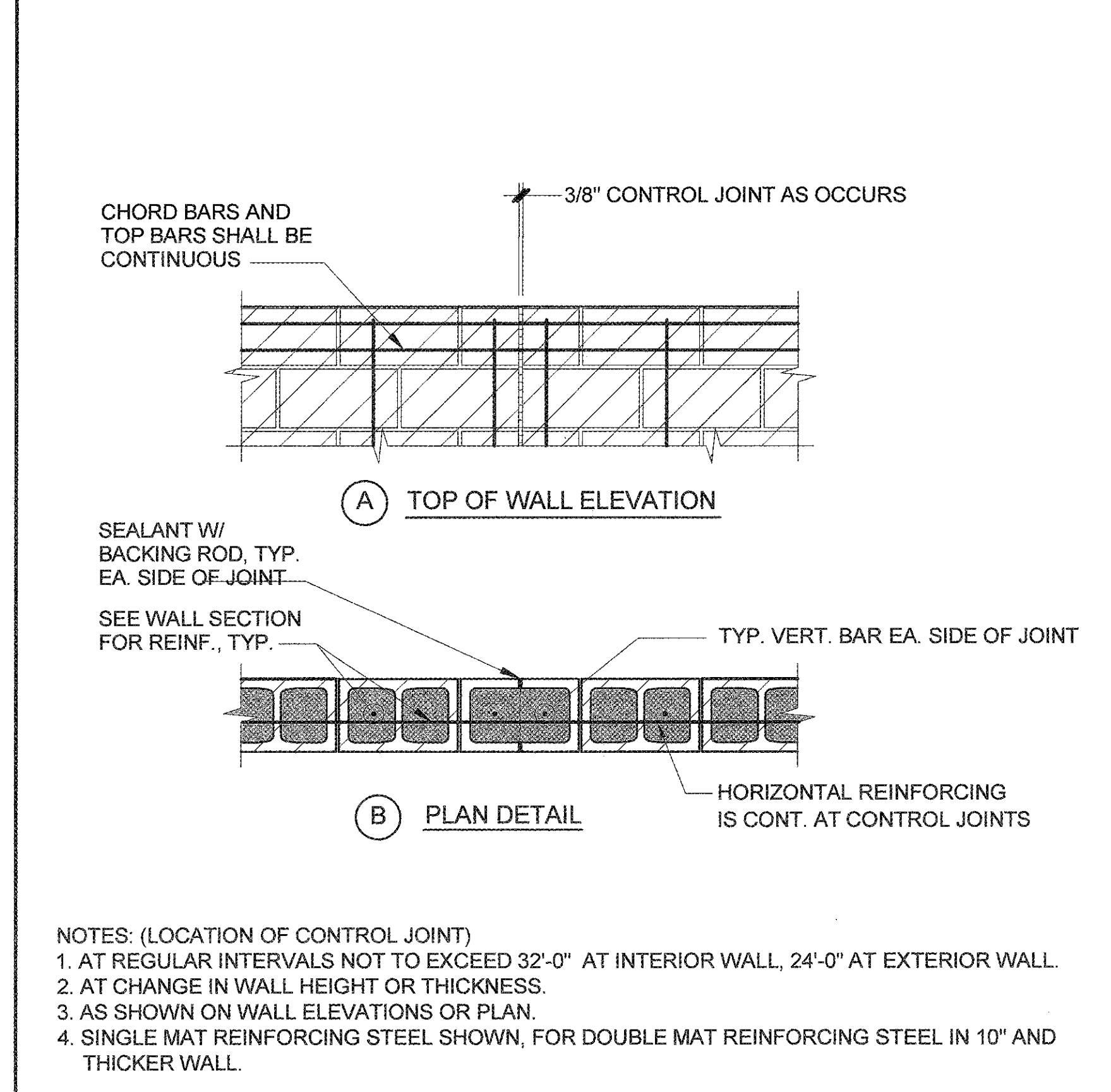
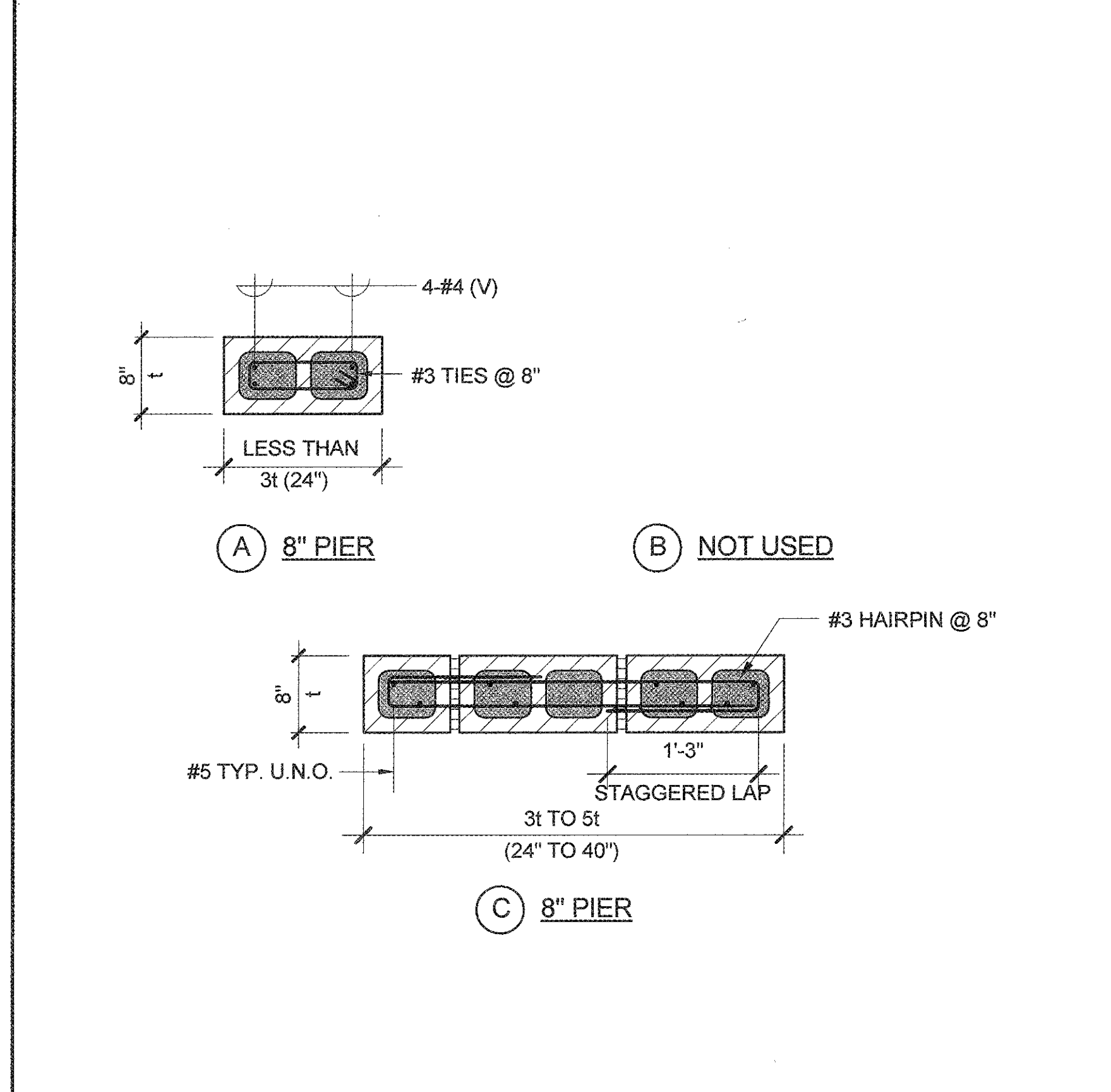
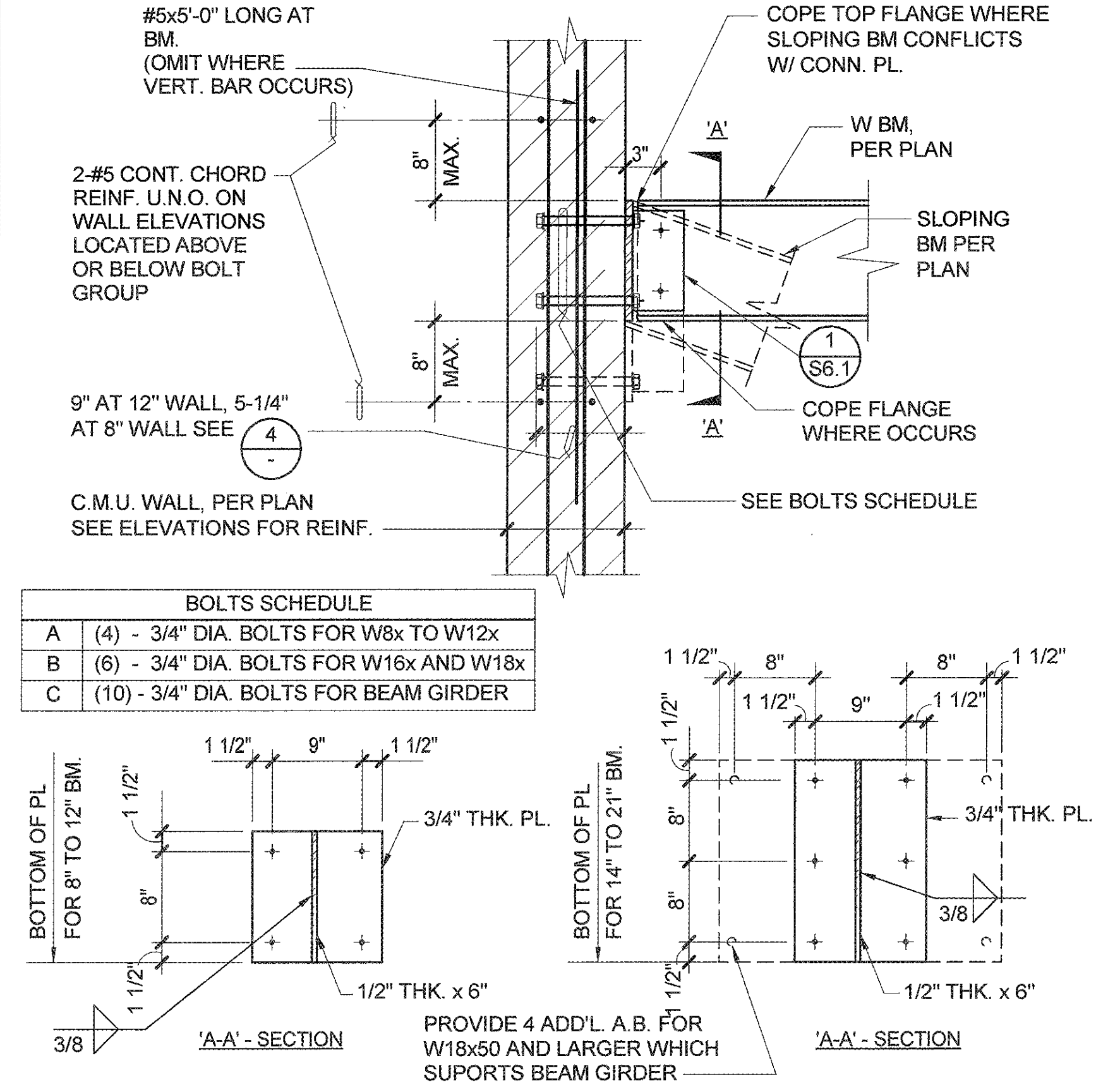
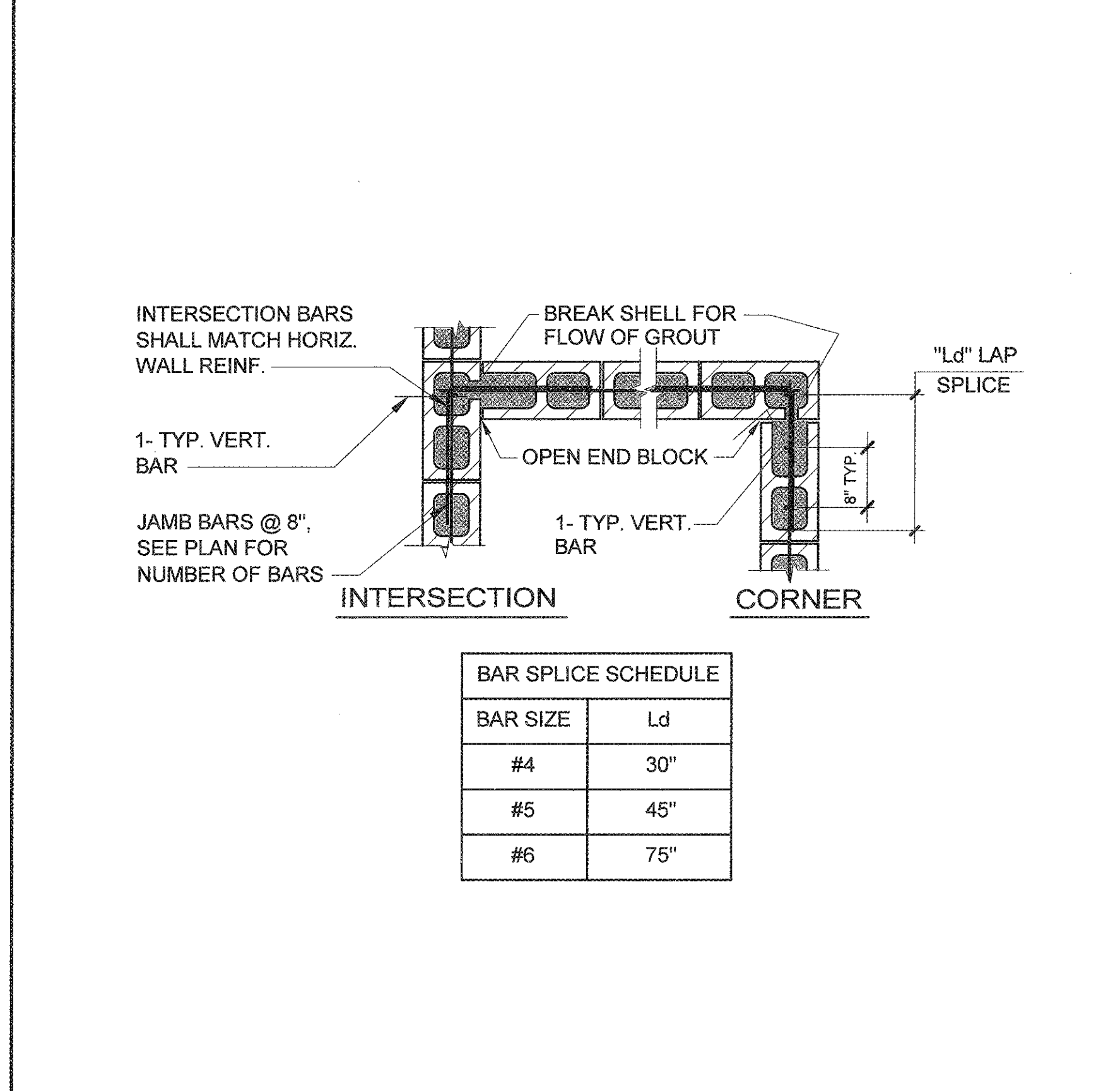

IDENTIFICATION STAMP
DIV. OF THE STATE ARCHITECT
OFFICE OF REGULATION SERVICES

FILE NO: 19-C1
AP: 03-117873
AC: [] FS: [] SS: []
DATE: DEC 12 2017

TTG
• STRUCTURAL
• MECHANICAL
• ELECTRICAL
• CIVIL

901 Via Piemonte Suite 400
Ontario, California 91764
Phone: 909.477.6815 Fax: 909.477.6916
www.ttgapp.com Project No. 0216.4877.00

REGISTERED PROFESSIONAL ENGINEER
No. S2292
No. 93292
STATE OF CALIFORNIA

PRINCIPAL IN CHARGE
RITA S. CARTER
PROJECT MANAGER
SHOJI TAKESHIMA / DAVID PHAN
DRAWN BY
GERARDO CARRANZA

NO.	REASON	DATE

REVISIONS

NO. 3034333

DATE: 11/21/17

SCALE: S5.1

CONCRETE BLOCK WALL INTERSECTION NONE 11

W BM CONNECTION AT CMU WALL NONE 8

REINFORCEMENT AT CONCRETE BLOCK PIER NONE 5

TYPICAL CONTROL JOINT DETAILS NONE 2

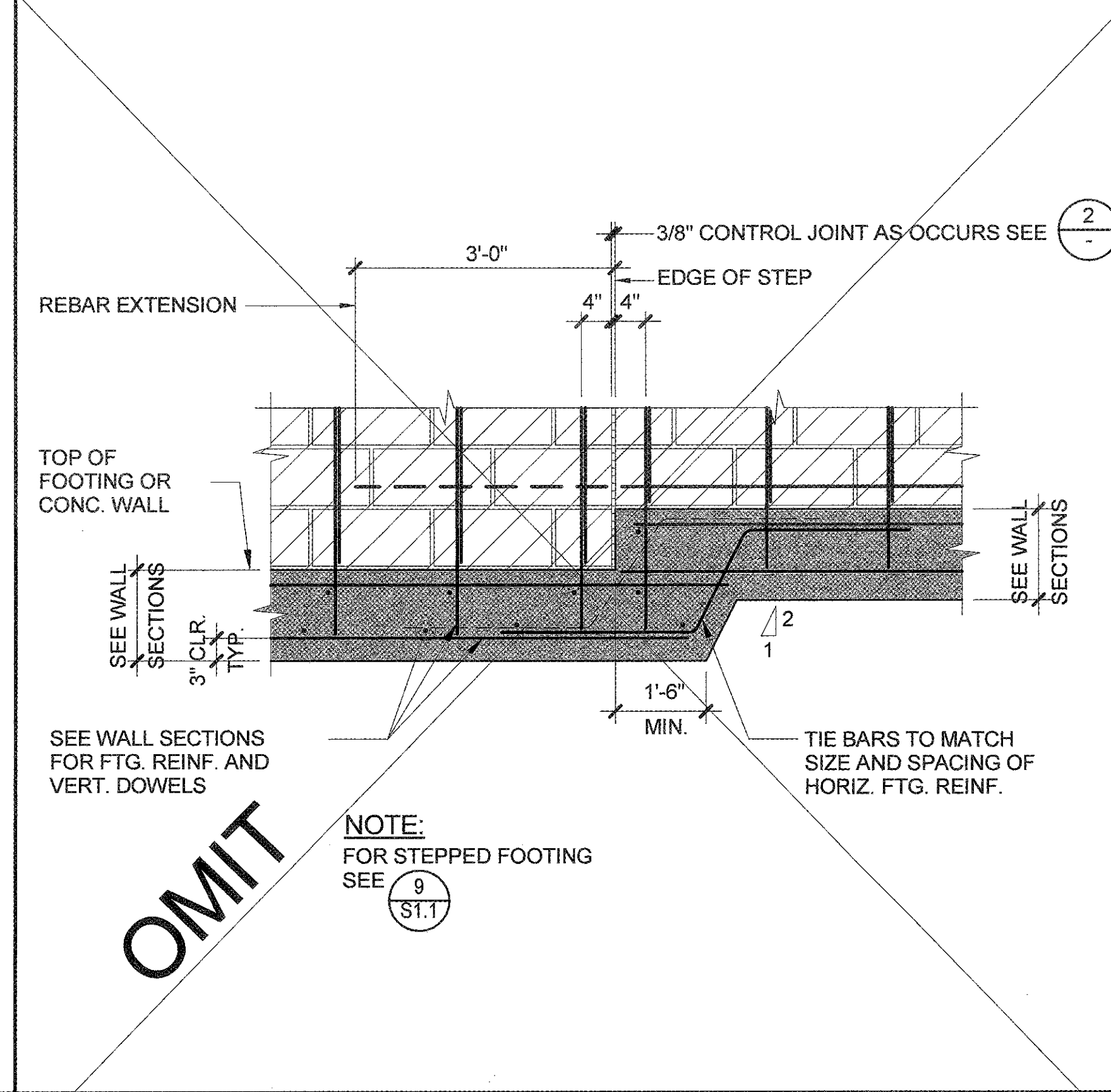
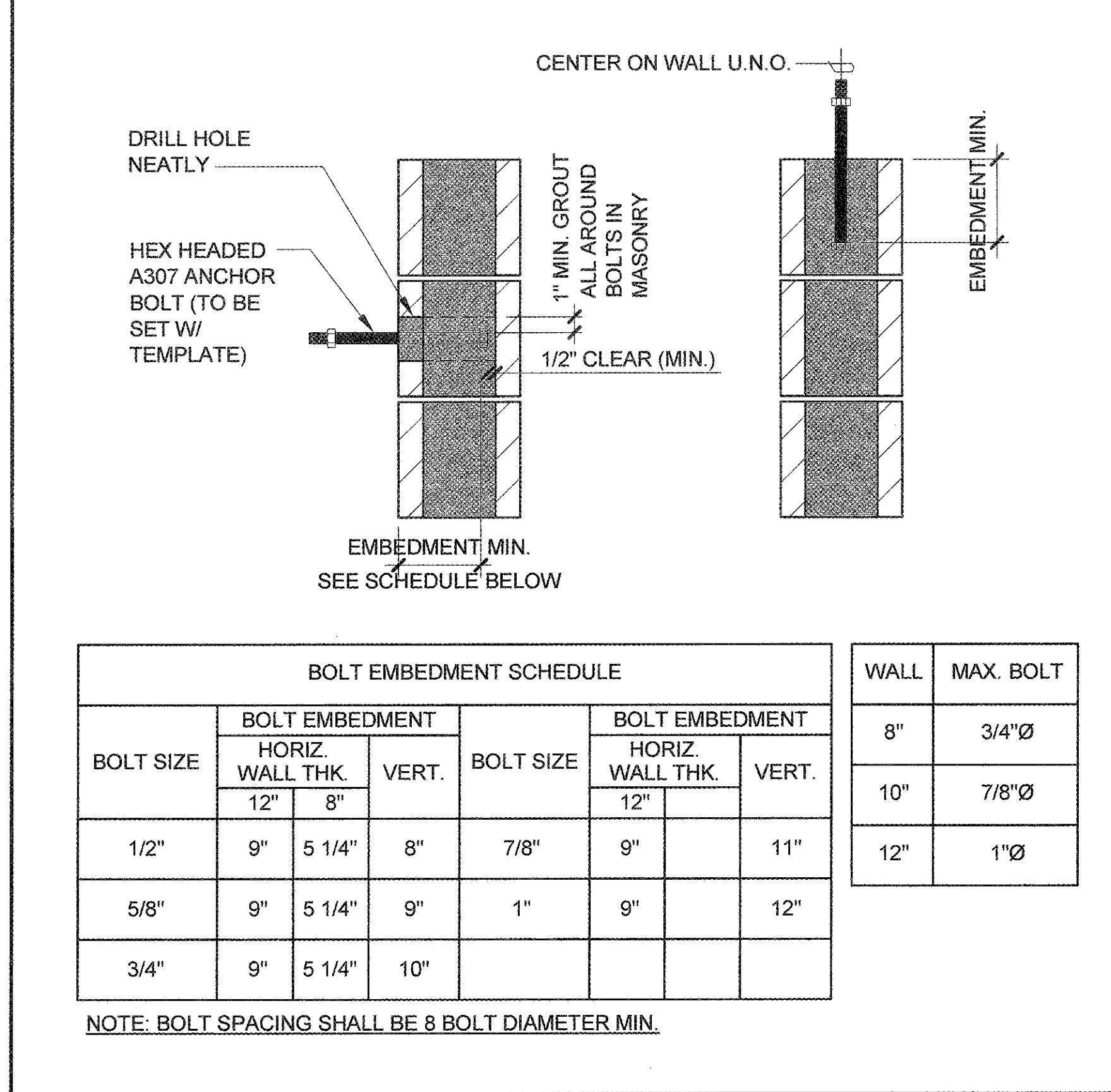
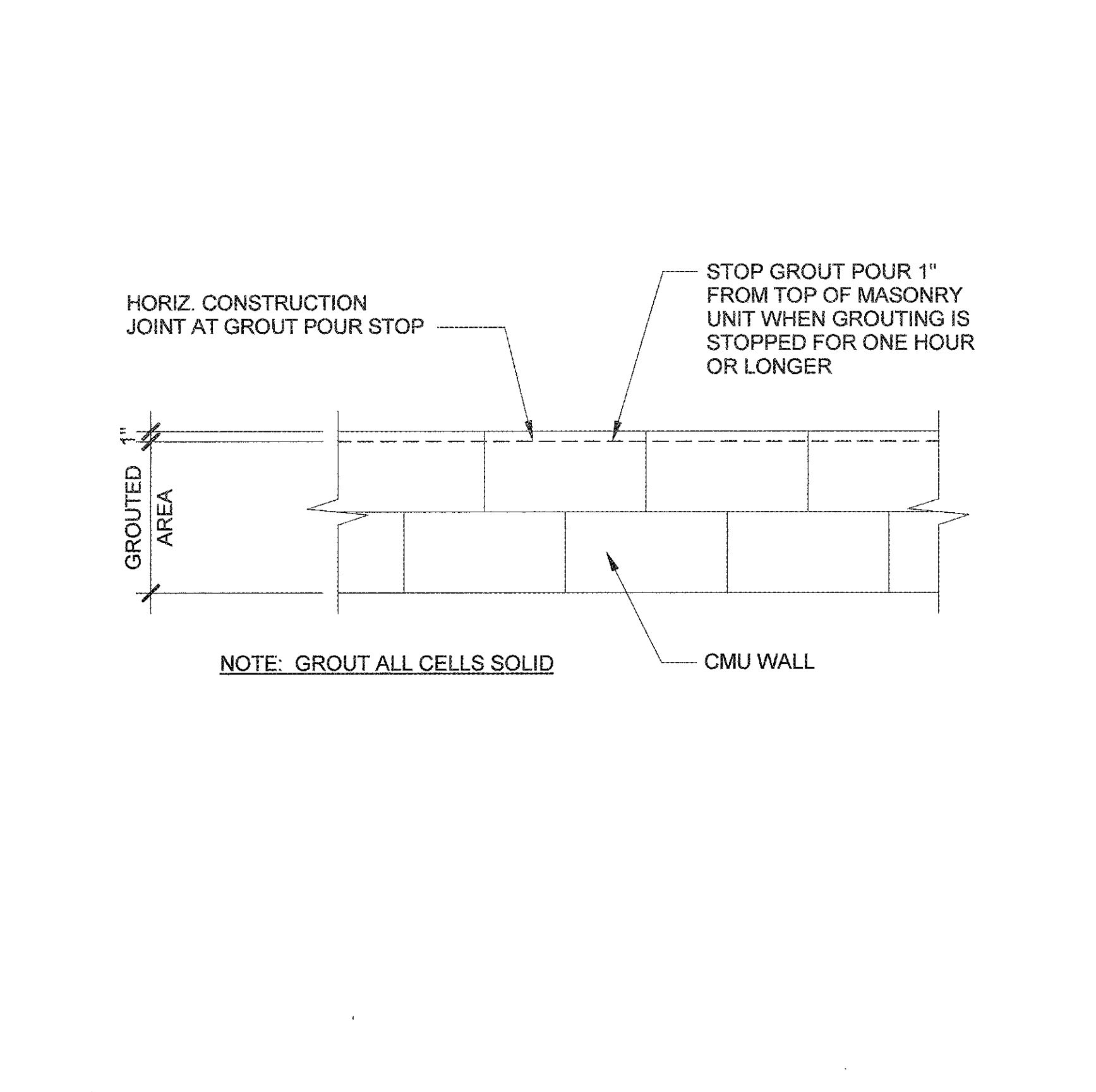
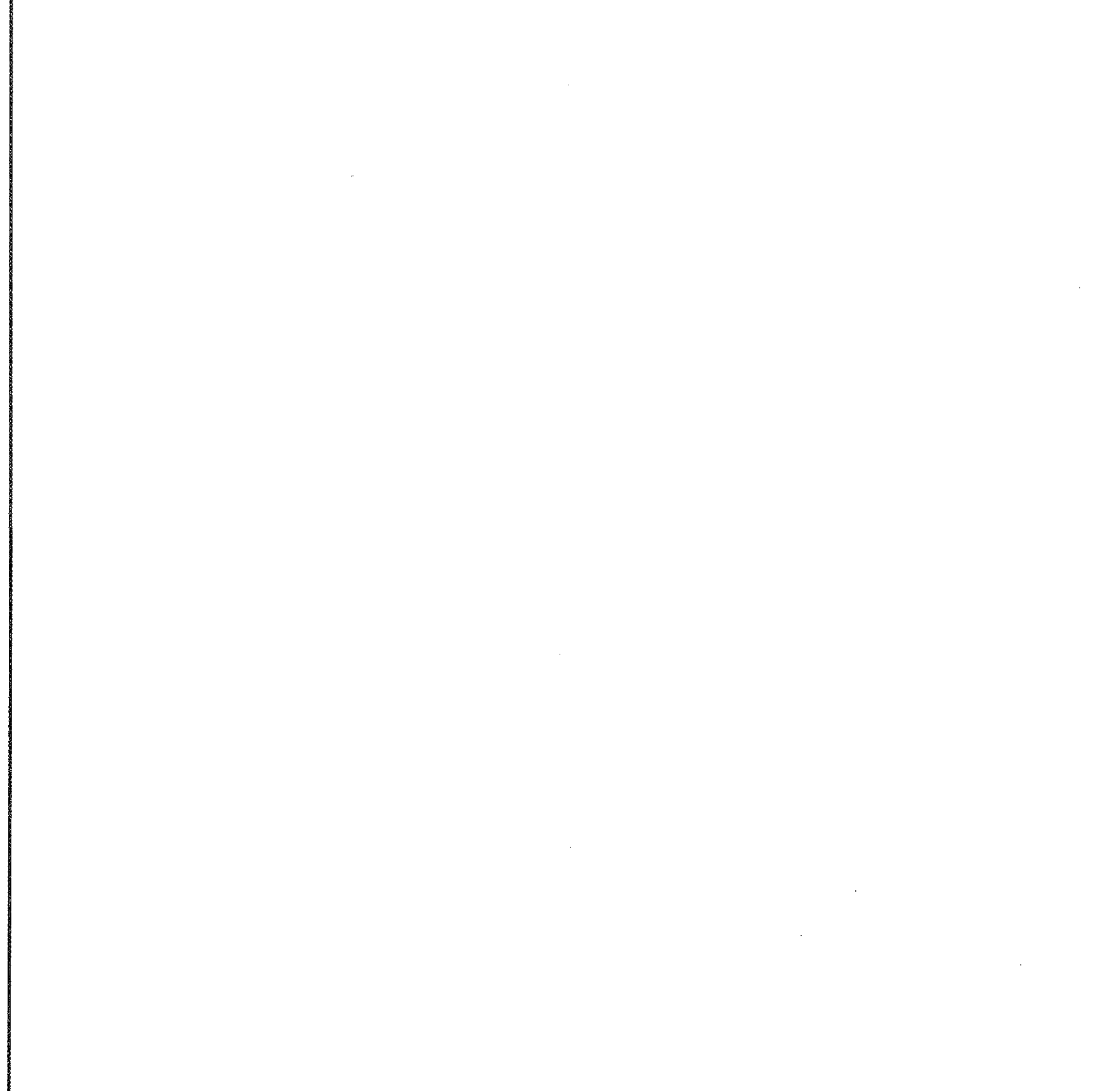

REVISIONS

NO. 3034333

DATE: 11/21/17

SCALE: S5.1

NOT USED - 10

TYP. CMU WALL CONSTRUCTION JOINT NONE 7

TYPICAL BOLT EMBEDMENT SCHEDULE NONE 4

CONTROL JOINT AT CHANGES IN TOP OF FTG. NONE 1

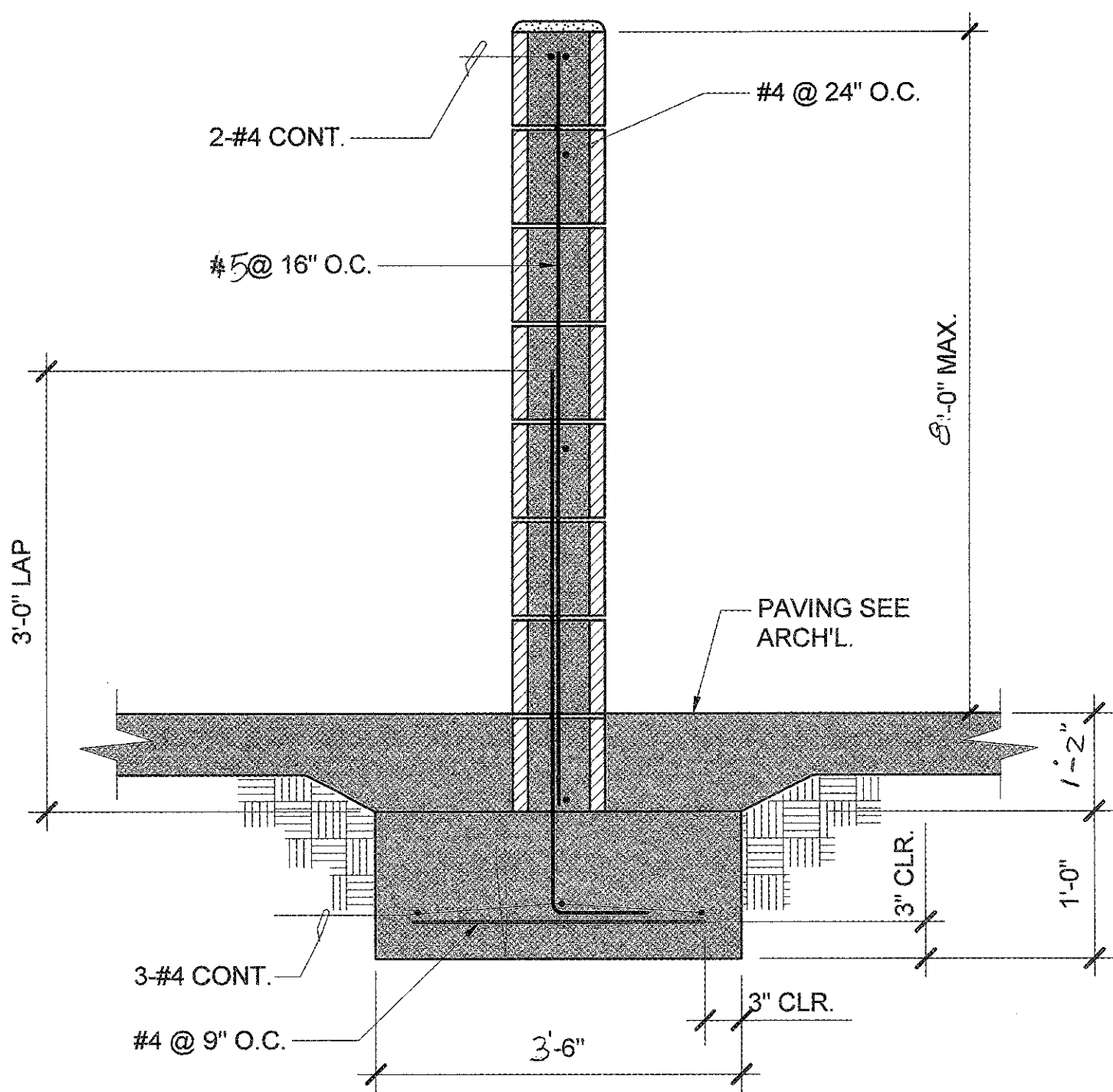

CMU WALL

NONE 12

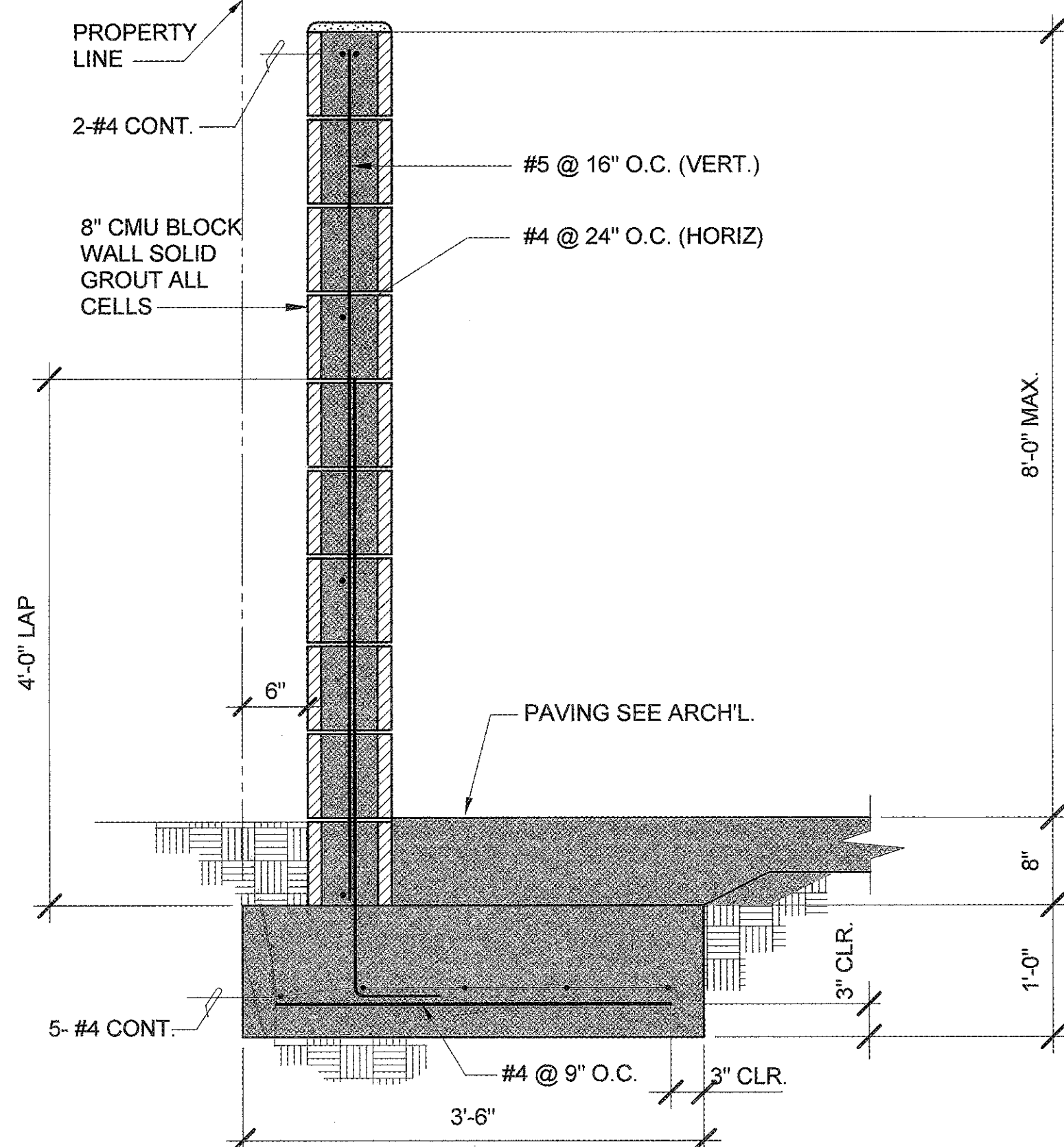

SITE CMU WALL

NONE 9

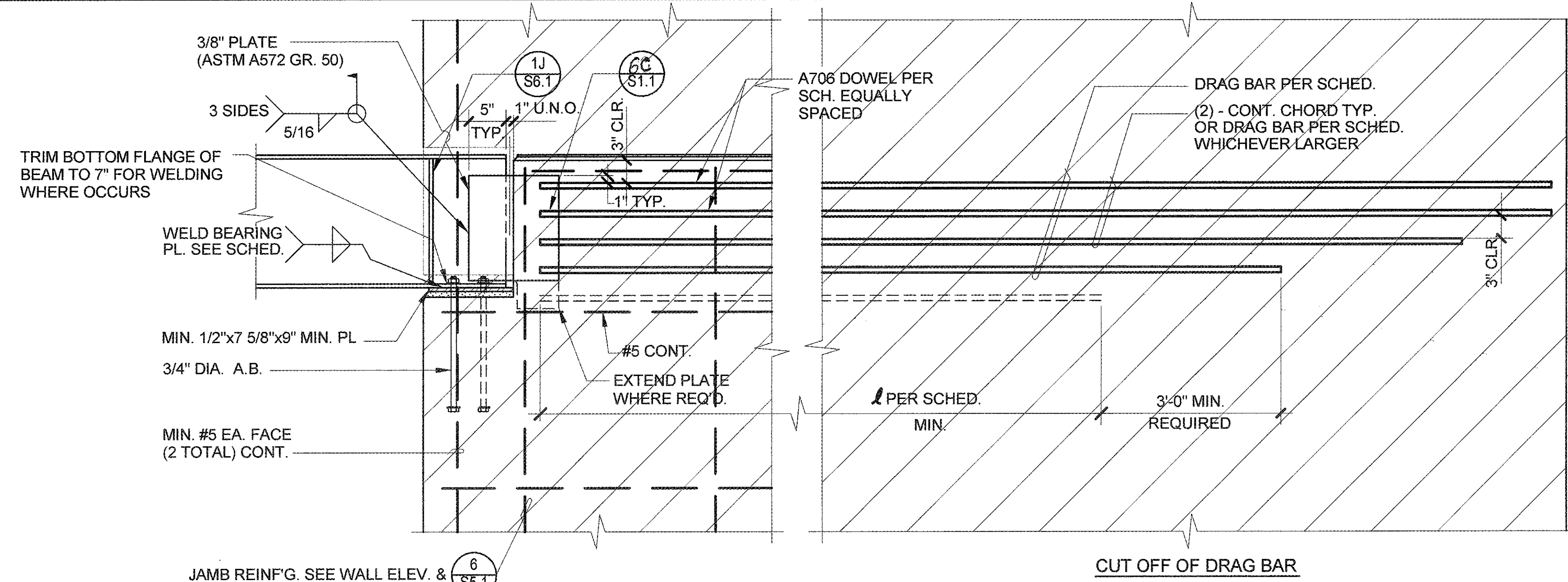

TYPICAL STEEL BEAM/CMU DRAG CONNECTION

NONE 3

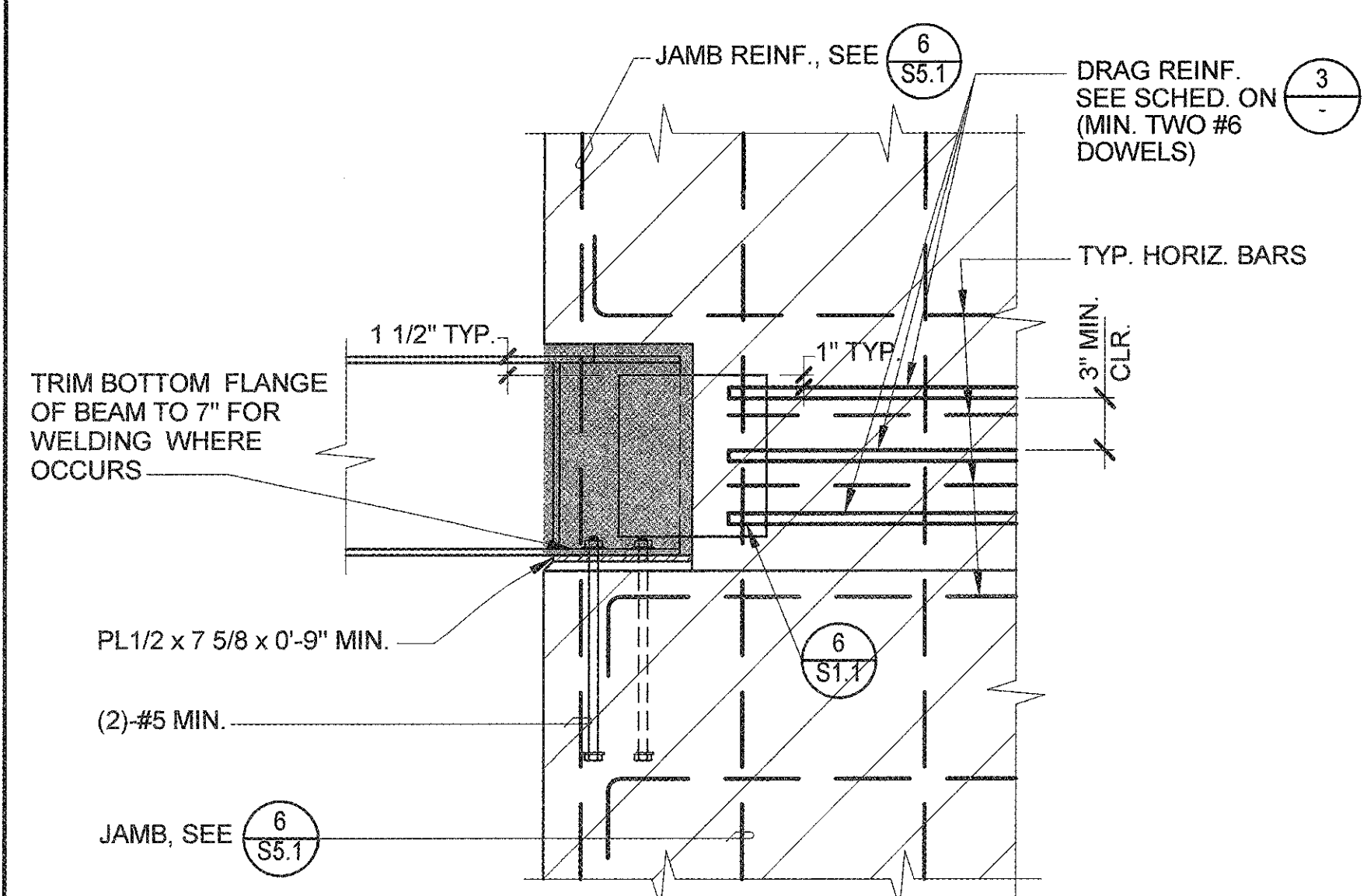

TYP. STEEL BEAM/CMU DRAG CONN.

NONE 11

NOT USED

NOT USED

HSS TO CMU WALL CONNECTION

NONE 2

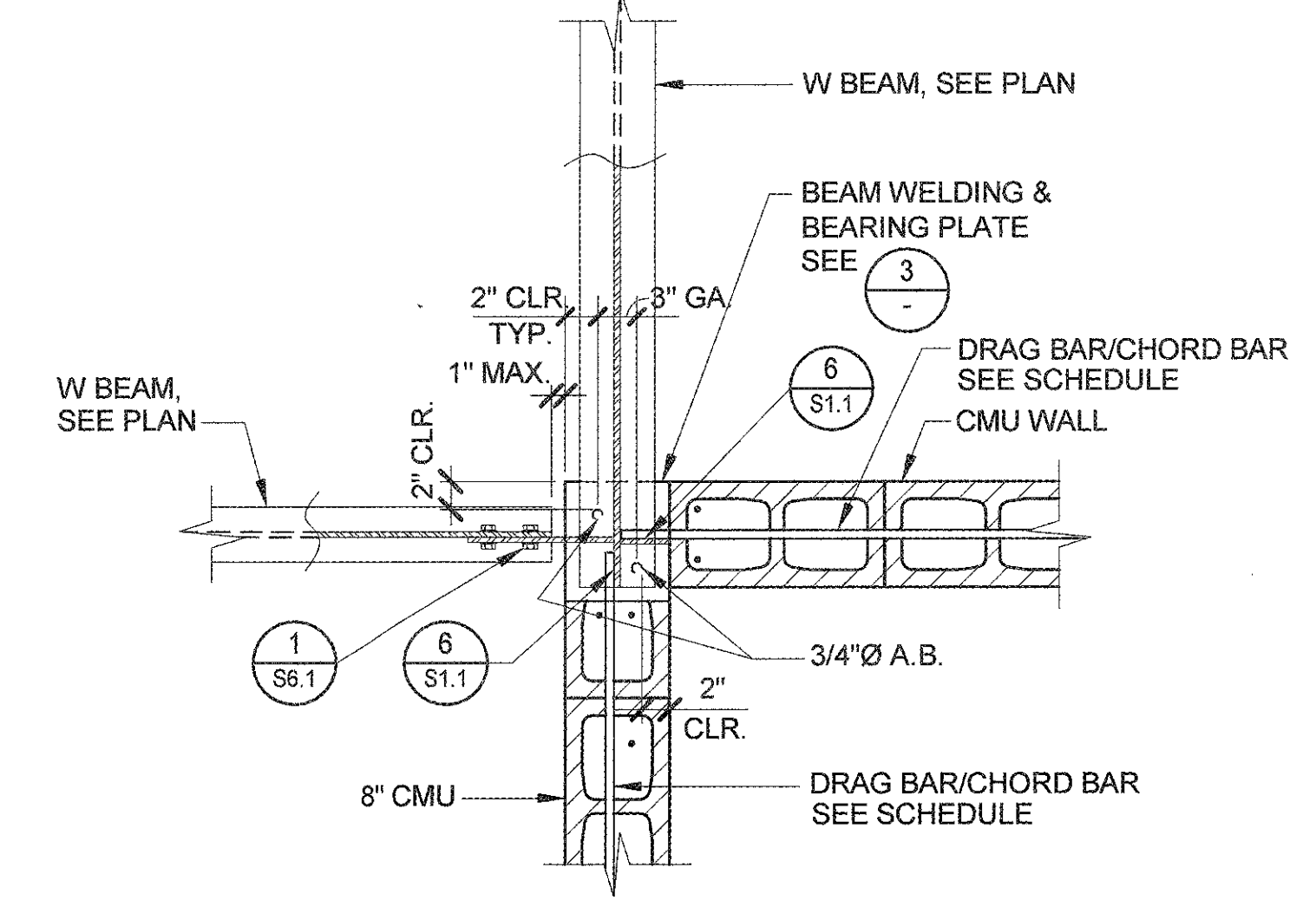

BEAM TO BEAM CONNECTION

NONE 10

NOT USED

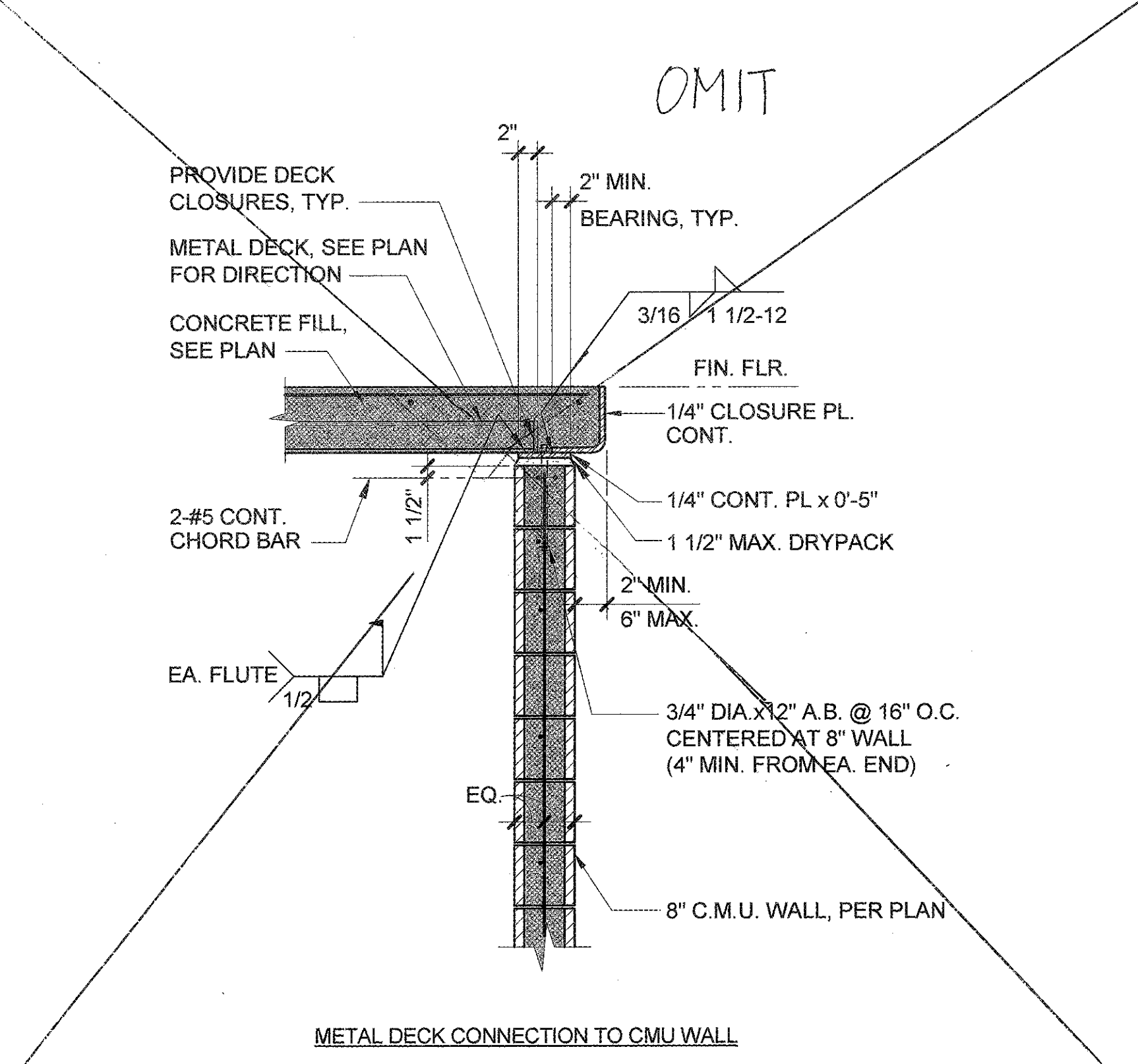

TYPICAL WALL SECTION

NONE 4

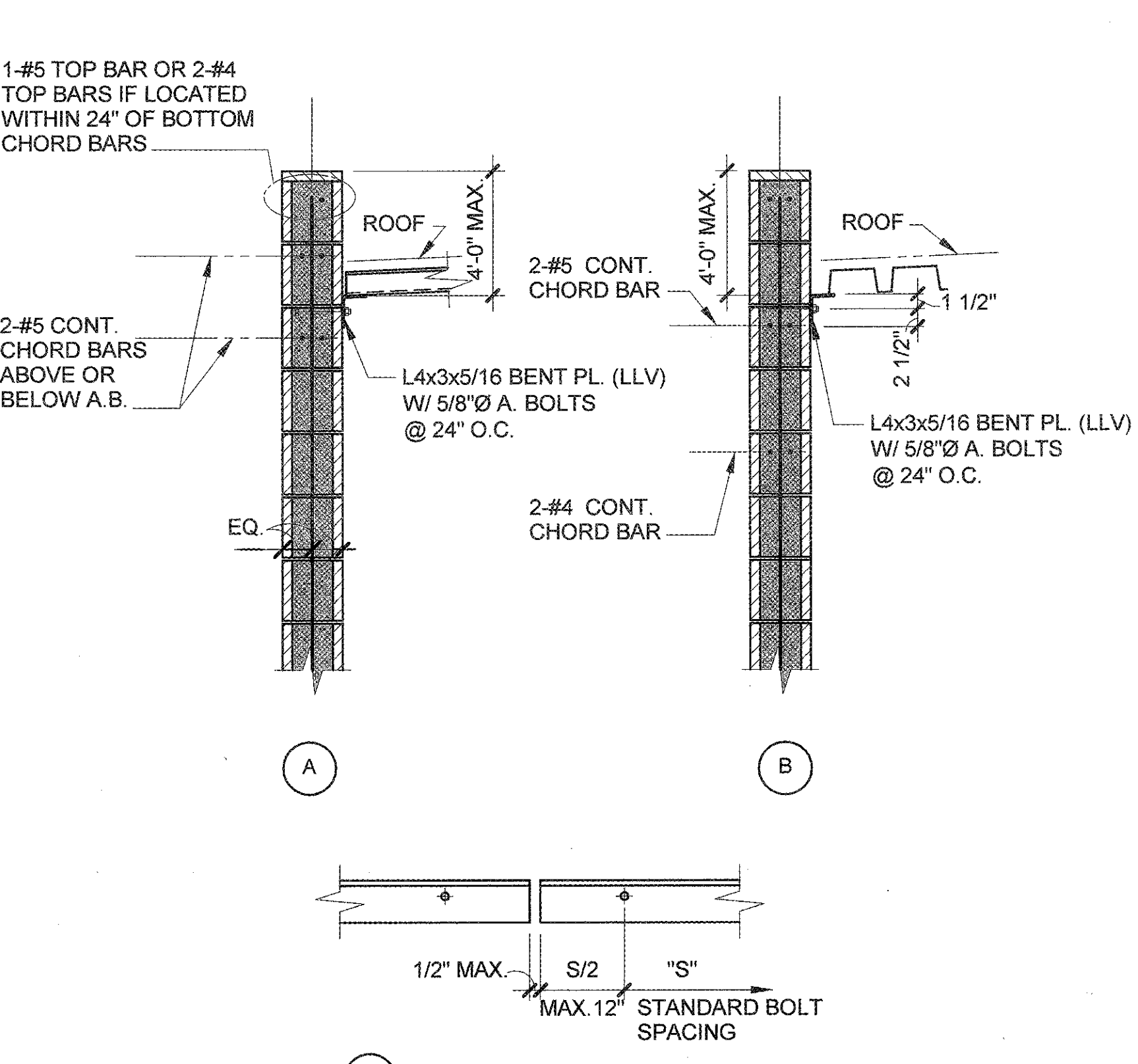

TYPICAL WALL SECTIONS

NONE 1

CONNECTION TYPE	A706 DOWEL (d)	BEARING PL. WELD
A	2 - #6 x 4'-6"	1/4" x 8"
B	3 - #6 x 4'-6"	1/4" x 8"
C	4 - #6 x 4'-6"	1/4" x 10"
D	5 - #6 x 4'-6"	1/4" x 10"

- NOTES:
 1. CENTER STEEL BEAM ON CMU WALL TYP. U.N.O.
 2. FOR MORE INFO. SEE DETAIL (11) & (10)

- NOTES:
 1. FOR INFORMATION NOT NOTED AND CONNECTION TYPE A,B,C, & D SEE (3) & (10)
 2. ADD SHIM PLATE BETWEEN SHEAR PLATE AND BEAM WEB AS REQ'D. MAINTAIN SAME WELDING BETWEEN SHIM PLATE AND BEAM WEB AS SHOWN.

- NOTE:
 1. FOR INFORMATION NOT NOTED SEE (3) & (11)
 2. ADD SHIM PLATE BETWEEN SHEAR PLATE AND BEAM WEB AS REQUIRED. MAINTAIN SAME WELDING BETWEEN SHIM PLATE AND BEAM WEB AS SHOWN.

NOT USED

- 12

NOT USED

- 9

NOT USED

- 6

NOT USED

- 3

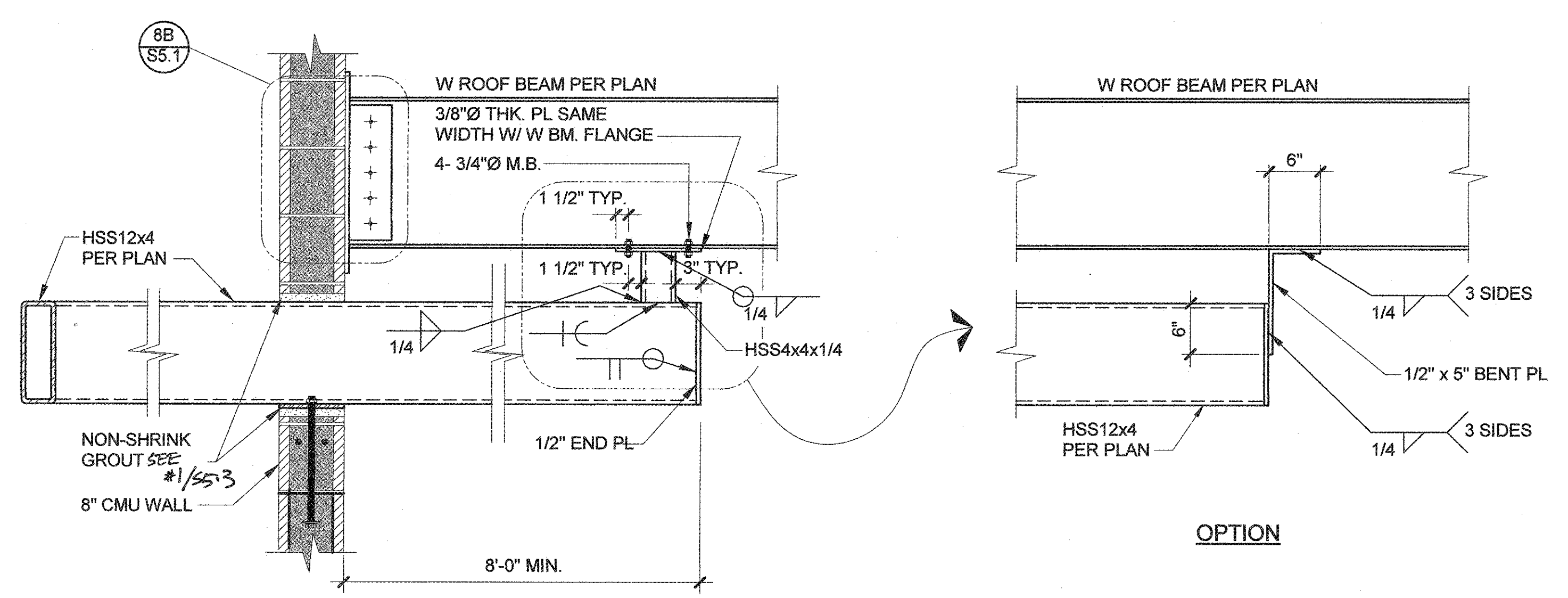

HSS TO W BEAM CONNECTION DETAIL

NONE 11

NOT USED

- 5

NOT USED

- 2

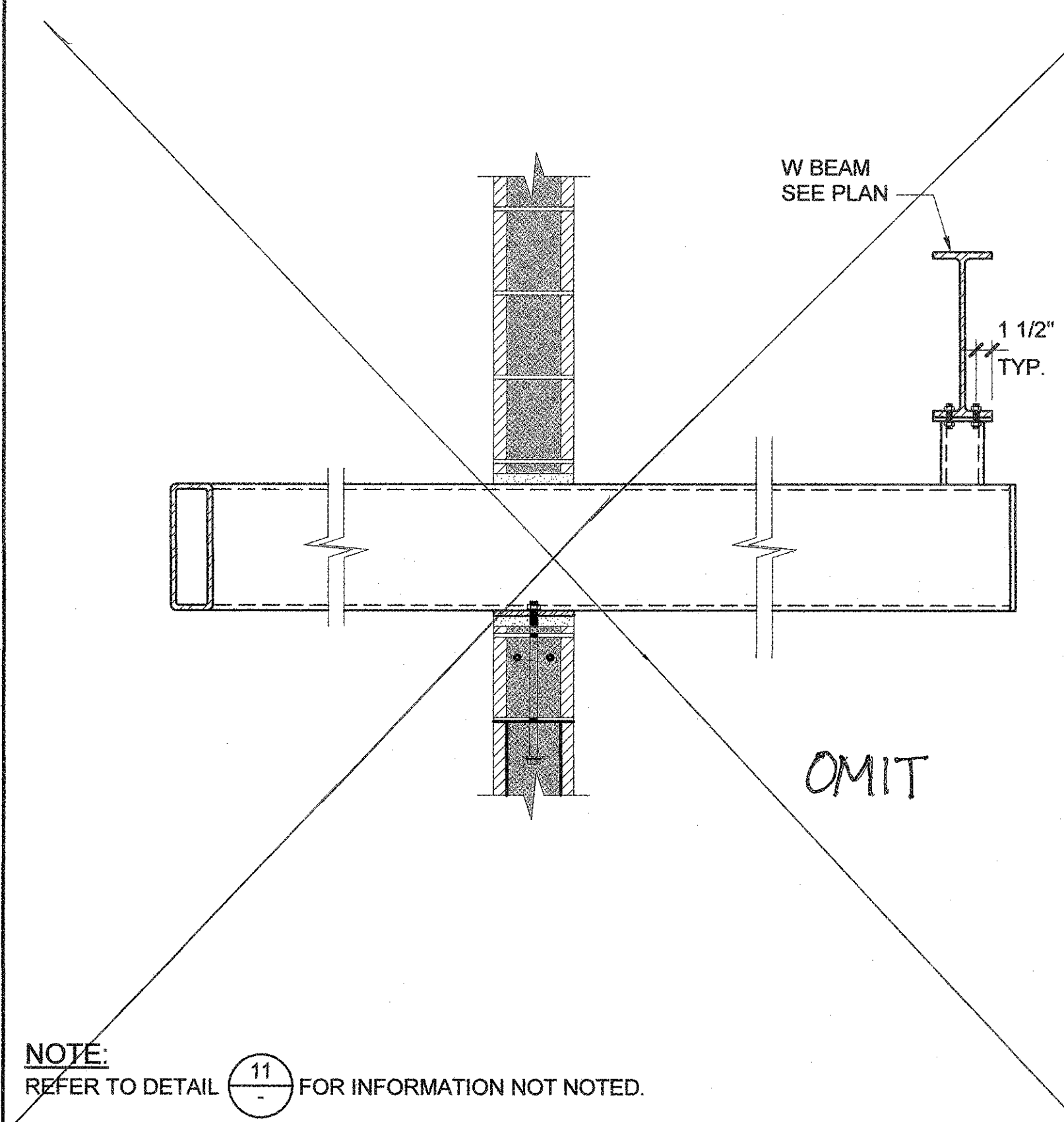

NOTE: REFER TO DETAIL 11 FOR INFORMATION NOT NOTED.

HSS TO W BEAM CONN. DETAIL

NONE 7

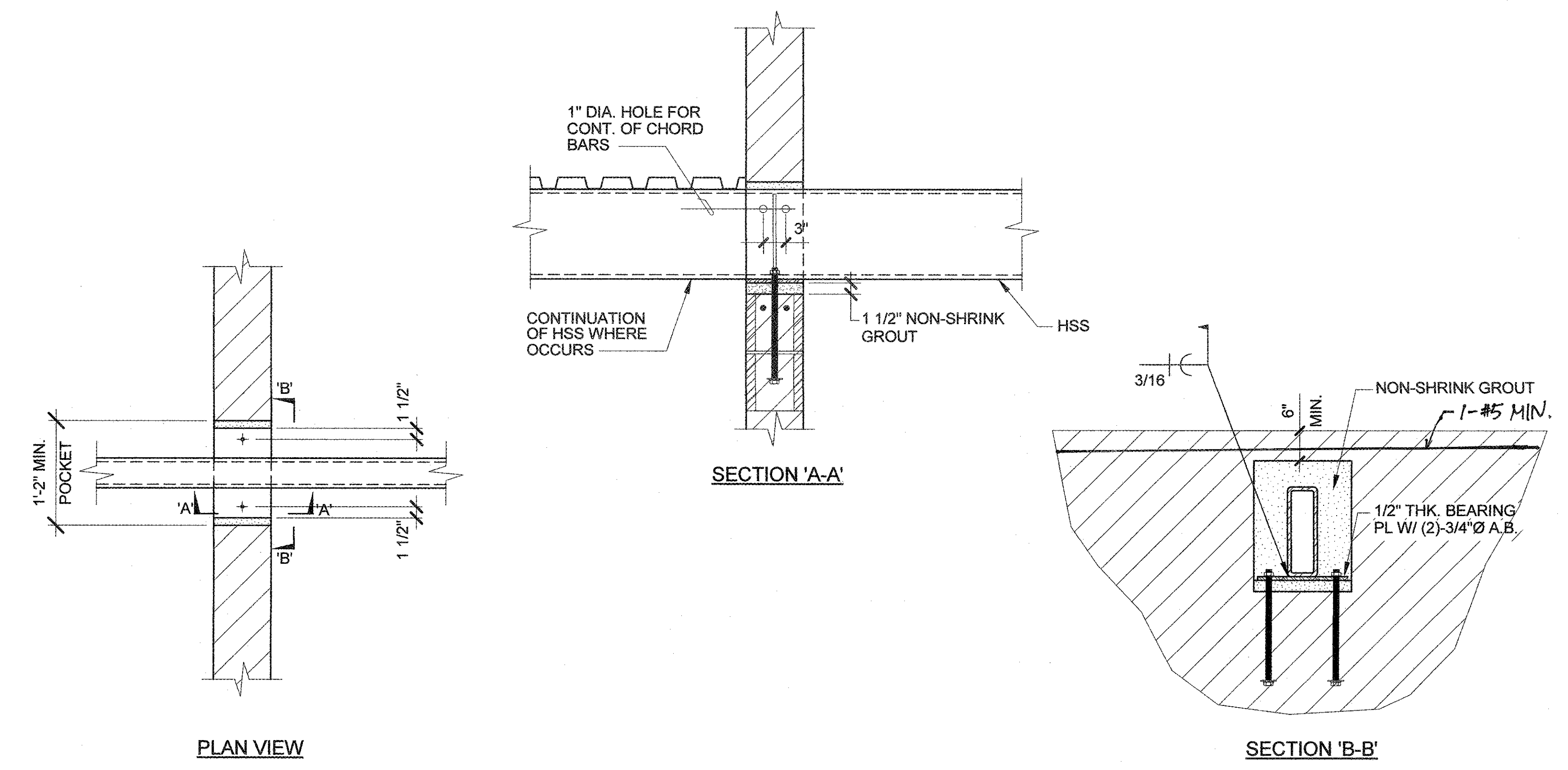

BEAM CONNECTION TO CMU WALL

NONE 1

NOT USED

- 10

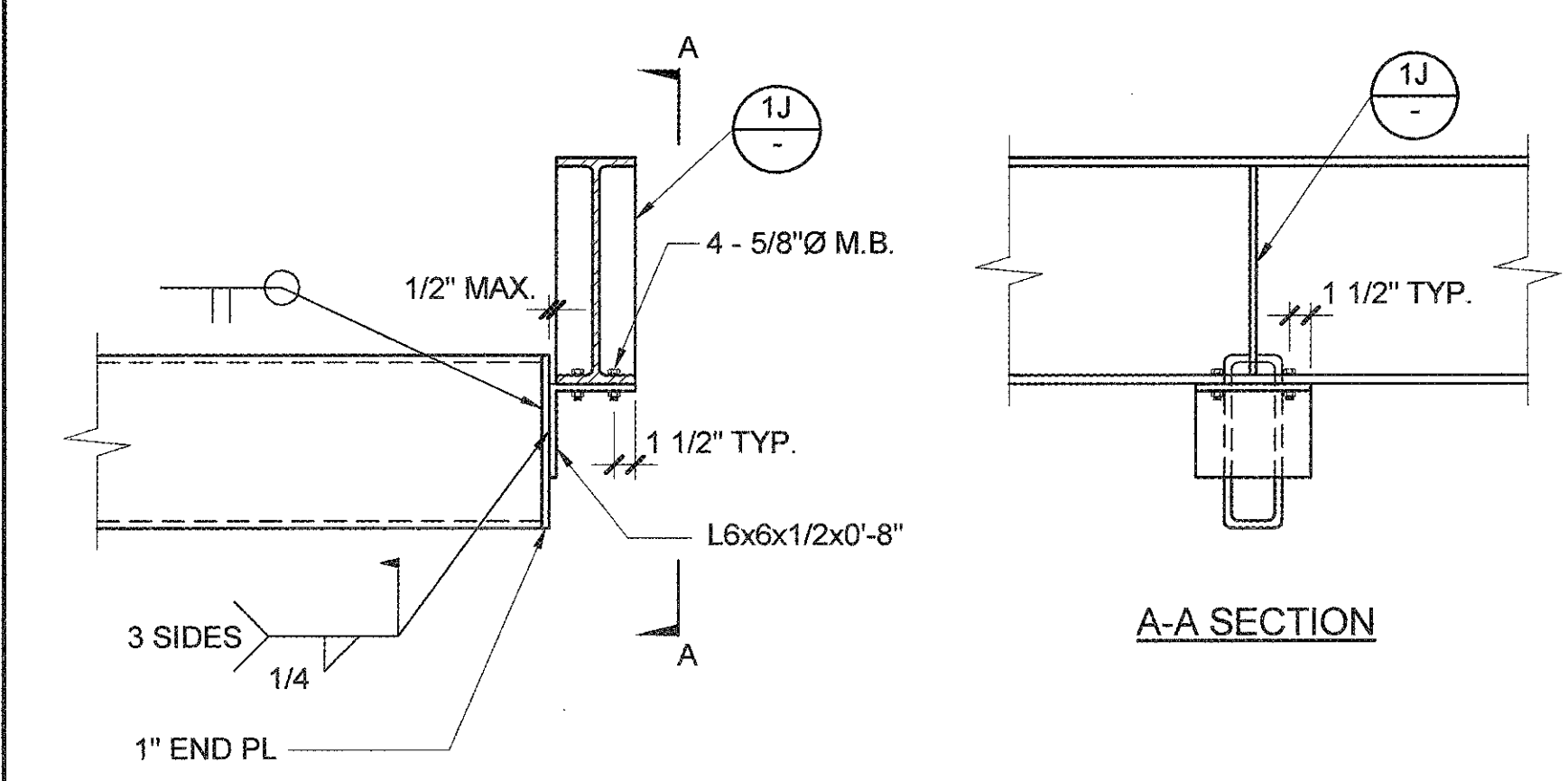

NOT USED - 12

NOT USED - 9

NOT USED - 6

CONNECTION DETAIL NONE 3

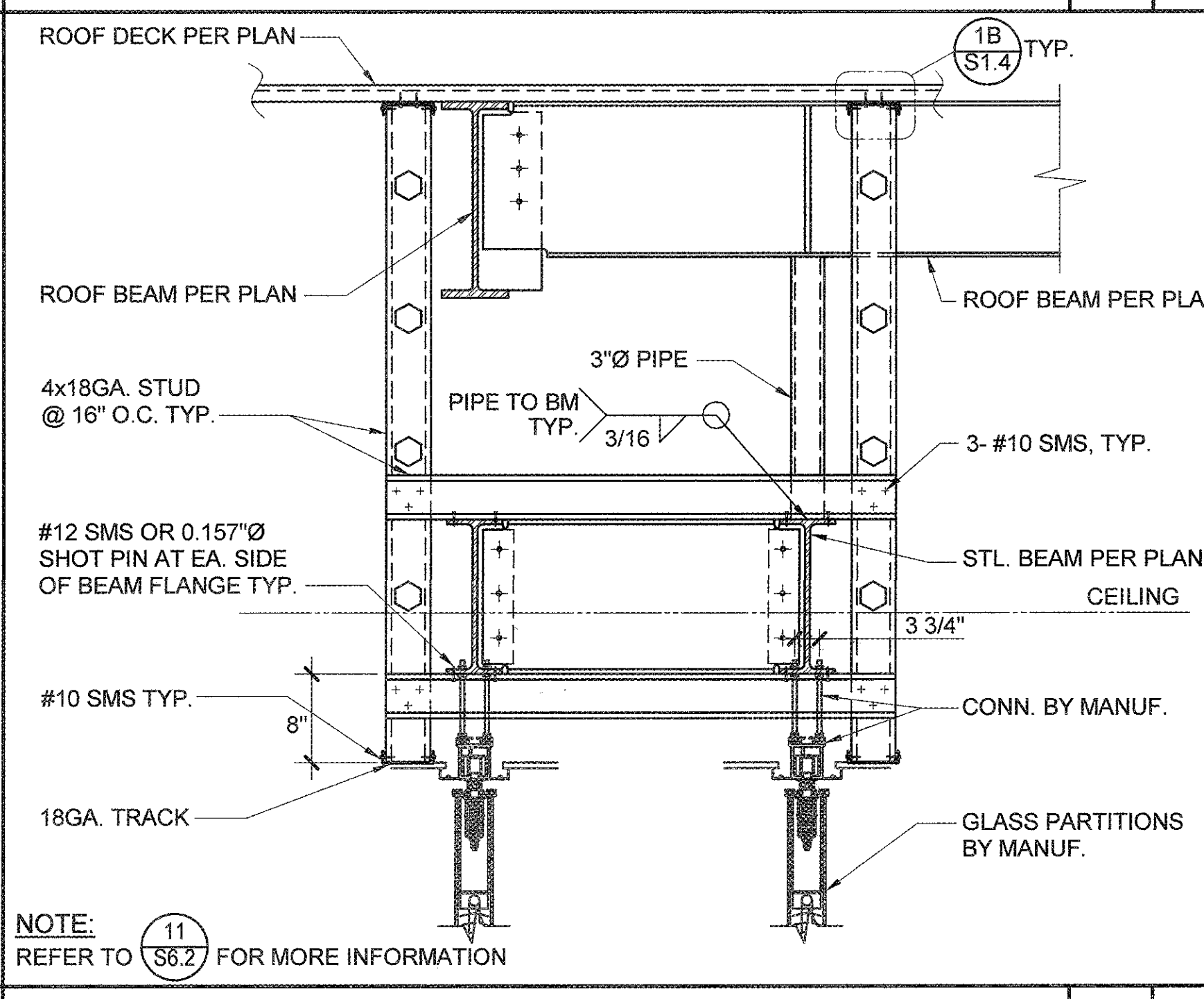
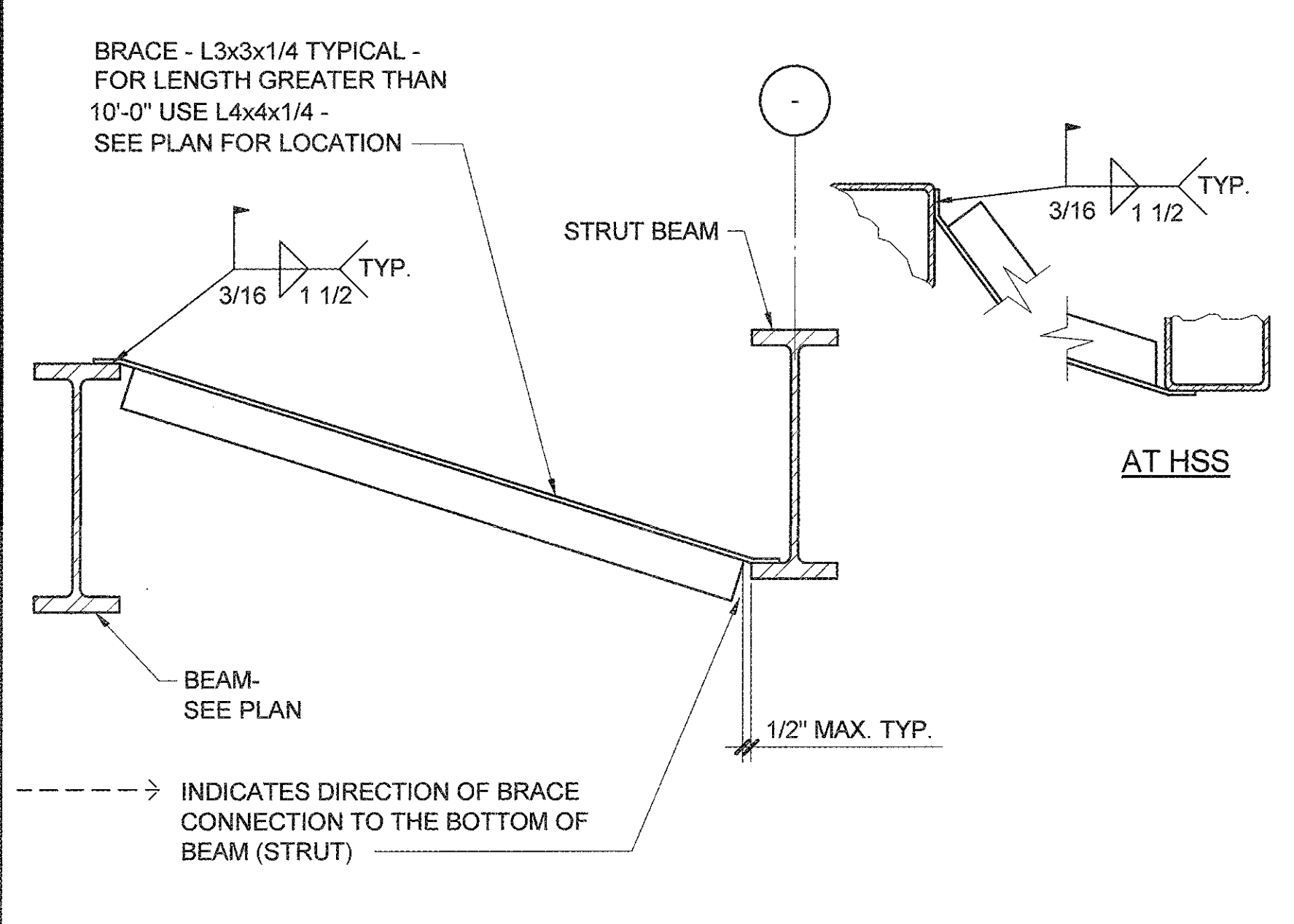

NOT USED - 11

NOT USED - 8

TYP. BRACED BEAM CONNECTION NONE 5

CONNECTION AT GLASS PARTITION NONE 2

TYP. BEAM CONNECTION SCHEDULE**

BEAM SIZE	CONNECTION PLATE THK.	CONNECTION PLATE WELD	NO. OF BOLTS	BOLT SIZE (SC) BOLTS
C8, W6, W8, W10	3/8"	1/4"	2	1" DIA. H.S.B.
C OR MC12 W12, W14	3/8"	5/16"	3	1" DIA. H.S.B.
W 16	3/8"	5/16"	4	1" DIA. H.S.B.
W 18	1/2"	3/8"	5	1" DIA. H.S.B.
W 21	1/2"	3/8"	6	1" DIA. H.S.B.
W 24	1/2"	3/8"	7	1" DIA. H.S.B.

- ** NOTE:
- WHERE CONNECTION PLATE IS NOT PERPENDICULAR TO BEAM OR COLUMN WEB OR FLANGES USE COMPLETE PENETRATION BEVEL WELD. SEE 1G
 - WHERE NUMBER OF BOLTS NOTED IN SCHEDULE CANNOT BE IN A SINGLE ROW, ADD SECOND ROW WITH TWO BOLTS MIN.
 - STIFF. PL. THK. WHERE NOT SPECIFIED SHALL BE SAME THK. AS CONN. PL. TYP. U.N.O.
 - ALL BOLTS ARE HSB, (A325 SC, LSL HOLE IN HORIZONTAL DIRECTION)
 - FOR ALL CONDITION "E", "K", & "L" SHOWN USE 2 ROWS OF BOLTS, IF REQUIRED SPACING NOT AVAILABLE AS SHOWN ON "C".

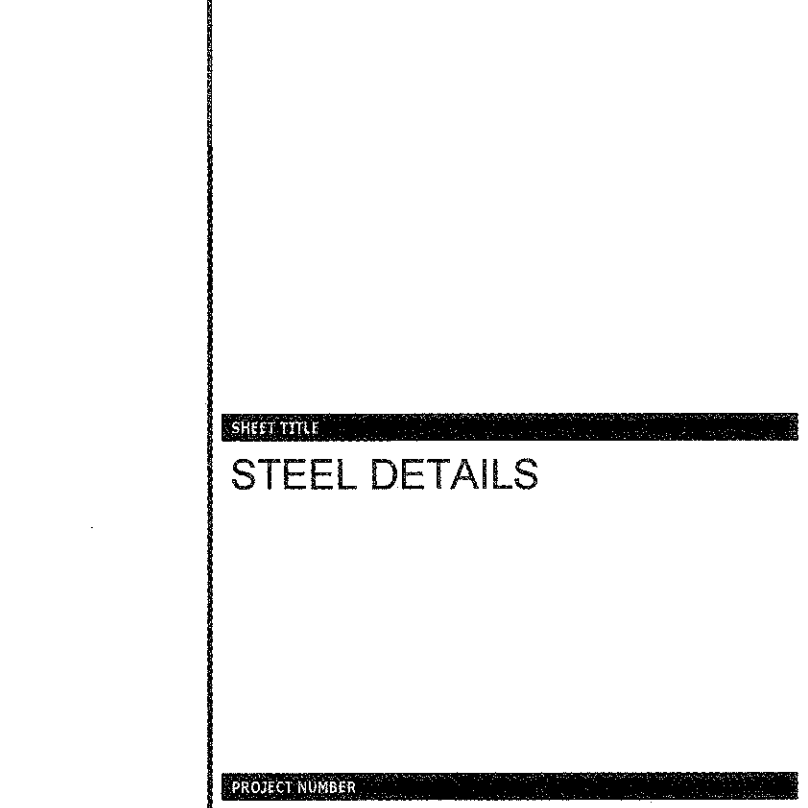
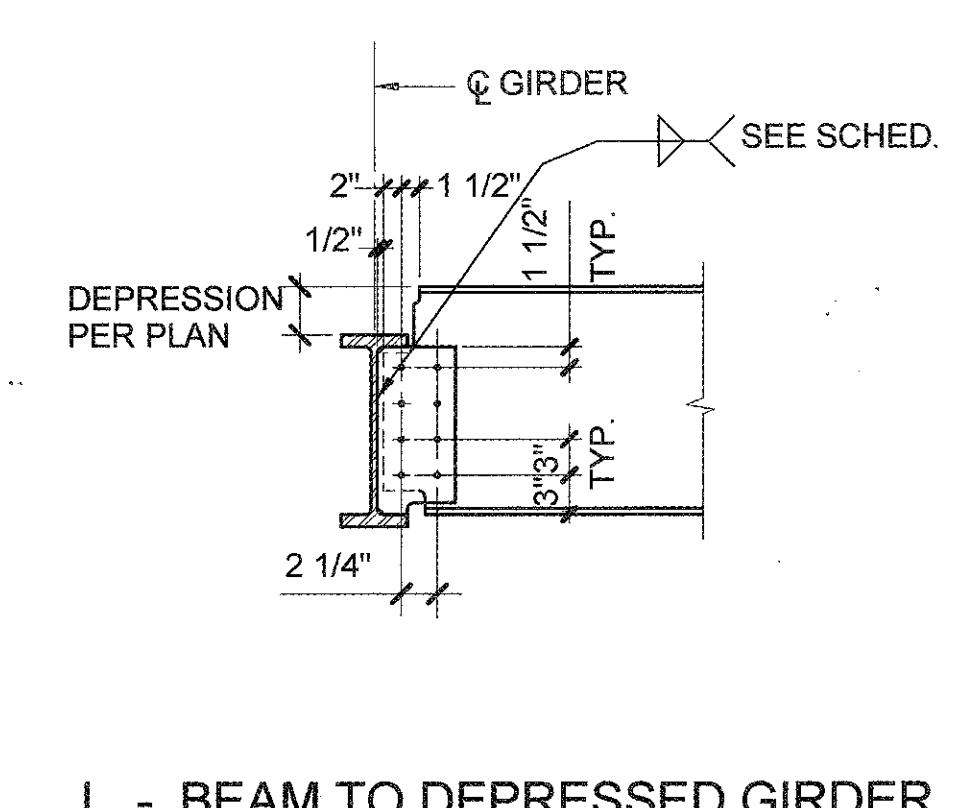
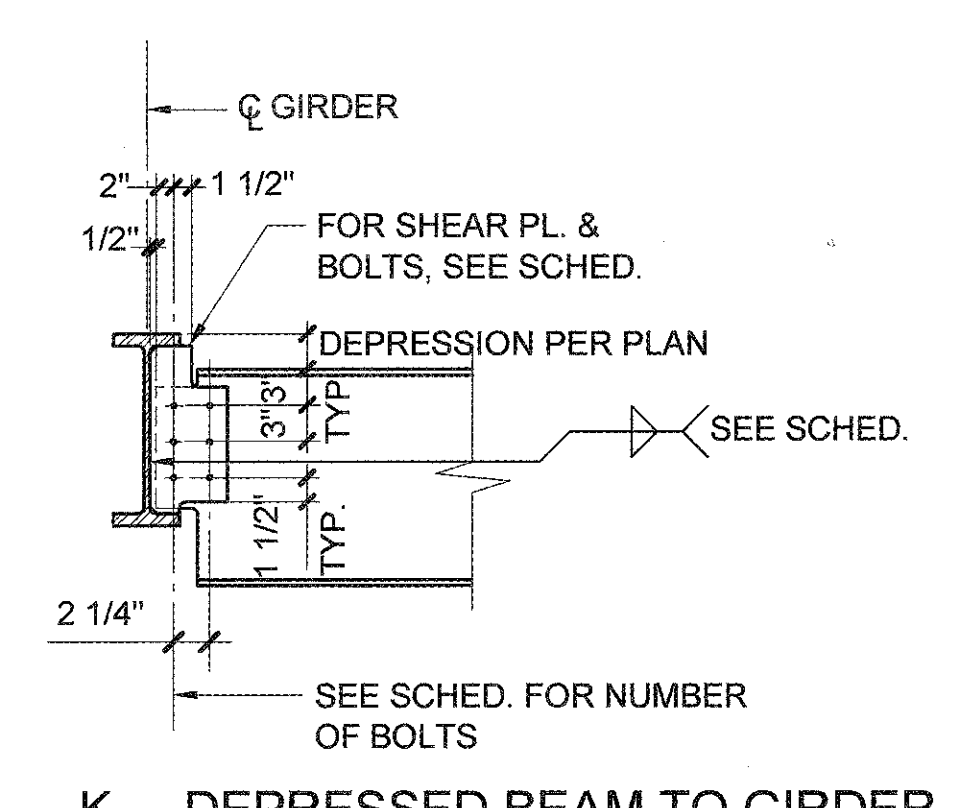
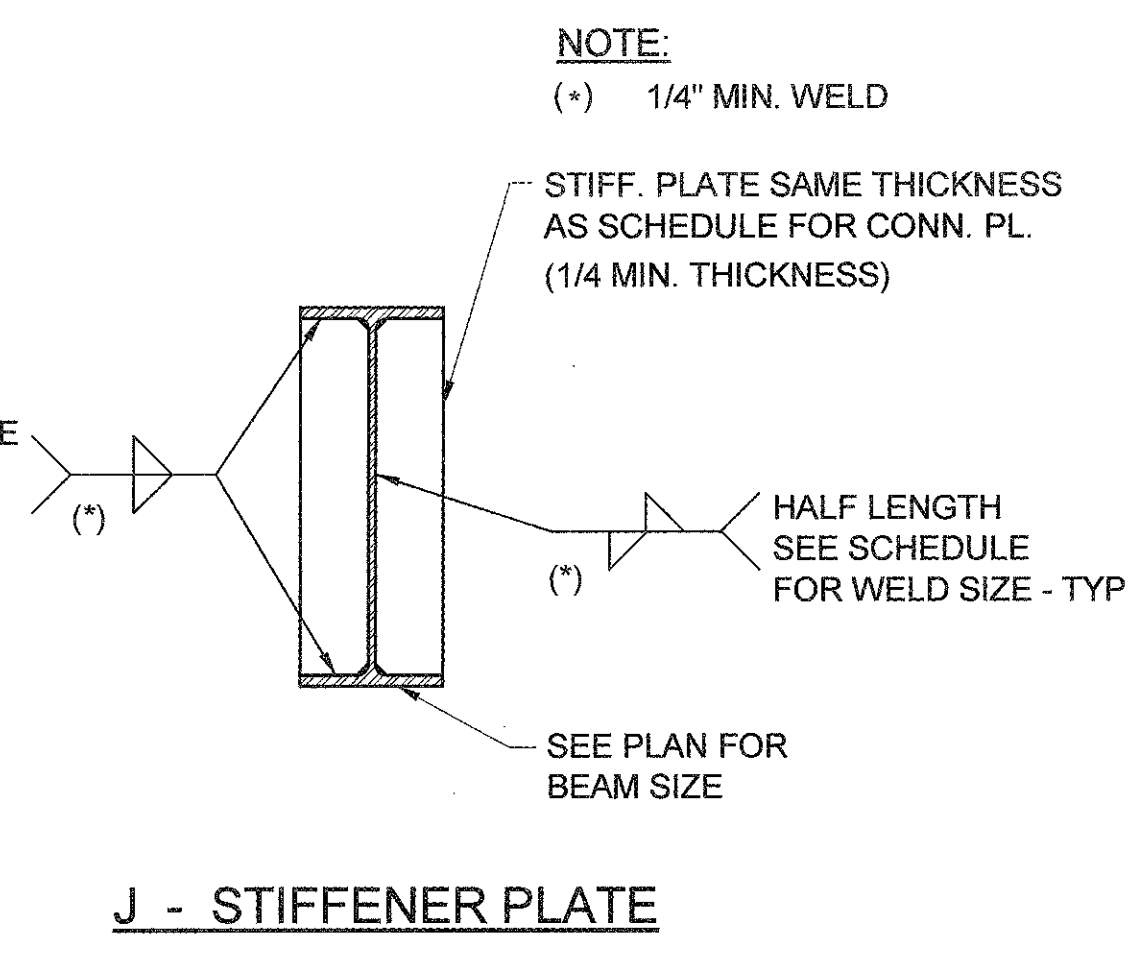
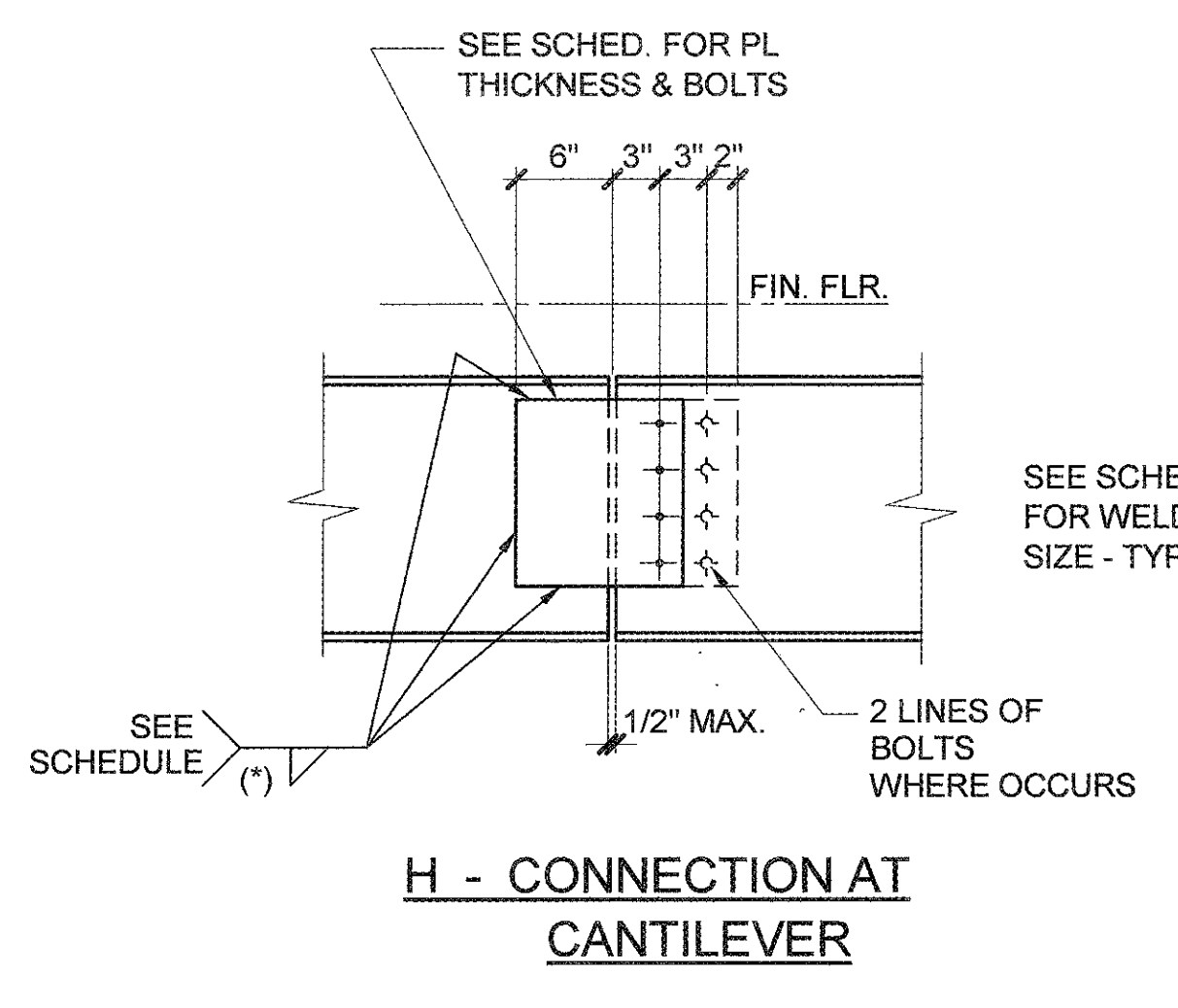
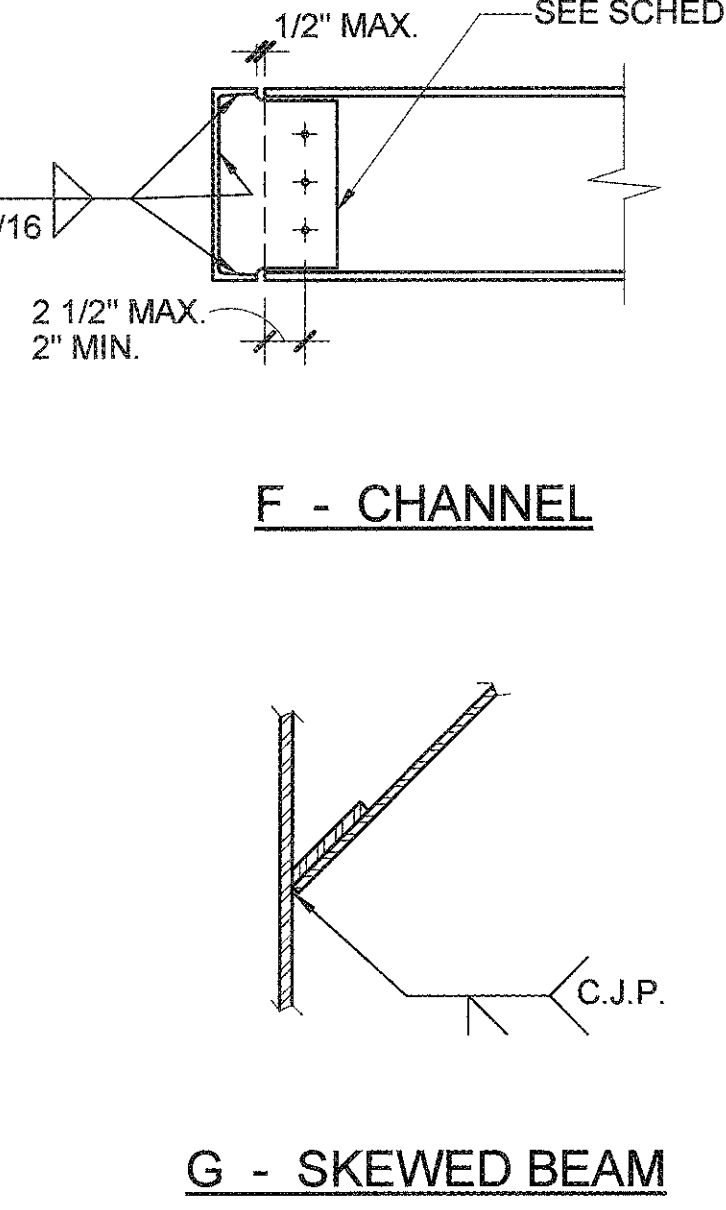
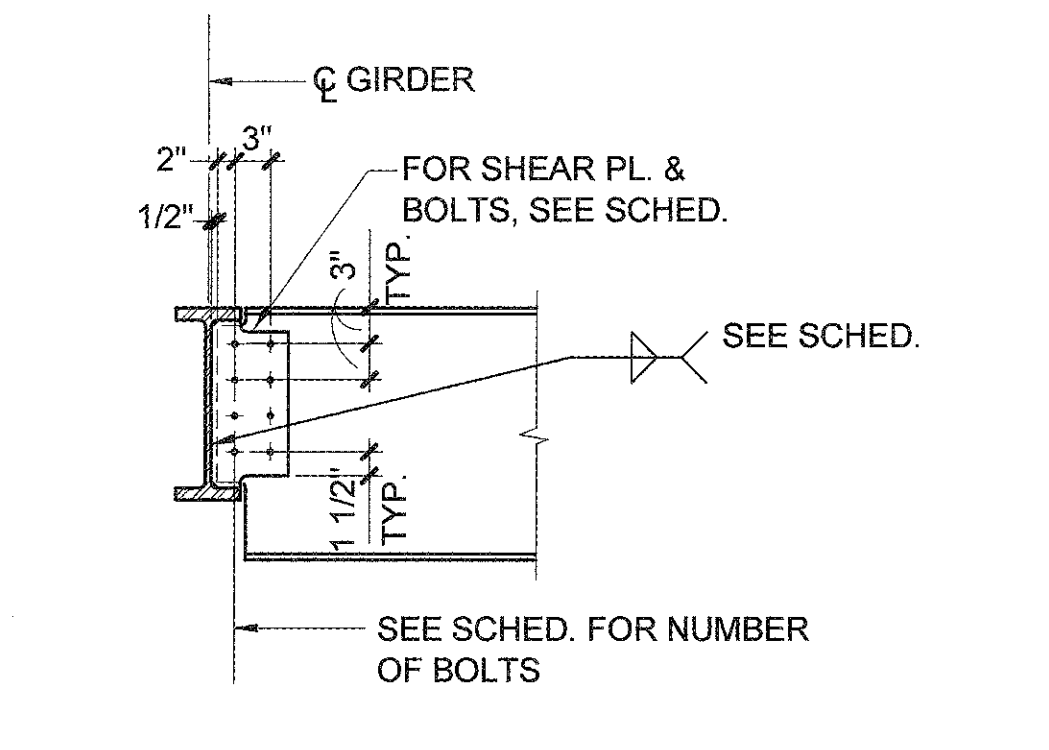
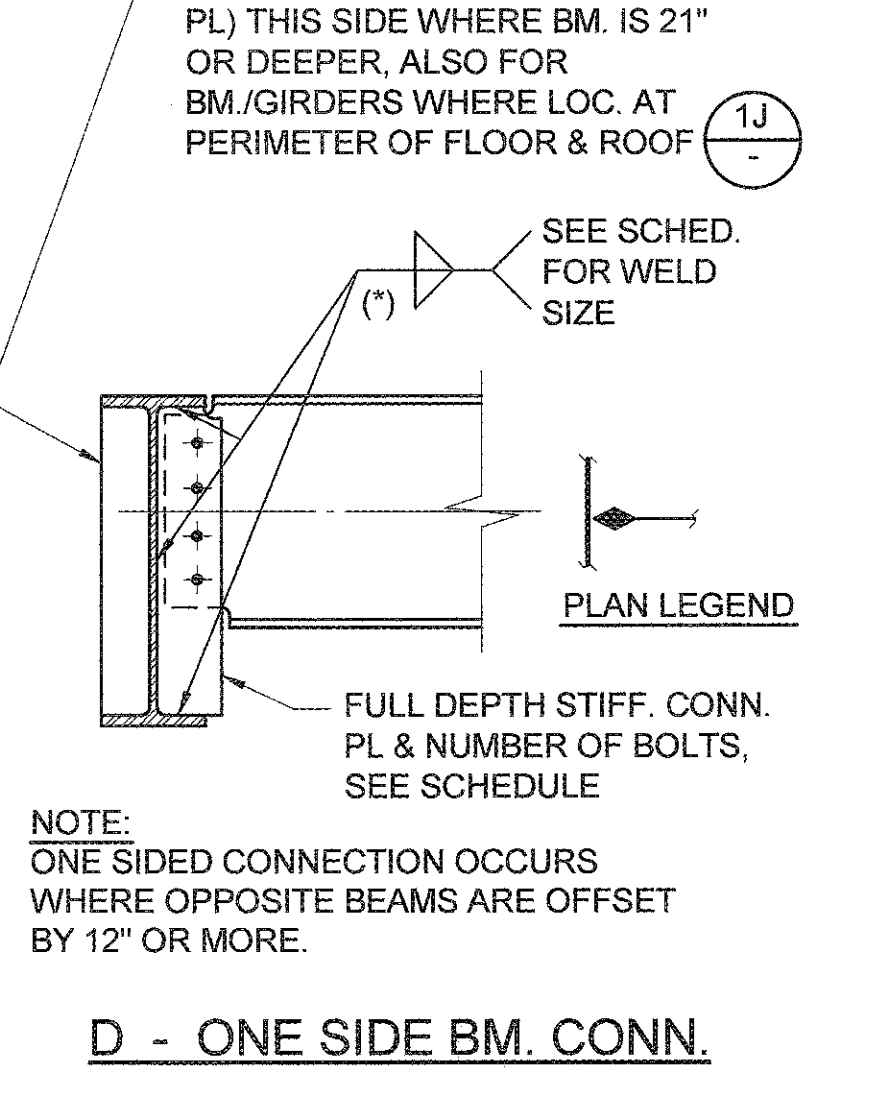
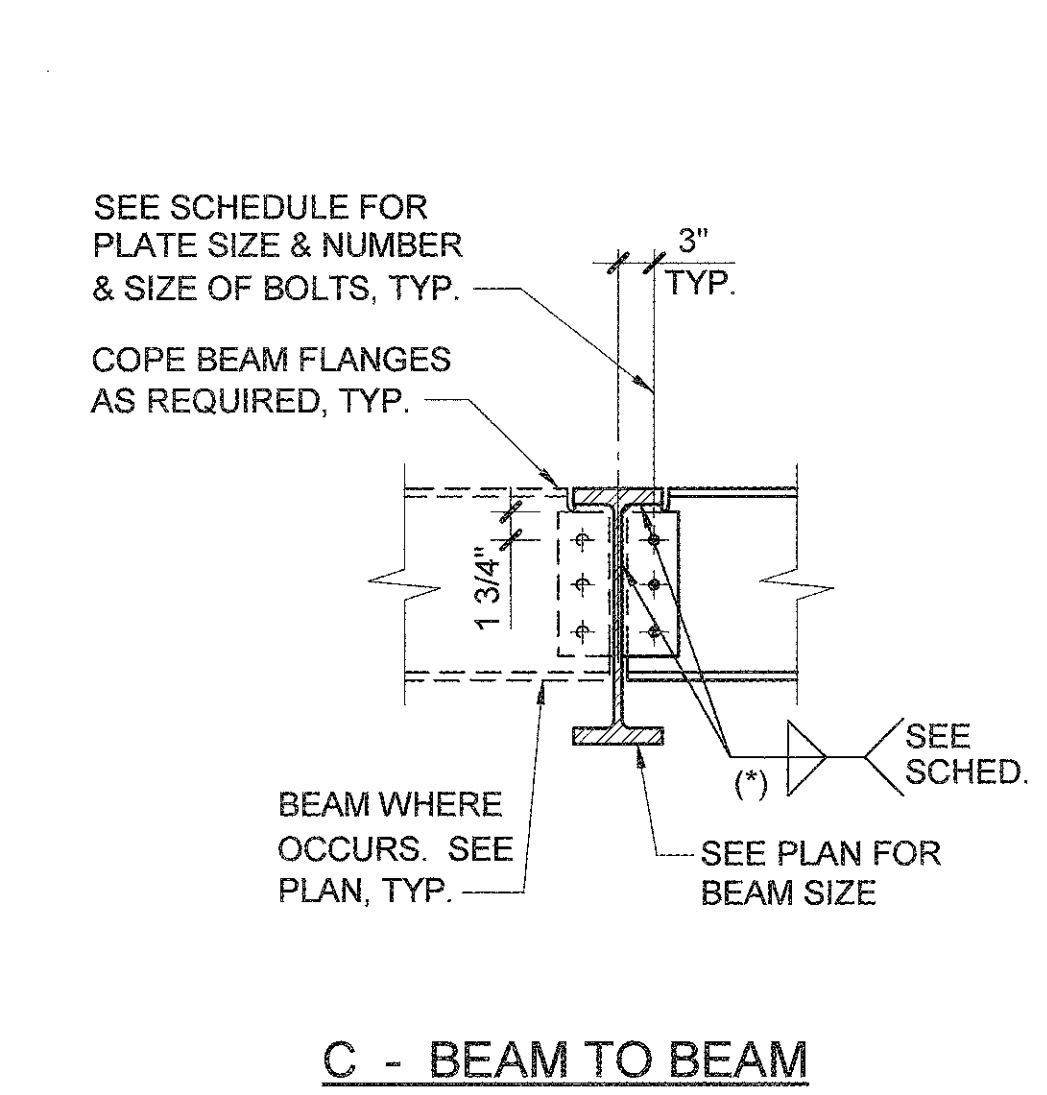
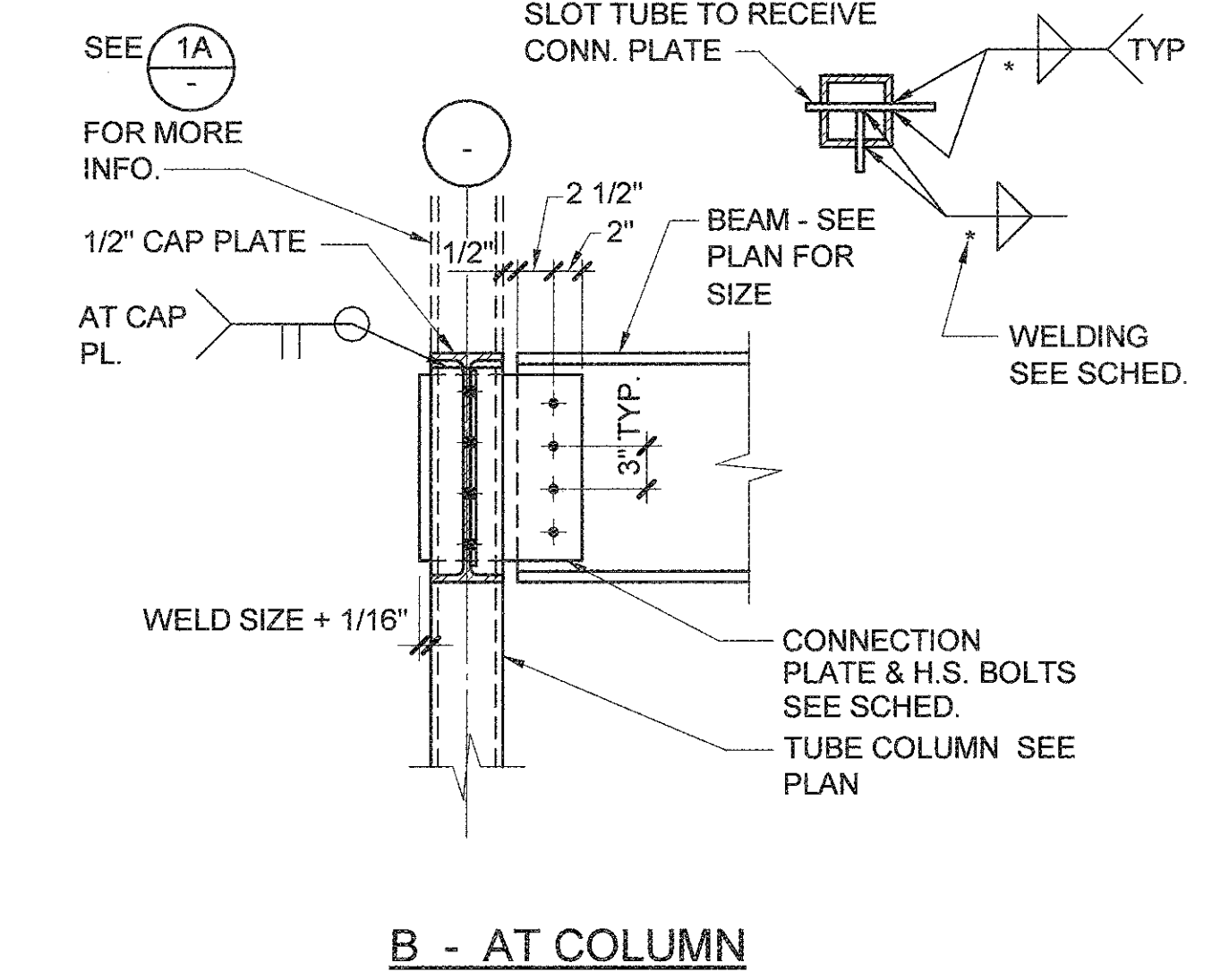
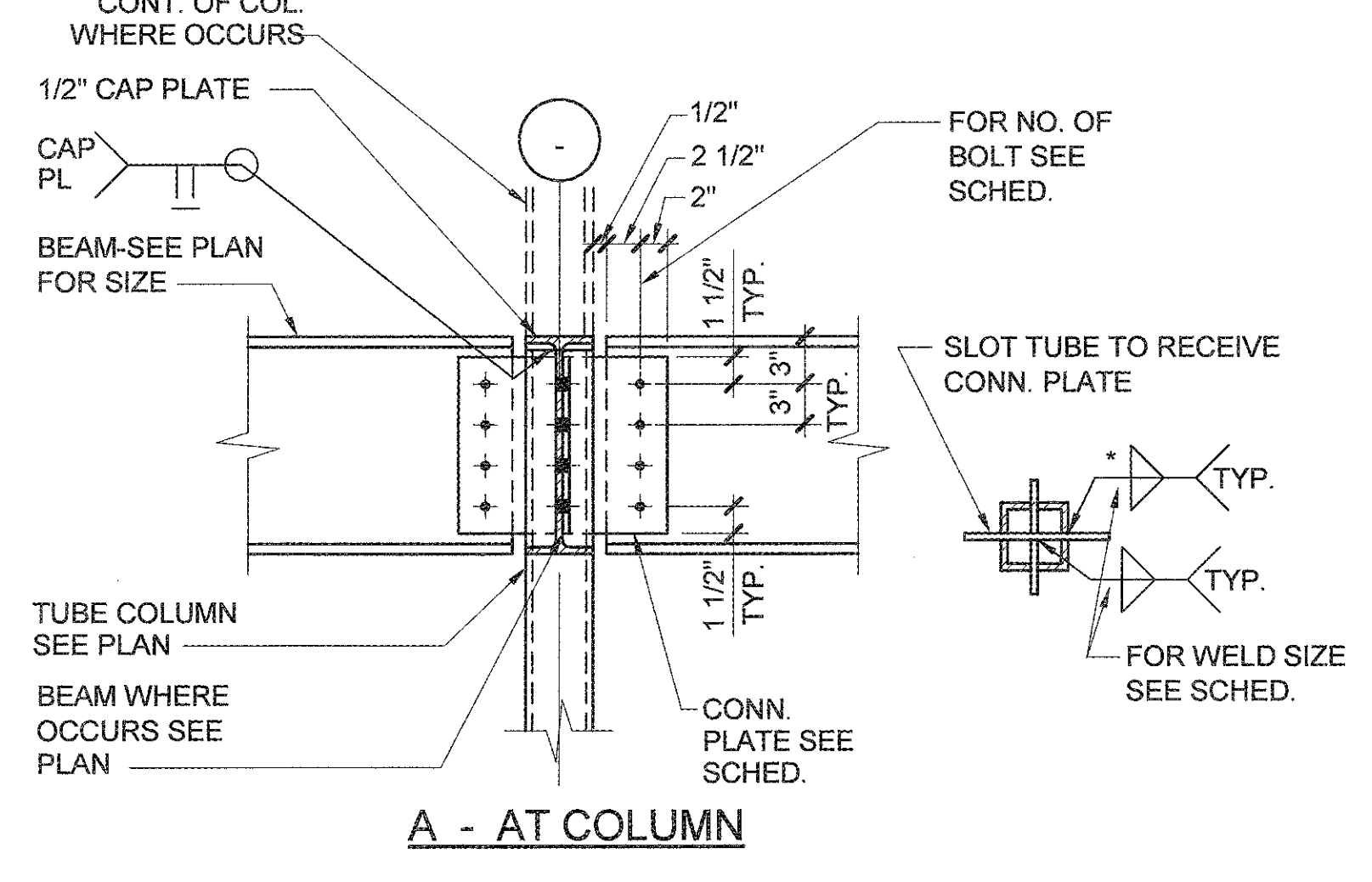

TYPICAL BEAM TO BEAM CONNECTION DETAILS AND SCHEDULE

NONE 1

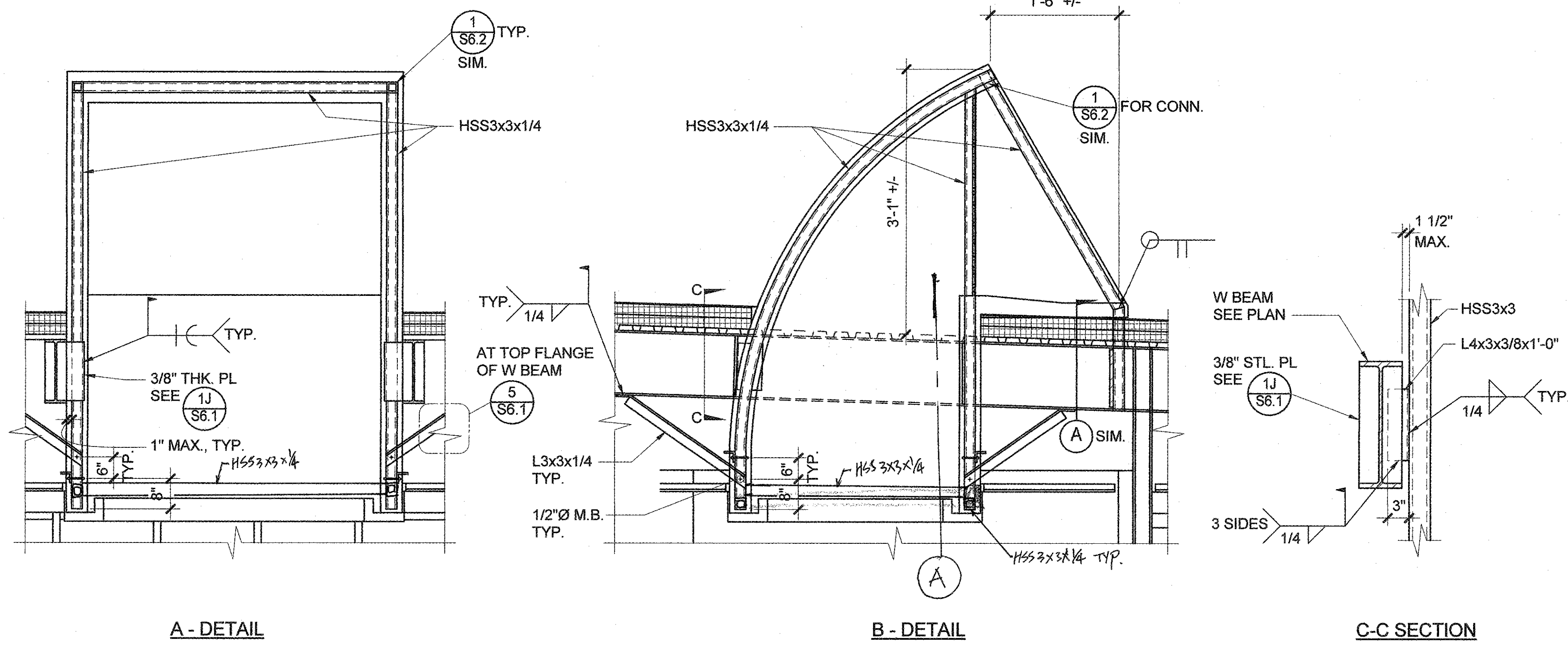

TYPICAL CLERESTORY SUPPORT DETAILS

NONE 9

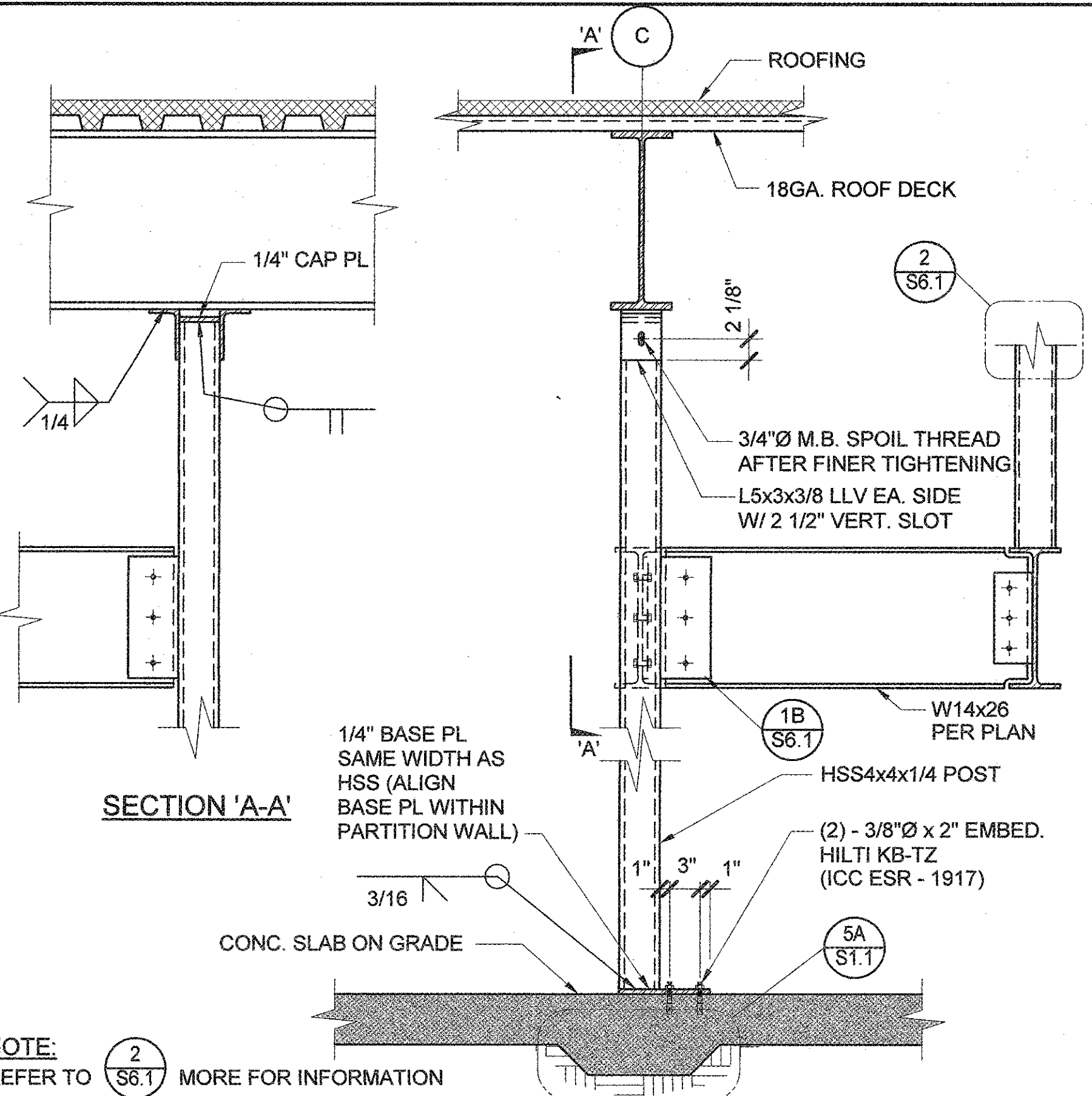

OPENING FRAMING

NONE 11

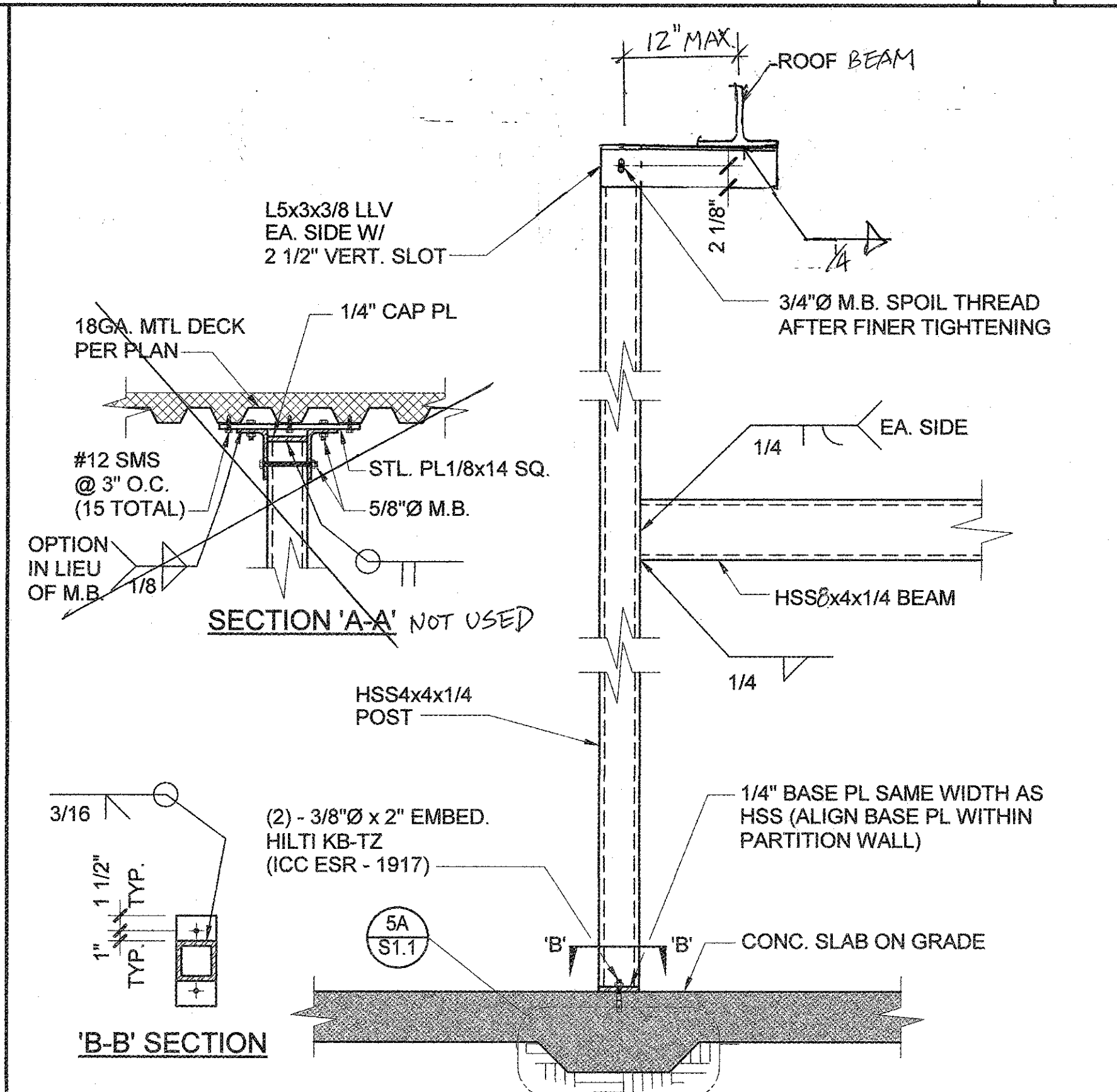

DOOR FRAMING

NONE 8

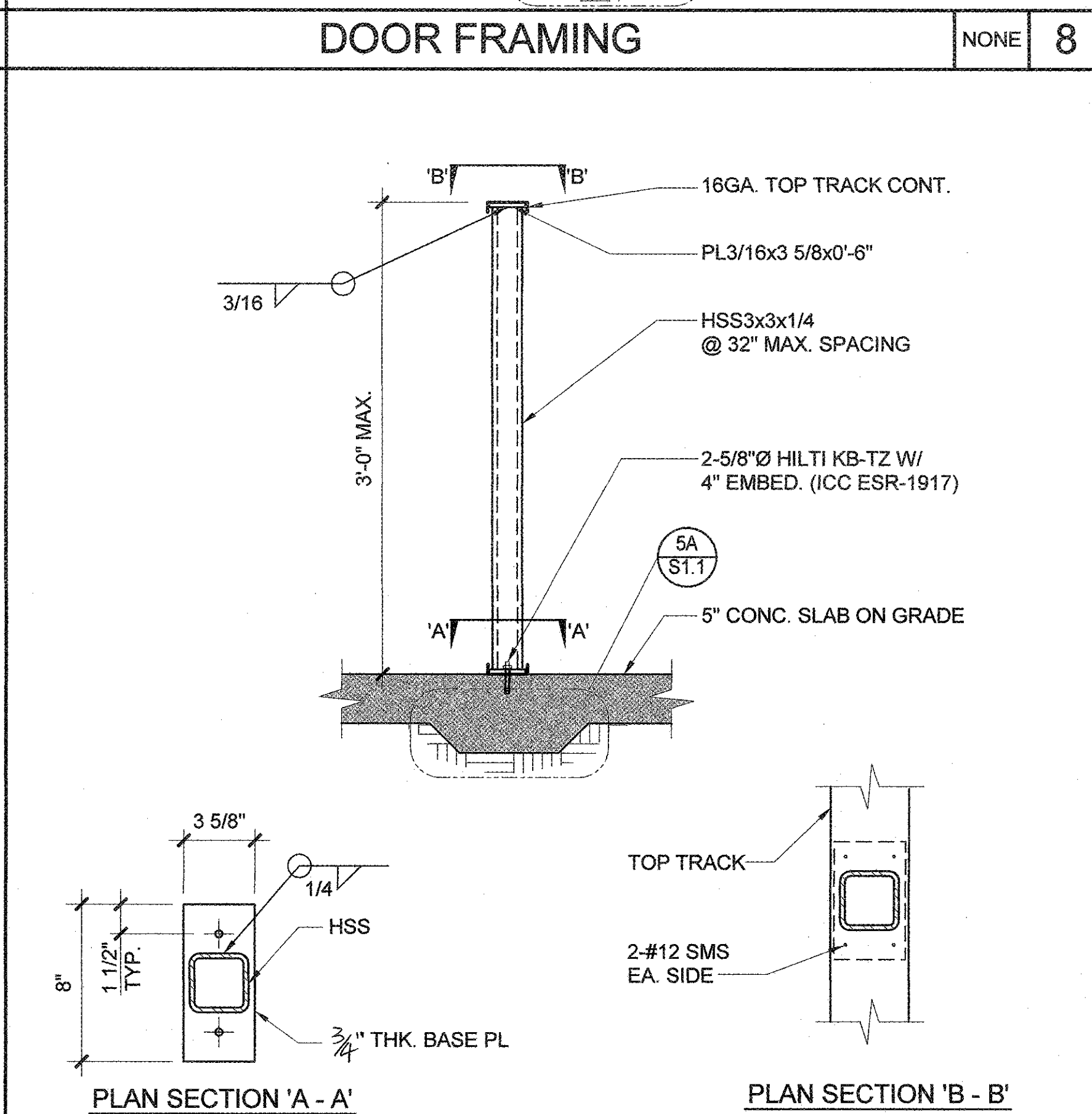

LOW WALL SUPPORT

NONE 7

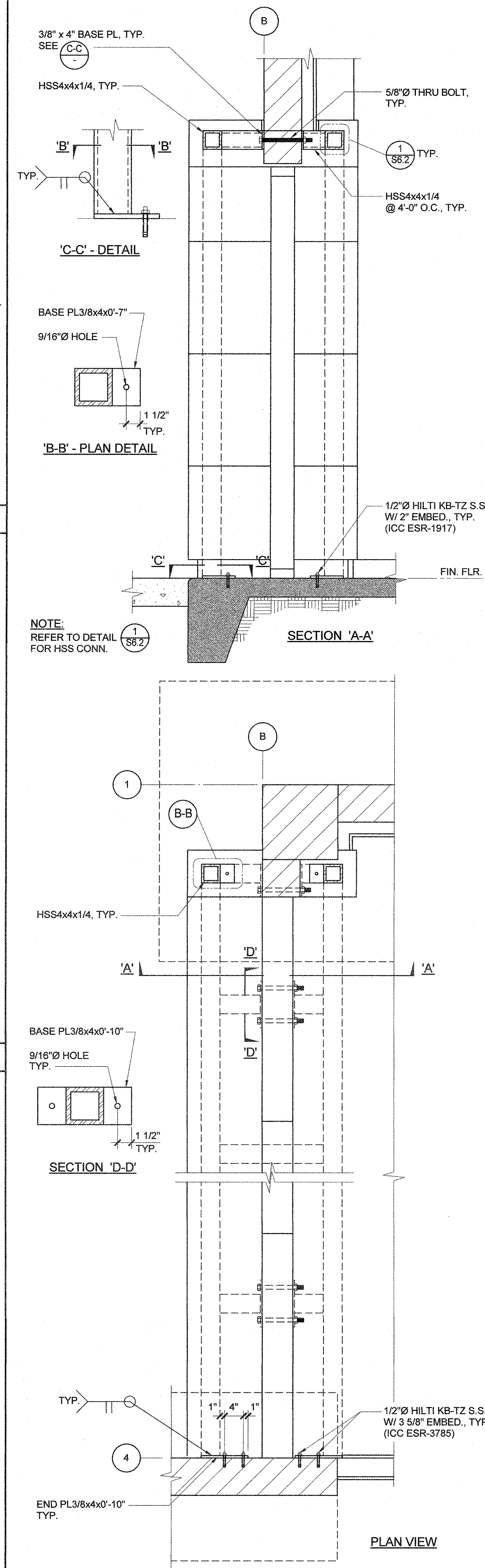

FRONT ENTRY FRAMING DETAIL

NONE 4

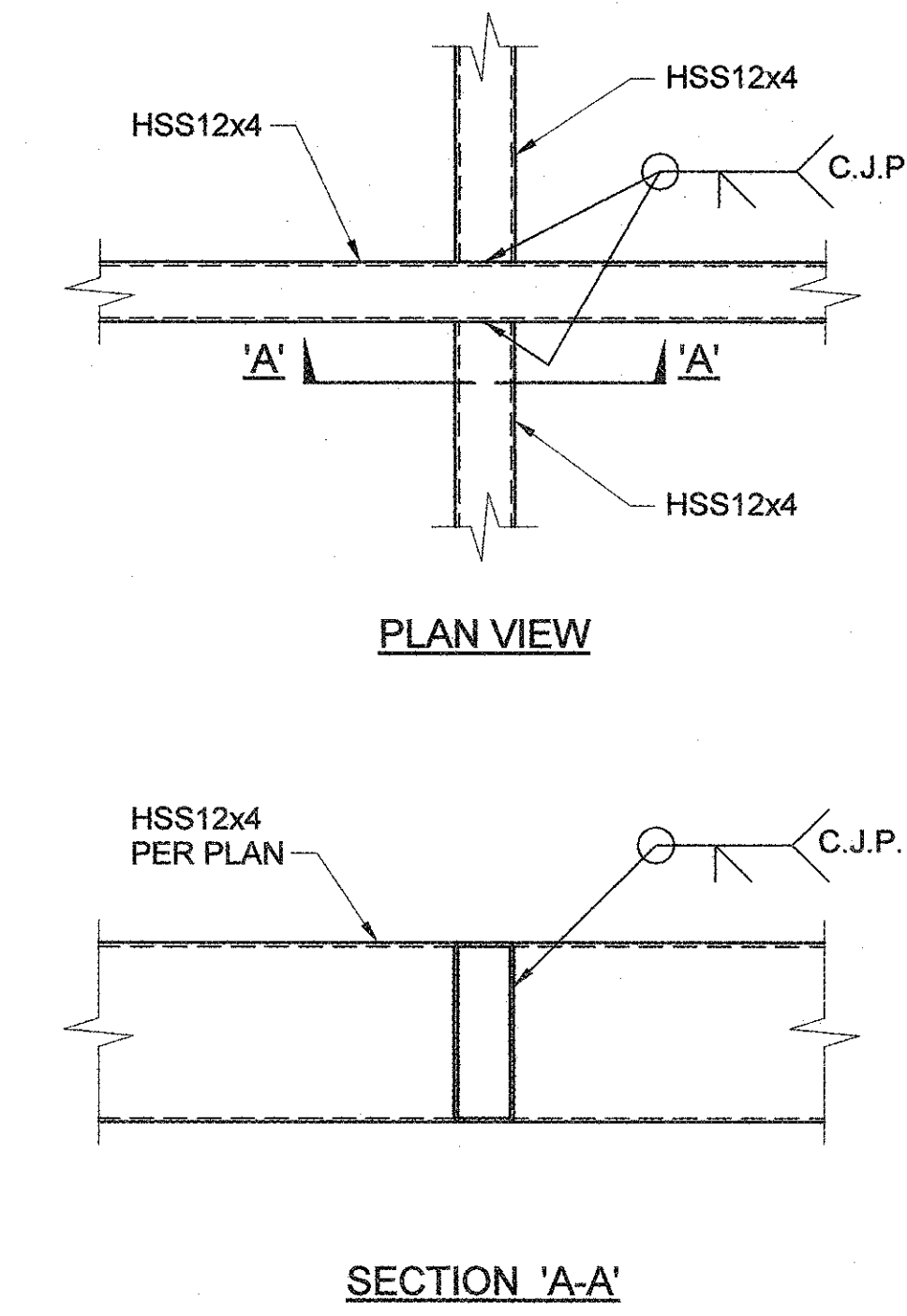

HSS MOMENT CONNECTION

NONE 3

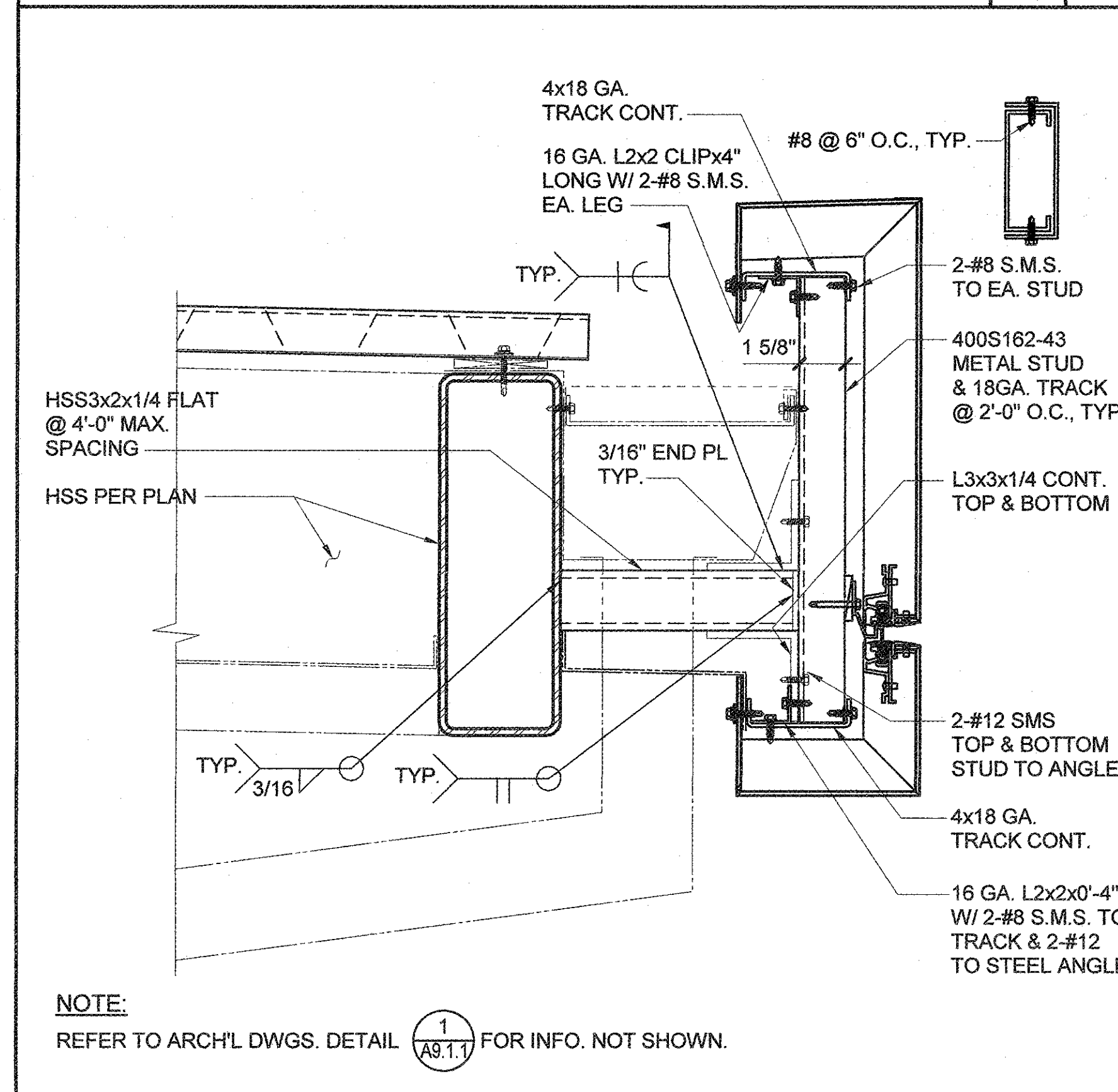

CANOPY FACIA SUPPORT DETAIL

NONE 2

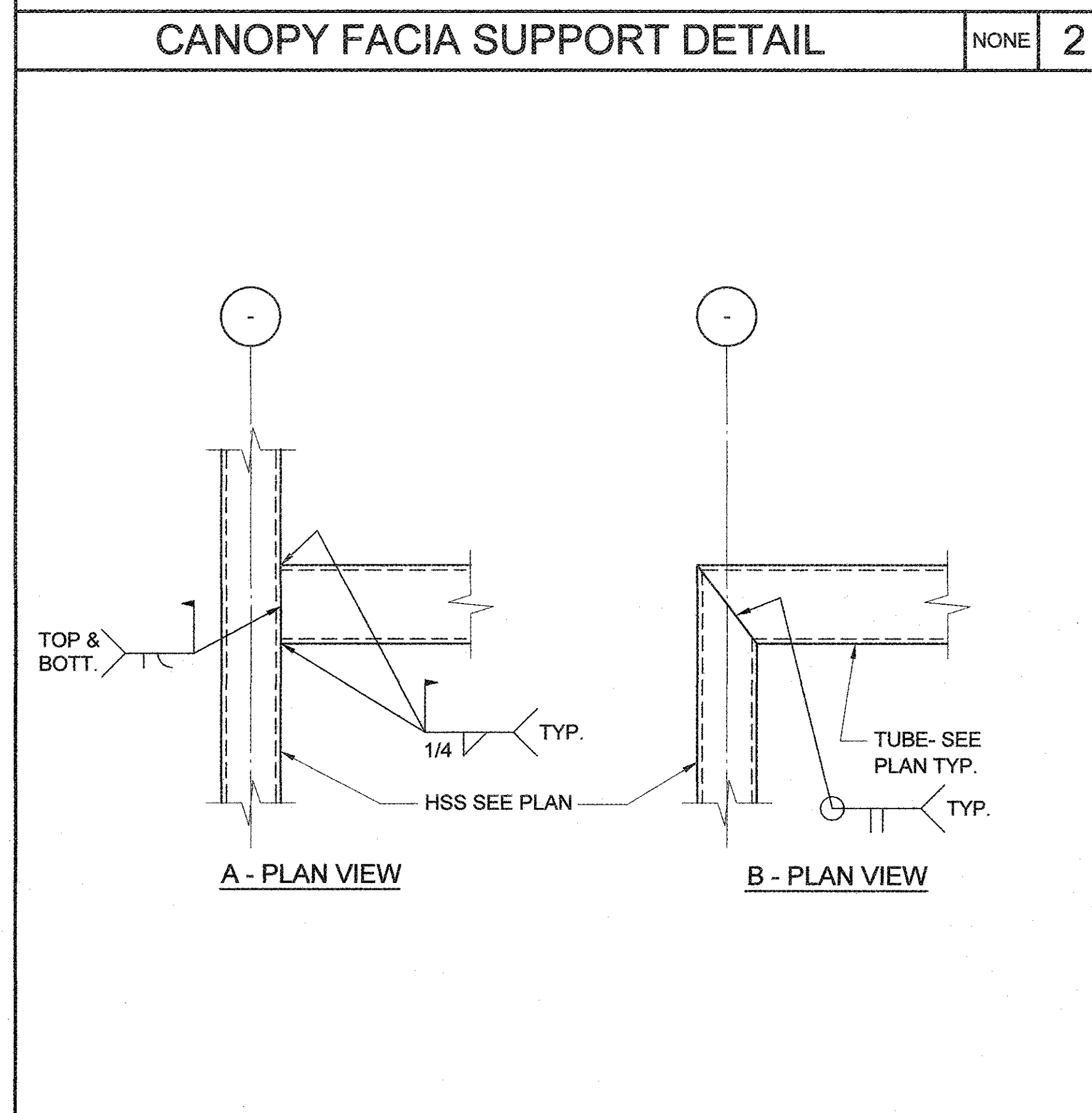

HSS TO HSS CONN.

NONE 1

NOT USED

10

VENTILATION FAN UNIT SCHEDULE																															
SYMBOL	MANUFACTURER AND MODEL NUMBER	LOCATION AND DRAWING REFERENCE	SERVICE	TYPE	SUPPLY FAN						HEATING COIL						ELECTRICAL DATA						MOUNTING DETAIL	OPERATING WEIGHT (LB)	REMARKS						
					AIRFLOW (CFM)	ESP (IN WG)	RPM	BHP	DRIVE	MOTOR HP	MINIMUM OSA (CFM)	CAPACITY (MBH)	FACE VELOCITY (FFM)	ENT (°F)	LVG (°F)	PD (IN WG)	ENT (°F)	LVG (°F)	PD (FT WG)	TYPE	QTY	W x L x D (IN)				MCA	VOLTS	PHASE	HERTZ		
VF 1	COOK 100KSP-B	ROOF	-	ROOF MOUNTED	1,575	0.5	795	0.360	BELT	1/2	1,575	-	-	-	-	-	-	-	-	-	-	-	-	-	-	-	-	-	M5.0.1 5	400	PRE-FABRICATED ROOF CURB, JCI VFD WITH BACNET INTERFACE.

EXHAUST FAN SCHEDULE																					
SYMBOL	MANUFACTURER AND MODEL NUMBER	LOCATION AND DRAWING REFERENCE	SERVICE	TYPE	CAPACITY (CFM)	SP (IN.)	RPM	BHP	DRIVE				ELECTRICAL CHARACTERISTICS				MOUNTING DETAIL	OPERATING WEIGHT (LB)	REMARKS		
									TYPE	VFD	HP	VOLTS	PHASE	HERTZ	TYPE	VOLTS				PHASE	HERTZ
EF 1	COOK ACRU-B 150R4B	ROOF	EXHAUST	UPBLAST ROOF MOUNTED	1,575	0.5	1006	0.260	BELT	Y	1/3	208	1	60	M5.0.1 5	200	BACK DRAFT DAMPER, PRE-FABRICATED ROOF CURB: COOK RCG-40, WEIGHT IS INCLUDED IN THE OPER. WEIGHT OF FAN, JCI VFD WITH BACNET INTERFACE, COOK LORENZED COATING.				

AIR COOLED VARIABLE REFRIGERANT FLOW CONDENSING UNIT																											
SYMBOL	MANUFACTURER AND MODEL NUMBER	LOCATION AND DRAWING REFERENCE	SERVICE	TYPE HEAT RECOVERY	BC CONTROLLER	COOLING			HEATING			COMPRESSOR				ELECTRICAL DATA				MOUNTING DETAIL	OPERATING WEIGHT (LB)	REMARKS					
						CAPACITY (MBH)	EFF.	AMBIENT TEMP (°F)	CAPACITY (MBH)	EFF.	AMBIENT TEMP (°F)	REFRIG-ERANT TYPE	QTY.	TYPE	RLA	LRA	MCA	MOCP	VOLTS				PHASE	HERTZ			
CU 1	LG ARUB192BTE4	-	1ST FLOOR	HEAT RECOVERY FLOOR MTD	-	192.0	EER	90	216.0	COP	37	R410A	2	SCROLL	17.0 27.4	-	25.3 40.3	40 60	208	3	60	M5.0.1 4	1,200	1. INDIVIDUAL POWER CONNECTION FOR EA MCA & MOCP LISTED. 2. CONTRACTOR TO FIELD INSTALL TWINNING KIT			

DIRECT EXPANSION FAN COIL UNIT SCHEDULE																											
SYMBOL	MANUFACTURER AND MODEL NUMBER	LOCATION AND DRAWING REFERENCE	SERVICE	TYPE	SUPPLY FAN				MINIMUM OSA (CFM)	COOLING		HEATING		REFRIGERANT		FILTERS				ELECTRICAL DATA				MOUNTING DETAIL	OPERATING WEIGHT (LB)	REMARKS	
					AIRFLOW (CFM)	ESP (IN WG)	DRIVE	MOTOR OUTPUT (W)		TOTAL (MBH)	SENSIBLE (MBH)	AIR PD (IN WG)	TOTAL (MBH)	TYPE	SUCTON LINE SIZE (IN)	LIQUID LINE SIZE (IN)	TYPE	QTY	W x L x D (IN)	MCA	MOCP	VOLTS	PHASE				HERTZ
FC 1	LG ARNU183TQC4	-	-	SUSPENDED CASSETTE	395	-	DIRECT	-	45	19.1	14.0	-	21.5	R410A	1/2	1/4	MERV 13	-	-	0.25	15	208	1	60	M5.0.1 3	100	PROVIDE VENTILATION KIT
FC 2	LG ARNU093BG4A	-	-	SUSPENDED DUCTED	450	0.48	DIRECT	-	30	9.6	7.0	-	11.3	R410A	5/8	3/8	MERV 13	-	-	3.3	15	208	1	60	M5.0.1 1	150	-
FC 3	LG ARNU093TRC4	-	-	SUSPENDED CASSETTE	280	-	DIRECT	-	30	9.6	7.0	-	10.9	R410A	1/2	1/4	MERV 13	-	-	0.25	15	208	1	60	M5.0.1 3	100	PROVIDE VENTILATION KIT
FC 4	LG ARNU073BG4A	-	-	SUSPENDED DUCTED	260	0.48	DIRECT	-	45	6.9	5.3	-	8.8	R410A	5/8	3/8	MERV 13	-	-	3.3	15	208	1	60	M5.0.1 1	150	-
FC 5	LG ARNU093BG4A	-	-	SUSPENDED DUCTED	450	0.48	DIRECT	-	60	9.6	7.0	-	11.3	R410A	5/8	3/8	MERV 13	-	-	3.3	15	208	1	60	M5.0.1 1	150	-
FC 6	LG ARNU483BRZ4	-	-	SUSPENDED DUCTED	840	0.39	DIRECT	-	840	44.3	32.2	-	32.2	R410A	5/8	3/8	MERV 13	-	-	1.5	15	208	1	60	M5.0.1 1	200	-
FC 7	LG ARNU283BG4A	-	-	SUSPENDED DUCTED	930	0.56	DIRECT	-	350	28.1	20.7	-	32.5	R410A	5/8	3/8	MERV 13	-	-	3.3	15	208	1	60	M5.0.1 1	150	-
FC 8	LG ARNU123BG4A	-	-	SUSPENDED DUCTED	400	0.48	DIRECT	-	75	11.6	8.8	-	14.1	R410A	5/8	3/8	MERV 13	-	-	3.3	15	208	1	60	M5.0.1 1	150	-
FC 9	LG ARNU073BG4A	-	-	SUSPENDED DUCTED	240	0.48	DIRECT	-	30	6.8	5.3	-	8.8	R410A	5/8	3/8	MERV 13	-	-	3.3	15	208	1	60	M5.0.1 1	150	-
FC 10	LG ARNU243BG4A	-	-	SUSPENDED DUCTED	900	0.58	DIRECT	-	70	21.3	17.7	-	28.2	R410A	5/8	3/8	MERV 13	-	-	3.3	15	208	1	60	M5.0.1 1	150	-
FC 11	LG ARNU123SBL4	-	-	WALL MOUNT	370	-	DIRECT	-	0	12.3	8.8	-	-	R410A	1/2	1/4	MERV 13	-	-	0.2	15	208	1	60	M5.0.1 9	100	-
FC 12	LG ARNU053SBL4	-	-	WALL MOUNT	230	-	DIRECT	-	0	5.5	3.9	-	-	R410A	1/2	1/4	MERV 13	-	-	0.2	15	208	1	60	M5.0.1 9	100	-

NOTE: PROVIDE CONDENSATE RETURN PUMP AS NECESSARY IF REQUIRED DURING SHOP DRAWING PREPARATION.

HEAT RECOVERY UNIT SCHEDULE														
SYMBOL	MANUFACTURER AND MODEL NUMBER	LOCATION AND DRAWING REFERENCE	SERVICE	ELECTRICAL DATA						MOUNTING DETAIL	OPERATING WEIGHT (LB)	REMARKS		
				MCA	MOCP	VOLTS	PHASE	HERTZ						
HRU 1	HRU 2	HRU 3	LG PRHR042A	-	-	VRF SYSTEM	0.2	15	208	1	60	M5.0.1 1	80	-

LITTLE
DIVERSIFIED ARCHITECTURAL CONSULTING

1300 Dove Street, Suite 100
Newport Beach, CA 92660
T: 949.698.1400 F: 949.698.1433
www.littleonline.com

This drawing and the design thereon are the property of Little Diversified Architectural Consulting. The reproduction, copying or other use of this drawing without their written consent is prohibited and any infringement will be subject to legal action.

© Little 2015

COMPTON CCD

CAMPUS PUBLIC SAFETY BUILDING

**1111 EAST ARTESIA BOULEVARD,
COMPTON CALIFORNIA 90221**

IDENTIFICATION STAMP
DIV. OF THE STATE ARCHITECT
OFFICE OF REGULATION SERVICES

FILE NO: 19-C1
AR: 03-117673

AC: / PLS: / SS: /
DATE: DEC. 17, 2017

16516 dHA + CALPEC

150 S. ARROYO PARKWAY
SUITE NO. 100
PASADENA, CA 91105
TEL: (626) 446-8880
FAX: (626) 446-8081

PRINCIPAL IN CHARGE
KEVIN CHEN

PROJECT MANAGER

DRAWN BY
dHA+CALPEC

NO REASON DATE

REGISTERED PROFESSIONAL ENGINEER
M-31154
Exp. 12/31/17
STATE OF CALIFORNIA

MECHANICAL SCHEDULES

913-4675-01

11/21/16 M0.0.2

Table with 4 columns: Energy Component, Standard Design Site (DHS), Proposed Design Site (DHS), Margin (DHS), Standard Design Site (DHS), Proposed Design Site (DHS), Margin (DHS). Rows include Space Heating, Space Cooling, Indoor Fans, Heat Rejection, Pumps & Misc., Domestic Hot Water, Indoor Lighting, Recirculation, Process, Other Usg, and TOTAL.

Table with 4 columns: Project Name, Project Address, Compliance Scope, Input File Name. Includes project details for Compton College Campus Public Safety Building.

Table with 4 columns: Project Name, Project Address, Compliance Scope, Input File Name. Includes project details for Compton College Campus Public Safety Building.

Table with 4 columns: Project Name, Project Address, Compliance Scope, Input File Name. Includes project details for Compton College Campus Public Safety Building.

Table with 4 columns: Project Name, Project Address, Compliance Scope, Input File Name. Includes project details for Compton College Campus Public Safety Building.

Table with 4 columns: Project Name, Project Address, Compliance Scope, Input File Name. Includes project details for Compton College Campus Public Safety Building.

Table with 4 columns: Project Name, Project Address, Compliance Scope, Input File Name. Includes project details for Compton College Campus Public Safety Building.

Table with 4 columns: Project Name, Project Address, Compliance Scope, Input File Name. Includes project details for Compton College Campus Public Safety Building.

Table with 4 columns: Project Name, Project Address, Compliance Scope, Input File Name. Includes project details for Compton College Campus Public Safety Building.

Table with 4 columns: Project Name, Project Address, Compliance Scope, Input File Name. Includes project details for Compton College Campus Public Safety Building.

Table with 4 columns: Project Name, Project Address, Compliance Scope, Input File Name. Includes project details for Compton College Campus Public Safety Building.

Table with 4 columns: Project Name, Project Address, Compliance Scope, Input File Name. Includes project details for Compton College Campus Public Safety Building.

Table with 4 columns: Project Name, Project Address, Compliance Scope, Input File Name. Includes project details for Compton College Campus Public Safety Building.

Table with 4 columns: Project Name, Project Address, Compliance Scope, Input File Name. Includes project details for Compton College Campus Public Safety Building.

Table with 4 columns: Project Name, Project Address, Compliance Scope, Input File Name. Includes project details for Compton College Campus Public Safety Building.

Table with 4 columns: Project Name, Project Address, Compliance Scope, Input File Name. Includes project details for Compton College Campus Public Safety Building.

Table with 4 columns: Project Name, Project Address, Compliance Scope, Input File Name. Includes project details for Compton College Campus Public Safety Building.

Table with 4 columns: Project Name, Project Address, Compliance Scope, Input File Name. Includes project details for Compton College Campus Public Safety Building.

Table with 4 columns: Project Name, Project Address, Compliance Scope, Input File Name. Includes project details for Compton College Campus Public Safety Building.

Table with 4 columns: Project Name, Project Address, Compliance Scope, Input File Name. Includes project details for Compton College Campus Public Safety Building.

Table with 4 columns: Project Name, Project Address, Compliance Scope, Input File Name. Includes project details for Compton College Campus Public Safety Building.

Table with 4 columns: Project Name, Project Address, Compliance Scope, Input File Name. Includes project details for Compton College Campus Public Safety Building.

Table with 4 columns: Project Name, Project Address, Compliance Scope, Input File Name. Includes project details for Compton College Campus Public Safety Building.

Table with 4 columns: Project Name, Project Address, Compliance Scope, Input File Name. Includes project details for Compton College Campus Public Safety Building.

Table with 4 columns: Project Name, Project Address, Compliance Scope, Input File Name. Includes project details for Compton College Campus Public Safety Building.

Table with 4 columns: Project Name, Project Address, Compliance Scope, Input File Name. Includes project details for Compton College Campus Public Safety Building.

Table with 4 columns: Project Name, Project Address, Compliance Scope, Input File Name. Includes project details for Compton College Campus Public Safety Building.

Table with 4 columns: Project Name, Project Address, Compliance Scope, Input File Name. Includes project details for Compton College Campus Public Safety Building.

REFERENCE NOTES

- ① 18x16 EA DUCT UP THRU ROOF TO EF-1
- ② 18x16 SA DUCT UP THRU ROOF TO VF-1
- ③ 6x6 SA GRILLE
- ④ 6x6 RA GRILLE

**COMPTON
CCD**

**COMPTON COLLEGE CAMPUS PUBLIC
SAFETY BUILDING**
1111 EAST ARTESIA BOULEVARD,
COMPTON CALIFORNIA 90221

IDENTIFICATION STAMP
DIV. OF THE STATE ARCHITECT
OFFICE OF REGULATION SERVICES
FILE NO: 19-C1
APR. 03-117673
AC / FLS / SS
DATE DEC. 17, 2017

16516
dHA + CALPEC
155 S. ARROYO PARKWAY
SUITE NO. 100
PASADENA, CA 91105
TEL: (626) 445-8330
FAX: (626) 445-8081

PRINCIPAL IN CHARGE
KEVIN CHEN
PROJECT MANAGER
Checker
DRAWN BY
dHA+CALPEC

NO REASON DATE



MECHANICAL-FLOOR PLAN

100% CD SET
913-4675-01

11/21/2017 M2.1.1

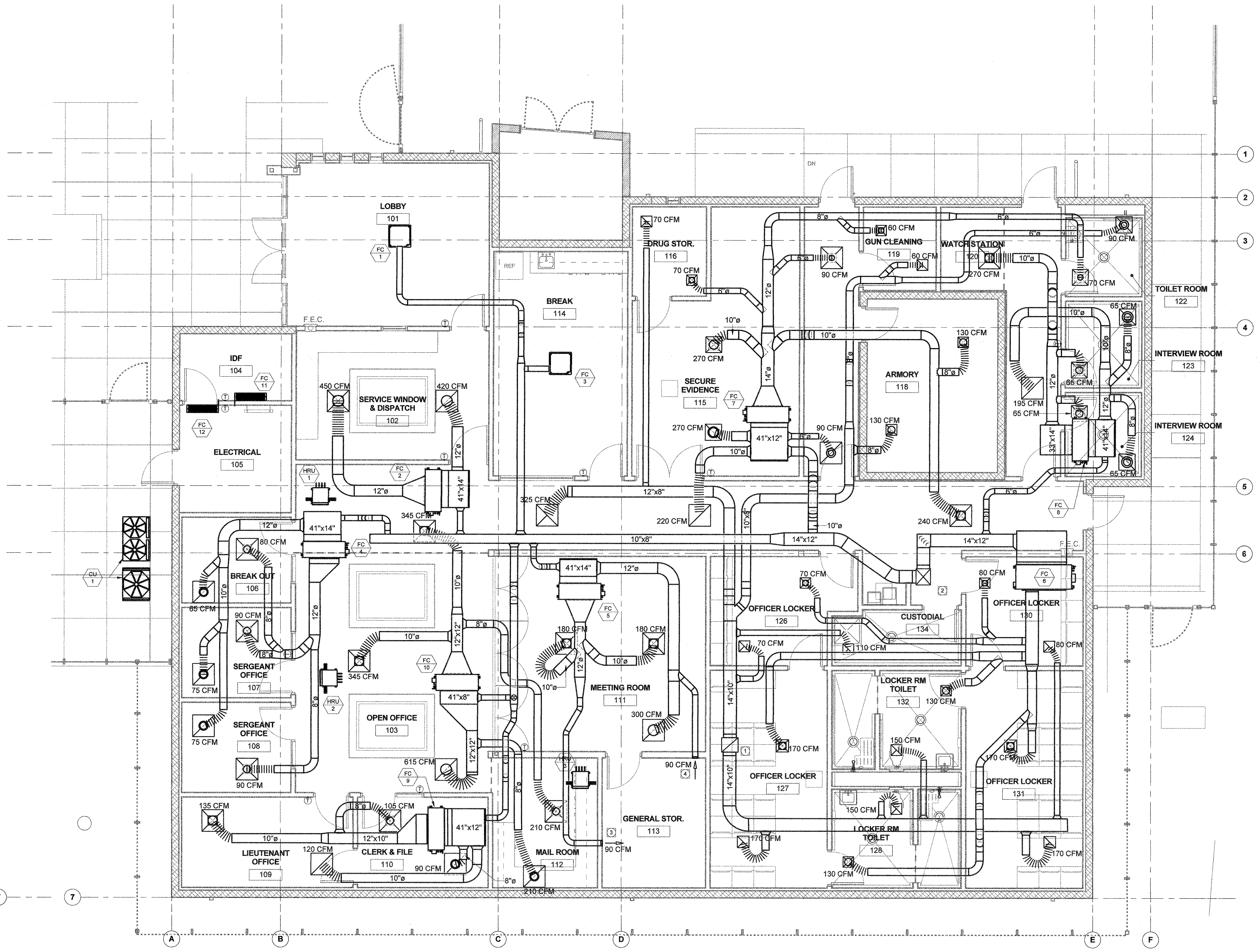

① MECHANICAL FLOOR PLAN
1/4" = 1'-0"

**COMPTON
CCD**

**COMPTON COLLEGE CAMPUS PUBLIC
SAFETY BUILDING**

1111 EAST ARTESIA BOULEVARD,
COMPTON CALIFORNIA 90221

IDENTIFICATION STAMP
DIV. OF THE STATE ARCHITECT
OFFICE OF REGULATION SERVICES

FILE NO: 19-C1
AP: 03-117673

AC: FLETT
DATE: DEC 12 2017

16516
dHA + CALPEC
155 S. ARROYO PARKWAY
SUITE NO. 100
PASADENA, CA 91105
TEL: (626) 445-8880
FAX: (626) 445-8081

PRINCIPAL IN CHARGE
KEVIN CHEN
PROJECT MANAGER
Checker
DRAWN BY
dHA+CALPEC

NO	REASON	DATE



MECHANICAL-ROOF PLAN

100% CD SET

913-4675-01

11/21/2017 M2.1.2

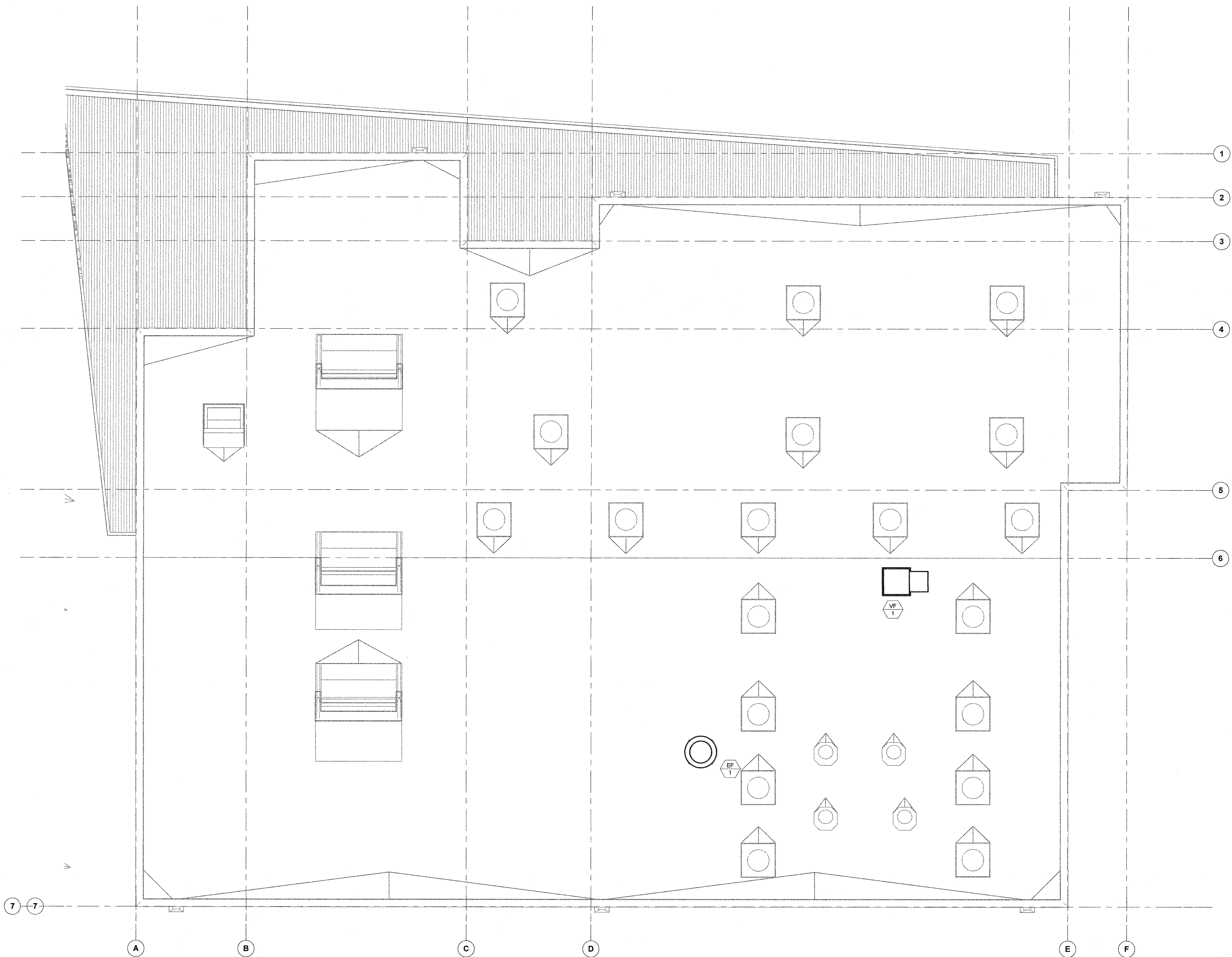

① MECHANICAL ROOF PLAN
1/4" = 1'-0"

REFERENCE NOTES

- ① 3/8" LIQUID , 5/8" HPV & 3/4" LPV REFRIGERANT PIPING
- ② 1/2" LIQUID , 3/4" HPV & 1-1/8" LPV REFRIGERANT PIPING
- ③ 5/8" LIQUID , 7/8" HPV & 1-1/8" LPV REFRIGERANT PIPING
- ④ 3/8" LIQUID , 1/2" HPV & 5/8" LPV REFRIGERANT PIPING
- ⑤ 1/2" LIQUID , 7/8" HPV & 1-1/8" LPV REFRIGERANT PIPING
- ⑥ 3/8" LIQUID , 3/4" HPV & 7/8" LPV REFRIGERANT PIPING
- ⑦ 3/8" LIQUID , 1/2" HPV & 5/8" LPV REFRIGERANT PIPING
- ⑧ 1/4" LIQUID & 1/2" VAPOR REFRIGERANT PIPING
- ⑨ 3/8" LIQUID & 5/8" VAPOR REFRIGERANT PIPING
- ⑩ Y-BRANCH UNIT FROM MANUFACTURER
- ⑪ 3/4" CD DOWN TO CUSTODIAL SINK.

**COMPTON
CCD**

**COMPTON COLLEGE CAMPUS PUBLIC
SAFETY BUILDING**
1111 EAST ARTESIA BOULEVARD,
COMPTON CALIFORNIA 90221

IDENTIFICATION STAMP
DIV. OF THE STATE ARCHITECT
OFFICE OF REGULATION SERVICES
FILE NO: 18-C1
AR: 03-117673
AC: FLS SS
DATE: DEC 12 2017

16516
dHA + CALPEC
150 S. ARROYO PARKWAY
SUITE NO. 100
PASADENA, CA 91105
TEL: (626) 445-8500
FAX: (626) 445-8081

PRINCIPAL IN CHARGE
KEVIN CHEN
PROJECT MANAGER
Checker
DRAWN BY
dHA+CALPEC

NO REASON DATE



MECHANICAL-PIPING PLAN

100% CD SET

913-4675-01

11/21/2017 M2.2.1

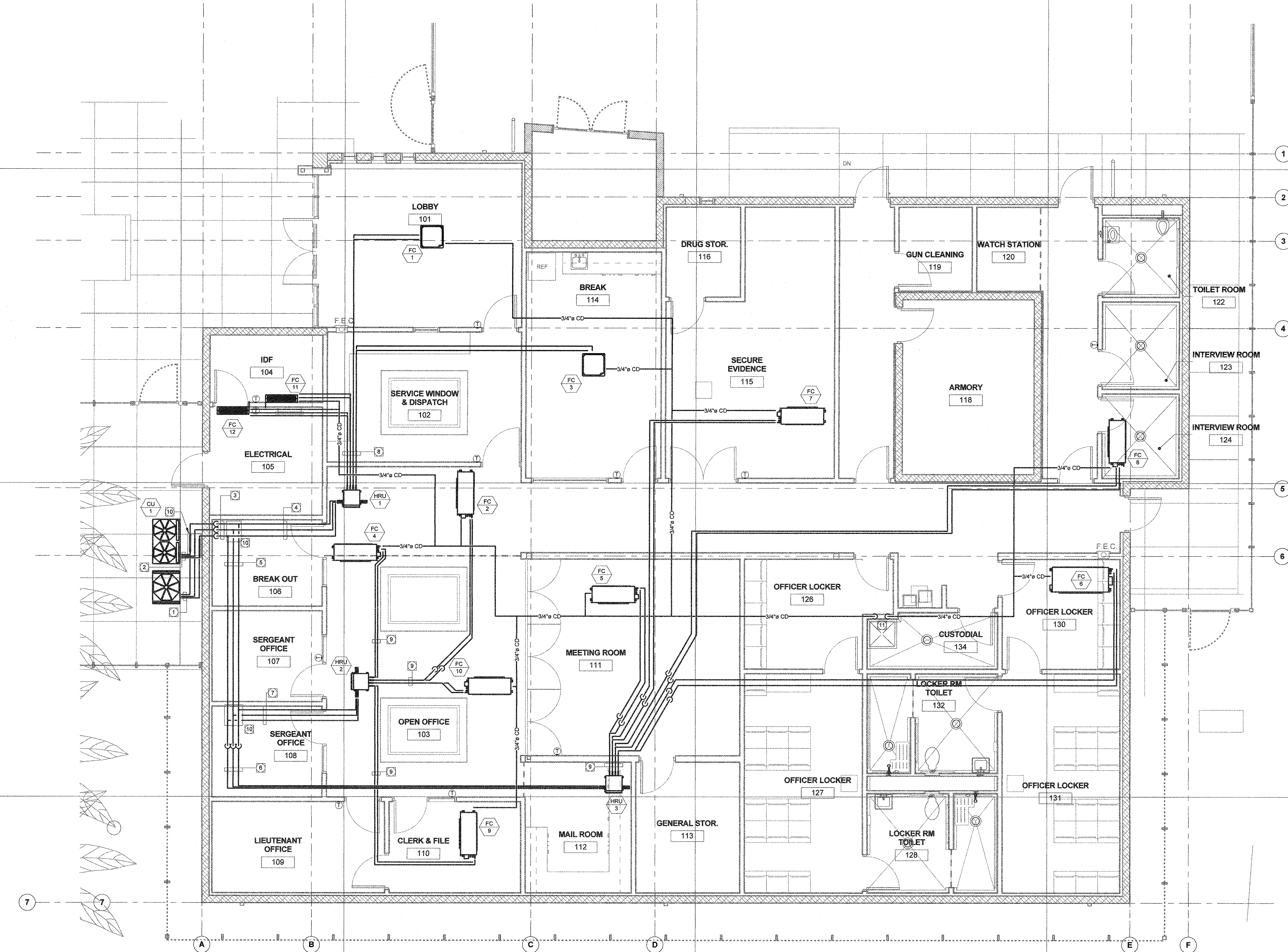

① MECHANICAL PIPING FLOOR PLAN
1/4" = 1'-0"

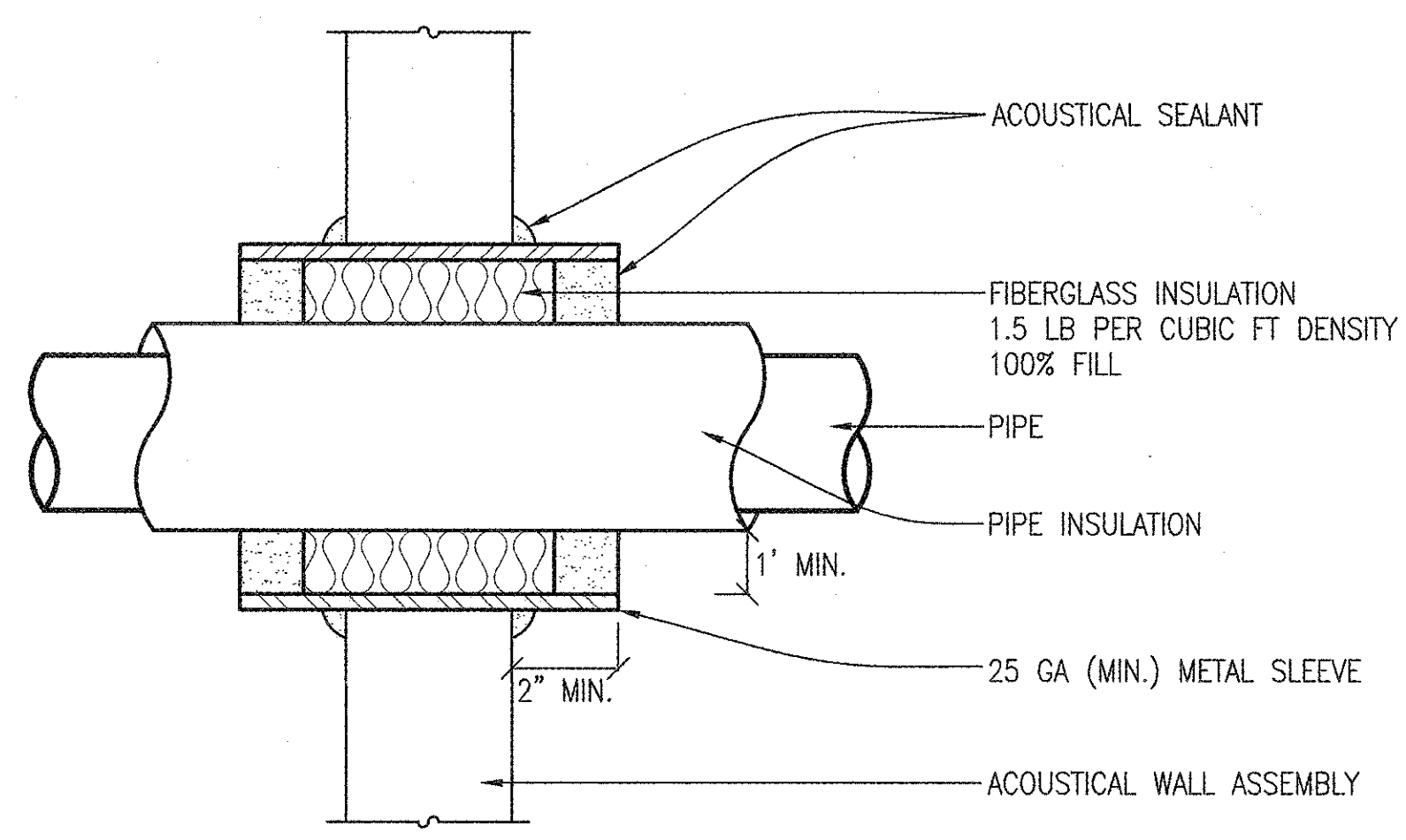

- NOTES:**
- SPACE BETWEEN PIPE AND SLEEVE SHALL BE FREE OF ANY FOREIGN MATERIALS.
 - PIPE SHALL NOT CONTACT STRUCTURE AT ANY TIME. WEDGES SHALL NOT BE USED TO MAINTAIN PIPE IN POSITION.
 - PIPE MUST BE CENTERED IN OPENING.

PIPE PENETRATION THROUGH NON-RATED WALL N.T.S. 10

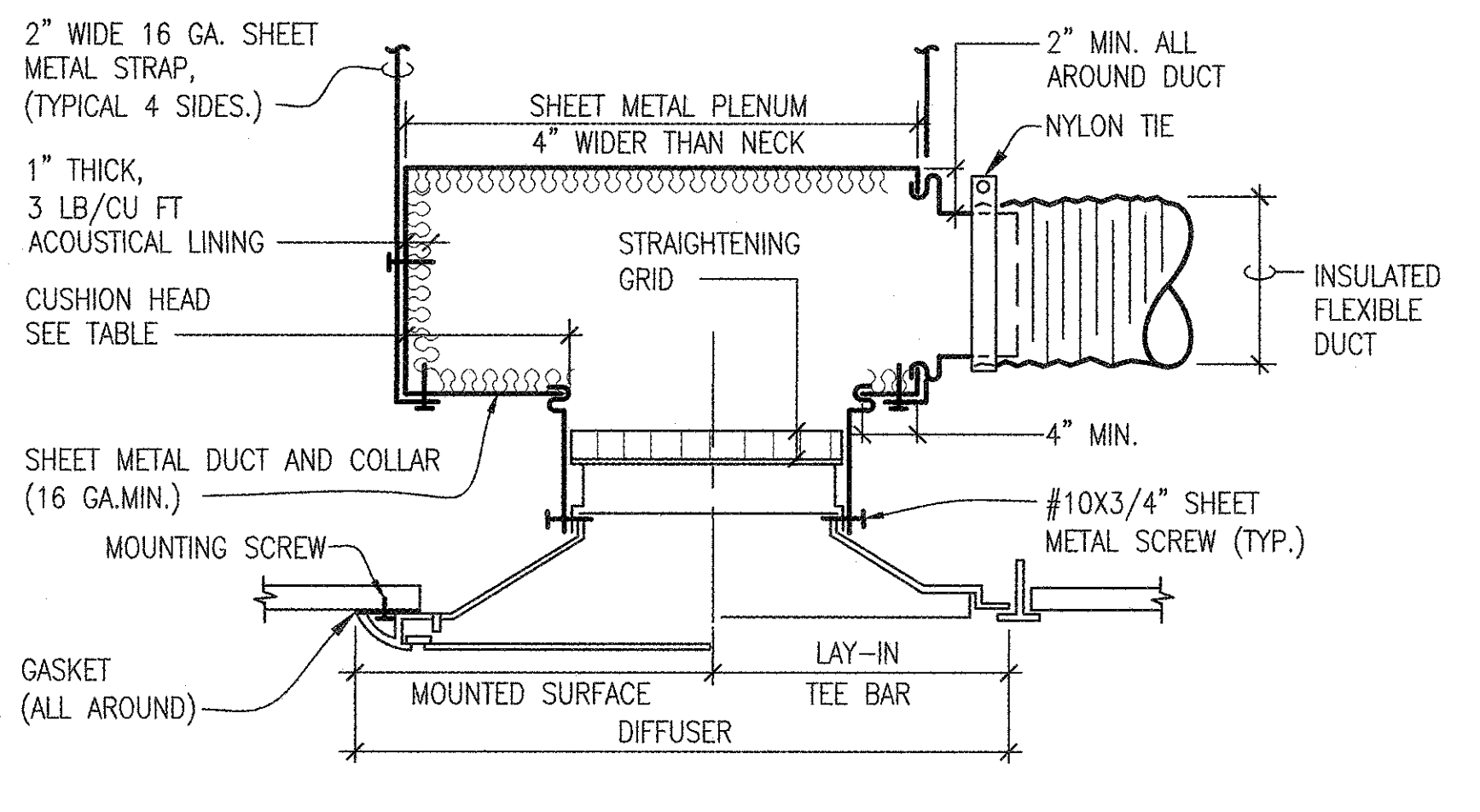
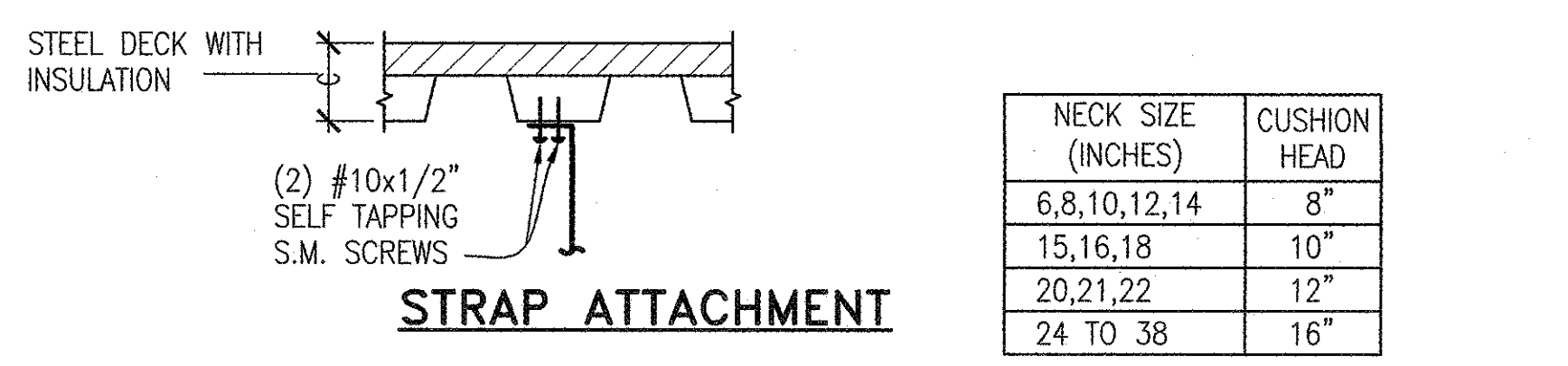

RESTRICTED CLEARANCE CEILING

CEILING DIFFUSER AND GRILLE INSTALLATION N.T.S. 7

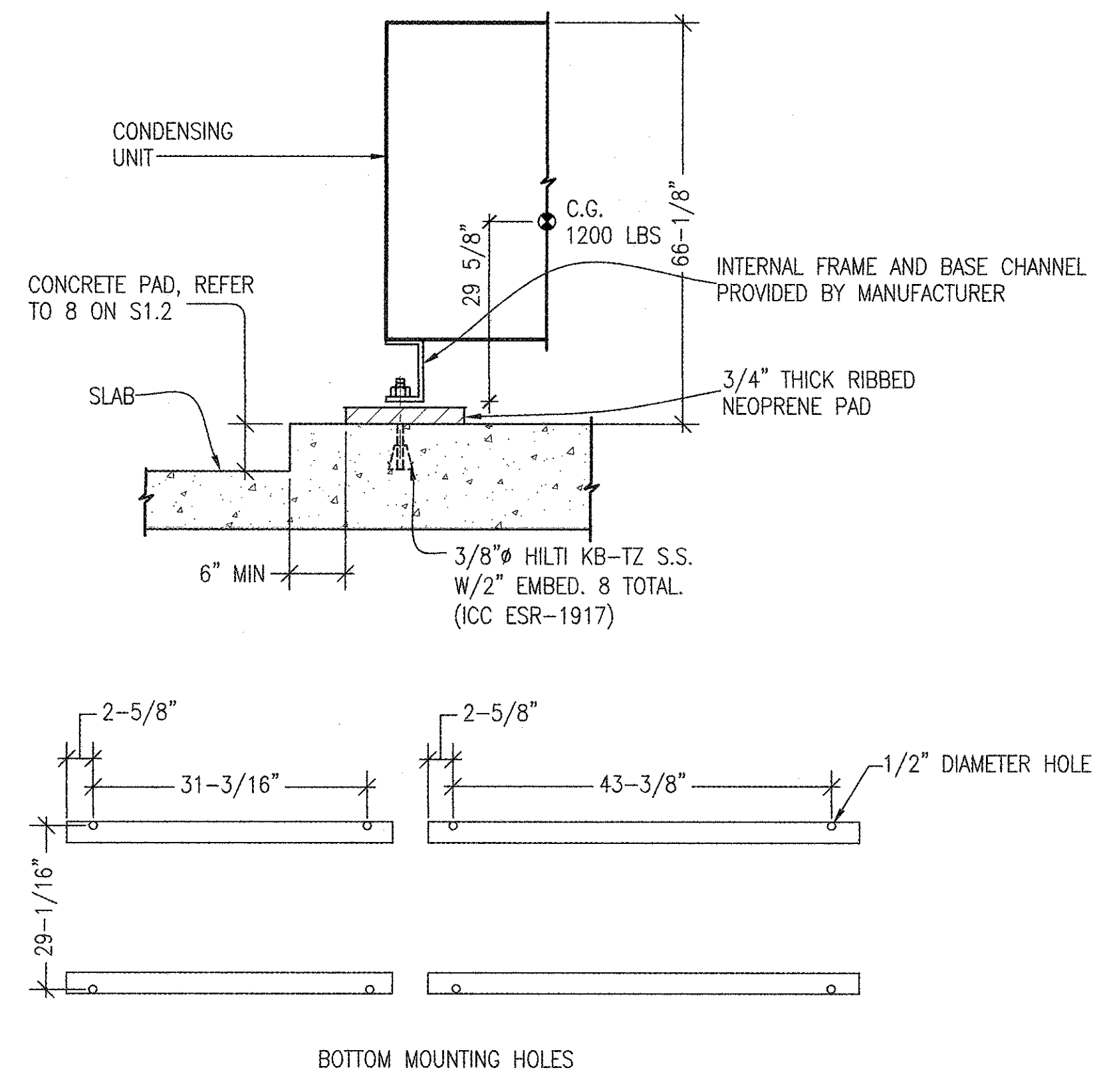

CONDENSING UNIT INSTALLATION N.T.S. 4

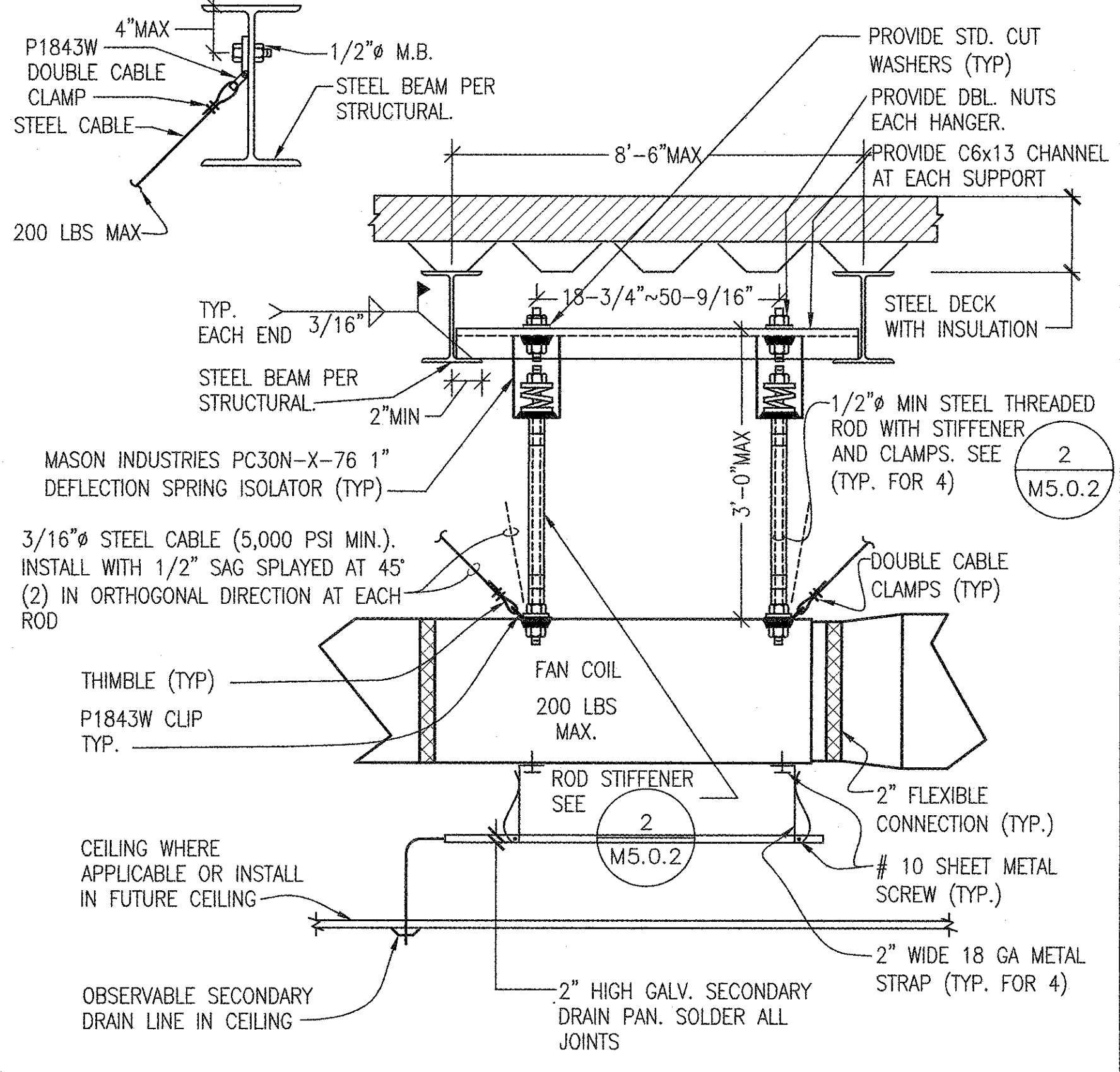

FAN COIL UNIT INSTALLATION N.T.S. 1

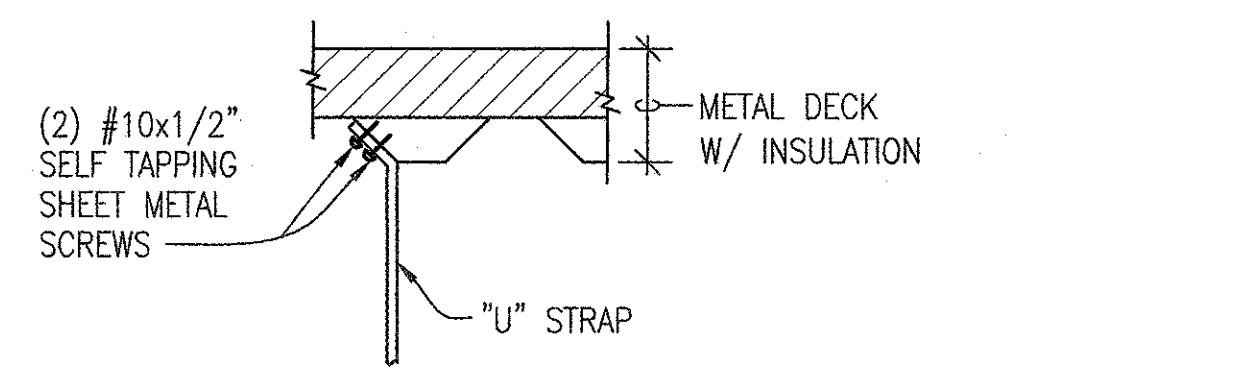

UPPER ATTACHMENT

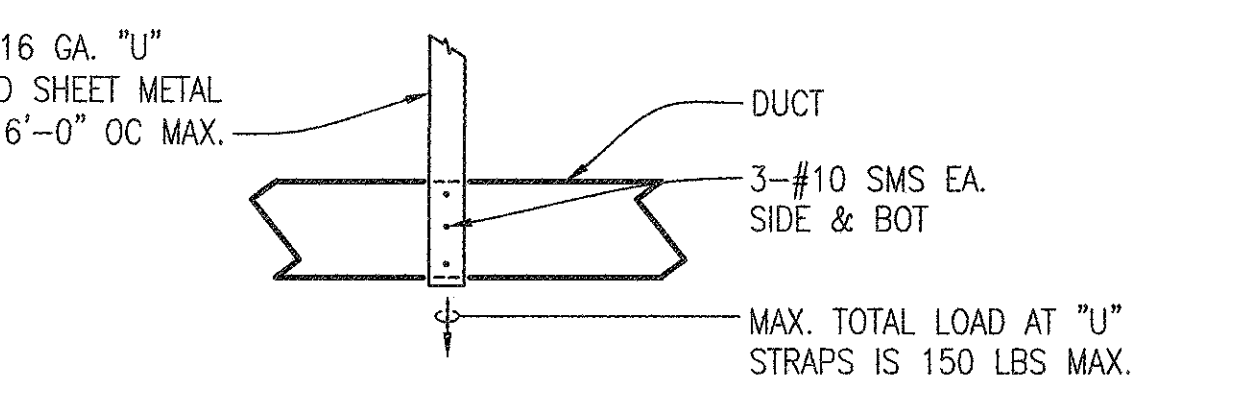

SIDE ELEVATION

- NOTES:**
- SPACING OF DUCT HANGERS SHALL BE 8'-0" ON CENTER.
 - SEISMIC BRACING SHALL BE IN ACCORDANCE WITH SEISMIC RESTRAINT MANUAL CHOSEN TO MEET THE REQUIREMENTS OF SEISMIC BRACING NOTES ON M-001.
 - VERTICAL HANGERS, DIAGONAL AND HORIZONTAL BRACES, BOLT SIZE AND CONNECTION TO STRUCTURAL SUPPORTING MEMBERS, AND SPACING OF BRACING SHALL BE IN ACCORDANCE WITH SEISMIC RESTRAINT MANUAL CHOSEN TO MEET THE REQUIREMENTS OF SEISMIC BRACING NOTES ON M-001 AND AS DETAILED IN THE SEISMIC RESTRAINT MANUAL.

STRAP HANGER N.T.S. 11

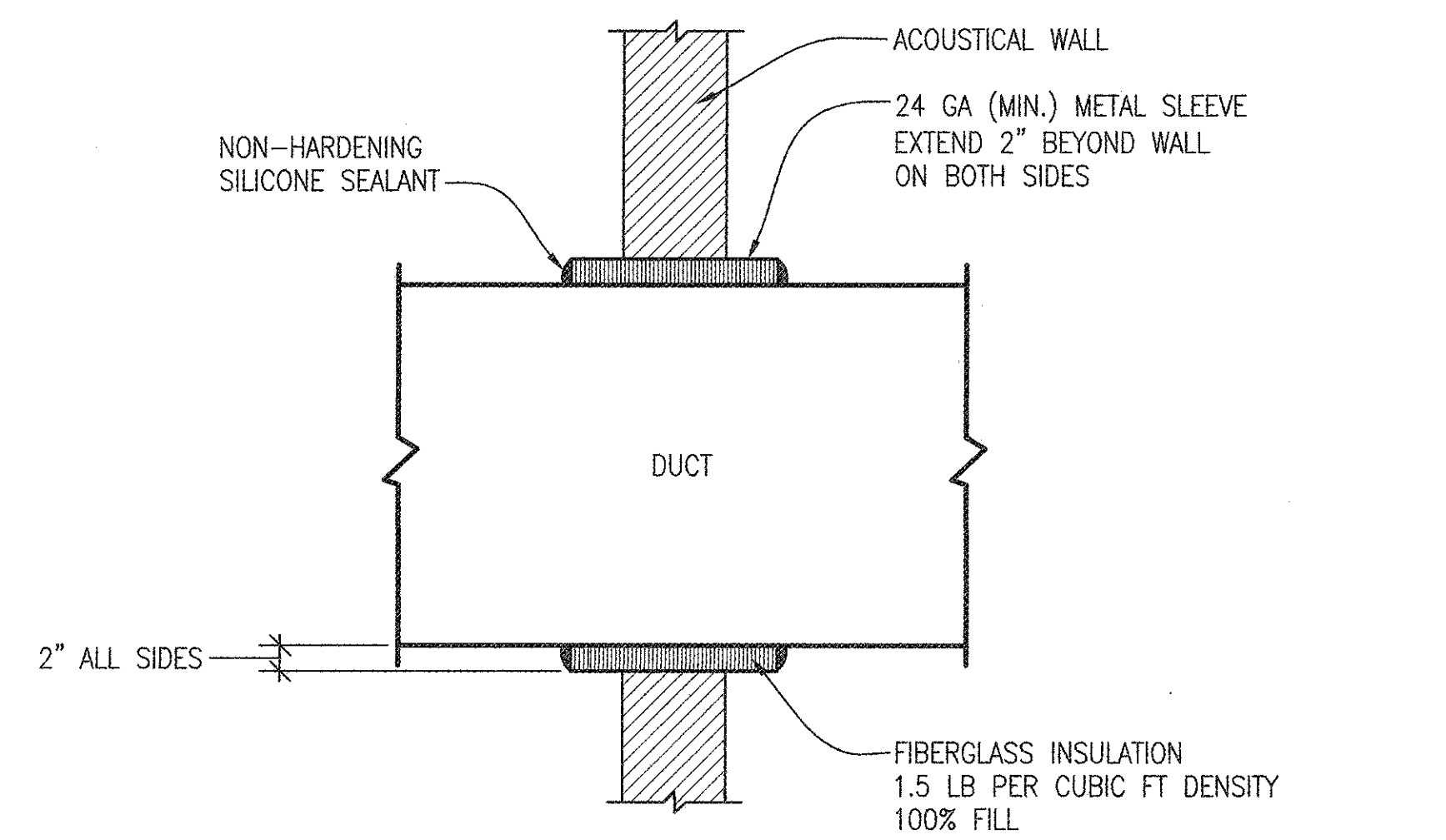

DUCT PENETRATION THROUGH NON-RATED WALL N.T.S. 8

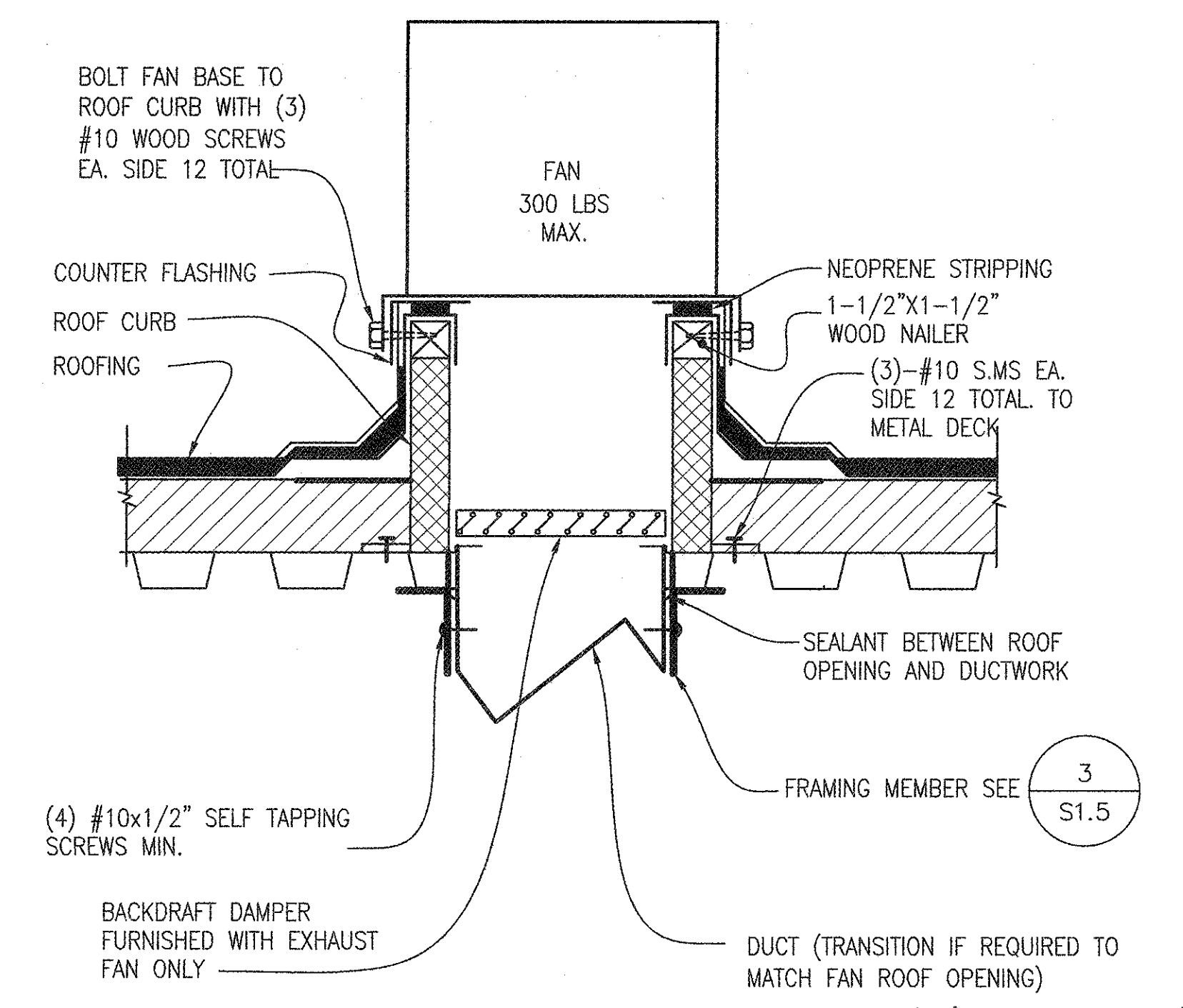

ROOF CURB MOUNTED FAN INSTALLATION N.T.S. 5

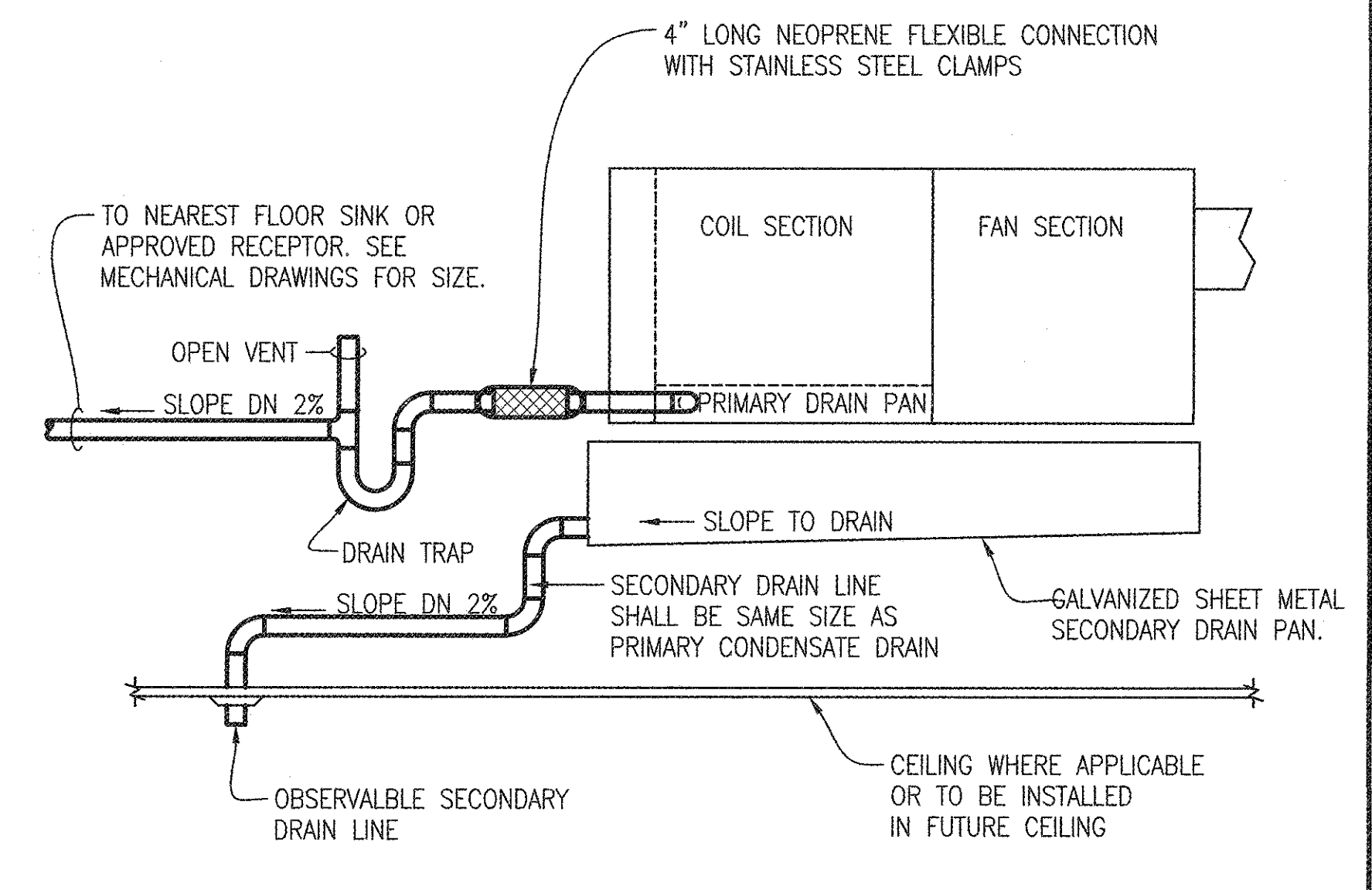

SUSPENDED EQUIPMENT CONDENSATE DRAIN PIPING N.T.S. 2

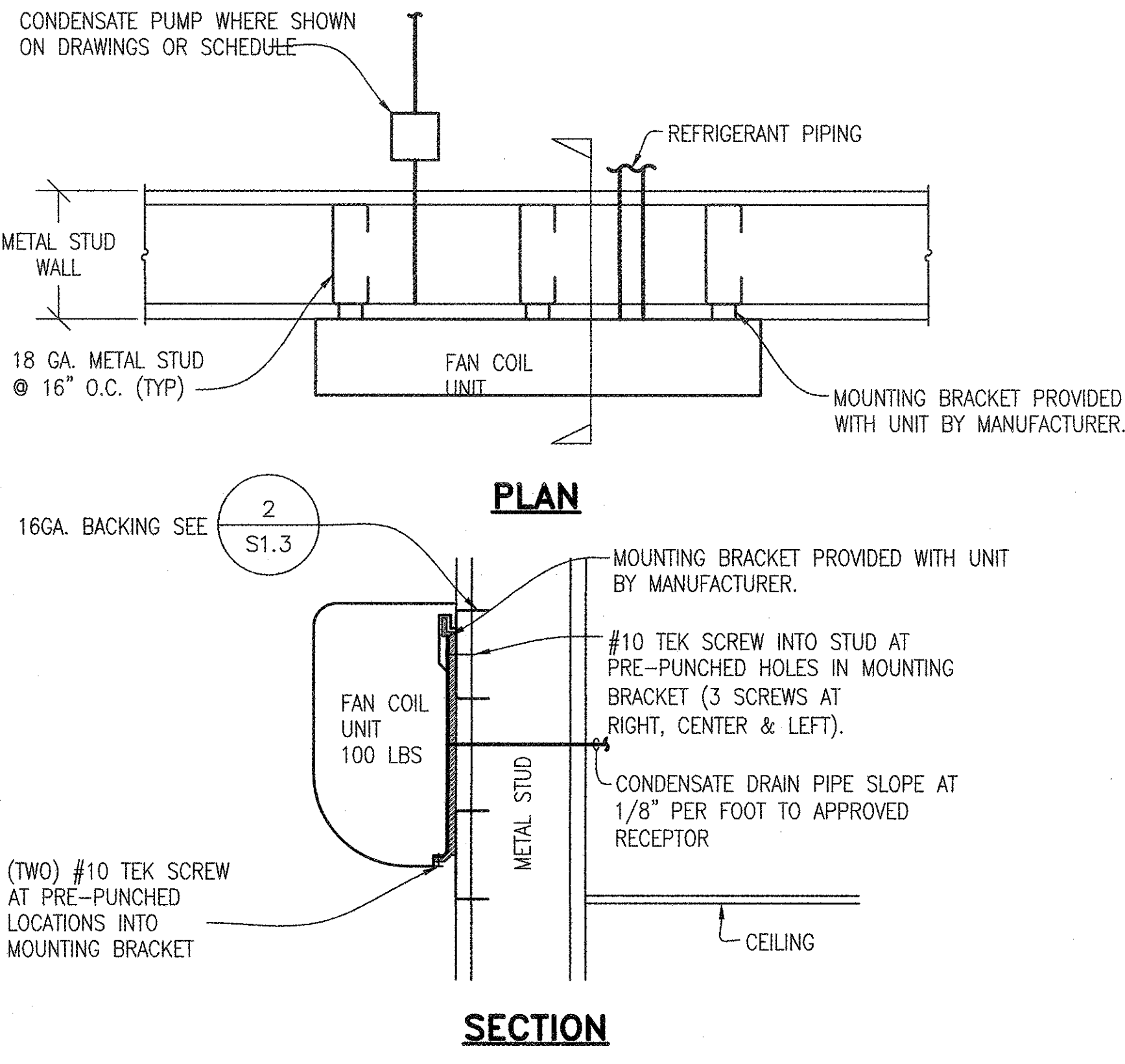

WALL MOUNTED FAN COIL INSTALLATION N.T.S. 9

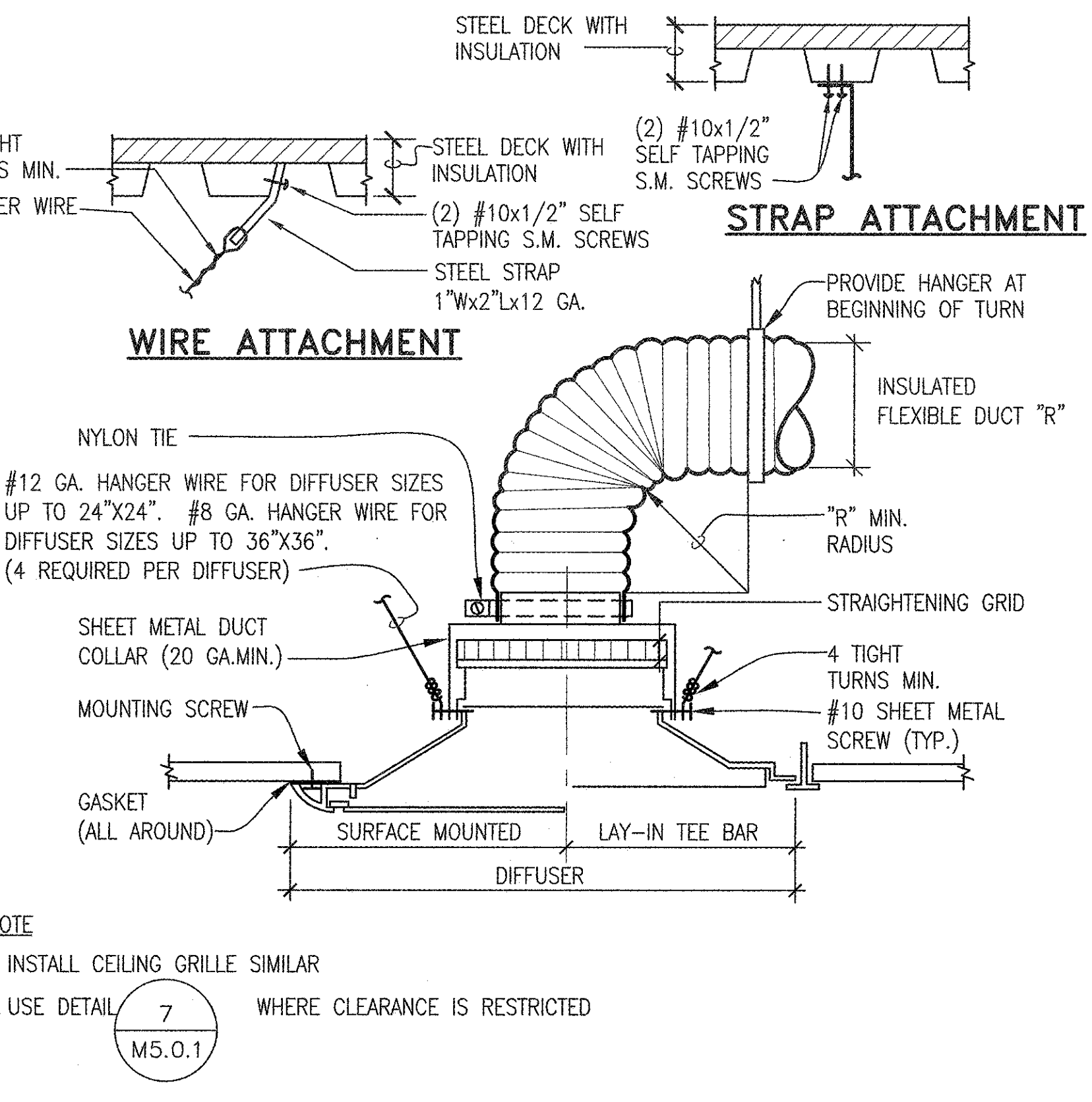

CEILING DIFFUSER AND GRILLE INSTALLATION N.T.S. 6

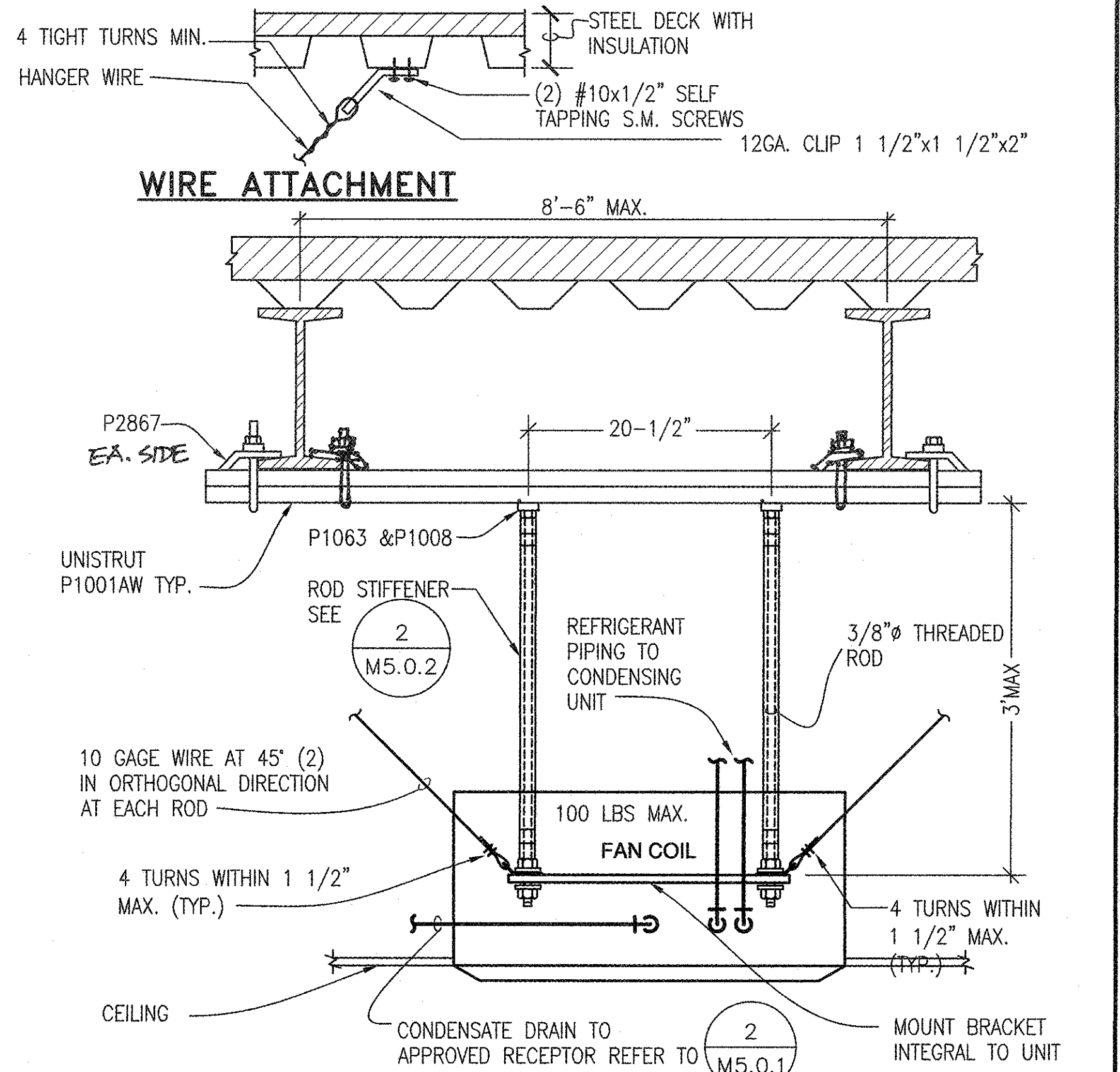

CEILING CASSETTE TYPE FAN COIL INSTALLATION N.T.S. 3

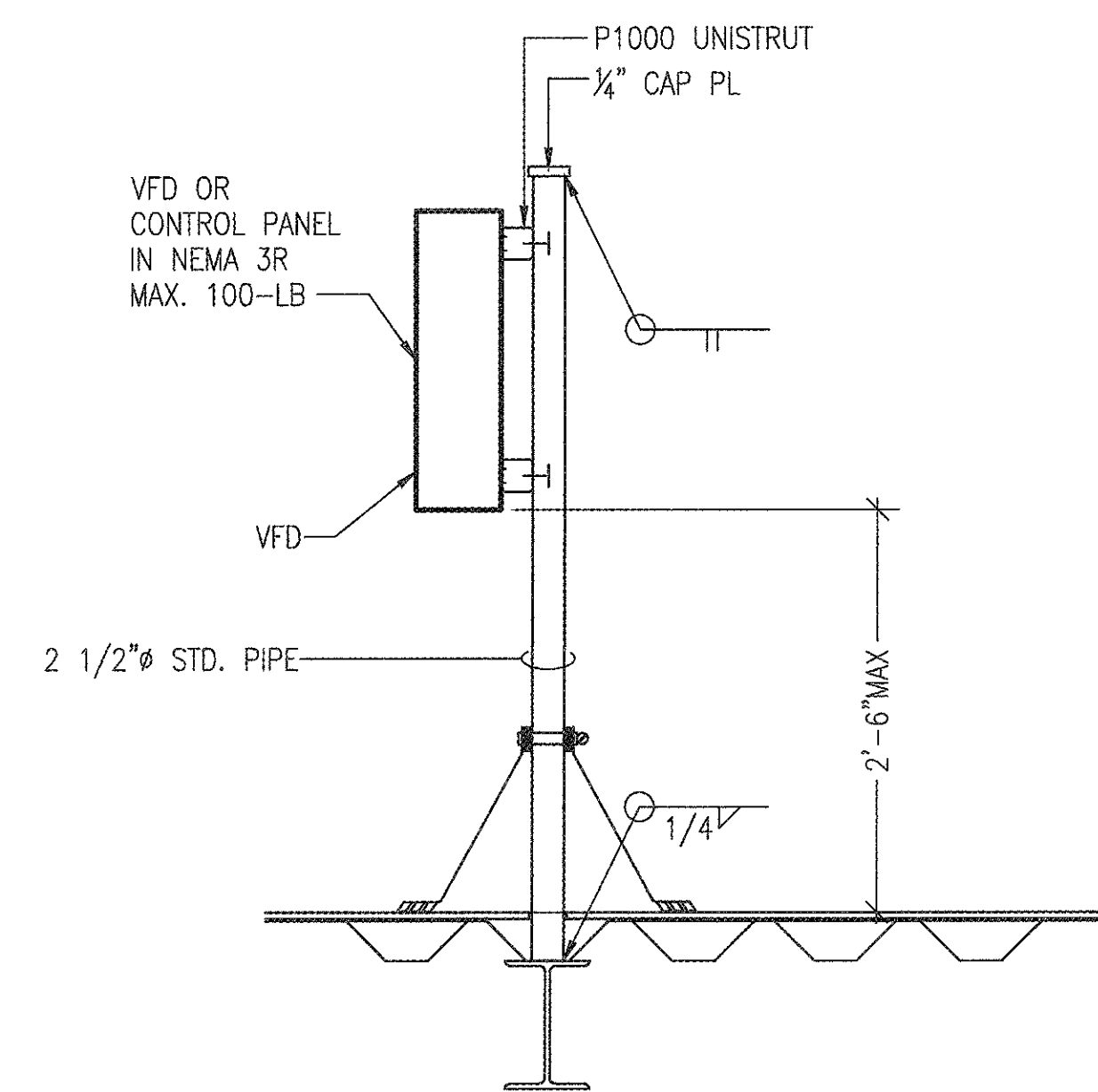
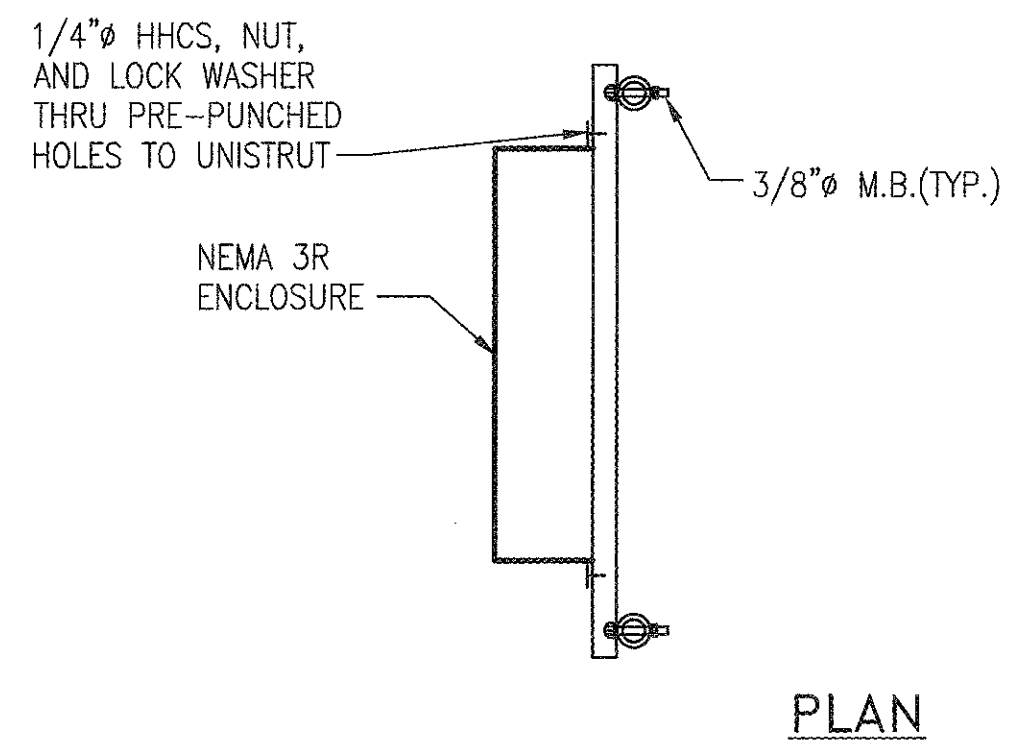

NOTES:
ALL STEEL SHALL BE HOT-DIPPED GALV. OR S.S

N.T.S.

N.T.S.

ROOF MOUNTED VFD OR CONTROL PANEL SUPPORT DETAIL

N.T.S.

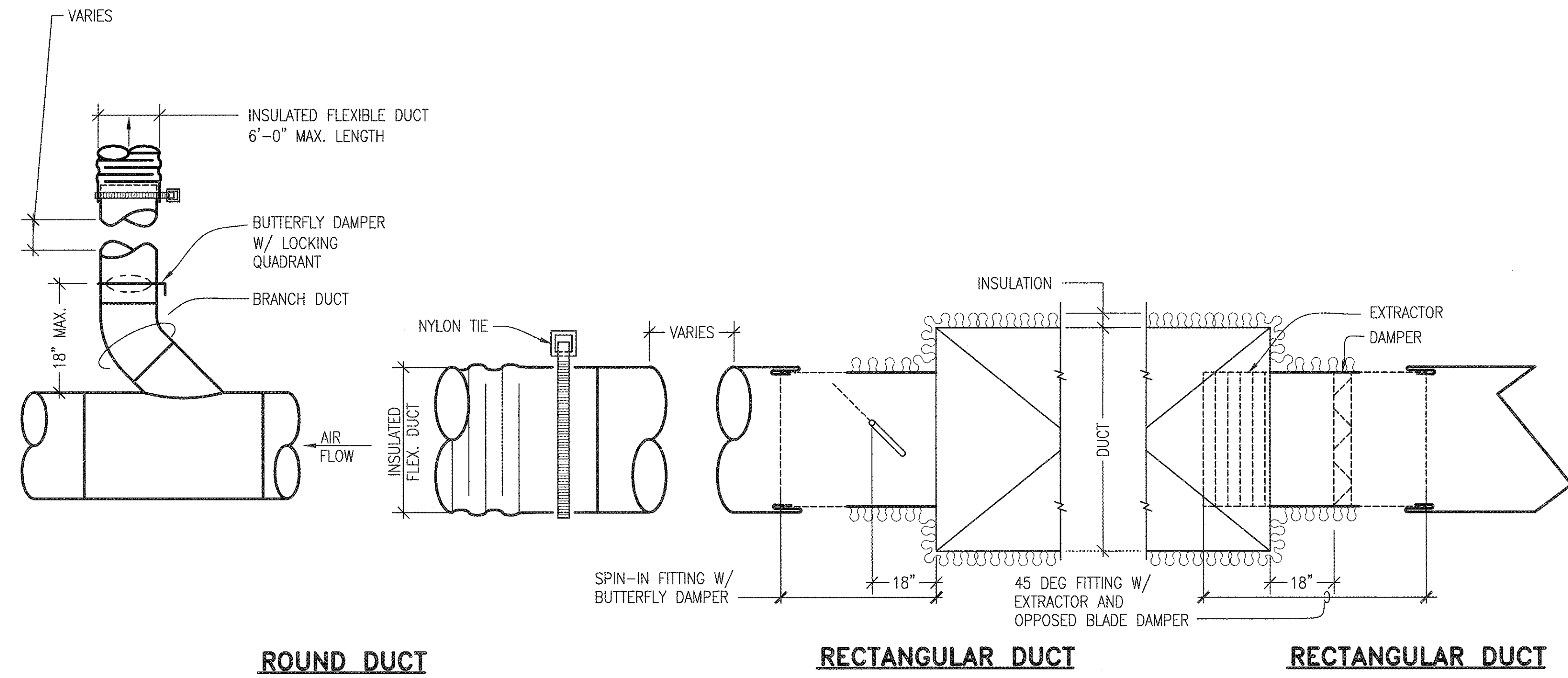

DUCT TAKE-OFFS

N.T.S.

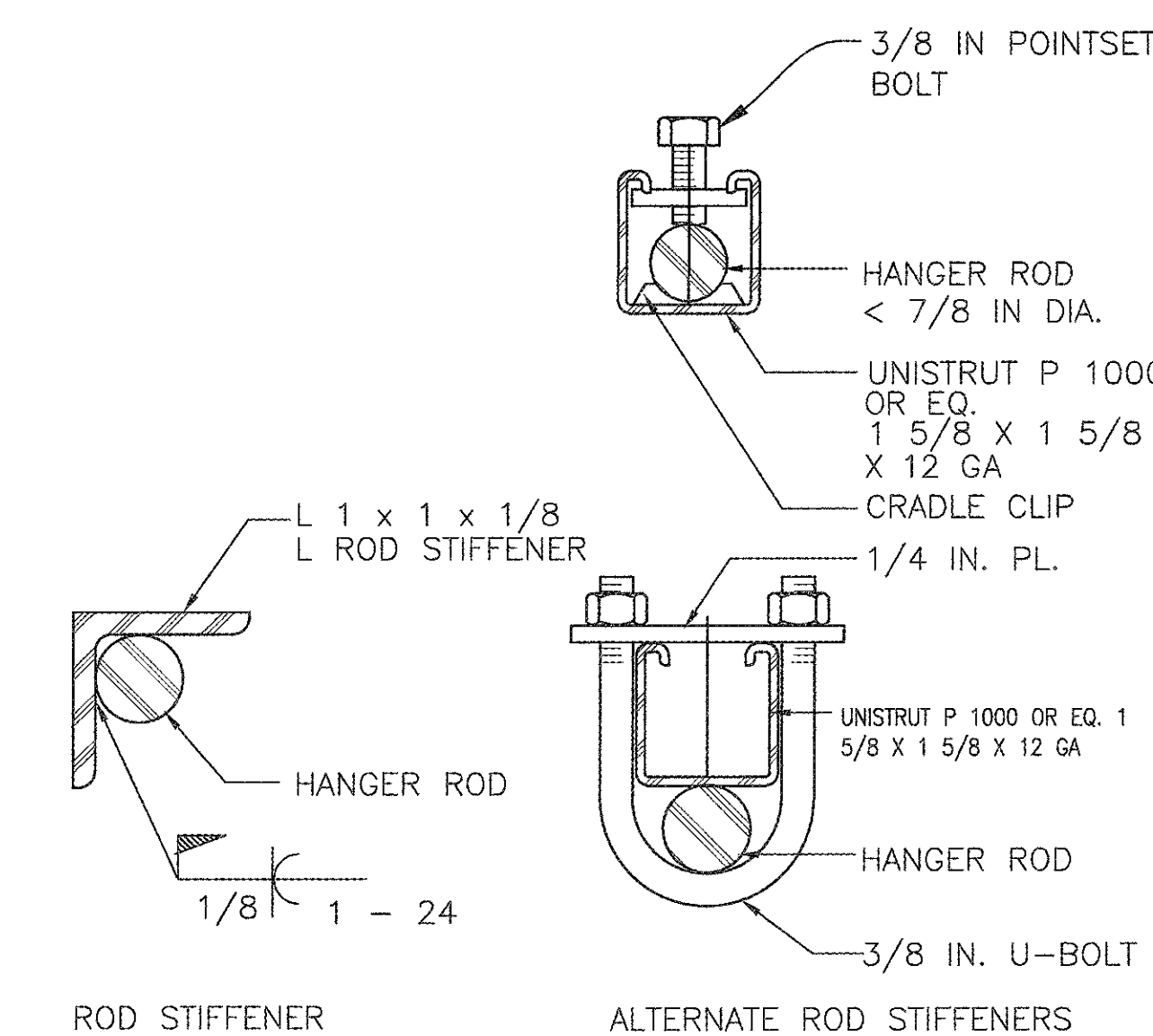

METHODS FOR TYING RODS AND ROD STIFFENERS.

NOTES:
1. COORDINATE PIPE SUPPORT SYSTEM WITH STRUCTURAL.
2. SEE SEISMIC RESTRAINT MANUAL GUIDELINES AS INDICATED ON M0.1 SEISMIC BRACING NOTES FOR MECHANICAL SYSTEMS FOR OTHER HANGER ROD AND BRACING INFORMATION.

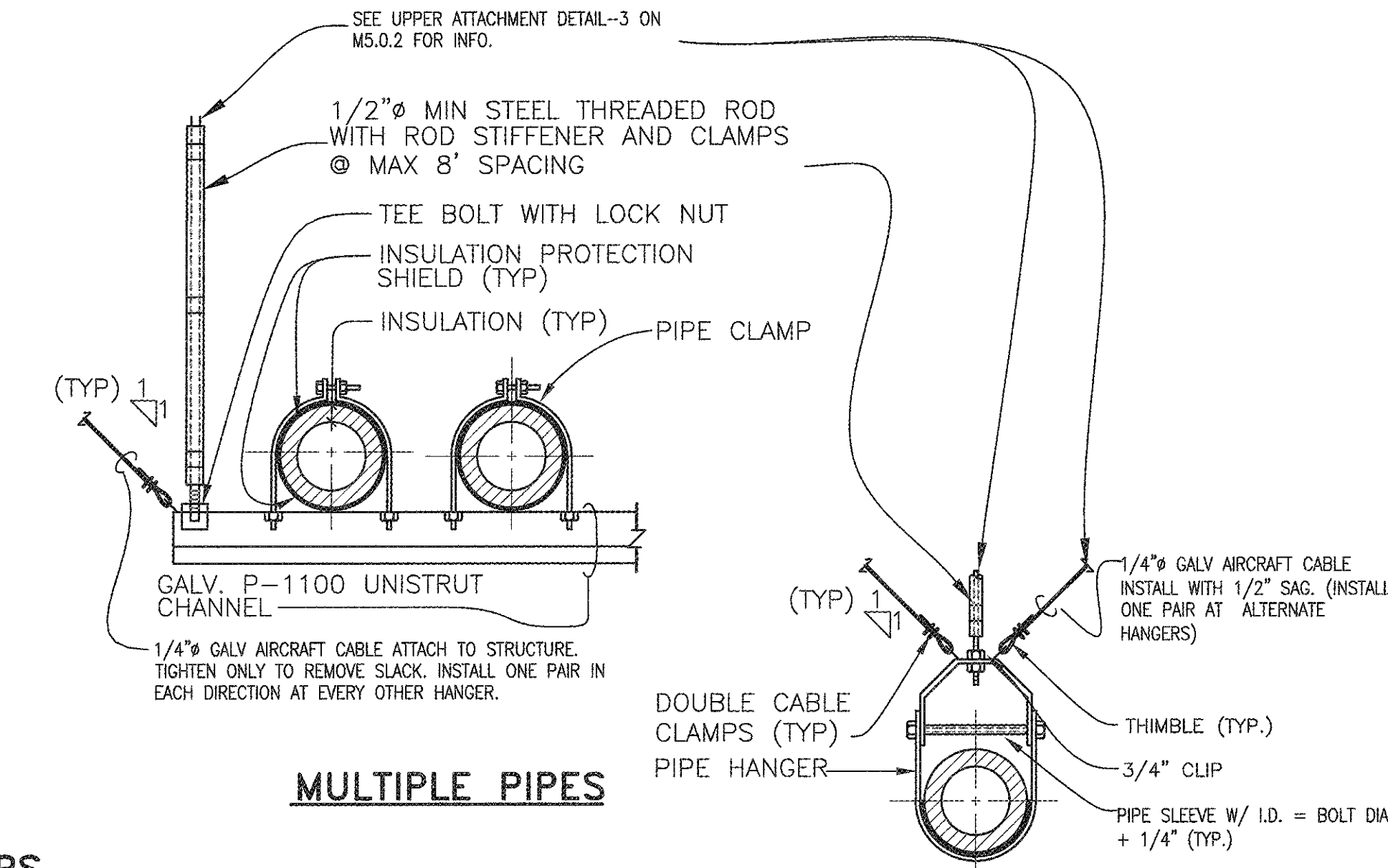

MULTIPLE PIPES

SINGLE PIPE

(300 LBS MAX. TOTAL WEIGHT)

N.T.S.

N.T.S.

N.T.S.

N.T.S.

DIFFUSER WITH CONCRETE CEILING INSTALLATION

N.T.S.

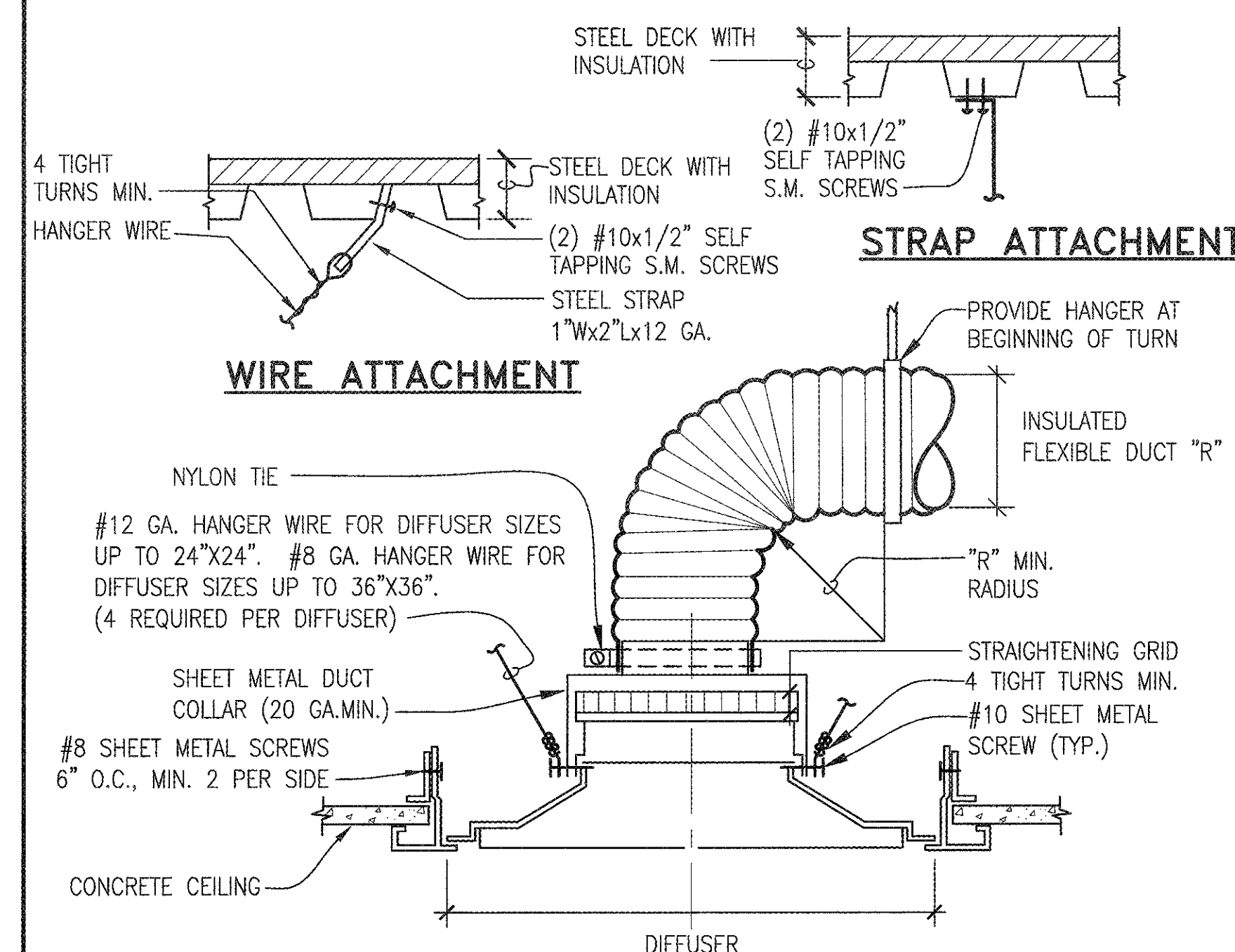

DIFFUSER WITH CONCRETE CEILING INSTALLATION

N.T.S.

PIPE SUPPORT ABOVE CEILING

N.T.S.

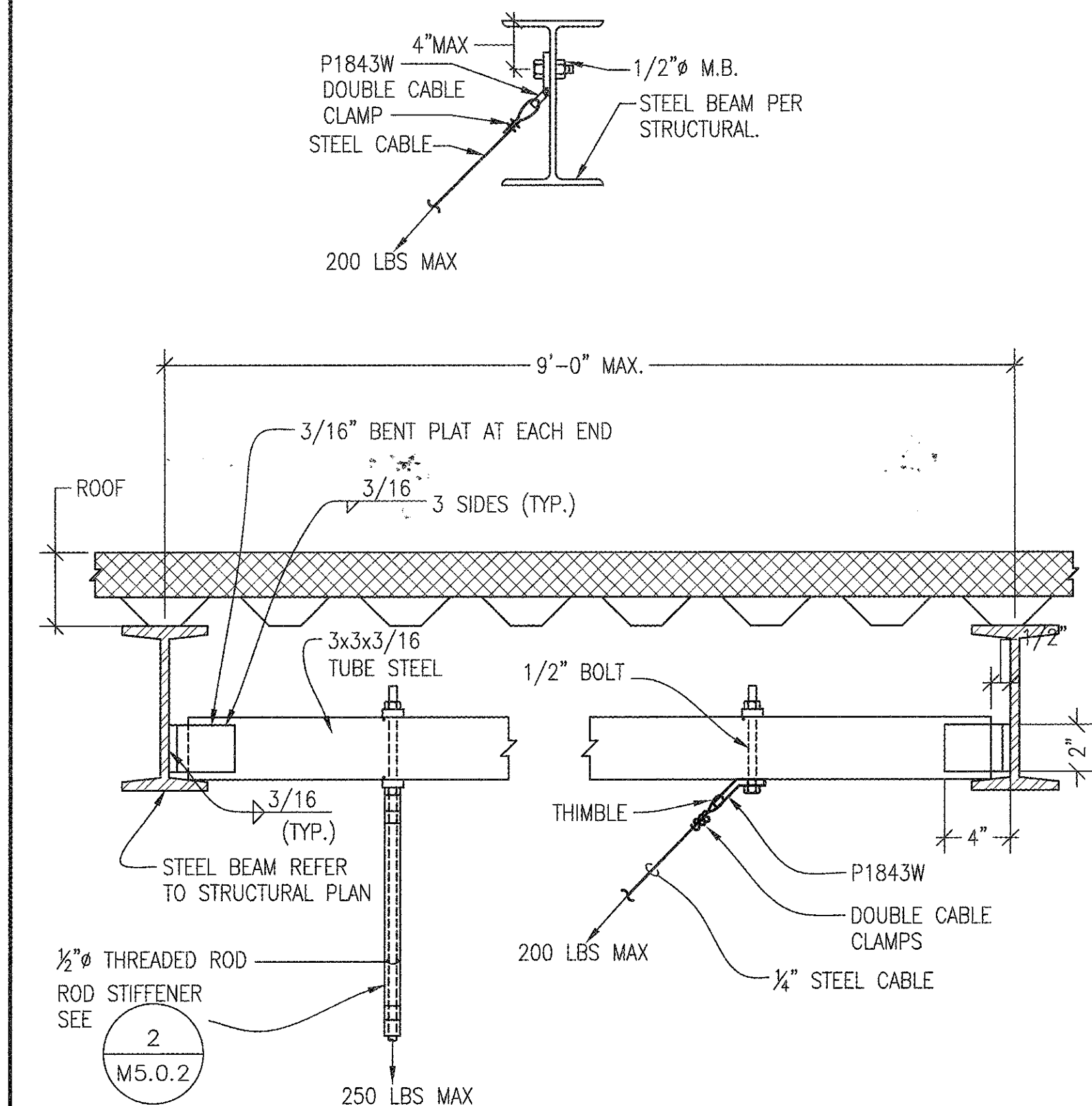

PIPING HANGER UPPER ATTACHMENTS

N.T.S.

N.T.S.

N.T.S.

N.T.S.

N.T.S.

N.T.S.

N.T.S.

N.T.S.

N.T.S.

**COMPTON
CCD**

CAMPUS PUBLIC SAFETY BUILDING

1111 EAST ARTESIA BOULEVARD,
COMPTON CALIFORNIA 90221

ARUB192BTE4
Combi. : ARUB072BTE4,ARUB121BTE4
Additional refrigerant : 20.72 lbs

MCA : 25.3 40.3
MOP : 40 60
V,Hz : 3/208,230V/60Hz

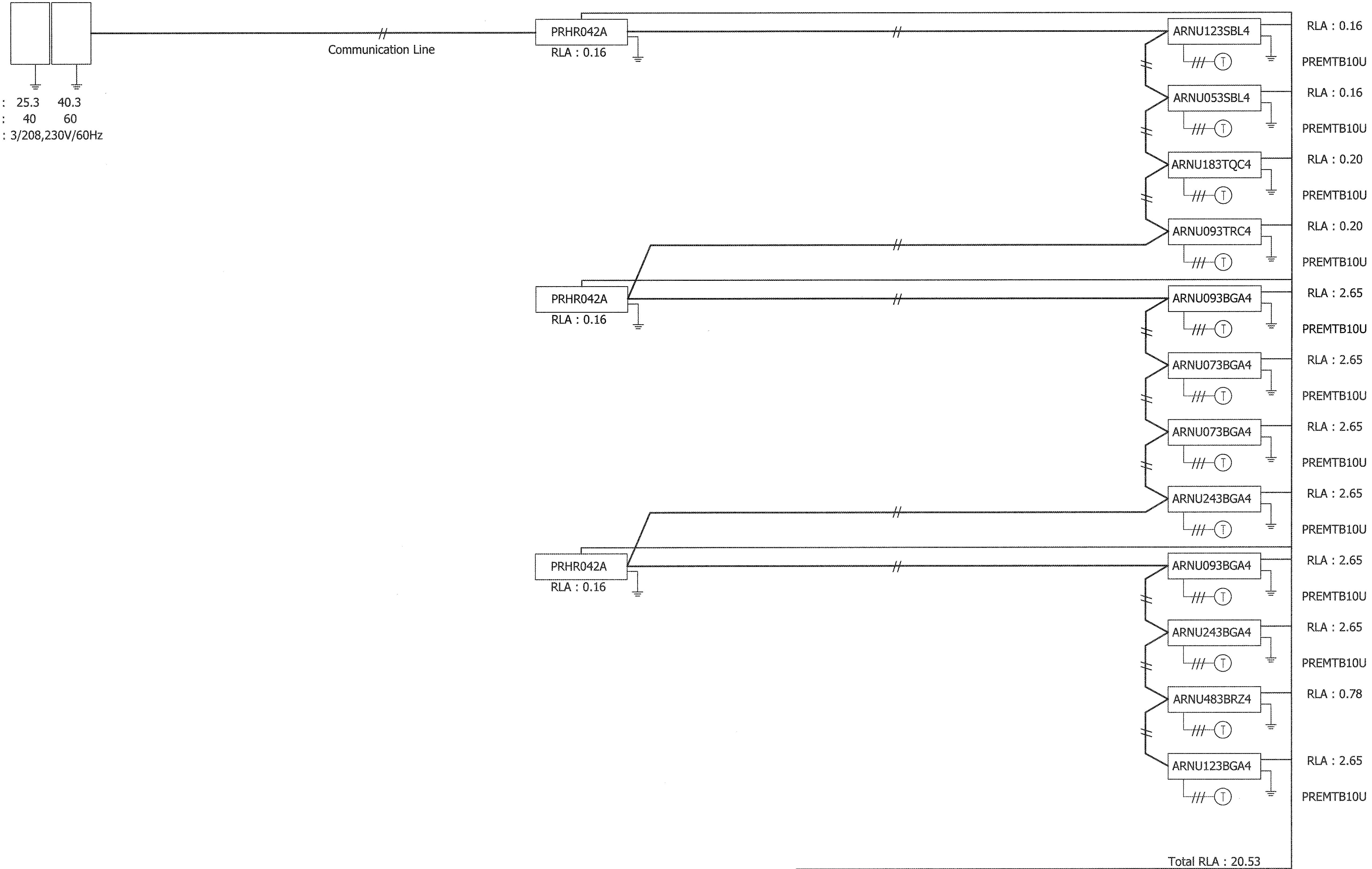

IDENTIFICATION STAMP
DIV. OF THE STATE ARCHITECT
OFFICE OF REGULATION SERVICES
FILE NO: 19-C1
AR: 03-117673
AC: [Signature] SS [Signature]
DATE: DEC 17 2017

16516 dHA + CALPEC
150 S. ARROYO PARKWAY
SUITE NO. 100
PASADENA, CA 91105
TEL: (626) 445-8580
FAX: (626) 445-8081

PRINCIPAL IN CHARGE
KEVIN CHEN
PROJECT MANAGER

DRAWN BY
dHA+CALPEC

NO	REASON	DATE



MECHANICAL CONTROLS

913-4675-01

11/21/16 M6.0.1

SEQUENCE OF OPERATION

- 1. GENERAL**
- A. HVAC SYSTEMS SHALL BE CONTROLLED WITH A DIRECT DIGITAL CONTROL (DDC) ACCORDING TO THE POINTS INDICATED ON THE CONTROL DIAGRAMS, AND SHALL BE STAND-ALONE. ADDITIONAL POINTS (WHETHER HARDWARE OR SOFTWARE POINTS) NOT INDICATED ON THE CONTROL DIAGRAMS BUT ARE REQUIRED TO MEET THE FOLLOWING SEQUENCES OF OPERATION SHALL BE PROVIDED. POINTS INDICATED ON CONTROL DIAGRAMS SHALL BE AVAILABLE FOR PROGRAMMING, TRENDDING, AND REPORTING ON THE DDC SYSTEM AND ITS PC WORKSTATION.
- B. SOFTWARE PROGRAMMING, TRENDDING, REPORTS AND ALARMS SHALL BE PROVIDED TO MEET THE FOLLOWING SEQUENCES OF OPERATION.
- C. CONTROL SETPOINTS, SCHEDULES AND LIMITS SHALL BE ADJUSTABLE.
- D. ACTUATORS FOR VALVES, DAMPERS AND TERMINAL CONTROLLERS SHALL BE ELECTRIC/ELECTRONIC CONTROL.
- E. PUMP AND FAN OPERATION (STATUS) SHALL BE MONITORED BY THE CORRESPONDING CURRENT SENSORS.
- F. CONTROLLERS, RELAYS, TRANSDUCERS, ETC., REQUIRED FOR STAND-ALONE CONTROL SHALL BE HOUSED IN A NEMA 1 ENCLOSURE WITH A SCREW DRIVER LATCH ON DOOR BY CONTROL CONTRACTOR.
- 2. VARIABLE REFRIGERANT FLOW SYSTEMS**
- A. DESCRIPTION:
- THE VARIABLE REFRIGERANT FLOW (VRF) SYSTEM SHALL BE CAPABLE OF PROVIDING SIMULTANEOUS HEATING AND COOLING IN DIFFERENT ZONES. EACH VRF SYSTEM SHALL CONSIST OF AN OUTDOOR CONDENSING UNIT (CU), BRANCH CIRCUIT (BC) CONTROLLER, MULTIPLE INDOOR FAN COIL UNITS (FCU), LOCAL THERMOSTATS, CENTRAL CONTROLLERS, AND SOFTWARE AS REQUIRED.
 - CUs, BCs, FCUs, CENTRAL CONTROLLERS, AND VRF SYSTEM SOFTWARE SHALL BE PROVIDED BY VRF SYSTEM MANUFACTURER.
 - THERMOSTATS SHALL BE MANUFACTURED BY THE VRF SYSTEM MANUFACTURER.
 - THE VRF SYSTEM SHALL INTERFACE TO THE CAMPUS EMS THROUGH THE VRF SYSTEM CONTROLLER. CONTROLS CONTRACTOR AND VRF SYSTEM TECHNICIAN SHALL COORDINATE INTERFACES DURING PREPARATION OF SUBMITTALS.
 - THE VRF SYSTEM SHALL AUTOMATICALLY PERMIT FAN COILS IN DIFFERENT ZONES TO OPERATE IN EITHER HEATING OR COOLING MODE SIMULTANEOUSLY BY PROVIDING HEAT RECOVERY BETWEEN THOSE ZONES VIA THE BC CONTROLLER. EACH FAN COIL SHALL BE CAPABLE OF VARYING REFRIGERANT FLOW TO PROVIDE ADEQUATE HVAC ZONE CONTROL.
- B. START / STOP CONTROL:
- IN RESPONSE TO TIME OF DAY SCHEDULE DEFINED AND CONTROLLED BY THE CAMPUS EMS, FCUs SHALL TRANSITION BETWEEN UNOCCUPIED AND OCCUPIED SETTINGS.
 - OCCUPIED MODE: FCUs SHALL OPERATE IN FAN, HEATING, COOLING, OR AUTO MODES BASED ON COMMAND FROM CENTRAL CONTROLLER TO MAINTAIN PROGRAMMED OCCUPIED SETPOINTS.
 - UNOCCUPIED MODE: FCUs SHALL OPERATE IN FAN HEATING, COOLING, OR AUTO MODES BASED ON COMMAND FROM CENTRAL CONTROLLER TO MAINTAIN PROGRAMMED UNOCCUPIED SETPOINTS.
 - IN RESPONSE TO DOOR / WINDOW SWITCH : FCUs SHALL NOT OPERATE.
 - IN RESPONSE TO OCCUPANCY SENSORS: FCUs SHALL OPERATE IN UNOCCUPIED MODE BASED ON COMMAND FROM CENTRAL CONTROLLER TO MAINTAIN PROGRAMMED UNOCCUPIED SETPOINTS.
- C. ZONE TEMPERATURE CONTROL:
- SETPOINTS:
 - OCCUPIED: 74°F COOLING AND 70°F HEATING
 - UNOCCUPIED: 85°F COOLING AND 55°F HEATING
 - COOLING MODE: THE BC CONTROLLER VALVES ARE POSITIONED TO DIVERT COLD LIQUID REFRIGERANT TO FCUs. THIS FLOW RATE SHALL BE AUTOMATICALLY CONTROLLED BY MODULATING THE FCU LINEAR EXPANSION VALVE TO MATCH THE COOLING LOAD DEMAND. IF TEMPERATURE IN THE SPACE RISES ABOVE THE COOLING SETPOINT, THE FCU SHALL OPERATE IN COOLING MODE. IF TEMPERATURE IN THE SPACE IS BELOW COOLING SETPOINT THE FCU LINEAR EXPANSION VALVE SHALL CLOSE AND RESTRICT REFRIGERANT FLOW AND THE SUPPLY FAN SHALL CONTINUE TO RUN.
 - HEATING MODE: THE BC CONTROLLER VALVES ARE POSITIONED TO DIVERT HOT REFRIGERANT GAS TO FCUs. THIS FLOW RATE SHALL BE AUTOMATICALLY CONTROLLED BY MODULATING THE FCU LINEAR EXPANSION VALVE TO MATCH THE HEATING LOAD DEMAND. IF TEMPERATURE IN THE SPACE FALLS BELOW THE HEATING SETPOINT, THE FCU SHALL OPERATE IN HEATING MODE. IF THE TEMPERATURE IN THE SPACE IS ABOVE THE HEATING SETPOINT, THE FCU LINEAR EXPANSION VALVE WILL CLOSE AND RESTRICT REFRIGERANT FLOW AND THE SUPPLY FAN SHALL CONTINUE TO RUN.
 - AUTOMATIC CHANGEOVER (AUTO) MODE: IN AUTO MODE, THE INDOOR UNIT SHALL AUTOMATICALLY SWITCH BETWEEN AUTO-HEATING AND AUTO-COOLING TO MAINTAIN SPACE TEMPERATURE SETPOINT. THE SWITCH BETWEEN AUTO-HEATING AND AUTO-COOLING SHALL OCCUR WHEN THE SPACE TEMPERATURE RISES OR FALLS 3°F RELATIVE TO SPACE TEMPERATURE SETPOINT. THE BC CONTROLLER VALVES SHALL BE POSITIONED TO DIVERT HOT OR COLD REFRIGERANT TO FCUs BASED ON THE MODE OF THE INDOOR UNIT. THE REFRIGERANT FLOW RATE SHALL BE AUTOMATICALLY CONTROLLED BY MODULATING THE FCU LINEAR EXPANSION VALVE TO MATCH THE HEATING OR COOLING LOAD DEMAND.
 - AUTO-COOLING: WHEN FCU IS IN AUTO-COOLING IT SHALL FUNCTION AS DESCRIBED IN COOLING MODE ABOVE.
 - AUTO-HEATING: WHEN FCU IS IN AUTO-HEATING IT SHALL FUNCTION AS DESCRIBED IN HEATING MODE ABOVE.
- D. VENTILATION: DURING OCCUPIED HOURS, THE OSA DAMPER SHALL BE SET TO PROVIDE MINIMUM VENTILATION AS SCHEDULED ON THE DIRECT EXPANSION FAN COIL UNIT SCHEDULE ON M0.0.2.
- VE-1 SHALL BE PROVEN ON BEFORE START OF FC-1 THROUGH FC-12. IF VE-1 IS NOT ON WHEN ANY ONE OF THESE FCUs IS COMMANDED TO START THEN VE-1 SHALL START.
- E. CONTROLS:
- FCU OPERATION SHALL BE CONTROLLED THROUGH CENTRAL CONTROLLERS AND REMOTELY FROM THE CAMPUS EMS VIA BACNET COMMUNICATION PROTOCOL. OPERATIONAL MODE, TEMPERATURE SETPOINT, FAN SPEED, START/STOP CONTROLL, AND SCHEDULE SHALL BE CONTROLLED IN THIS MANNER.
 - CAMPUS EMS OPERATION AND MONITORING POINTS INCLUDE, BUT ARE NOT LIMITED TO: START/STOP, OPERATION MODE, FAN SPEED, PROHIBIT LOCAL ALARM STATE, ERROR CODE, AND ERROR ADDRESS.
 - TEMPERATURE SETPOINT LIMIT RANGE FOR EACH ZONE SHALL BE DEFINED AND CONTROLLED BY THE CAMPUS EMS.
- F. VRF SYSTEM CONTROL NETWORK:
- THE VRF SYSTEM CONTROL NETWORK (VSCN) SHALL CONSIST OF LOCAL REMOTE AND CENTRAL CONTROLLERS AND/OR INTEGRATED WEB BASED INTERFACE COMMUNICATING OVER A HIGH SPEED COMMUNICATION BUS. THE VSCN SHALL SUPPORT OPERATION MONITORING, SCHEDULING, ERROR AND ALARM REPORTING, ONLINE MAINTENANCE SUPPORT AND INTEGRATION WITH THE CAMPUS EMS USING BACNET INTERFACE.
 - LOCAL REMOTE CONTROLLER (LRC):
 - THE LRC SHALL BE CAPABLE OF CONTROLLING UP TO 16 FCUs (DEFINED AS A GROUP). THE LRC SHALL HAVE LIMITED USER FUNCTIONALITY THAT ALLOWS THE USER TO CHANGE START/STOP, MODE, SETPOINT, AND FAN SPEED. THE LRC SHALL DISPLAY TEMPERATURE IN FAHRENHEIT OR CELSIUS. THE LRC SHALL DISPLAY ERROR CODE IN THE EVENT OF SYSTEM ABNORMALITY OR ERROR.
 - THE LRC SHALL ONLY BE USED IN THE SAME GROUP OR WITH OTHER LRCS WITH UP TO 2 LRCS PER GROUP.
 - THE LRC SHALL REQUIRE NO ADDRESSING AND CONNECT WITH 2-WIRE, STRANDED, NON-POLAR WIRE TO ITS FCU. THE LRC SHALL REQUIRE CROSSOVER WIRING FOR GROUPING TO OTHER FCUs.
 - CENTRAL CONTROLLER:
 - THE CENTRAL CONTROLLER SHALL BE CAPABLE OF CONTROLLING A MAXIMUM OF 50 FCUs ACROSS MULTIPLE CUs. THE CENTRAL CONTROLLER SHALL BE POWERED BY A POWER SUPPLY UNIT PROVIDED BY THE VRF SYSTEM MANUFACTURER. THE CENTRAL CONTROLLER SHALL SUPPORT SYSTEM CONFIGURATION, SCHEDULING, STATUS MONITORING, SETBACK SETTING, INTERLOCK CONFIGURATION, AND ALARM REPORTING.
 - THE CENTRAL CONTROLLER SHALL HAVE 5 BASIC OPERATING CONTROLS WHICH CAN BE APPLIED TO A FCU GROUP OF FCUs, OR ALL FCUs. THE BASIC OPERATING CONTROLS SHALL INCLUDE: START/STOP, MODE, TEMPERATURE SETPOINT, FAN SPEED, AIRFLOW DIRECTION SETTING, AND SCHEDULING. THE BASIC OPERATIONS SHALL BE AS DETERMINED BY THE CAMPUS EMS AND SENT TO CENTRAL CONTROLLER FOR DEPLOYMENT OF OPERATIONS.
 - THE CENTRAL CONTROLLER SHALL BE CAPABLE OF ENABLING OR DISABLING OPERATION OF LRCS.
 - THE CENTRAL CONTROLLER SHALL BE EQUIPPED WITH 1 RJ-45 ETHERNET PORT.
 - BACNET INTEGRATION:
 - THE VSCN SHALL INTERFACE WITH THE CAMPUS EMS. THE VSCN INTERFACE SHALL BE COMPLIANT WITH BACNET PROTOCOL AND CERTIFIED BY THE BACNET TESTING LABORATORIES. THE BACNET INTERFACE SHALL SUPPORT BACNET BROADCAST MANAGEMENT.
- 4. EXHAUST FANS**
- A. RUN CONDITIONS - INTERLOCKED:
- EF-1 SHALL BE INTERLOCKED TO RUN WHENEVER VE-1, VE-3, AND VE-5 RUN UNLESS SHUTDOWN ON SAFETIES.
 - EF-2 SHALL BE INTERLOCKED TO RUN WHENEVER VE-2 AND VE-4 RUN UNLESS SHUTDOWN ON SAFETIES.
- B. FAN: THE FAN SHALL HAVE A USER DEFINABLE (ADJ.) MINIMUM RUNTIME.
- C. EXHAUST AIR DAMPER: THE EXHAUST AIR DAMPER SHALL OPEN ANYTIME THE UNIT RUNS AND SHALL CLOSE ANYTIME THE UNIT STOPS. THE EXHAUST AIR DAMPER SHALL CLOSE 30 SEC (ADJ.) AFTER THE FAN STOPS.
- C. DAMPER STATUS: THE FAN SHALL BE ENABLED AFTER THE DAMPER STATUS HAS PROVEN.
- D. FAN STATUS: THE CONTROLLER SHALL MONITOR THE FAN STATUS.
- E. ALARMS SHALL BE PROVIDED AS FOLLOWS:
- DAMPER FAILURE: COMMANDED OPEN, BUT THE STATUS IS CLOSED.
 - DAMPER IN HAND: COMMANDED CLOSED, BUT THE STATUS IS OPEN.
 - FAN FAILURE: COMMANDED ON, BUT THE STATUS IS OFF.
 - FAN IN HAND: COMMANDED OFF, BUT THE STATUS IS ON.
 - FAN RUNTIME EXCEEDED: FAN STATUS RUNTIME EXCEEDS A USER DEFINABLE LIMIT (ADJ.).
- 5. FAN COIL UNIT (100% OSA)**
- A. RUN CONDITIONS - SCHEDULED: THE UNIT SHALL RUN ACCORDING TO A USER DEFINABLE TIME SCHEDULE TO MATCH BUILDING OPERATION SCHEDULE.
- B. FAN: THE FAN SHALL RUN ANYTIME THE UNIT IS COMMANDED TO RUN, UNLESS SHUTDOWN ON SAFETIES.
- C. TEMPERATURE CONTROL: THE UNIT SHALL MAINTAIN DISCHARGE TEMPERATURE SETPOINT OF 70°F.
- D. HEATING COIL VALVE:
- THE CONTROLLER SHALL MEASURE THE DISCHARGE TEMPERATURE AND MODULATE THE HEATING COIL VALVE TO MAINTAIN SETPOINT.
 - HEATING SHALL BE ENABLED WHENEVER:
 - AND THE DISCHARGE TEMPERATURE IS BELOW SETPOINT.
 - AND OUTSIDE AIR TEMPERATURE IS BELOW 60°F.
 - AND THE FAN IS ON.
- E. FILTER HOURS: THE CONTROLLER SHALL MONITOR THE FAN RUNTIME.
- F. DISCHARGE AIR TEMPERATURE: THE CONTROLLER SHALL MONITOR THE DISCHARGE AIR TEMPERATURE.
- G. FAN STATUS: THE CONTROLLER SHALL MONITOR THE FAN STATUS.
- H. AIRFLOW: THE CONTROLLER SHALL MONITOR THE AIRFLOW.
- I. ALARMS SHALL BE PROVIDED AS FOLLOWS:
- FILTER CHANGE REQUIRED: FILTER HAS BEEN IN USE FOR MORE THAN 2200 HRS (ADJ.).
 - HIGH DISCHARGE AIR TEMP: IF THE DISCHARGE AIR TEMPERATURE IS GREATER THAN 120°F (ADJ.).
 - LOW DISCHARGE AIR TEMP: IF THE DISCHARGE AIR TEMPERATURE IS LESS THAN 40°F (ADJ.).
 - FAN FAILURE: COMMANDED ON, BUT THE STATUS IS OFF.
 - FAN IN HAND: COMMANDED OFF, BUT THE STATUS IS ON.
 - FAN RUNTIME EXCEEDED: FAN STATUS RUNTIME EXCEEDS A USER DEFINABLE LIMIT (ADJ.).
 - FAN VALVE POSITION FAILURE: VALVE FEEDBACK SIGNAL DOES NOT CORRESPOND TO VALVE POSITION.
 - LOW OUTSIDE AIRFLOW: AIRFLOW IS LESS THAN 15% OF SETPOINT.

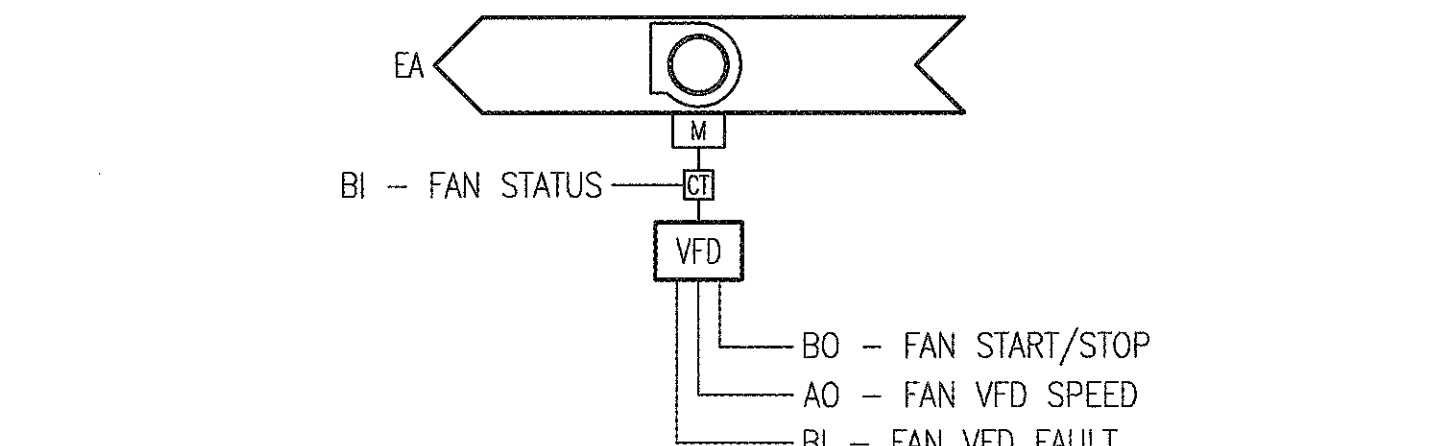

EXHAUST FANS
NOT TO SCALE

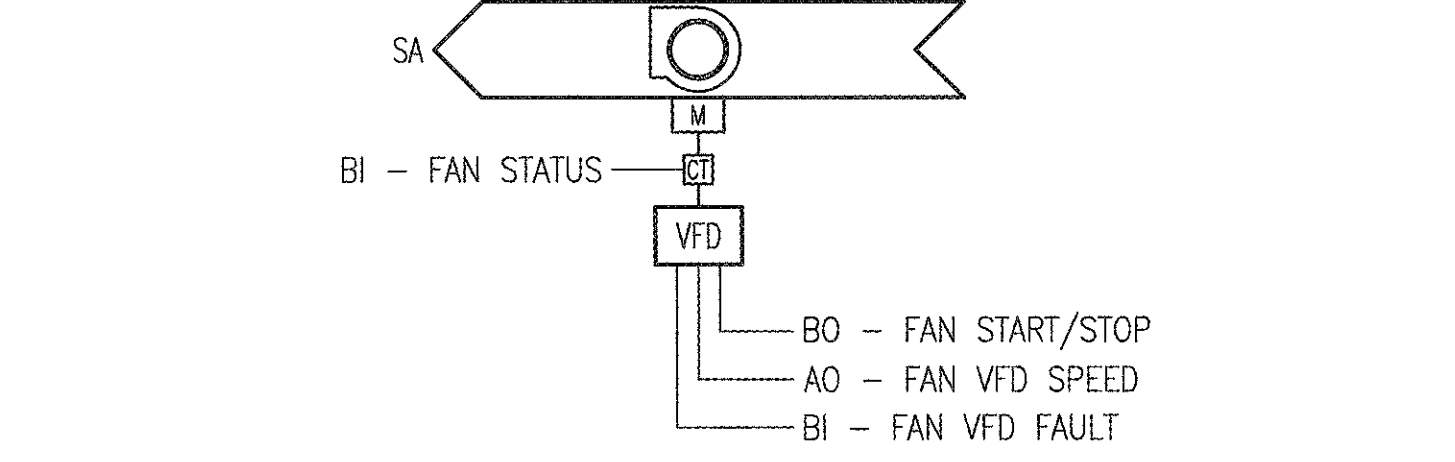

VENTILATION FANS
NOT TO SCALE

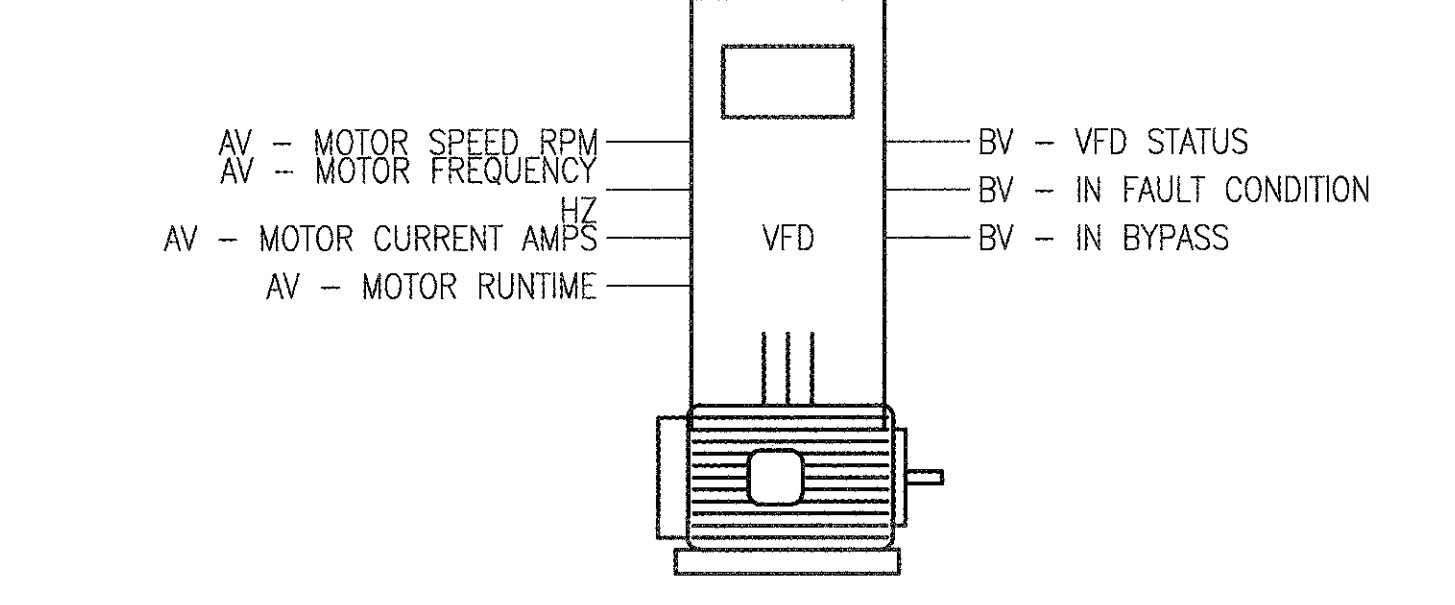

VARIABLE FREQUENCY DRIVE INTERFACE
NOT TO SCALE

CONTROL LEGEND (M-602 ONLY)

SYMBOL	ABBREV.	IDENTIFICATION
		LOW VOLTAGE WIRING IS PROVIDED AND INSTALLED UNDER DIVISION 15 AND CONDUIT IS INSTALLED UNDER DIVISION 16.
	FAN	FAN
	DAMPER - OPPOSED	
	FILTER	
	HOT WATER HEATING COIL	
	CHILLED WATER COOLING COIL	
	PUMP	
	MOTOR	
	MAGNETIC STARTER	
	VFD	VARIABLE FREQUENCY DRIVE
	CT	CURRENT SWITCH
	DSW	DISCONNECT SWITCH
	2-WAY CONTROL VALVE	
	3-WAY CONTROL VALVE	
	TEMPERATURE SENSOR WITH PIPE WELL INSERTION	
	TEMPERATURE SENSOR IN DUCT	
	HUMIDITY SENSOR IN DUCT	
	CARBON DIOXIDE SENSOR IN DUCT	
	TEMPERATURE SENSOR	
	HUMIDITY SENSOR	
	CARBON DIOXIDE SENSOR	
	DIFFERENTIAL PRESSURE SENSOR IN DUCT	
	SD	SMOKE DETECTOR IN DUCT
	DIFFERENTIAL PRESSURE SENSOR IN PIPING OR ACROSS FILTER	
	F	FLOW METER IN PIPING
	FS	FLOW SWITCH IN PIPING
	AF	AIR FLOW SENSOR IN DUCT
	AI	ANALOG INPUT
	AO	ANALOG OUTPUT
	BBDD	BAROMETRIC BACKDRAFT DAMPER
	BI	BINARY INPUT
	BO	BINARY OUTPUT
	CCP	CENTRAL CONTROL PANEL
	DHW	DOMESTIC HOT WATER
	DHWR	DOMESTIC HOT WATER RETURN
	EF	EXHAUST FAN
	N.C.	NORMALLY CLOSED
	N.O.	NORMALLY OPEN
	RF	RETURN FAN
	SF	SUPPLY FAN

CONTROLS NOTES

- CONTROL SYSTEM BASIS OF DESIGN: JOHNSON CONTROLS FX SERIES.
- VERIFY ELECTRICAL CHARACTERISTICS WITH ELECTRICAL PLANS PRIOR TO BID AND MATERIAL PURCHASE.
- CONTROL DIAGRAM IS FUNCTIONAL, SINGLE LINE DIAGRAM. CONTROL CONTRACTOR SHALL SUBMIT DETAILED WIRING DIAGRAM FOR APPROVAL PRIOR TO PURCHASE OR INSTALLATION.
- CONTROL CONTRACTOR SHALL FURNISH AND INSTALL LOW VOLTAGE CONTROL WIRING AND CONDUIT FOR LOW VOLTAGE CONTROL WIRING. ALL LOW VOLTAGE WIRING SHALL BE IN CONDUIT.
- CONTROL CONTRACTOR SHALL COORDINATE, REVIEW AND APPROVE CONTROL RELATED CONDUIT AND JUNCTION BOXES LOCATIONS FOR LINE VOLTAGE WIRING PROVIDED BY ELECTRICAL CONTRACTOR.
- SEE FLOOR PLANS FOR EQUIPMENT QUANTITY AND LOCATION.
- CONTROL PANELS AND UNITARY CONTROLLERS SHALL BE PROVIDED AND INSTALLED AND POWERED BY THE CONTROL CONTRACTOR.
- ELECTRICAL CONTRACTOR SHALL POWER CONTROL PANELS AND UNITARY CONTROLLERS. POWER REQUIREMENTS SHALL BE COORDINATED WITH THE ELECTRICAL CONTRACTOR.

LITTLE
DIVERSIFIED ARCHITECTURAL CONSULTING

1300 Dove Street, Suite 300
Newport Beach, CA 92660
T: 949.698.1400 F: 949.698.1433

www.littleonline.com

This drawing and the design shown are the property of Little Diversified Architectural Consulting. The reproduction, copying or other use of this drawing without their written consent is prohibited and any infringement will be subject to legal action.

© Little 2015

**COMPTON
CCD**

CAMPUS PUBLIC SAFETY BUILDING

1111 EAST ARTESIA BOULEVARD,
COMPTON CALIFORNIA 90221

IDENTIFICATION STAMP
DIV. OF THE STATE ARCHITECT
OFFICE OF REGULATION SERVICES

FILE NO: 19-C1
AR: 03-117673

DATE: Dec 17 2017

16516 dHA + CALPEC

180 S. ARROYO PARKWAY
SUITE NO. 100
PASADENA, CA 91105
TEL: (626) 446-8880
FAX: (626) 446-8081

PRINCIPAL IN CHARGE
KEVIN CHEN

PROJECT MANAGER

DRAWN BY
dHA+CALPEC

NO REASON DATE

REGISTERED PROFESSIONAL ENGINEER
FLUIN S. CHEN
M-3154
Exp. 12/31/17
STATE OF CALIFORNIA

MECHANICAL CONTROLS

913-4675-01

11/21/16 M6.0.2

SEQUENCE OF OPERATION

1. GENERAL

- A. HVAC SYSTEMS SHALL BE CONTROLLED WITH A DIRECT DIGITAL CONTROL (DDC) ACCORDING TO THE POINTS INDICATED ON THE CONTROL DIAGRAMS, AND SHALL BE STAND-ALONE. ADDITIONAL POINTS (WHETHER HARDWARE OR SOFTWARE POINTS) NOT INDICATED ON THE CONTROL DIAGRAMS BUT ARE REQUIRED TO MEET THE FOLLOWING SEQUENCES OF OPERATION SHALL BE PROVIDED. POINTS INDICATED ON CONTROL DIAGRAMS SHALL BE AVAILABLE FOR PROGRAMMING, TRENDRING, AND REPORTING ON THE DDC SYSTEM AND ITS PC WORKSTATION.
- B. SOFTWARE PROGRAMMING, TRENDRING, REPORTS AND ALARMS SHALL BE PROVIDED TO MEET THE FOLLOWING SEQUENCES OF OPERATION.
- C. CONTROL SETPOINTS, SCHEDULES AND LIMITS SHALL BE ADJUSTABLE.
- D. ACTUATORS FOR VALVES, DAMPERS AND TERMINAL CONTROLLERS SHALL BE ELECTRIC/ELECTRONIC CONTROL.
- E. PUMP AND FAN OPERATION (STATUS) SHALL BE MONITORED BY THE CORRESPONDING CURRENT SENSORS.
- F. CONTROLLERS, RELAYS, TRANSDUCERS, ETC., REQUIRED FOR STAND-ALONE CONTROL SHALL BE HOUSED IN A NEMA 1 ENCLOSURE WITH A SCREW DRIVER LATCH ON DOOR BY CONTROL CONTRACTOR.

2. VARIABLE REFRIGERANT FLOW SYSTEMS

- A. DESCRIPTION:
 - 1) THE VARIABLE REFRIGERANT FLOW (VRF) SYSTEM SHALL BE CAPABLE OF PROVIDING SIMULTANEOUS HEATING AND COOLING IN DIFFERENT ZONES. EACH VRF SYSTEM SHALL CONSIST OF AN OUTDOOR CONDENSING UNIT (CU), BRANCH CIRCUIT (BC) CONTROLLER, MULTIPLE INDOOR FAN COIL UNITS (FCU), LOCAL THERMOSTATS, CENTRAL CONTROLLERS, AND SOFTWARE AS REQUIRED.
 - a) CUs, BCs, FCUs, CENTRAL CONTROLLERS, AND VRF SYSTEM SOFTWARE SHALL BE PROVIDED BY VRF SYSTEM MANUFACTURER.
 - b) THERMOSTATS SHALL BE MANUFACTURED BY THE VRF SYSTEM MANUFACTURER.
 - c) THE VRF SYSTEM SHALL INTERFACE TO THE CAMPUS EMS THROUGH THE VRF SYSTEM CONTROLLER. CONTROLS CONTRACTOR AND VRF SYSTEM TECHNICIAN SHALL COORDINATE INTERFACES DURING PREPARATION OF SUBMITTALS.
 - 2) THE VRF SYSTEM SHALL AUTOMATICALLY PERMIT FAN COILS IN DIFFERENT ZONES TO OPERATE IN EITHER HEATING OR COOLING MODE SIMULTANEOUSLY BY PROVIDING HEAT RECOVERY BETWEEN THOSE ZONES VIA THE BC CONTROLLER. EACH FAN COIL SHALL BE CAPABLE OF VARYING REFRIGERANT FLOW TO PROVIDE ADEQUATE HVAC ZONE CONTROL.
- B. START / STOP CONTROL:
 - 1) IN RESPONSE TO TIME OF DAY SCHEDULE DEFINED AND CONTROLLED BY THE CAMPUS EMS, FCUs SHALL TRANSITION BETWEEN UNOCCUPIED AND OCCUPIED SETTINGS.
 - a) OCCUPIED MODE: FCUs SHALL OPERATE IN FAN, HEATING, COOLING, OR AUTO MODES BASED ON COMMAND FROM CENTRAL CONTROLLER TO MAINTAIN PROGRAMMED OCCUPIED SETPOINTS.
 - b) UNOCCUPIED MODE: FCUs SHALL OPERATE IN FAN HEATING, COOLING, OR AUTO MODES BASED ON COMMAND FROM CENTRAL CONTROLLER TO MAINTAIN PROGRAMMED UNOCCUPIED SETPOINTS.
 - 2) IN RESPONSE TO DOOR / WINDOW SWITCH : FCUs SHALL NOT OPERATE.
 - 3) IN RESPONSE TO OCCUPANCY SENSORS: FCUs SHALL OPERATE IN UNOCCUPIED MODE BASED ON COMMAND FROM CENTRAL CONTROLLER TO MAINTAIN PROGRAMMED UNOCCUPIED SETPOINTS.
- C. ZONE TEMPERATURE CONTROL:
 - 1) SETPOINTS:
 - a) OCCUPIED: 74°F COOLING AND 70°F HEATING
 - b) UNOCCUPIED: 85°F COOLING AND 55°F HEATING
 - 2) COOLING MODE: THE BC CONTROLLER VALVES ARE POSITIONED TO DIVERT COLD LIQUID REFRIGERANT TO FCUs. THIS FLOW RATE SHALL BE AUTOMATICALLY CONTROLLED BY MODULATING THE FCU LINEAR EXPANSION VALVE TO MATCH THE COOLING LOAD DEMAND. IF TEMPERATURE IN THE SPACE RISES ABOVE THE COOLING SETPOINT, THE FCU SHALL OPERATE IN COOLING MODE. IF TEMPERATURE IN THE SPACE IS BELOW COOLING SETPOINT THE FCU LINEAR EXPANSION VALVE SHALL CLOSE AND RESTRICT REFRIGERANT FLOW AND THE SUPPLY FAN SHALL CONTINUE TO RUN.
 - 3) HEATING MODE: THE BC CONTROLLER VALVES ARE POSITIONED TO DIVERT HOT REFRIGERANT GAS TO FCUs. THIS FLOW RATE SHALL BE AUTOMATICALLY CONTROLLED BY MODULATING THE FCU LINEAR EXPANSION VALVE TO MATCH THE HEATING LOAD DEMAND. IF TEMPERATURE IN THE SPACE FALLS BELOW THE HEATING SETPOINT, THE FCU SHALL OPERATE IN HEATING MODE. IF THE TEMPERATURE IN THE SPACE IS ABOVE THE HEATING SETPOINT, THE FCU LINEAR EXPANSION VALVE WILL CLOSE AND RESTRICT REFRIGERANT FLOW AND THE SUPPLY FAN SHALL CONTINUE TO RUN.
 - 4) AUTOMATIC CHANGEOVER (AUTO) MODE: IN AUTO MODE, THE INDOOR UNIT SHALL AUTOMATICALLY SWITCH BETWEEN AUTO-HEATING AND AUTO-COOLING TO MAINTAIN SPACE TEMPERATURE SETPOINT. THE SWITCH BETWEEN AUTO-HEATING AND AUTO-COOLING SHALL OCCUR WHEN THE SPACE TEMPERATURE RISES OR FALLS 3°F RELATIVE TO SPACE TEMPERATURE SETPOINT. THE BC CONTROLLER VALVES SHALL BE POSITIONED TO DIVERT HOT OR COLD REFRIGERANT TO FCUs BASED ON THE MODE OF THE INDOOR UNIT. THE REFRIGERANT FLOW RATE SHALL BE AUTOMATICALLY CONTROLLED BY MODULATING THE FCU LINEAR EXPANSION VALVE TO MATCH THE HEATING OR COOLING LOAD DEMAND.
 - a) AUTO-COOLING: WHEN FCU IS IN AUTO-COOLING IT SHALL FUNCTION AS DESCRIBED IN COOLING MODE ABOVE.
 - b) AUTO-HEATING: WHEN FCU IS IN AUTO-HEATING IT SHALL FUNCTION AS DESCRIBED IN HEATING MODE ABOVE.
- D. VENTILATION: DURING OCCUPIED HOURS, THE OSA DAMPER SHALL BE SET TO PROVIDE MINIMUM VENTILATION AS SCHEDULED ON THE DIRECT EXPANSION FAN COIL UNIT SCHEDULE ON MO.0.2.
 - 1) VF-1 SHALL BE PROVEN ON BEFORE START OF FC-1 THROUGH FC-12. IF VF-1 IS NOT ON WHEN ANY ONE OF THESE FCUs IS COMMANDED TO START THEN VF-1 SHALL START.

E. CONTROLS:

- 1) FCU OPERATION SHALL BE CONTROLLED THROUGH CENTRAL CONTROLLERS AND REMOTELY FROM THE CAMPUS EMS VIA BACNET COMMUNICATION PROTOCOL. OPERATIONAL MODE, TEMPERATURE SETPOINT, FAN SPEED, START/STOP CONTROLL, AND SCHEDULE SHALL BE CONTROLLED IN THIS MANNER.
 - 2) CAMPUS EMS OPERATION AND MONITORING POINTS INCLUDE, BUT ARE NOT LIMITED TO: START/STOP, OPERATION MODE, FAN SPEED, PROHIBIT LOCAL ALARM STATE, ERROR CODE, AND ERROR ADDRESS.
 - 3) TEMPERATURE SETPOINT LIMIT RANGE FOR EACH ZONE SHALL BE DEFINED AND CONTROLLED BY THE CAMPUS EMS.
- F. VRF SYSTEM CONTROL NETWORK:
- 1) THE VRF SYSTEM CONTROL NETWORK (VSCN) SHALL CONSIST OF LOCAL REMOTE AND CENTRAL CONTROLLERS AND/OR INTEGRATED WEB BASED INTERFACE COMMUNICATING OVER A HIGH SPEED COMMUNICATION BUS. THE VSCN SHALL SUPPORT OPERATION MONITORING, SCHEDULING, ERROR AND ALARM REPORTING, ONLINE MAINTENANCE SUPPORT AND INTEGRATION WITH THE CAMPUS EMS USING BACNET INTERFACE.
 - 2) LOCAL REMOTE CONTROLLER (LRC):
 - a) THE LRC SHALL BE CAPABLE OF CONTROLLING UP TO 16 FCUs (DEFINED AS A GROUP). THE LRC SHALL HAVE LIMITED USER FUNCTIONALITY THAT ALLOWS THE USER TO CHANGE START/STOP, MODE, SETPOINT, AND FAN SPEED. THE LRC SHALL DISPLAY TEMPERATURE IN FAHRENHEIT OR CELSIUS. THE LRC SHALL DISPLAY ERROR CODE IN THE EVENT OF SYSTEM ABNORMALITY OR ERROR.
 - b) THE LRC SHALL ONLY BE USED IN THE SAME GROUP OR WITH OTHER LRCS WITH UP TO 2 LRCS PER GROUP.
 - c) THE LRC SHALL REQUIRE NO ADDRESSING AND CONNECT WITH 2-WIRE, STRANDED, NON-POLAR WIRE TO ITS FCU. THE LRC SHALL REQUIRE CROSSOVER WIRING FOR GROUPING TO OTHER FCUs.
 - 3) CENTRAL CONTROLLER:
 - a) THE CENTRAL CONTROLLER SHALL BE CAPABLE OF CONTROLLING A MAXIMUM OF 50 FCUs ACROSS MULTIPLE CUs. THE CENTRAL CONTROLLER SHALL BE POWERED BY A POWER SUPPLY UNIT PROVIDED BY THE VRF SYSTEM MANUFACTURER. THE CENTRAL CONTROLLER SHALL SUPPORT SYSTEM CONFIGURATION, SCHEDULING, STATUS MONITORING, SETBACK SETTING, INTERLOCK CONFIGURATION, AND ALARM REPORTING.
 - b) THE CENTRAL CONTROLLER SHALL HAVE 5 BASIC OPERATING CONTROLS WHICH CAN BE APPLIED TO A FCU, GROUP OF FCUs, OR ALL FCUs. THE BASIC OPERATING CONTROLS SHALL INCLUDE START/STOP, MODE, TEMPERATURE SETPOINT, FAN SPEED, AIRFLOW DIRECTION SETTING, AND SCHEDULING. THE BASIC OPERATIONS SHALL BE AS DETERMINED BY THE CAMPUS EMS AND SENT TO CENTRAL CONTROLLER FOR DEPLOYMENT OF OPERATIONS.
 - c) THE CENTRAL CONTROLLER SHALL BE CAPABLE OF ENABLING OR DISABLING OPERATION OF LRCS.
 - d) THE CENTRAL CONTROLLER SHALL BE EQUIPPED WITH 1 RJ-45 ETHERNET PORT.
 - 4) BACNET INTEGRATION:
 - a) THE VSCN SHALL INTERFACE WITH THE CAMPUS EMS. THE VSCN INTERFACE SHALL BE COMPLIANT WITH BACNET PROTOCOL AND CERTIFIED BY THE BACNET TESTING LABORATORIES. THE BACNET INTERFACE SHALL SUPPORT BACNET BROADCAST MANAGEMENT.

4. EXHAUST FANS

- A. RUN CONDITIONS - INTERLOCKED:
 - 1) EF-1 SHALL BE INTERLOCKED TO RUN WHENEVER VF-1, VF-3, AND VF-5 RUN UNLESS SHUTDOWN ON SAFETIES.
 - 2) EF-2 SHALL BE INTERLOCKED TO RUN WHENEVER VF-2 AND VF-4 RUN UNLESS SHUTDOWN ON SAFETIES.
- B. FAN: THE FAN SHALL HAVE A USER DEFINABLE (ADJ.) MINIMUM RUNTIME.
- C. EXHAUST AIR DAMPER: THE EXHAUST AIR DAMPER SHALL OPEN ANYTIME THE UNIT RUNS AND SHALL CLOSE ANYTIME THE UNIT STOPS. THE EXHAUST AIR DAMPER SHALL CLOSE 30 SEC (ADJ.) AFTER THE FAN STOPS.
- D. DAMPER STATUS: THE FAN SHALL BE ENABLED AFTER THE DAMPER STATUS HAS PROVEN.
- E. FAN STATUS: THE CONTROLLER SHALL MONITOR THE FAN STATUS.
- F. ALARMS SHALL BE PROVIDED AS FOLLOWS:
 - 1) DAMPER FAILURE: COMMANDED OPEN, BUT THE STATUS IS CLOSED.
 - 2) DAMPER IN HAND: COMMANDED CLOSED, BUT THE STATUS IS OPEN.
 - 3) FAN FAILURE: COMMANDED ON, BUT THE STATUS IS OFF.
 - 4) FAN IN HAND: COMMANDED OFF, BUT THE STATUS IS ON.
 - 5) FAN RUNTIME EXCEEDED: FAN STATUS RUNTIME EXCEEDS A USER DEFINABLE LIMIT (ADJ.).

5. FAN COIL UNIT (100% OSA)

- A. RUN CONDITIONS - SCHEDULED: THE UNIT SHALL RUN ACCORDING TO A USER DEFINABLE TIME SCHEDULE TO MATCH BUILDING OPERATION SCHEDULE.
- B. FAN: THE FAN SHALL RUN ANYTIME THE UNIT IS COMMANDED TO RUN, UNLESS SHUTDOWN ON SAFETIES.
- C. TEMPERATURE CONTROL: THE UNIT SHALL MAINTAIN DISCHARGE TEMPERATURE SETPOINT OF 70°F.
- D. HEATING COIL VALVE:
 - 1) THE CONTROLLER SHALL MEASURE THE DISCHARGE TEMPERATURE AND MODULATE THE HEATING COIL VALVE TO MAINTAIN SETPOINT.
 - 2) HEATING SHALL BE ENABLED WHENEVER:
 - a) AND THE DISCHARGE TEMPERATURE IS BELOW SETPOINT.
 - b) AND OUTSIDE AIR TEMPERATURE IS BELOW 60°F.
 - c) AND THE FAN IS ON.
- E. FILTER HOURS: THE CONTROLLER SHALL MONITOR THE FAN RUNTIME.
- F. DISCHARGE AIR TEMPERATURE: THE CONTROLLER SHALL MONITOR THE DISCHARGE AIR TEMPERATURE.
- G. FAN STATUS: THE CONTROLLER SHALL MONITOR THE FAN STATUS.
- H. AIRFLOW: THE CONTROLLER SHALL MONITOR THE AIRFLOW.
- I. ALARMS SHALL BE PROVIDED AS FOLLOWS:
 - 1) FILTER CHANGE REQUIRED: FILTER HAS BEEN IN USE FOR MORE THAN 2200 HRS (ADJ.).
 - 2) HIGH DISCHARGE AIR TEMP: IF THE DISCHARGE AIR TEMPERATURE IS GREATER THAN 120°F (ADJ.).
 - 3) LOW DISCHARGE AIR TEMP: IF THE DISCHARGE AIR TEMPERATURE IS LESS THAN 40°F (ADJ.).
 - 4) FAN FAILURE: COMMANDED ON, BUT THE STATUS IS OFF.
 - 5) FAN IN HAND: COMMANDED OFF, BUT THE STATUS IS ON.
 - 6) FAN RUNTIME EXCEEDED: FAN STATUS RUNTIME EXCEEDS A USER DEFINABLE LIMIT (ADJ.).
 - 7) HW VALVE POSITION FAILURE: VALVE FEEDBACK SIGNAL DOES NOT CORRESPOND TO VALVE POSITION.
 - 8) LOW OUTSIDE AIRFLOW: AIRFLOW IS LESS THAN 15% OF SETPOINT.

LITTLE
DIVERSIFIED ARCHITECTURAL CONSULTING

1300 Dove Street, Suite 400
Newport Beach, CA 92660
T: 949.698.1400 F: 949.698.1433
www.littleonline.com

This drawing and its design shows are the property of Little Diversified Architectural Consulting. The reproduction, copying or other use of this drawing without their written consent is prohibited and any infringement will be subject to legal action.

© Little 2015

**COMPTON
CCD**

CAMPUS PUBLIC SAFETY BUILDING

**1111 EAST ARTESIA BOULEVARD,
COMPTON CALIFORNIA 90221**

IDENTIFICATION STAMP
DIV. OF THE STATE ARCHITECT
OFFICE OF REGULATION SERVICES

FILE NO: 19-C1
AR: 03-117673

AC: [initials] FLS: [initials] [initials]
DATE: DEC. 17, 2017

16516 dHA + CALPEC

180 S. ARROYO PARKWAY
SUITE NO. 100
PASADENA, CA 91105
TEL: (626) 445-8590
FAX: (626) 445-8081

PRINCIPAL IN CHARGE
KEVIN CHEN

PROJECT MANAGER

DRAWN BY
dHA+CALPEC

NO	REASON	DATE



MECHANICAL SEQUENCE OF OPERATION

913-4675-01

11/21/16 **M6.0.3**

GENERAL NOTES

SEISMIC BRACING NOTES

PLUMBING PIPE TYPE LEGEND

PLUMBING SYMBOL LEGEND

- 1. THE LOCATIONS SHOWN OF THE EXISTING UTILITIES ARE APPROXIMATE AND ARE TO IDENTIFY POINTS OF CONNECTIONS FOR NEW UTILITY SERVICES OR FOR COORDINATION OF CLEARANCES BETWEEN EXISTING AND NEW UTILITIES...

- 28. PROVIDE REQUIRED CORROSIVE SOIL PROTECTION FOR UNDER SLAB UTILITIES/PIPING AS WELL AS ON SITE UTILITIES/PIPING PER RECOMMENDATION OF THE GEOTECHNICAL REPORT...

- 1. CONTRACTOR TO PROVIDE SEISMIC ANCHORAGE AND BRACING FOR MECHANICAL EQUIPMENT THAT IS DIRECTLY MOUNTED ON THE FLOOR OR ROOF AND MECHANICAL EQUIPMENT THAT IS SUSPENDED FROM THE FLOOR, WALL OR SUPPORTED BY VIBRATION ISOLATORS...

Table with columns SYMBO, FLUID ABBREV, DESCRIPTION. Lists plumbing pipe types like SOIL OR WASTE PIPING, VENT PIPING, STORM DRAIN PIPING, etc.

PLUMBING ABBREVIATIONS

Table with columns ABBREV, DESCRIPTION, ABBREV, DESCRIPTION. Lists abbreviations like AMP, AV, AD, etc.

Table with columns SYMBO, ABBREV, DESCRIPTION. Lists plumbing symbols like (E), (N), arrow symbols, etc.

PLUMBING NOTATION LEGEND

Table with columns SYMBO, ABBREV, DESCRIPTION. Lists notation symbols like POC, POD, sheet key notes, etc.

PLUMBING DRAWING LIST

Project information block including Little Diversified Architectural Consulting logo, project name (CAMPUS PUBLIC SAFETY BUILDING), location (1111 EAST ARTESIA BOULEVARD, COMPTON CALIFORNIA 90221), identification stamp, and professional seal.

DOMESTIC TANKLESS GAS-FIRED HOT WATER HEATER SCHEDULE

SYMBOL	DESCRIPTION	LOCATION	MANUFACTURER & MODEL NUMBER	STORAGE CAPACITY (GALLONS)	RATE OF RECOVERY @ 60°F	NO. OF CFH	ELECTRICAL REQUIREMENTS			OPERATING WEIGHT (LBS.)	MOUNTING DETAIL	REMARKS
							VOLTS	PHASE	HERTZ			
WH 1	WATER HEATER	CUSTODIAL ROOM #A120	AO SMITH ATI 540H-N	TANKLESS	6.3 (GPM)	199	120	1	60	60	9 P5.01	COMMERCIAL GAS TANKLESS HIGH EFFICIENCY CONDENSING ULTRA-LOW NOx WALL MOUNTED. PROVIDE IN LINE WATER HEATER SHIELD EHS-10, AQASTAT & 3" PVC CONCENTRIC VENT KIT. 9007611005

DOMESTIC HOT WATER CIRCULATING PUMP SCHEDULE

SYMBOL	MANUFACTURER & MODEL NUMBER	LOCATION	SERVICE	TYPE	CAPACITY (GPM)	TOTAL DYNAMIC HEAD (FT)	RPM	ELECTRICAL DATA				OPERATING WEIGHT (LBS.)	REMARKS
								HP	VOLTS	PHASE	HERTZ		
CP 1	GRUNDFOS UPS 15-55 SUC	CUSTODIAL ROOM #A120	WH-1	INLINE	-	-	-	0.12	115	1	60	15	3 SPEED PUMP

THERMOSTATIC MIXING VALVE SCHEDULE

SYMBOL	DESCRIPTION	LOCATION	MANUFACTURER & MODEL NUMBER	CW IN	HW IN	HW/TW OUT	REMARKS
TMV 1	THERMOSTATIC MIXING VALVE	FOR EACH LAVATORY AND SINK	LEONARD 170-LF-BP-BRKT	3/8"	3/8"	3/8"	
TMV 2	THERMOSTATIC MIXING VALVE	CUSTODIAL ROOM #A120	LEONARD XL-32-LF-BDT	3/4"	3/4"	3/4"	SET MIXING VALVE TEMPERATURE AT 105°F MIN. AND 120°F MAX.

EXPANSION TANK SCHEDULE

SYMBOL	DESCRIPTION	LOCATION	MANUFACTURER & MODEL NUMBER	STORAGE CAPACITY (GALLONS)	OPERATING WEIGHT (LBS.)	REMARKS
ET 1	EXPANSION TANK	CUSTODIAL ROOM #A120	"AMTROL" THERM-X-TROL ST-5-C	2.1	40	USE WITH WH-1 ASME RATED FOR 150 PSIG.

EARTHQUAKE VALVE SCHEDULE

SYMBOL	DESCRIPTION	MANUFACTURER & MODEL NUMBER	SIZE	REMARKS
EQV 1	EARTHQUAKE VALVE	KOSO 301-7 SERIES	1"	-

GAS PRESSURE REGULATOR SCHEDULE

SYMBOL	DESCRIPTION	MANUFACTURER & MODEL NUMBER	CFH	SIZE	GAS PRESSURE		SPRING COLOR	VENT	SPRING NUMBER	REMARKS
					IN	OUT				
GPR 1	GAS PRESSURE REGULATOR	SENSUS 143-80-2	199	1"	2 P.S.I.	8" WATER COLUM	GREEN	3/8"	143-82-201-17	

AIR COMPRESSOR SCHEDULE

SYMBOL	DESCRIPTION	MANUFACTURER & MODEL NUMBER	LOCATION AND DRAWING REFERENCE	-	ELECTRICAL DATA				OPERATING WEIGHT (LBS.)	MOUNTING DETAIL	REMARKS
					HP	VOLTS	PHASE	HERTZ			
CA 1	AIR COMPRESSOR WITH HOSE REEL	AIR MACHINE 8670-2FBGA WITH 6026	PARKING LOT	-	3/4	120	1	60	125	10 P5.01	JE ADAMS AIR MACHIN 3/4HP OILESS AIR COMPRESSOR CUT RESISTANT 25x1/4" AIR HOUSE W/INFLATOR GUGE PUSH BUTTON OPERATION COMPLETE WITH JE ADAMES RETRACTABLE HOSE BASE STAINLESS STEEL

PLUMBING FIXTURE SCHEDULE

SYMBOL	FIXTURE	BRANCH CONNECTION					CARRIER	REMARKS
		TRAP	WASTE	VENT	HW	CW		
WC 1	WATER CLOSET WALL HUNG	INTEGRAL	4"	2	-	1-1/2"	JR SMITH 0400 OR 0200 SERIES	"AMERICAN STANDARD" APFALL FLOWISE MODEL 3351.001 VITREOUS CHINA, WHITE, ELONGATED BOWL, SIPHON JET, COMPLETE WITH SLOAN "ROYAL" 111-1.28 SOLAR MANUAL FLUSHOMETER, 1.28 GALLONS PER FLUSH, "BEMIS" 1955C ELONGATED OPEN FRONT SEAT LESS COVER. MOUNT PER A.D.A. REQ'S.
WC 2	WATER CLOSET WALL HUNG - ADA	INTEGRAL	4"	2	-	1-1/2"	JR SMITH 0400 SERIES	"ACORN" 2105-W-1-CN 1.28-FWH-ADA SIPHON JET 1.28 GPF COMPLETE WITH HYDRAULIC FLUSH VALVE WITH HYDRAULIC PUSHBUTTON P/N 3918762. MOUNT PER A.D.A. REQ'S.
L 1	LAVATORY COUNTER MOUNTED	1-1/2"	2"	-	3/4"	3/4"	-	AMERICAN STANDARD DROP IN SELF RIMMING LAVATORY MODEL 0476.028 WITH SLOAN EBF-650-BDT FAUCET AND BELOW DECK THERMOSTATIC MIXING VALVE. FAUCET SHALL BE ELECTRONIC FAUCET, FLOW RATE 0.5-GPM FOR A 15-SEC. CYCLE. 4 CELL ALKALINE BATTERIES. PROVIDE "TRUEBRO" INSULATING KIT FOR WASTE & HW SUPPLY TRIMS & SUPPLIES (SELF CLOSING).
L 2	LAVATORY WALL HUNG	1-1/2"	2"	-	3/4"	3/4"	-	"ACORN" 1652-1-BP-03-M 18"LAVATORY WITH OVAL BOWL. MOUNT PER A.D.A. REQ'S.
SK 1	1-COMPARTMENT SINK COUNTERTOP MOUNTED	1-1/2" CP 17 GA. CAST BRASS	2"	1-1/2"	3/4"	3/4"	-	"JUST" #SL-ADA-1921-A-GR, 19"x21"x6.5" DEEP. PROVIDE #J-ADA-35 BASKET STRAINER CHICAGO #201-AE35ABCP LEVER FAUCET, 1.5 GPM. RIGID RISER, ESCUTCHEON, ALL IN CHROME, OR ACCEPTED EQUAL. PROVIDE "TRUEBRO" W & HW INSULATING KIT.
SS 1	SERVICE SINK	3"	3"	2"	3/4"	3/4"	-	KOHLER "WHITBY" #K-6710 OR ACCEPTED EQUAL, SINK: 28"x28", FLOOR MOUNTED, ENAMELED CAST-IRON WITH VINYL RIM COVER K-8940 AND FAUCET WITH 2 3/8" HANDLES, STOPS, VACUUM BREAKER, BUCKET HOOK AND SPOUT BRACE TO WALL. FAUCET SHALL BE "CHICAGO" 897-RCF.
DF 1	DRINKING FOUNTAIN ACCESSIBLE	1-1/2" CP 17 GA. CAST BRASS	2"	1-1/2"	-	3/4"	-	"ELKAY" #LZWS-EDFBM117K, DUAL LEVEL STAINLESS STEEL HI-LO WITH EZH20 BOTTLE FILLING STATION, INDOOR, WITH ADDITIONAL REPLACEMENT FILTER #51300C-3 PACK. 100% LEAD FREE WATERWAYS.
HB 1	HOSE BIBB	-	-	-	-	3/4"	-	"ACORN" 8121-SSLF STAINLESS STEEL LEAD FREE WITH VACUUM BREAKER.
HB 2	HOSE BIBB	-	-	-	-	3/4"	-	"ACORN" 8151-SSLF STAINLESS STEEL RECESSED HOSE BOX WITH WALL FLANGE LEAD FREE WITH VACUUM BREAKER.
TP 1	TRAP PRIMER (ELECTRONIC)	-	-	-	-	3/4" TP	-	TRAP PRIMER SHALL BE PPP INC. "PRIME-PRIME" #MP-500-115V COMPLETE WITH DISTRIBUTION #DU-X UNIT AS REQUIRED OR APPROVED EQUAL BY MIFAB OR SIOUX CHIEF. PROVIDE ACCESS PANEL AND SHUT-OFF VALVE FOR EACH ASSEMBLY.
TP 2	TRAP PRIMER	-	-	-	-	3/4" TP	-	TRAP PRIMER SHALL BE PPP INC. "PRIME-PRIME" #PR-500 COMPLETE WITH DISTRIBUTION #DU-X UNIT AS REQUIRED OR APPROVED EQUAL BY MIFAB OR SIOUX CHIEF. PROVIDE ACCESS PANEL AND SHUT-OFF VALVE FOR EACH ASSEMBLY.
FD 1	FLOOR DRAIN	2"	2"	1-1/2"	-	1/2" TP	-	"J.R. SMITH" FIG. 2005Y(9)-U-P050-BHP-PB CAST IRON BODY COMPLETE WITH FLASHING COLLAR, NO HUB CONNECTION, SQUARE TOP VANDAL PROOF SCREWS, TRAP PRIMER CONNECTION, ADJUSTABLE POLISH BRONZE STRAINER HEAD WITH HEEL PROOF GRATE OR APPROVED EQUAL. FLOOR DRAIN 1/2" MAX OPENING
SH 1	SHOWER	-	-	-	3/4"	3/4"	-	"LEONARD" THERMOSTATIC/PRESSURE SHOWERMASTER MODEL 7600-VP-515P-D-2L-H-06-1.5-D. VANDAL RESISTANT SCREW, 1.5 GPM HAND SPRAY, STAINLESS STEEL FLEX HOSE, SLIDE BAR, DOUBLE CHECK VALVE BACKFLOW PREVENTER, LEVER HANDLE DIVERTERS AND 1.5 GPM FIXED SHOWER HEAD OR APPROVED EQUAL.
SHD 1	SHOWER DRAIN	2"	2"	1-1/2"	-	-	-	"J.R. SMITH" FIG. 2005YA-PB CAST IRON BODY COMPLETE WITH FLASHING COLLAR, NO HUB CONNECTION, ADJUSTABLE POLISHED BRONZE STRAINER HEAD OR APPROVED EQUAL. DRAIN OPENING 1/4" MAX.

NOTE: ALL PLUMBING FIXTURES APPLIANCES AND DEVICES, EQUIPMENT SHALL BE LISTED OR APPROVED TYPE. THEY MUST ALSO MEET LEAD FREE AND L.A. CITY PLUMBING CODE 2014, SECTION 402. ALL FAUCETS IN PUBLIC RESTROOMS SHALL BE SELF CLOSING OR SELF CLOSING METERING FAUCETS PER L.A. PLUMBING CODE 2014, SECTION 402.

PLUMBING WATER SUPPLY FIXTURE UNITS CALCULATION

PLUMBING DRAINAGE FIXTURE UNITS CALCULATION

TYPE	NUMBER OF FIXTURE	FIXTURE UNIT	TOTAL FIXTURE UNITS	TYPE	NUMBER OF QUALITIES	FIXTURE UNIT	DIFFERENCE FIXTURE UNITS
WATER CLOSET	3	5	15	WATER CLOSET	3	4	12
LAVATORY	3	1	3	LAVATORY	3	1	3
SHOWER HEAD	2	2	4	SHOWER DRAIN	2	2	4
SINK	1	2	2	SINK	1	2	2
SERVICE SINK	1	3	3	SERVICE SINK	1	3	3
DRINKING FOUNTAIN	1	1	1	FLOOR DRAIN	6	2	12
HOSE BIBB	7	2.5/1	8.5	DRINKING FOUNTAIN	1	1	1
OVERALL FIXTURE UNIT VALUE			34.5	OVERALL FIXTURE UNIT VALUE			37

LITTLE
DIVERSIFIED ARCHITECTURAL CONSULTING

1300 Dove Street, Suite 100
Newport Beach, CA 92660
T: 949.698.1400 F: 949.698.1433
www.littleonline.com

This drawing and the design shown are the property of Little Diversified Architectural Consulting. The reproduction, copying or other use of this drawing without their written consent is prohibited and any infringement will be subject to legal action.

© Little 2015

**COMPTON
CCD**

CAMPUS PUBLIC SAFETY BUILDING

1111 EAST ARTESIA BOULEVARD,
COMPTON CALIFORNIA 90221

IDENTIFICATION STAMP
DIV. OF THE STATE ARCHITECT
OFFICE OF REGULATION SERVICES

FILE NO: 15-C1
AR: 03-117673

AC: [Signature] PLS: [Signature] SS: [Signature] P: [Signature]
DATE: DEC 17 2017

16516 dHA + CALPEC

150 S. ARROYO PARKWAY
SUITE NO. 100
PASADENA, CA 91105
TEL: (626) 445-8580
FAX: (626) 445-8081

PRINCIPAL IN CHARGE
KEVIN CHEN

PROJECT MANAGER

DRAWN BY
dHA+CALPEC

NO REASON DATE



PLUMBING SCHEDULES

913-4675-01

11/21/16 P0.0.2

**COMPTON
CCD**

CAMPUS PUBLIC SAFETY BUILDING
**1111 EAST ARTESIA BOULEVARD,
COMPTON CALIFORNIA 90221**

IDENTIFICATION STAMP
DIV. OF THE STATE ARCHITECT
OFFICE OF REGULATION SERVICES
FILE NO: 19-C1
AR: 03-117673
AC: [initials] FS: [initials] SS: [initials]
DATE: Dec. 1, 2017

16516 dHA + CALPEC
150 S. ARROYO PARKWAY
SUITE NO. 100
PASADENA, CA. 91105
TEL: (626) 445-8580
FAX: (626) 445-8081

PRINCIPAL IN CHARGE
KEVIN CHEN
PROJECT MANAGER
DRAWN BY
dHA+CALPEC

NO.	REASON	DATE



PLUMBING - SITE PLAN

913-4675-01

11/21/16 P1.1.1

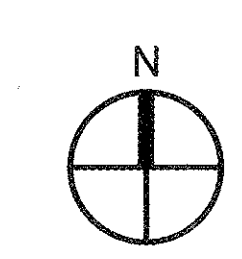
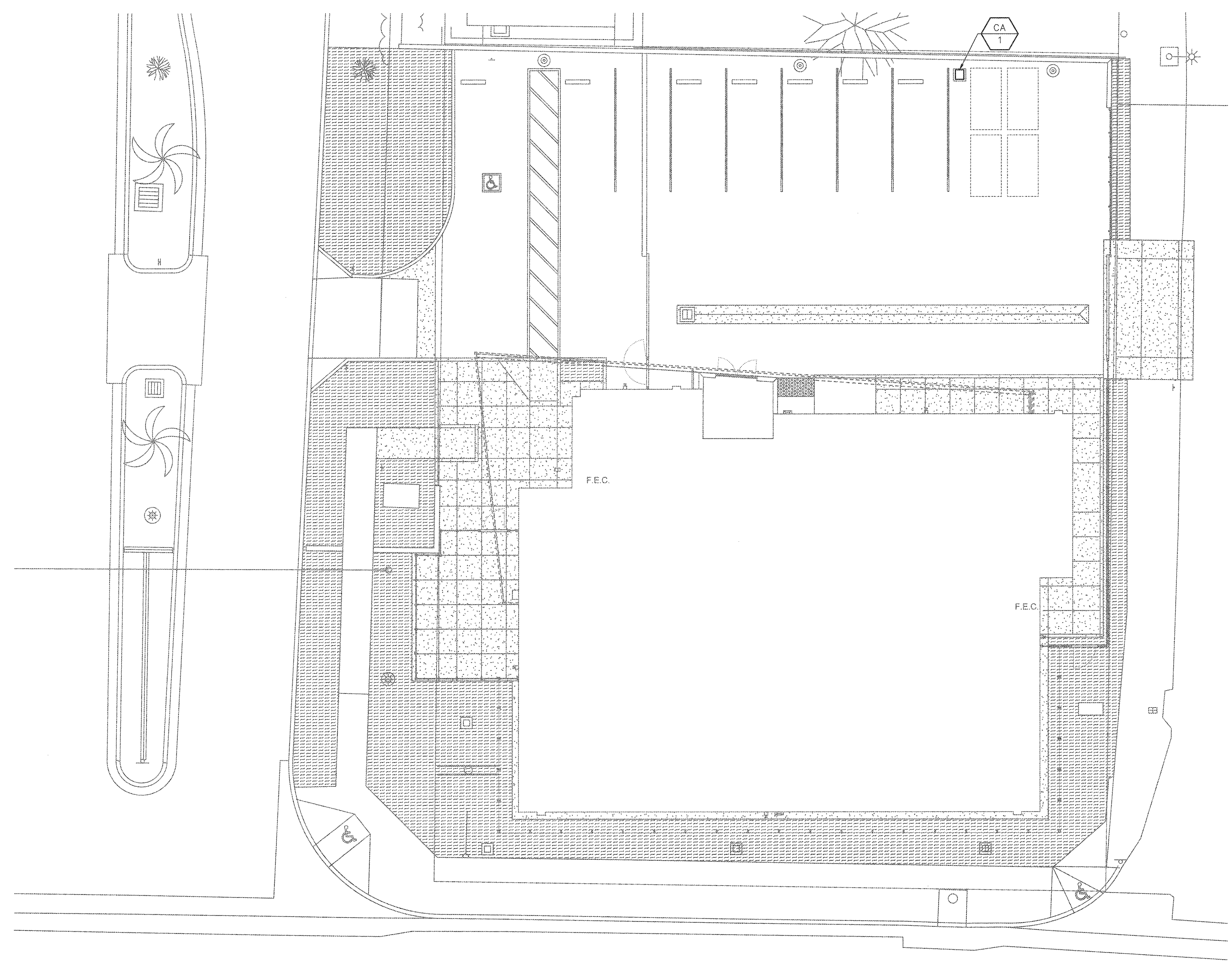

1 PLUMBING SITE PLAN
1/8" = 1'-0"

REFERENCE NOTES

- 1 1-1/2" CW, 4" S DN & 2" V.
- 2 3/4" CW, 2" W DN & 1-1/2" V.
- 3 2" W DN & 1-1/2" V.
- 4 3/4" CW DN IN WALL.
- 5 3/4" CW DN, 3/4" HW DN, 2" W DN & 1-1/2" V.
- 6 EXTEND 3/4" CW & STUB-OUT W/SOV FOR THE REF.
- 7 3/4" CW, 3/4" HW DN, 3" W DN & 2" V.
- 8 3/4" CW & 3/4" HW DN.
- 9 PROVIDE GAS COCK & FLEXIBLE CONNECTION.
- 10 1" CW DN W/SOV.
- 11 PROVIDE PIPE SLEEVE.

LITTLE
DIVERSIFIED ARCHITECTURAL CONSULTING

1300 Dove Street, Suite 100
Newport Beach, CA 92660
T: 949.698.1400 F: 949.698.1433

www.littleonline.com
This drawing and the design shown are the property of Little Diversified Architectural Consulting. The reproduction, copying or other use of this drawing without their written consent is prohibited and any infringement will be subject to legal action.
© Little 2015

COMPTON
CCD

CAMPUS PUBLIC SAFETY BUILDING

1111 EAST ARTESIA BOULEVARD,
COMPTON CALIFORNIA 90221

IDENTIFICATION STAMP
DIV. OF THE STATE ARCHITECT
OFFICE OF REGULATION SERVICES
FILE NO: 19-C1
AR: 03-117673
DATE: OCT. 1, 2017

16516 dHA + CALPEC
150 S. ARROYO PARKWAY
SUITE NO. 100
PASADENA, CA 91105
TEL: (626) 445-8580
FAX: (626) 445-8081

PRINCIPAL IN CHARGE
KEVIN CHEN
PROJECT MANAGER

DRAWN BY
dHA+CALPEC

NO REASON DATE



PLUMBING - FLOOR PLAN

913-4675-01

11/21/16 P2.1.1

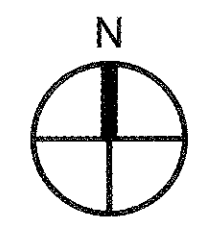
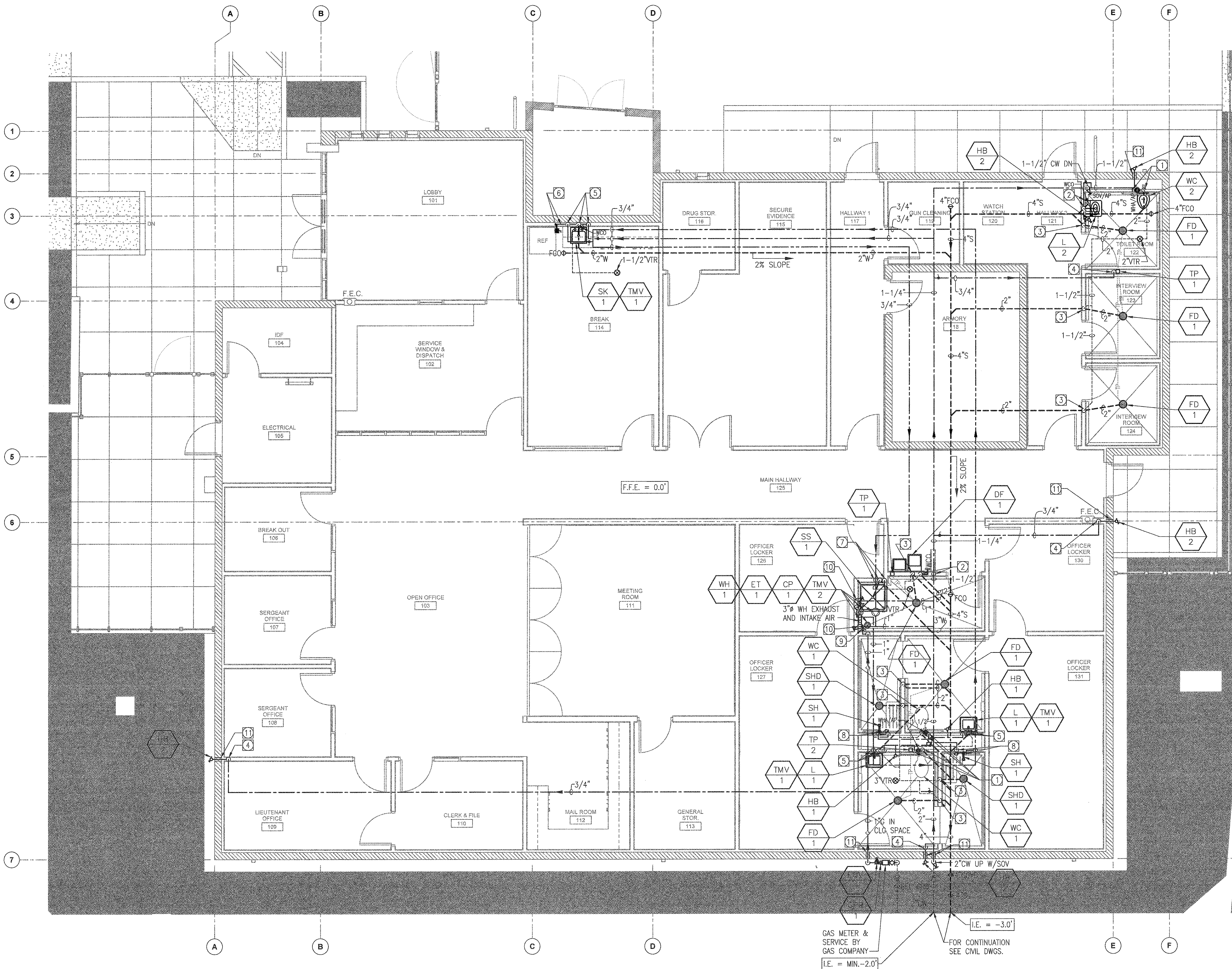

1 PLUMBING FLOOR PLAN
1/4" = 1'-0"

IDENTIFICATION STAMP
DIV. OF THE STATE ARCHITECT
OFFICE OF REGULATION SERVICES

FILE NO: 19-C1
AR: 03-117673

AC: FLS: SS:
DATE: DEC 17 2017

16516 dHA + CALPEC

150 S. ARROYO PARKWAY
SUITE NO. 100
PASADENA, CA. 91105
TEL: (626) 445-8580
FAX: (626) 445-8081

PRINCIPAL IN CHARGE
KEVIN CHEN

PROJECT MANAGER

DRAWN BY
dHA+CALPEC

NO	REASON	DATE



PLUMBING - ROOF PLAN

913-4675-01

11/21/16 | P2.2.1

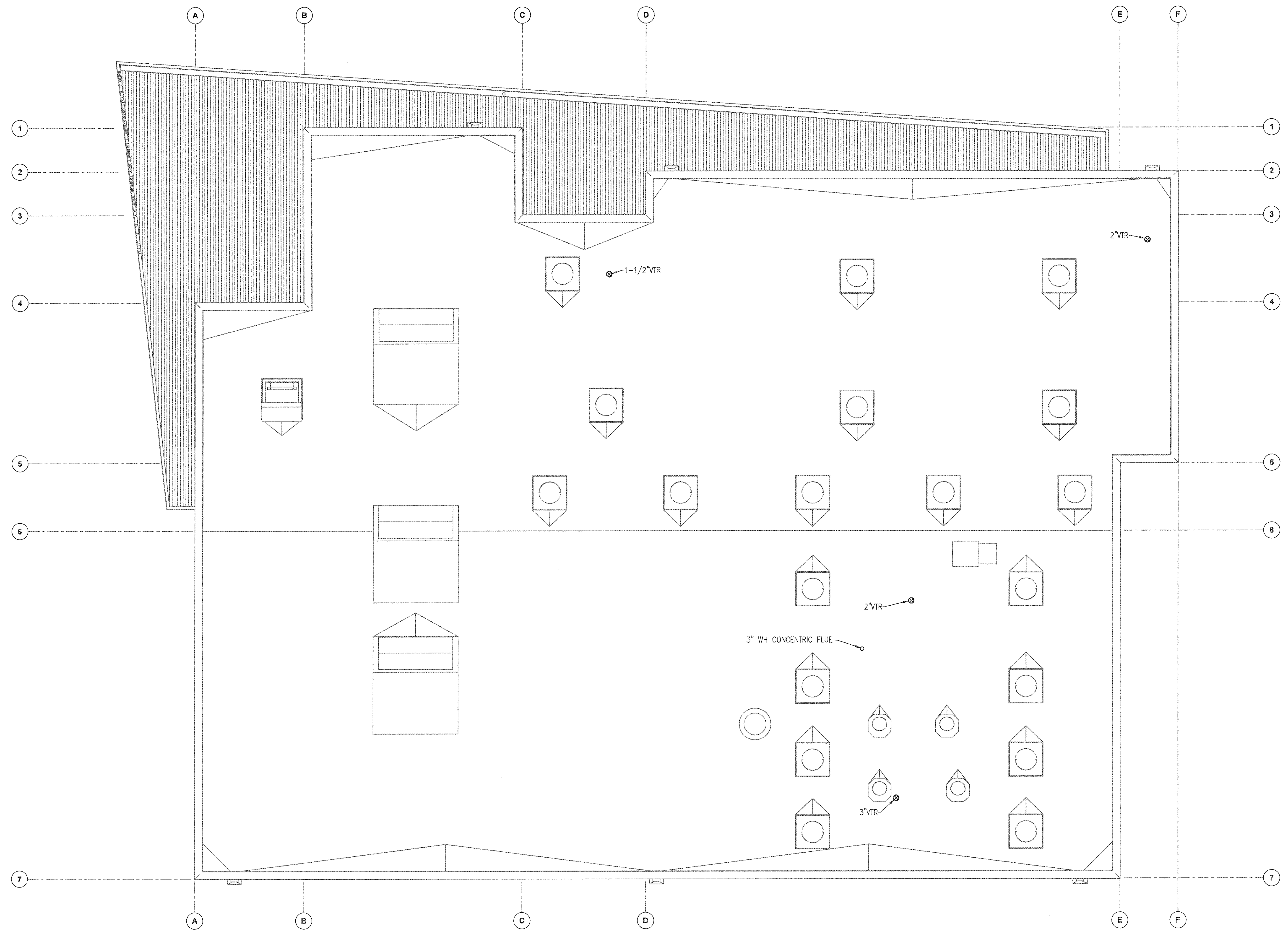

1 PLUMBING ROOF PLAN
1/4" = 1'-0"

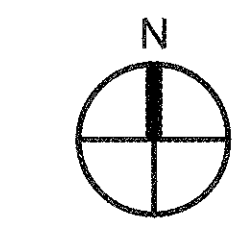

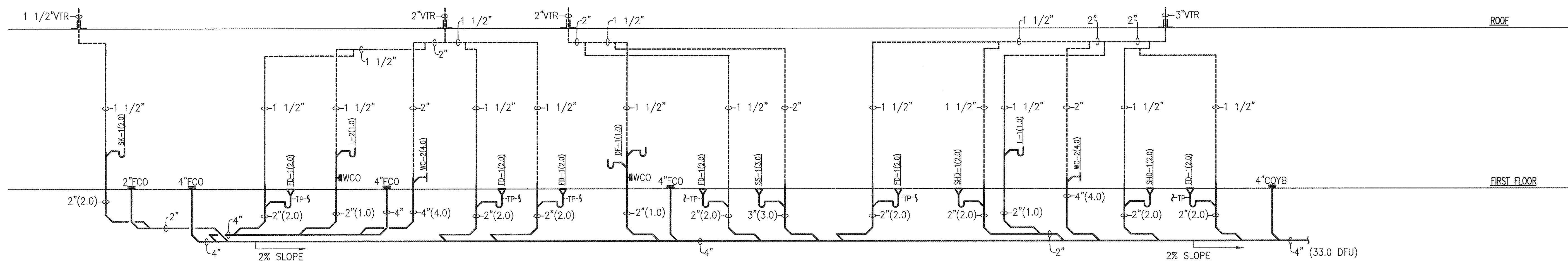

SANITARY WASTE & VENT RISER DIAGRAM

N.T.S. **1**

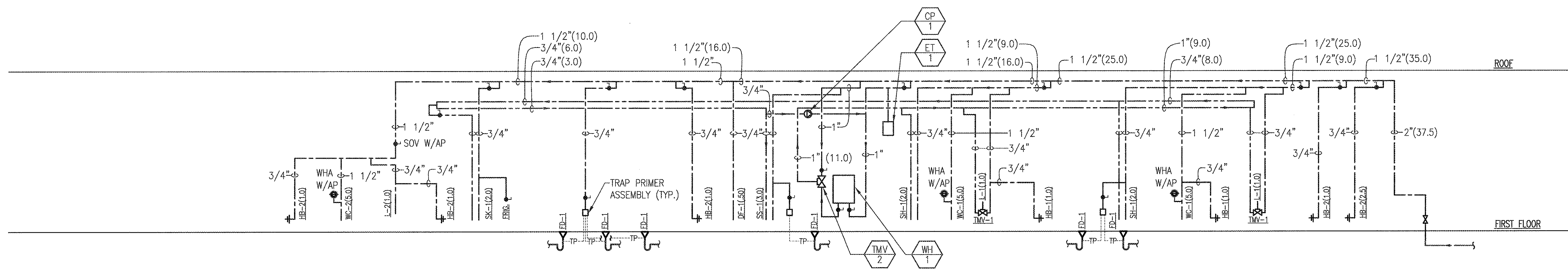

- NOTES:**
- NUMBERS IN () PARENTHESES INDICATES COLD WATER & HOT WATER FIXTURE UNITS.
 - REFER TO PLUMBING FIXTURE SCHEDULE ON DRAWING P0.0.2 FOR BRANCH CONNECTIONS FOR CW & HW SIZES TO EACH FIXTURE.
 - FIXTURE UNITS INDICATED ARE FOR PUBLIC USE, TABLE A-2, 2013 CALIFORNIA PLUMBING CODE.

**POTABLE WATER
CW PIPE SIZING CHART**

TYPE "L" COPPER PIPE 12.4 PSI PER 100 FT. MAX. VEL. @ 8 FPS	MAXIMUM GPM/FU ALLOWABLE			TYPE "L" COPPER PIPE 12.4 PSI PER 100 FT. MAX. VEL. @ 8 FPS	MAXIMUM GPM/FU ALLOWABLE		
	SIZE	GPM	FLUSH TANK FU		SIZE	GPM	FLUSH TANK FU
1/2"	3	3	0	2"	77	260	136
3/4"	8	11	0	2-1/2"	117	474	358
1"	16	23	0	3"	170	747	699
1-1/4"	30	54	13	-	-	-	-
1-1/2"	44	104	35	-	-	-	-

**POTABLE WATER
HW PIPE SIZING CHART**

TYPE "L" COPPER PIPE 12.4 PSI PER 100 FT. MAX. VEL. @ 5 FPS	MAXIMUM GPM/FU ALLOWABLE			TYPE "L" COPPER PIPE 12.4 PSI PER 100 FT. MAX. VEL. @ 5 FPS	MAXIMUM GPM/FU ALLOWABLE		
	SIZE	GPM	FLUSH TANK FU		SIZE	GPM	FLUSH TANK FU
1/2"	3	3	0	2"	48	120	0
3/4"	8	9	0	2-1/2"	74	246	0
1"	12	17	0	3"	105	412	0
1-1/4"	19	29	0	-	-	-	-
1-1/2"	27	48	0	-	-	-	-

DOMESTIC WATER RISER DIAGRAM

N.T.S. **2**

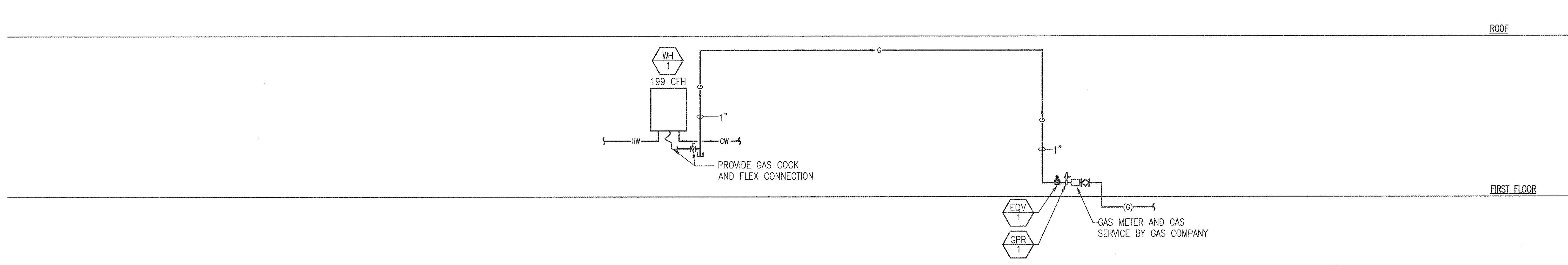

GAS PIPE SIZING SCHEDULE

PIPE SIZE	1/2"	3/4"	1"	1-1/4"	1-1/2"	2"	2-1/2"	3"	4"
CFH	65	137	237	528	791	1520	2,430	4,290	8,760

GAS DEVELOPED LENGTH - 60± FEET
INLET PRESSURE: LESS THAN 2 PSI
PRESSURE DROP: 0.5 IN. W.C.
SPECIFIC GRAVITY: 0.60
GAS LOAD: 199 CFH
PIPE SIZE: 1" GAS

GAS RISER DIAGRAM

N.T.S. **3**

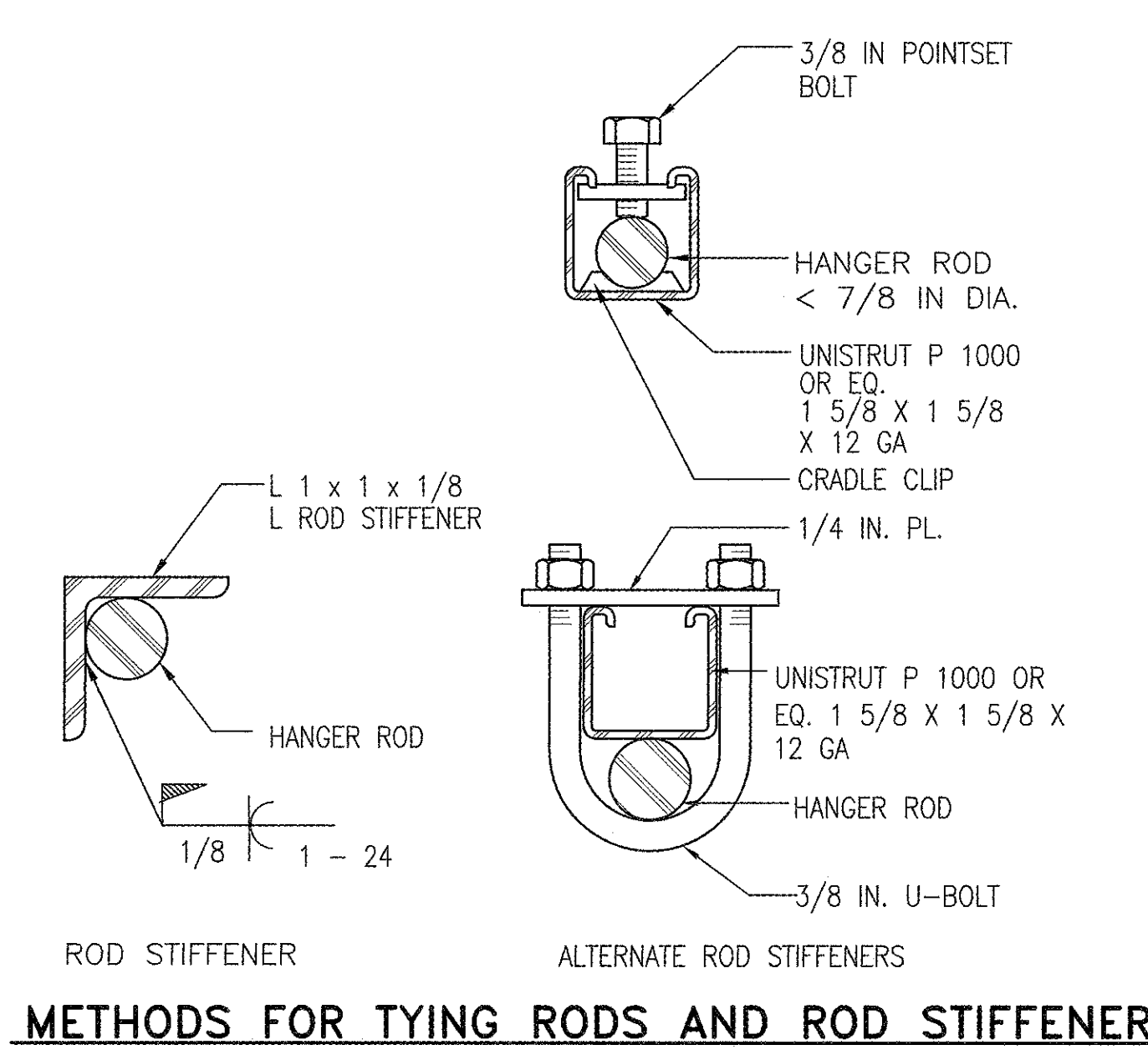

METHODS FOR TYING RODS AND ROD STIFFENERS.

- NOTES:
 1. COORDINATE PIPE SUPPORT SYSTEM WITH STRUCTURAL.
 2. SEE SEISMIC RESTRAINT MANUAL GUIDELINES AS INDICATED ON MO.1 SEISMIC BRACING NOTES FOR MECHANICAL SYSTEMS FOR OTHER HANGER ROD AND BRACING INFORMATION.

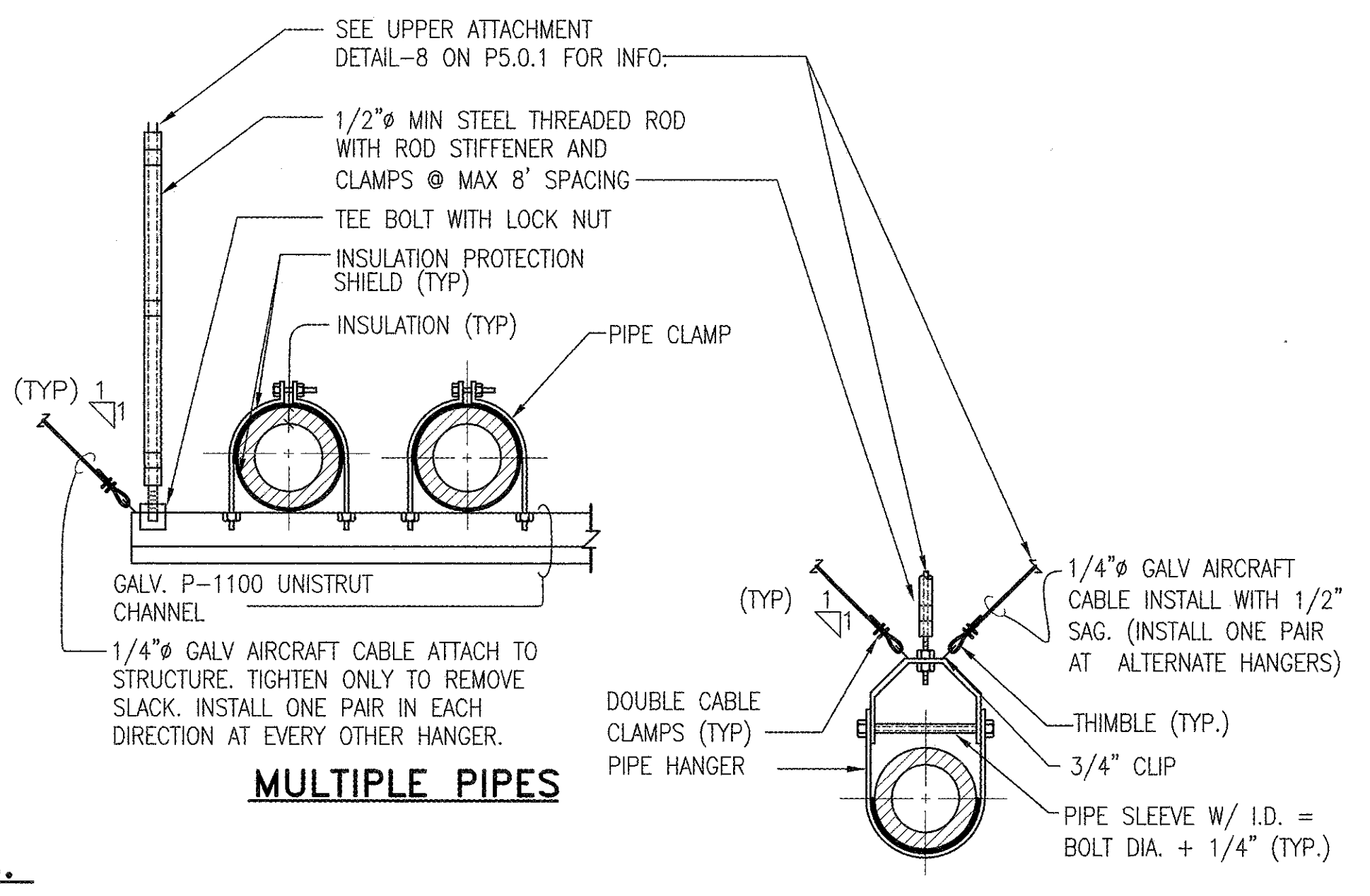

MULTIPLE PIPES

SINGLE PIPE

(300 LBS MAX. TOTAL WEIGHT)

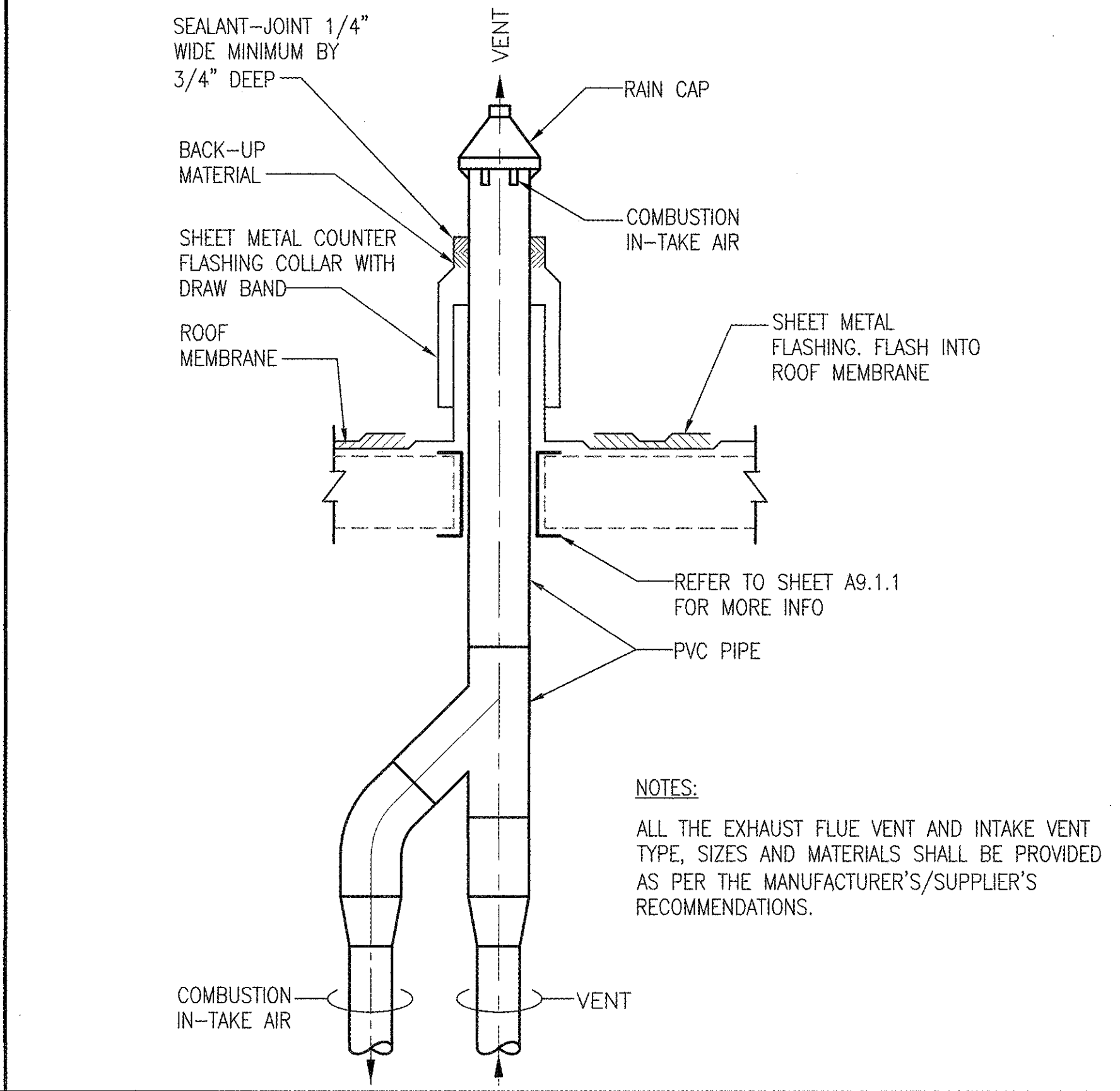

- NOTES:
 ALL THE EXHAUST FLUE VENT AND INTAKE VENT TYPE, SIZES AND MATERIALS SHALL BE PROVIDED AS PER THE MANUFACTURER'S/SUPPLIER'S RECOMMENDATIONS.

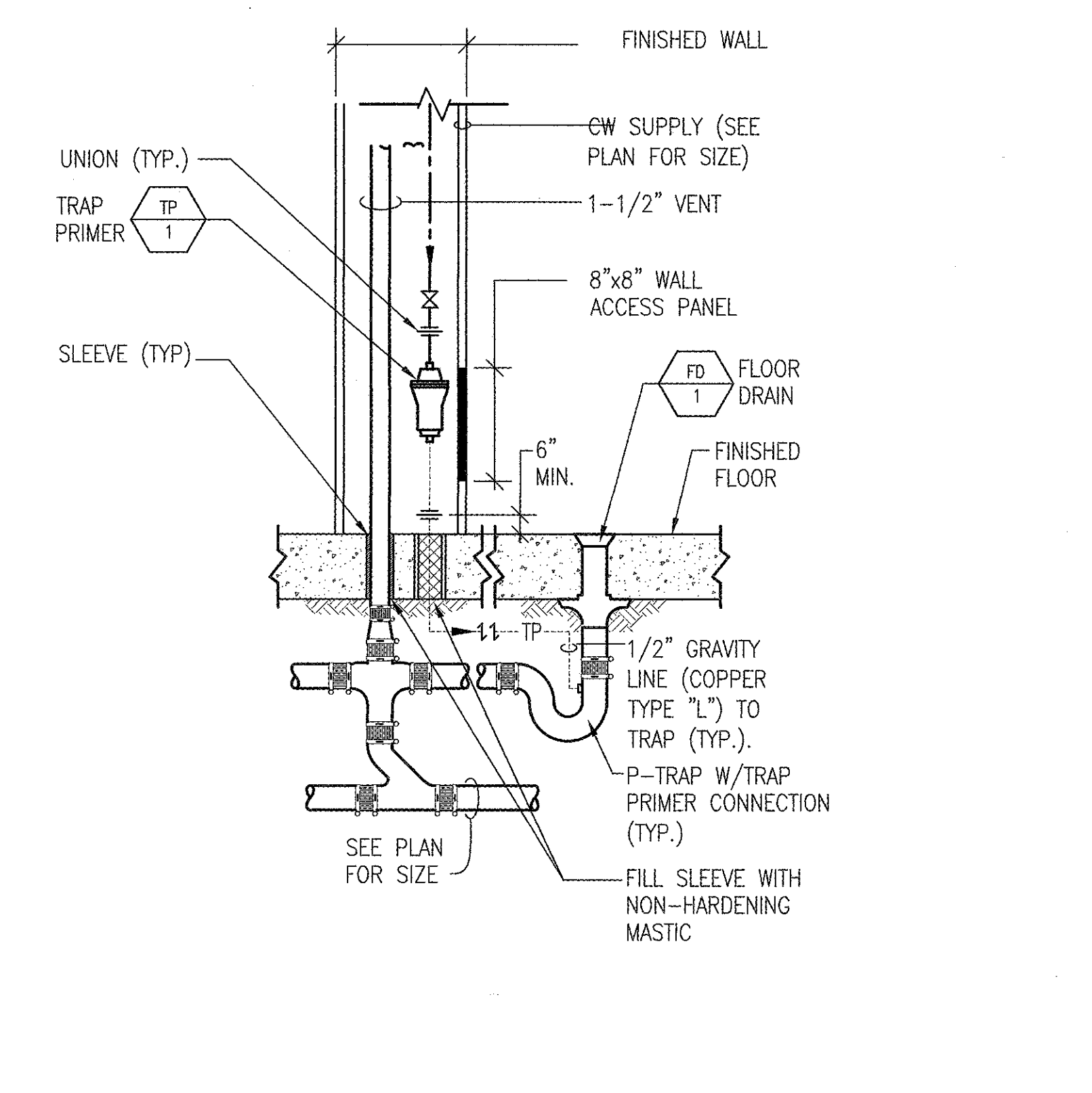

TRAP PRIMER ASSEMBLY

PIPE SUPPORT ABOVE CEILING

N.T.S. 7

PVC SEALED DIRECT VENT W/CONCENTRIC VENT VERTICAL TERMINATION

N.T.S. 4

N.T.S. 1

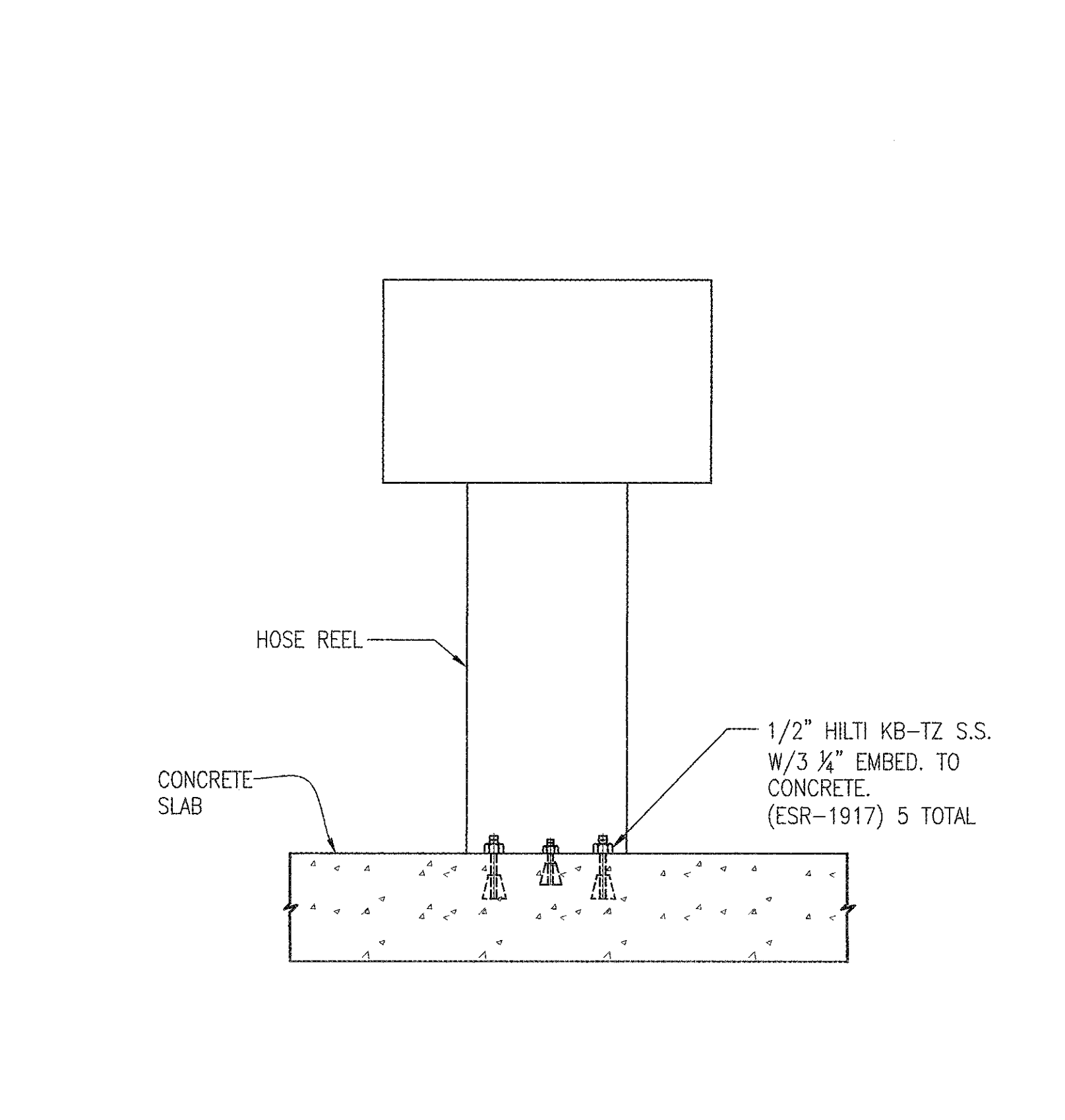

AIR COMPRESSOR

N.T.S. 10

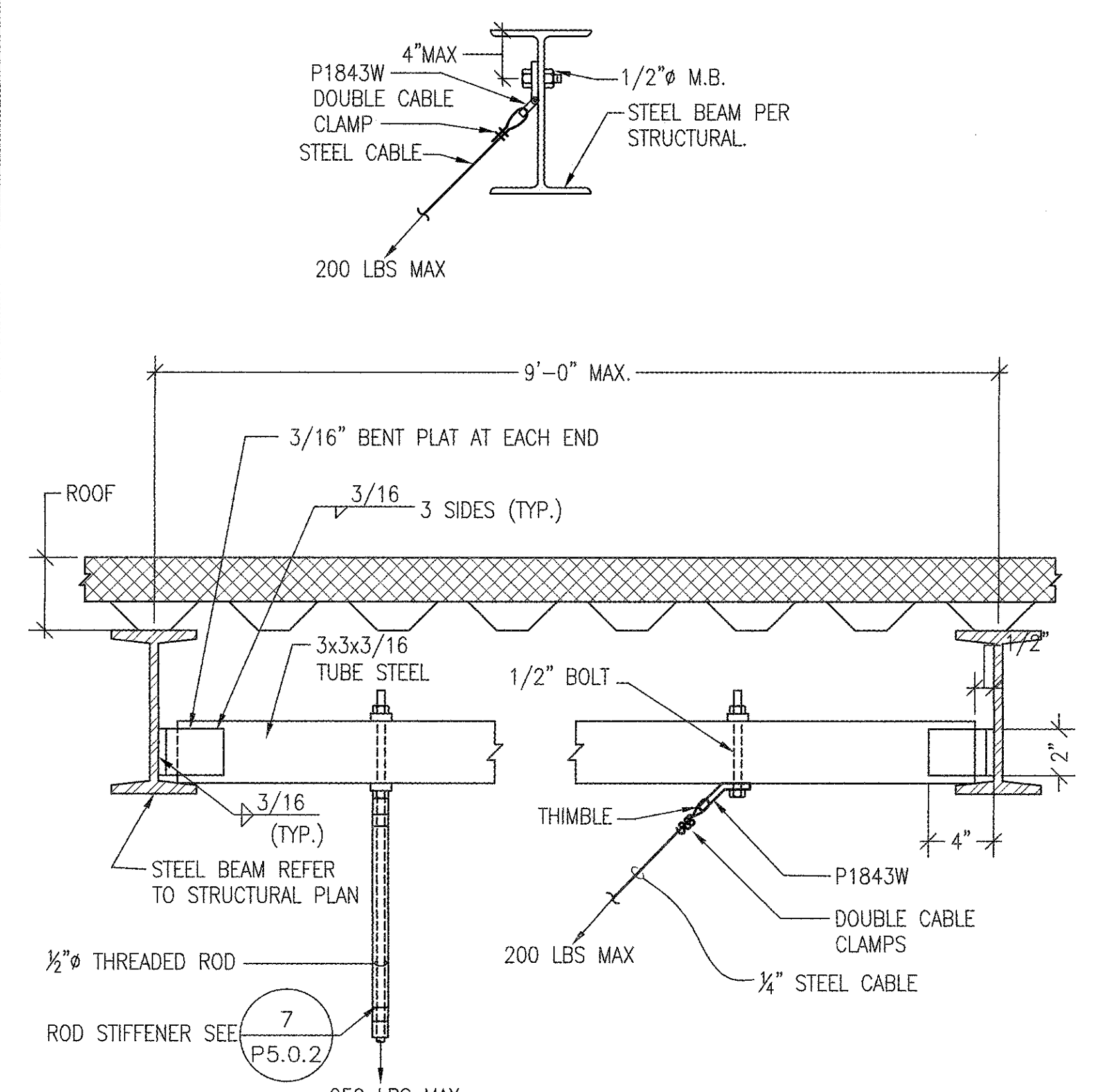

PIPING HANGER UPPER ATTACHMENTS

N.T.S. 8

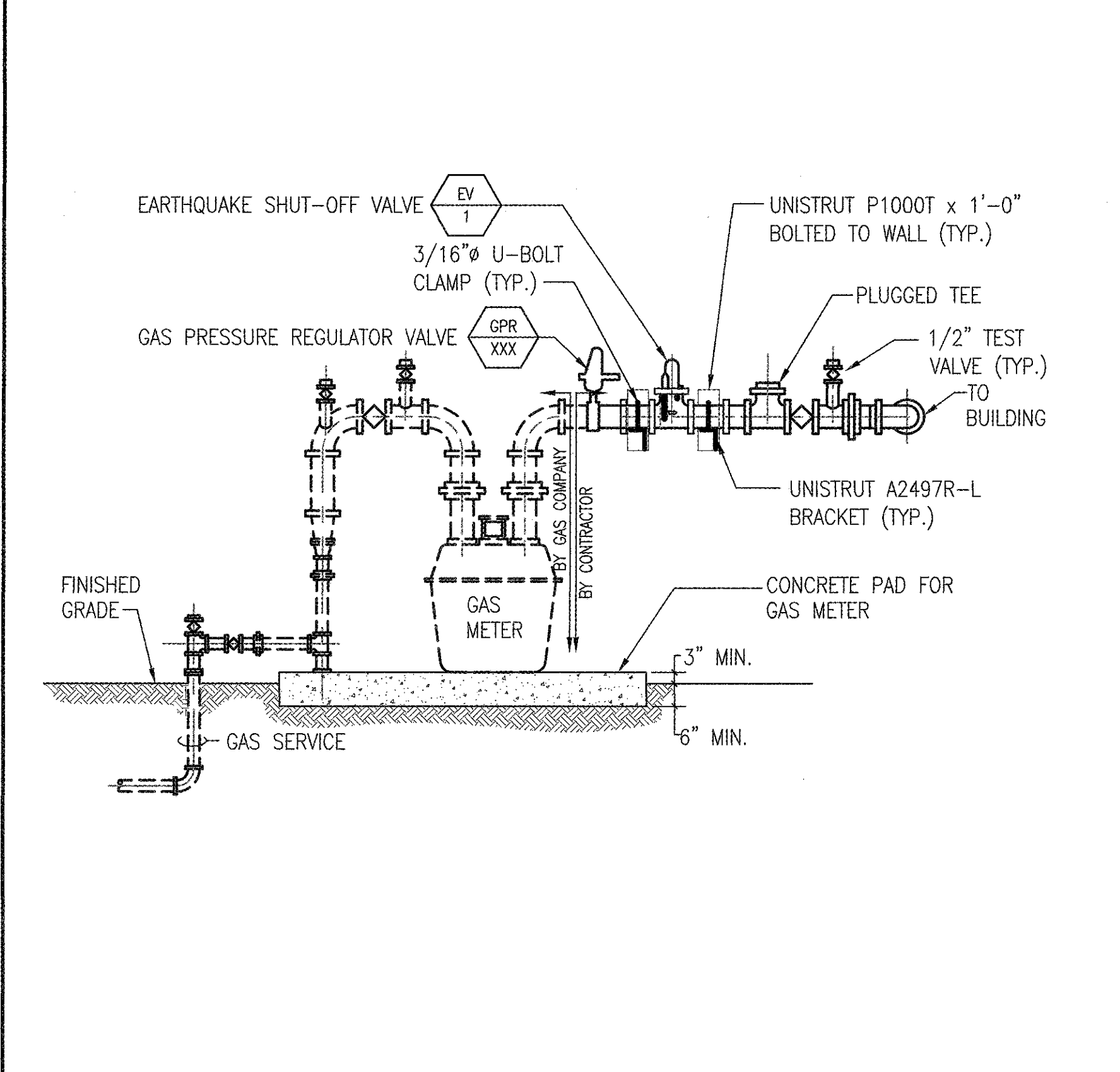

EARTHQUAKE VALVE

N.T.S. 5

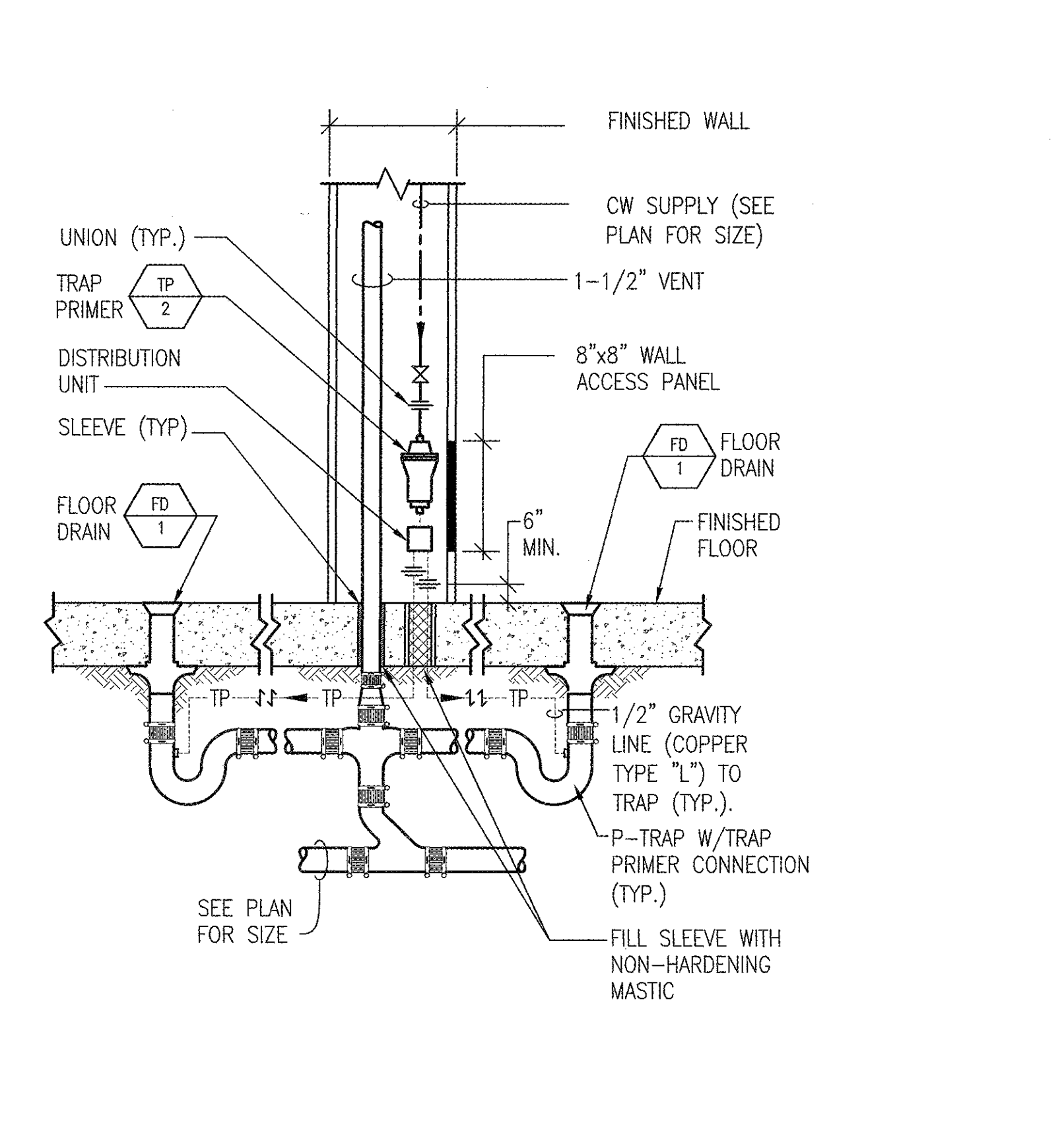

TRAP PRIMER ASSEMBLY

N.T.S. 2

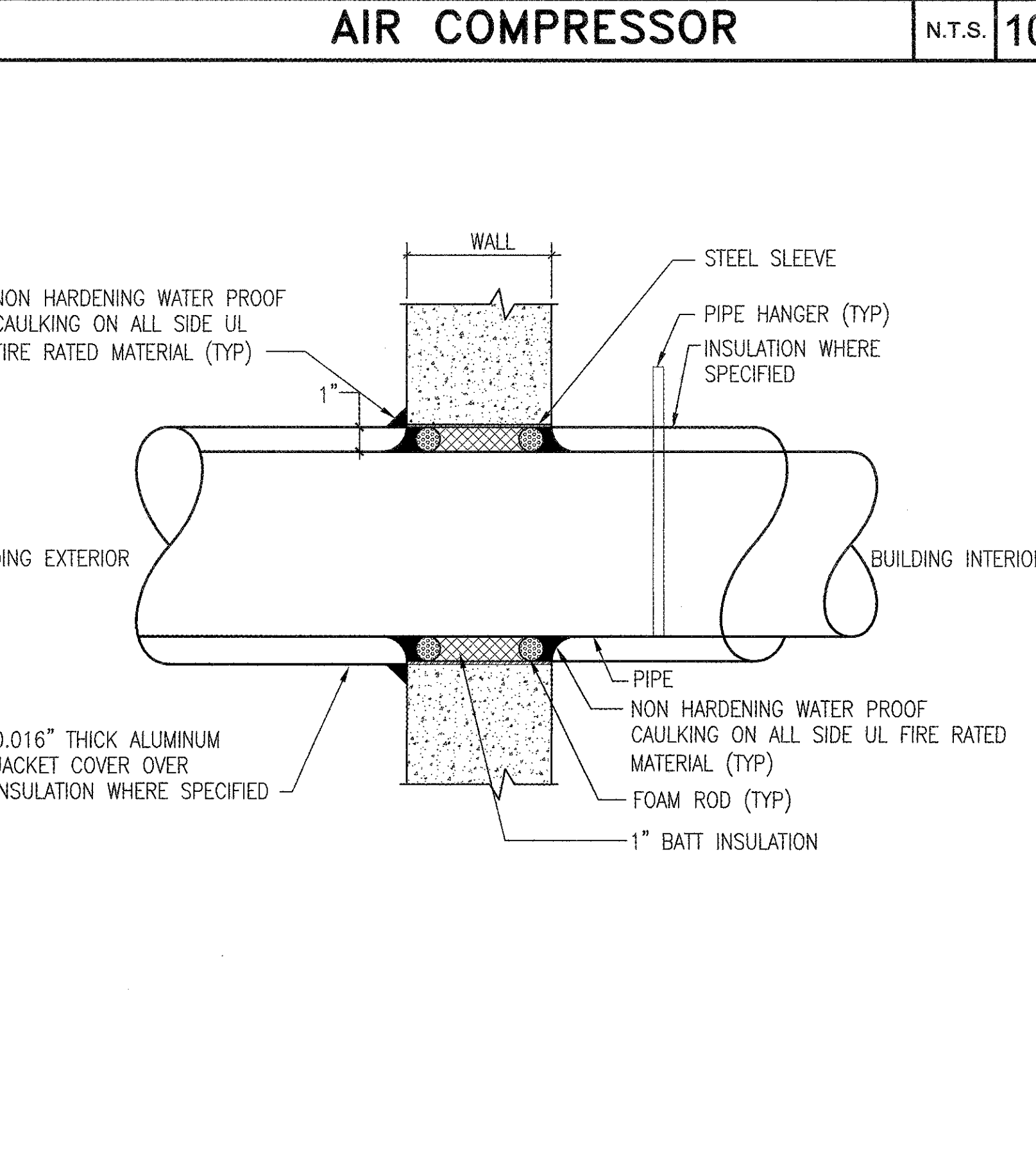

PIPE PENETRATION THRU EXTERIOR WALL

N.T.S. 11

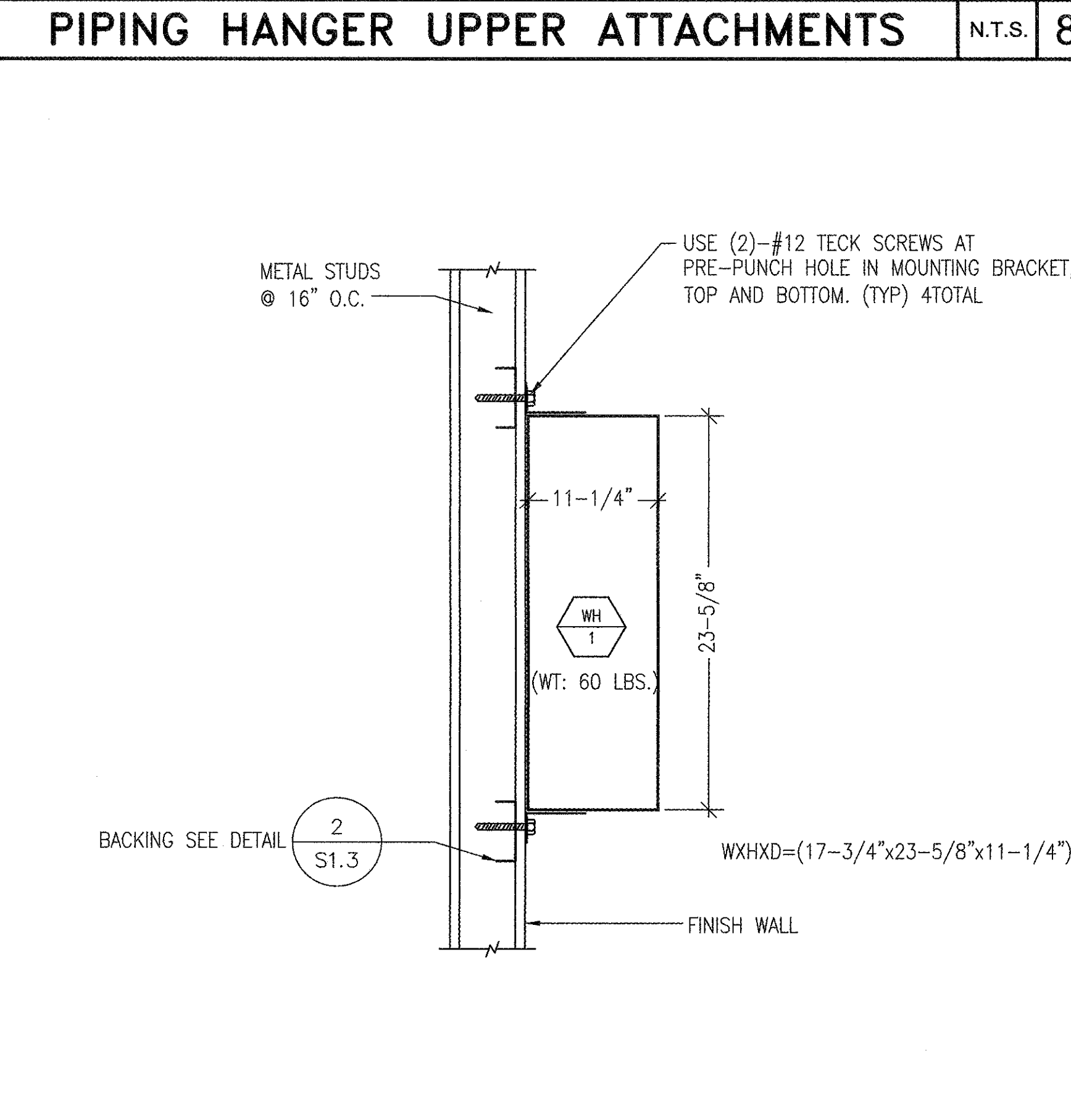

SECURING TO WALL OF TANKLESS HOT WATER HEATER

N.T.S. 9

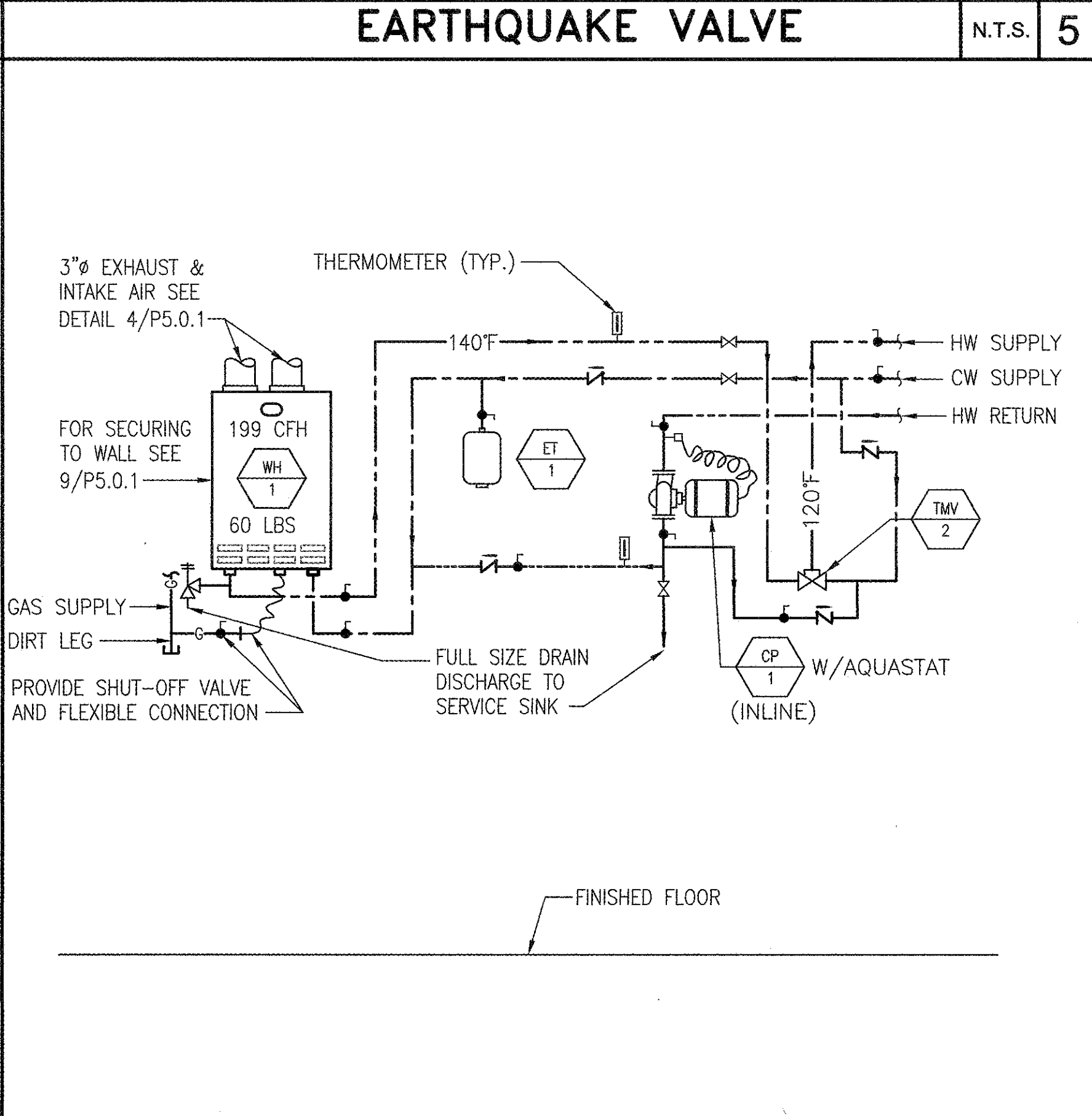

GAS FIRED WATER HEATER

N.T.S. 6

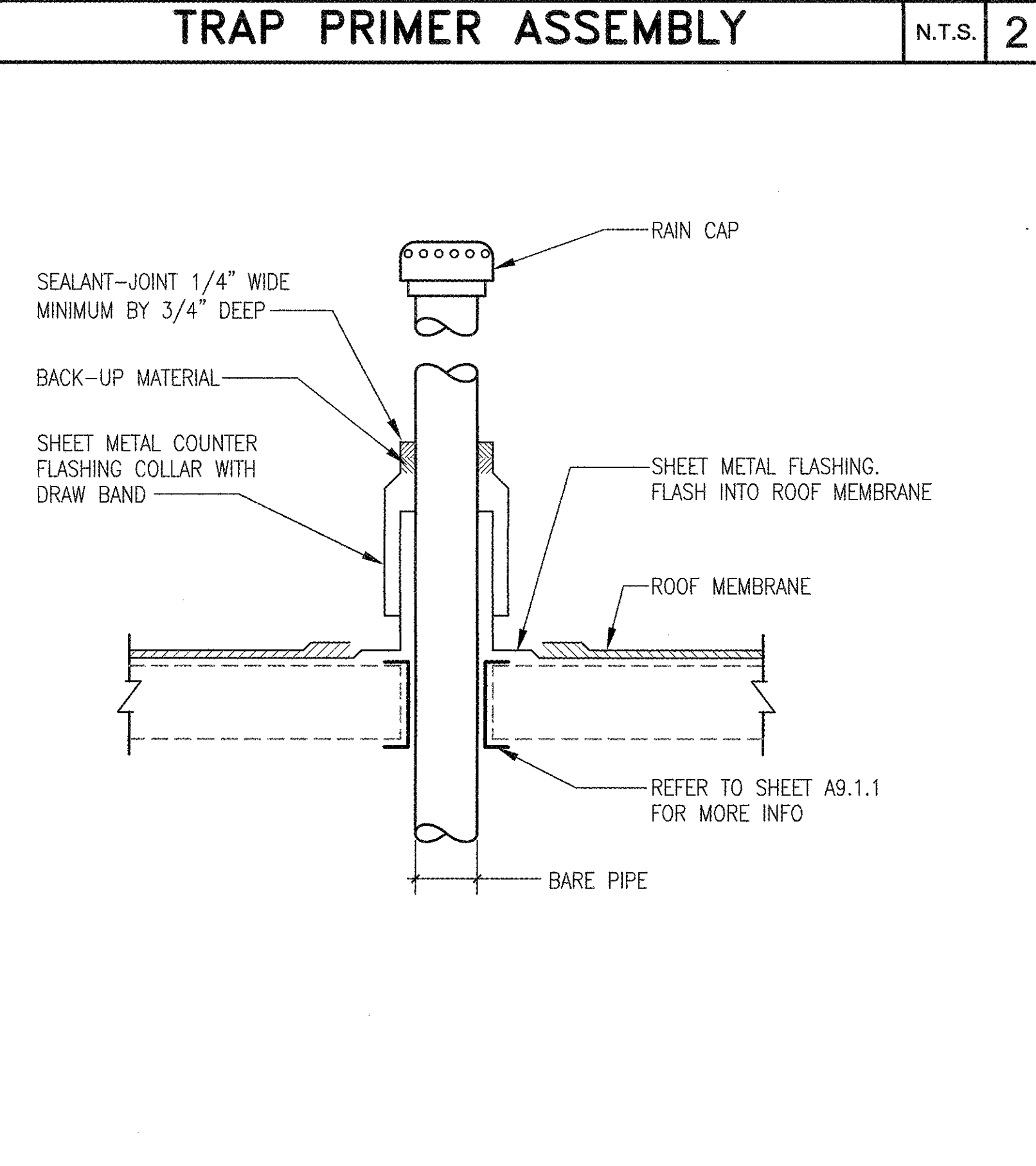

VENT PIPE THRU ROOF

N.T.S. 3

LITTLE
 DIVERSIFIED ARCHITECTURAL CONSULTING
 1300 Dove Street, Suite 100
 Newport Beach, CA 92660
 T: 949.698.1400 F: 949.698.1433
 www.littleonline.com
 This drawing and the design shown are the property of Little Diversified Architectural Consulting. The reproduction, copying or other use of this drawing without their written consent is prohibited and any infringement will be subject to legal action.
 © Little 2016

COMPTON CCD

CAMPUS PUBLIC SAFETY BUILDING
 1111 EAST ARTESIA BOULEVARD,
 COMPTON CALIFORNIA 90221

IDENTIFICATION STAMP
 DIV. OF THE STATE ARCHITECT
 OFFICE OF REGULATION SERVICES
 FILE NO. 19-C1
 AR: 03-117673
 AC: FLS 12/28/16
 DATE: DEC 12 2017

16516
 dHA + CALPEC
 180 S. ARROYO PARKWAY
 SUITE NO. 100
 PASADENA, CA 91105
 TEL: (626) 445-8880
 FAX: (626) 445-8081

PRINCIPAL IN CHARGE
 KEVIN CHEN
 PROJECT MANAGER
 DRAWN BY
 dHA+CALPEC

NO REASON DATE

PLUMBING - DETAILS

913-4675-01

11/21/2017 P5.0.1

DEMOLITION & ALTERATION NOTES

- 1. CONTRACTOR SHALL VISIT THE SITE AND MAKE HIMSELF THOROUGHLY FAMILIAR WITH THE EXISTING CONDITIONS.
2. ALL WORK SHALL BE PERFORMED TO CHANGE THE EXISTING ELECTRICAL INSTALLATION AS INDICATED OR AS REQUIRED TO PERFORM THE NEW WORK...

DEMOLITION/REMODEL:

- (E) WHEN SHOWN ADJACENT TO LIGHTING FIXTURE, PANELS, IN CONDUIT RUNS, ETC., DENOTES EXISTING TO REMAIN.
(EA) WHEN SHOWN ADJACENT TO ELECTRICAL EQUIPMENT DENOTES EXISTING EQUIPMENT TO BE ABANDONED.

SCOPE OF WORK

IN SUMMARY THE ELECTRICAL SYSTEM SCOPE OF WORK NOT LIMITED TO THE ABOVE DESCRIPTION BUT ALSO INCLUDES THE FOLLOWING:

- 1. PROVIDE NEW MAIN SERVICE SWITCHBOARD FOR 208Y/120V, 3PH-4W SERVICE, DISTRIBUTION TRANSFORMERS AND SYSTEM WITH THE NEW BRANCH CIRCUIT PANEL BOARDS.
2. PROVIDE NEW LED SUSPENDED LINEAR LIGHT FIXTURES WITH SEPARATE OCCUPANCY SENSORS AND PHOTO-CONTROL.

ACCESSIBLE MOUNTING HEIGHTS

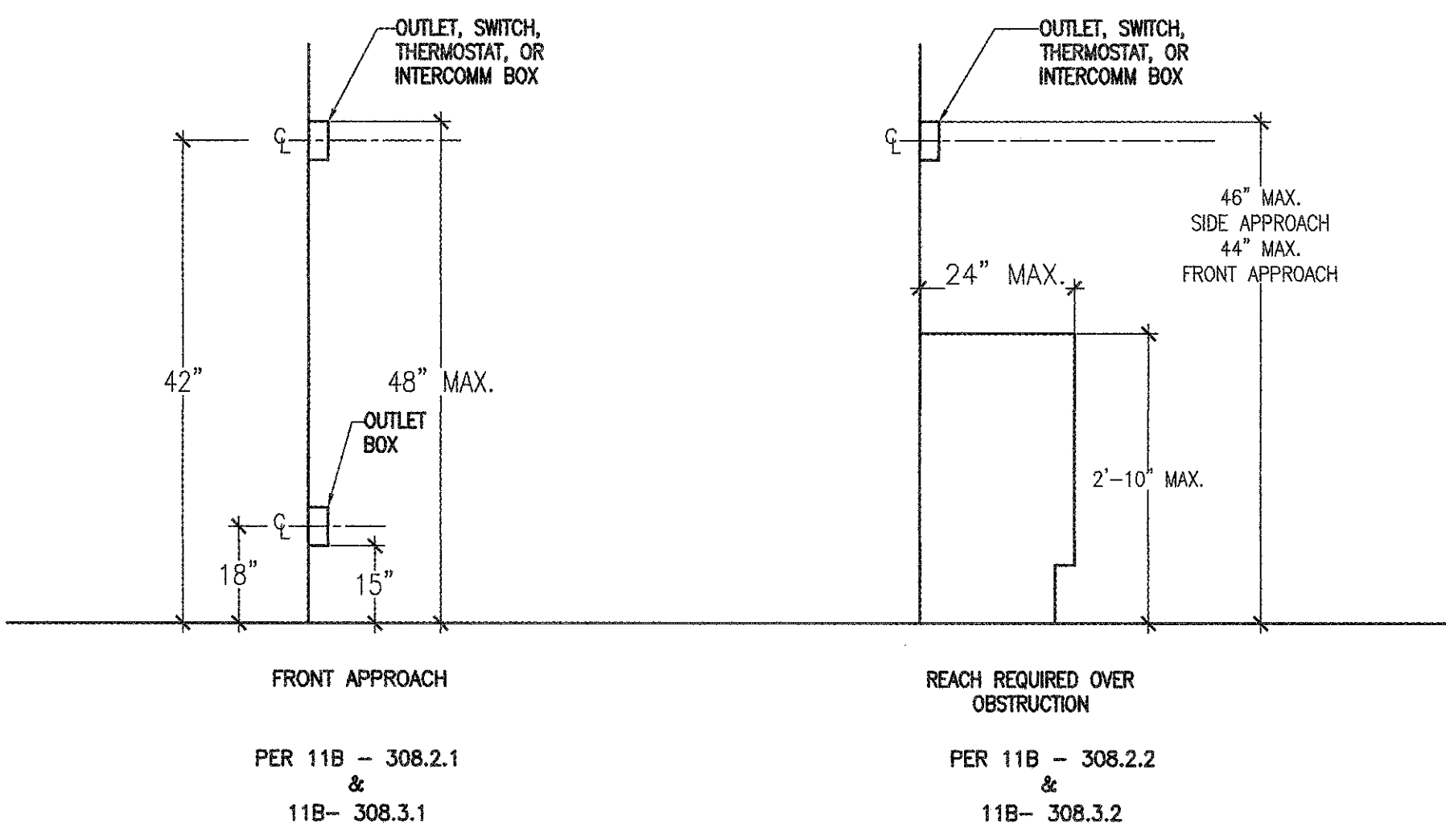

SHEET LIST

- EO.0.1 ELECTRICAL LEGEND AND NOTES
EO.0.2 SINGLE LINE DIAGRAM & SCHEDULES
EO.0.3 LIGHTING FIXTURE SCHEDULE
EO.0.4 ELECTRICAL DETAILS

SYMBOL LIST

GENERAL:

- NEMA 5-20R DUPLEX WHITE RECEPTACLE AT +15'A.F.F. (U.I.O.) AND 3025/S COVER PLATE PASS AND SEYMOUR # 5362W OR EQUAL.
QUADPLEX NEMA 5-20R WHITE RECEPTACLE AT +15'A.F.F. (U.I.O.) AND 3025/S COVER PLATE (2) PASS AND SEYMOUR # 5362W OR EQUAL.

LIGHTING:

- CLG. WALL LIGHTING FIXTURE, "6" DENOTES CIRCUIT NUMBER, "4" DENOTES CONTROLLING SWITCH.
LED LIGHTING FIXTURE.
LED STRIP LIGHTING FIXTURE.

OCCUPANCY SENSOR FOR LIGHTING CONTROL SYSTEM NOTES:

- OCCUPANCY SENSOR (NOT PART OF LIGHTING CONTROL PANEL) FOR LIGHTING CONTROL SYSTEM SHALL BE BY "GREENBATES" (COOPER CONTROLS), WITH THE FOLLOWING PRODUCT NUMBERS:
1. WALL MOUNTED SENSOR: PIR TECHNOLOGY, AUTO OR MANUAL ON FOR PRIVATE/SMALL OFFICE, CONFERENCE ROOM AND STORAGE.

COMMUNICATION SYSTEMS SYMBOL:

- WALL PHONE OUTLET WITH COVER PLATE, AT +48"A.F.F. (U.I.O.) ONE CAT5 CABLE DROP - PROVIDE SINGLE GANG BOX WITH 16 FACE PLATE AND 3/4"C STUB-UP INTO ACCESSIBLE CEILING SPACE U.O.N.
DATA OUTLET WITH COVER PLATE, AT +15'A.F.F. (U.I.O.) SUBSCRIPT INDICATES NUMBER OF DATA DROPS (CAT-6) - PROVIDE 4S J-BOX WITH 16 FACE PLATE AND 3/4"C STUB-UP INTO ACCESSIBLE CEILING SPACE U.O.N.

LOW VOLTAGE SYSTEMS SYMBOL:

- SECURITY SYSTEM CAMERA. PROVIDE/INSTALL FLUSH AS BOX (WP FOR EXTERIOR LOCATIONS) WITH SEAL/TITE CONDUIT WHIP TO CAMERA.
SECURITY/INSTRUTION SYSTEM CARD READER. PROVIDE/INSTALL FLUSH AS OUTLET BOX. MOUNT AT +48" TO CENTER.

LOW VOLTAGE/COMMUNICATION CABLE LEGEND:

- REFER TO SPECIFICATION DIVISION 27 & 28 FOR LOW VOLTAGE CABLE REQUIREMENT. PROVIDE IN MINIMUM 3/4"C U.O.N.
ALL LISTED CABLES BELOW SHALL BE CONTRACTOR FURNISHED, CONTRACTOR INSTALLED, U.O.N.

GENERAL NOTES

- 1. ALL MATERIALS AND WORKMANSHIP SHALL CONFORM TO THE 2013 CALIFORNIA ELECTRICAL CODE (CEC) AND ALL APPLICABLE LOCAL CODES AND REGULATIONS:
2013 CALIFORNIA ELECTRICAL CODE
2013 CALIFORNIA FIRE CODE
2013 CALIFORNIA BUILDING CODE
2013 CALIFORNIA MECHANICAL CODE
2013 CALIFORNIA PLUMBING CODE
2013 CALIFORNIA ENERGY CODE

MEP COMPONENT ANCHORAGE NOTES

- 1. MECHANICAL, PLUMBING, AND ELECTRICAL COMPONENTS SHALL BE ANCHORED AND INSTALLED PER THE DETAILS ON THE APPROVED CONSTRUCTION DOCUMENTS. WHERE NO DETAIL IS INDICATED, THE FOLLOWING COMPONENTS SHALL BE ANCHORED OR BRACED TO MEET THE FORCE AND DISPLACEMENT REQUIREMENTS PRESCRIBED IN THE 2013 CALIFORNIA BUILDING CODE, SECTIONS 1616A.1.18 THROUGH 1616A.1.26 AND ASCE 7-10 CHAPTER 6 AND 30.
A. PERMANENT EQUIPMENT AND COMPONENTS.

SIESMIC BRACING NOTES

- 1. SEISMIC BRACING AND ANCHORAGE OF PIPING, DUCTWORK, AND SUSPENDED EQUIPMENT SHALL BE PROVIDED USING A SEISMIC RESTRAINT MANUAL THAT BEARS AN OSGPD ANCHORAGE PRE-APPROVAL NUMBER: OPA-0349 MASON INDUSTRIES "SEISMIC RESTRAINT GUIDELINES FOR SUSPENDED PIPING, DUCTWORK, AND ELECTRICAL SYSTEMS", NO. OPA-0485 1.5A.1, "ENGINEERED SEISMIC BRACING OF SUSPENDED UTILITIES", OR APPROVED EQUAL.
A. A COPY OF OSGPD PRE-APPROVED SYSTEMS INSTALLATION GUIDE/MANUAL SHALL BE PROVIDED BY THE CONTRACTOR PRIOR TO STARTING INSTALLATION AND KEPT ON THE JOB SITE.

ABBREVIATIONS

- A AMPERES.
A/C AIR CONDITIONING.
AFF ABOVE FINISHED FLOOR.
AFG ABOVE FINISHED GRADE.
AIC AMPERES INTERRUPTING CAPACITY.

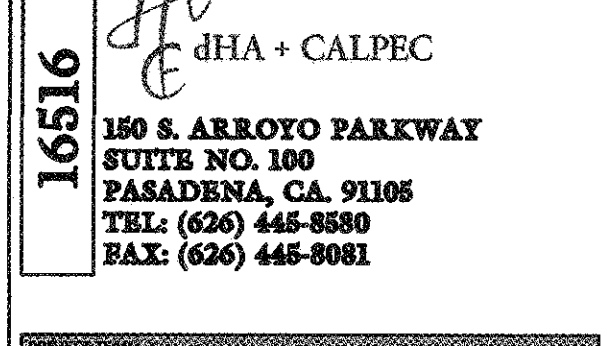
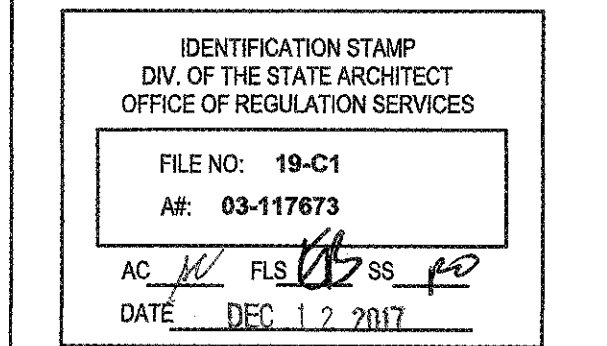
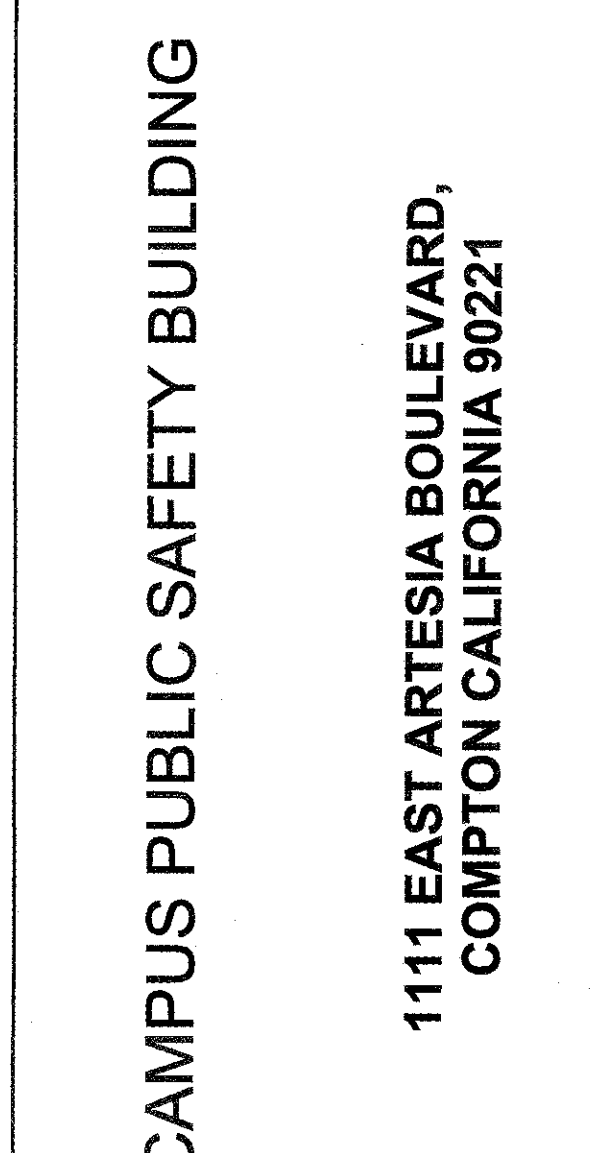

PRINCIPAL IN CHARGE KEVIN CHEN
PROJECT MANAGER KEVIN CHEN
DRAWN BY dHA+CALPEC

NO REASON DATE



ELECTRICAL LEGEND AND NOTES

- PC PHOTO CELL
PH PHASE
PNL PANEL.
PWS POWER.

913-4675-01
11/21/2017 EO.0.1

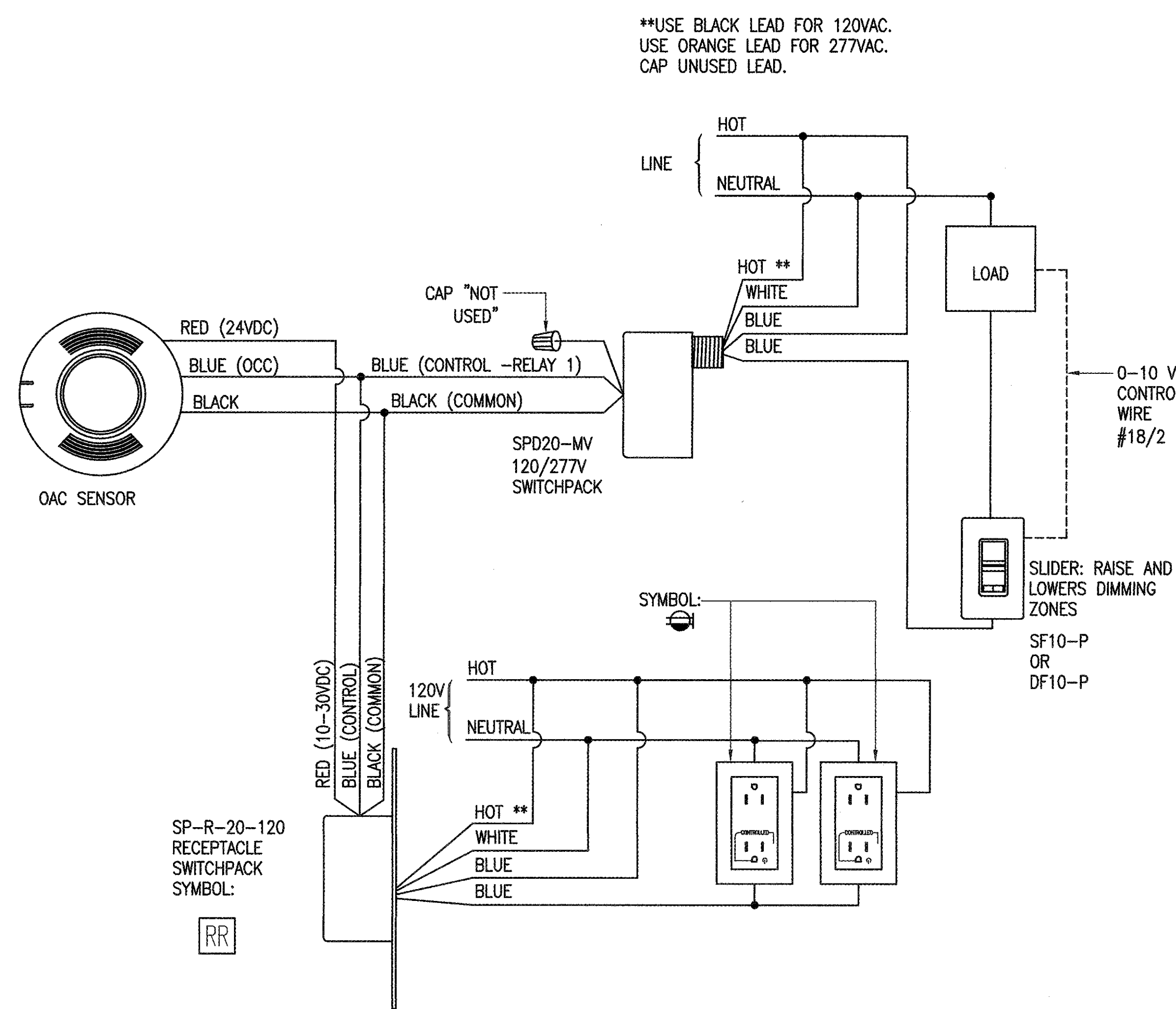

2 LIGHTING AND RECEPTACLE CONTROL WIRING DETAIL

ROOM CONTROLLER AND SMART DEVICES USE CLICK & GO TECHNOLOGY:

THE RC3DE WILL AUTOMATICALLY RECOGNIZE ANY SMART DEVICE CONNECTED WITH THE QUICK CONNECT CABLE (PROVIDED) AND START WORKING IMMEDIATELY UPON POWER UP WITH NO PROGRAMMING REQUIRED. THE RC3DE DEFAULTS TO MANUAL ON/AUTOMATIC OFF VACANCY SENSOR MODE FOR MAXIMUM ENERGY SAVINGS. OFFICE WALLSTATIONS WILL PROVIDE ON/OFF/PRESET/RAISE/LOWER CONTROL OF THE LIGHTING LOADS AND DIMMERS. THE DAYLIGHT SENSOR WILL AUTOMATICALLY ON POWER UP PROVIDE MULTI-ZONE DAYLIGHT DIMMING IN THE SPACE. (REMOTE ADJUSTMENTS CAN BE MADE LATER)

EMERGENCY NOTE:

EMERGENCY LOAD TRACKS WITH NORMAL LIGHTING YELLOW LOAD FOR ON/OFF. IF DIMMING IT WILL BE ADJUSTED WITH THE DIMMING ZONE IT IS CONNECTED TO. UPON LOSS OF NORMAL POWER TO THE RC3DE, THE EMERGENCY LOAD WILL BE FORCED ON AND FULL BRIGHT TO 100%. EMERGENCY RELAYS ARE ONLY AVAILABLE WITH THE RC3DE MODEL. RC3DE IS UL924 LISTED. 0-10V DIMMING CONNECTION 0-10V DIMMING ZONE NOTE: THE 0-10V DIMMING ZONES WITHIN THE ROOM CONTROLLER CAN BE WIRED AND CONTROLLED INDEPENDENT OF THE CONNECTED LOADS. THIS ALLOWS EACH LOAD TO HAVE A DEDICATED 0-10V DIMMING ZONE OR A SINGLE LOAD TO HAVE UP TO THREE 0-10V DIMMING ZONES.

NOTES

- 1) Refer to plans for locations and quantity.
- 2) Refer to all manufacturers installation instructions for correct wiring information
- 3) Each Occupancy sensors and BMS output requires an OCC-RJ45
- 4) Each Room Controller can power up to 4 Wallstations and 5 Receptacle Controls
- 5) Each Room Controller can power up to 2 Occupancy sensors and 1 Daylight sensor
- 6) Daylight sensors can only be used for Room Controllers with dimming capability

CABLE

- LV3 Low Voltage Input wire - #18 AWG, 3 conductor wire
- LV2 Low Voltage Input wire - #18 AWG, 2 conductor wire
- QC Quick Connect Cable, Pre-terminated RJ45 - Category 5
- QC Cables provided by Cooper Controls

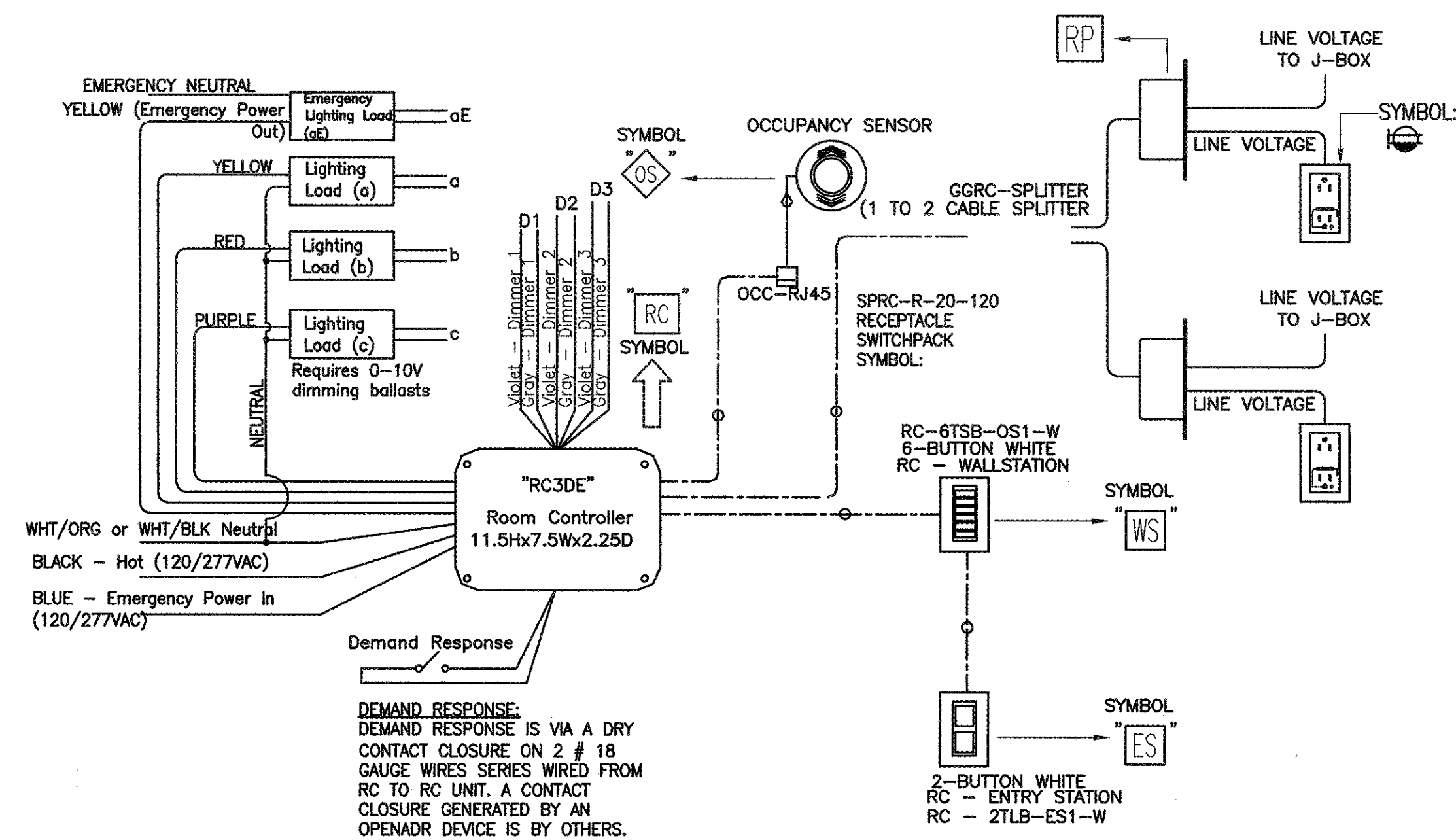

3 ROOM CONTROLLER WIRING DETAIL

GENERAL NOTES:

1. SEE LIGHTING AND POWER PLAN E2.3-1 & E2.3-2 FOR DEVICE REQUIREMENTS IN EACH ROOM.
2. LIGHTING: COOPER SPD20-MV-NO SWITCH PACK. 120/277VAC. RECEPTACLE: SP-R-20-120 SWITCH PACK OR EQUAL 20AMP RATING PER RELAY.
3. BLUE AND RED WIRE LEADS ARE NON-POLARITY SENSITIVE.
4. COOPER OAC-P-500 CEILING OCCUPANCY SENSOR OR EQUAL SHOWN.

FIXTURE SCHEDULE

FIXTURE SYMBOL	FIXTURE DESCRIPTION	DIMMING SPEC'D	PRODUCT ID#	LAMPS, LUMENS, KELVIN, CRI, BUG	VOLT	WATTS	QTY	MOUNTING, LOCATION
16	4" RECESSED DOWNLIGHT, CUSTOM ALZAK RFL	0-10V	CLJ-NACSB8A	LEDM OSRAM, 1000LM, 3500K	120	16	34	LOBBY, SERVICE WINDOW & DISPATCH AREA, RECESSED, 9"0" OR 8"0" AT HALLWAY
17	12" RECESSED DOWNLIGHT, CONTROL W/0-10V DAYLIGHT HARVESTING SENSOR	0-10V	CLJ-NACSB01	LEDM, 1100LM, 3500K	120	16	14	TOILET & SHOWER, CORRIDORS, WATCH STATION & BREAK, LAYIN GRID CEILING
18	2X4 CENTER BASKET LED LAYIN	0-10V	CLJ-NACSB84	LEDM, 3800LM, 3500K	UNV	37	20	LAYIN GRID CEILING, OFFICES
19	SAME AS TYPE B BUT W/FLANGE KIT	0-10V	CLJ-NACSB84F	LEDM, 3800LM, 3500K	UNV	37	8	INTERVIEW ROOMS & SECURE EVIDENCE, RECESSED IN SHEETROCK AT 9"0"
20	2X4 LENSED LED LAYIN W/FLANGE KIT	0-10V	CLJ-NACSB8C	LEDM, 3300LM, 3500K	UNV	31	3	ARMORY, RECESSED IN SHEETROCK AT 8"0"
21	STRIP, LED, LENSED 4'	0-10V	CLJ-NACSB8E	LEDM, 3800LM, 3500K	UNV	39	12	ELECTRICAL, STORAGE, SUSPENDED, OPEN CEILING & FLUSH MT IN TOILETS & CUSTODIAL
22	SAME AS TYPE E BUT HIGHER LUMENS	0-10V	CLJ-NACSB8EE	LEDM, 4800LM, 3500K	UNV	54	1	GUINS CLEANING, SUSPENDED, OPEN CEILING
23	6" RECESSED DOWNLIGHT, GLASS LENS, CUSTOM WHITE SPLAY	0-10V	CLJ-NACSB8F	LEDM OSRAM, 951LM, 3500K	120	16	2	RECESSED IN SHOWERS
24	WALL CYLINDER, EXTERIOR RATED, DOWNLIGHT ONLY, BLACK	120V	CLJ-NACSB8G	LEDM, 1500LM, 3500K	120	22	4	OVER SIDE & REAR CORRIDOR ENTRANCES
25	SAME AS G BUT SILVER	120V	CLJ-NACSB8GF	LEDM, 1500LM, 3500K	120	22	15	SURFACE MT AT EXTERIOR SOFFIT
26	4" IN-GROUND LIGHT, STAINLESS STEEL	120V	CLJ-NACSB8H	LEDM, 250LM, 3500K	12V	3	3	RECESSED AT FAÇADE WINDOWS
27	4" WALLWASH DOWNLIGHT, CUSTOM ALZAK RFL, WHITE TRIM, WET LOCATION	0-10V	CLJ-NACSB8J	LEDM, 1000LM, 3500K	120	16	20	RECESSED AT LOBBY, OPEN OFFICE & MEETING ROOM
28	4' LED LINED COVE, OPTICS 30X60	0-10V	CLJ-NACSB8L1	LEDM, 1000LM/FT, 3500K	UNV	48	12	SURFACE MT AT SKYLIGHTS
29	SAME AS TYPE L1 BUT 1'	0-10V	CLJ-NACSB8L2	LEDM, 1000LM, 3500K	UNV	12	12	SURFACE MT AT SKYLIGHTS
30	LED STRIPLIGHTING, 1/2" WIDE, FIELD CUTTABLE EVERY 2", MAX RUN 16', WITH CHANNEL & 0-10V DIMMABLE DRIVER	0-10V	CLJ-NACSB8L3	LEDM, 370LM/FT, 3500K	120/24	4.4W/FT	14'	SURFACE MT AT ENTRANCE
31	EXTERIOR BLUE LED NEON ROOF TUBE LIGHTING, WITH EXTRUSION, DRIVERS AND ACCESSORIES.	NON	CLJ-NACSB8L4	LEDM, 40LM/FT, 12W/FT	120	12	137'-10"	LTC VENDOR TO PROVIDE ALL REQUIRED ACCESSORIES FOR FULL INSTALLATION. REFER TO A.9.1.1.3. comp. II.
32	LED STRIPLIGHTING, 1/2" WIDE, FIELD CUTTABLE EVERY 2", MAX RUN 16', WITH CHANNEL & 0-10V DIMMABLE DRIVER	0-10V	CLJ-NACSB8L3	LEDM, 700LM/FT, 3500K	120/24	8.8W/FT	17'	SURFACE MT AT ENTRANCE SOFFIT COVE
33	48" ADJUSTABLE MOUNT SIGNAGE LIGHT	NON	CLJ-NACSB8L5	LEDM, 4000LM, 4200K	UNV	74	4	MOUNTED TO THE CANOPY OVERHANG EDGE TO LIGHT SIGNAGE. REFER TO A.9.1.1.3. comp. II.
34	INTEGRAL SIGNAGE LIGHT STRIP (OPTION 2)	NON	CLJ-NACSB8L2	LEDM, 360LM/FT, 3500K	120/24	4W/FT	TBD	MOUNTED WITHIN THE SIGNAGE TO BACKLIGHT ACRYLIC PANELS
35	SOLATURE 14" ACRYLIC DOME, 6" FLAT/NO PITCH METAL, SELF MOUNTED, 2 EXTENSION TUBES MAX60", CLASSIC DIFFUSER, NATURAL EFFECT LENS, W/CF LIGHT KIT	NON	CLJ-NACSB8T2	3500LM, 6430K AT FULL SUNLIGHT + CF2800/E	N/A	28	13	TOILET & SHOWER, CORRIDORS, WATCH STATION & BREAK. REFER TO A.9.1.1.3.
36	SOLATURE 21" CLOSED CEILING, ACRYLIC DOME, 8" SELF MOUNTED, 1 EXTENSION TUBE MAX60", PRISMATIC DIFFUSER	NON	CLJ-NACSB8T3	3500LM, 6430K AT FULL SUNLIGHT	N/A	N/A	8	LOCKERS AREAS. REFER TO A.9.1.1.3.
37	PARKING LOT POLE LIGHT, TYPE III DISTRIBUTION WITH PHOTOCELL & MOTION SENSOR, DARK BRONZE, 15" LONG 4" ROUND STRAIGHT STEEL POLE, 11GA	120V	LITHONIA DSXO - SERIES	LED 15010LM, 4000K LED DRIVER (120VAC) WITH PHOTO CELL CONTROL	MV	138	3	MOUNT ON CONCRETE PEDESTAL. REFER TO E.0.0.6.7.
38	EXIT, EDGE LIT BLADE, LED, RED OR GREEN ON CLEAR OR WHITE, WHITE, BLACK OR ALUMINUM COLOR HOUSING, SELF POWERED OR AC. WALL RECES AVAILABLE.	NON	SURE-LITES ELX7-R (ALUMHSG)	LEDM	DV	2	2	CEILING RECESSED, WALL RECESSED AVAILABLE
39	EXIT, SNS/OBL RED/GRN ON WHITE, UNIV MT, SELF POW	NON	SURE-LITES LPX-7	LEDM	DV	2	2	UNIVERSAL WALL OR CEILING
40	UNIV EXIT W/2 HD EMERG COMBO	NON	SURE-LITES LPX-7-DH	LEDM & 2-LEDM	DV	4	4	WALL MT
41	EMERGENCY LIGHT, UNIVERSAL MOUNT, WHITE	NON	SURE-LITES SEL17	2-LEDM	DV	2	2	UNIVERSAL WALL OR CEILING, SEL60 AVAIL FOR HIGHOUTPUT
42	EMERGENCY LIGHT, RECESSED GIMBAL, WHITE, 6V	NON	SURE-LITES RG2-WH	25W 6V-PIN HALOGEN SEALED BEAM PAR36	DV	25	25	RECESSED
43	EMERGENCY LIGHT, RECESSED 9"X13" WHITE	NON	SURE-LITES RLM2	2-6V 9PAR36 HALOGEN	DV	18	18	RECESSED
44	4FT NARROW LED LENSED STRIPLIGHT.	0-10V	METALLIX-4SNLED-LD4-34SL-LC-UNV-L840-CD1-U	LED 4000K 3431LM	120-277	28	4	SURFACE CEILING EX/UTILITY RMS.

FIXTURE SCHEDULE NOTES:

1. THE FIXTURE SCHEDULE INDICATES GENERAL DESCRIPTIONS OF LIGHTING FIXTURE AND SPECIFIC MANUFACTURER CATALOG NUMBERS. IT SHALL BE CONTRACTOR'S RESPONSIBILITY TO VERIFY EACH FIXTURE'S EXACT LOCATION AND PROVIDE WITH NECESSARY TRIMS AND MOUNTING HARDWARE MATCHING REFLECTED CEILING PLAN AND CEILING SYSTEM PER-ARCHITECTURAL DRAWINGS.
2. WHERE ONLY ONE FIXTURE TAG SHOWN IN AN AREA OR ROOM ON THE LIGHTING PLAN, THE TAG SHALL APPLY TO ALL FIXTURES IN THAT AREA OR ROOM, UNLESS OTHERWISE NOTED.
3. CONTRACTOR SHALL BE RESPONSIBLE TO PROVIDE IN THE SHOP DRAWING SUBMITTAL ALL CUT-SHEETS OF THE SPECIFIED LIGHTING FIXTURES WITH SPECIFIED LED CHARACTERISTIC AND DRIVER INDICATED ON SCHEDULE. INCOMPLETE SUBMITTAL WILL NOT BE REVIEWED AND RETURNED FOR COMPLETE RE-SUBMITTAL.
4. CONTRACTOR SHALL BE RESPONSIBLE TO COORDINATE INSTALLATION OF LIGHT FIXTURE LOCATION IN MECHANICAL, ELECTRICAL AND OTHER EQUIPMENT ROOMS WHERE CONDUITS, DUCT WORKS, PIPINGS AND ETC. ARE PRESENT TO AVOID CONFLICT AND ENABLE PROPER ILLUMINATION DISTRIBUTION IN THE ROOM.
5. PROVIDE FIXTURE WITH SET OF END CAPS LN-CK-5-AC & LN-CK-0-AC AS REQUIRED.
6. FIXTURE WITH INVERTER ISI ABC 125 277V, 125W INVERTER FOR SURFACE CEILING INSTALLATION FOR ASSIGNED EMERGENCY EGRESS FIXTURES. (TYPICAL ONE INVERTER PER-CLASSROOM)
7. PROVIDE FIXTURE WITH CREE SMARTCAST 0-10V INTERFACE DEVICE CAT #CIF-10V AND #CWC-SNSR
8. INTEGRAL SMART CAST MODULE EQUIPPED LIGHT FIXTURE SHALL BE CONTROLLED BY CREE DIMMER SWITCH # CWD CWC WH/CFP1WH

1 LIGHTING FIXTURE SCHEDULE & NOTES

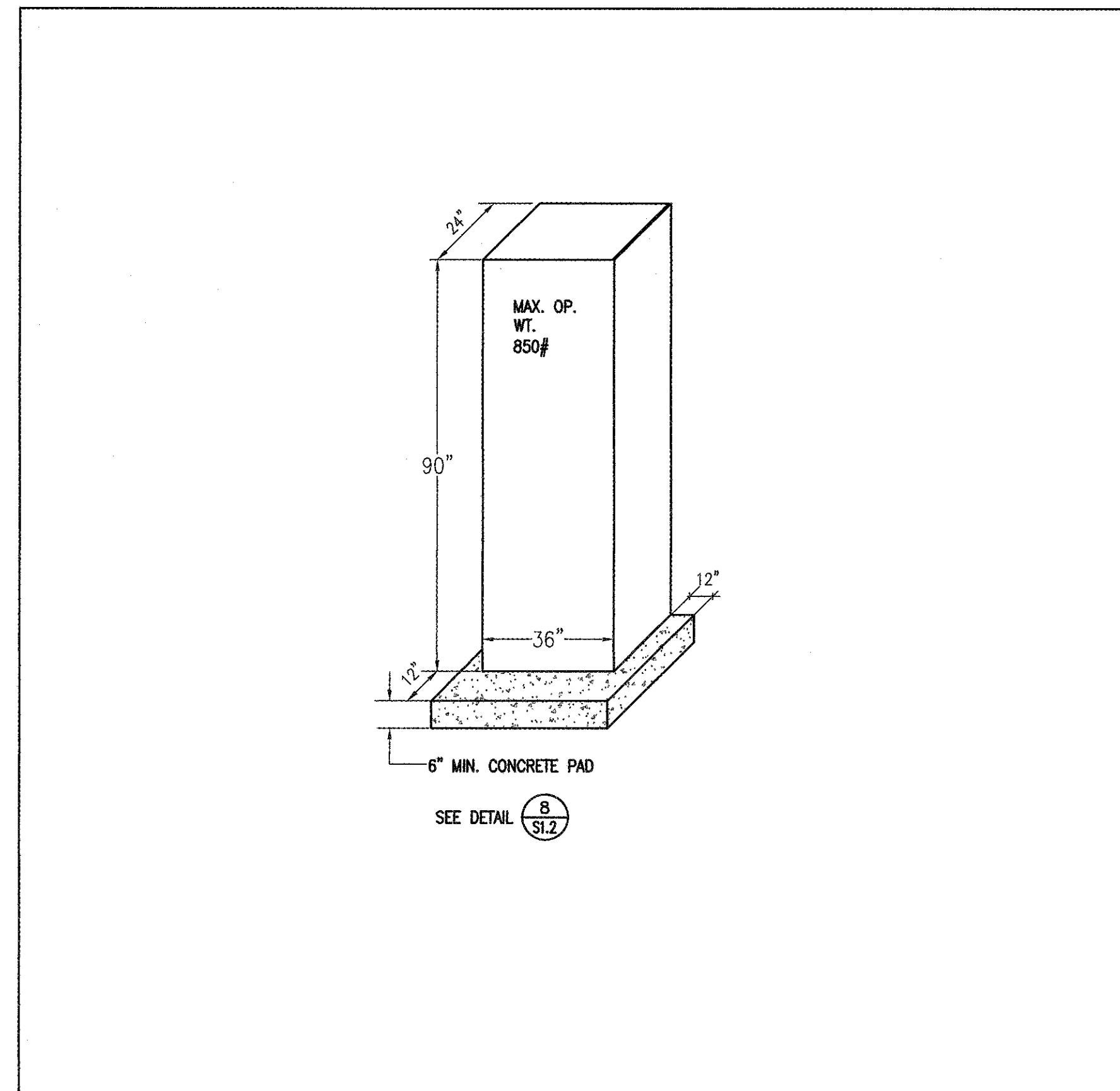

SWITCHBOARD "MSB" - ELEVATION N.T.S. 1

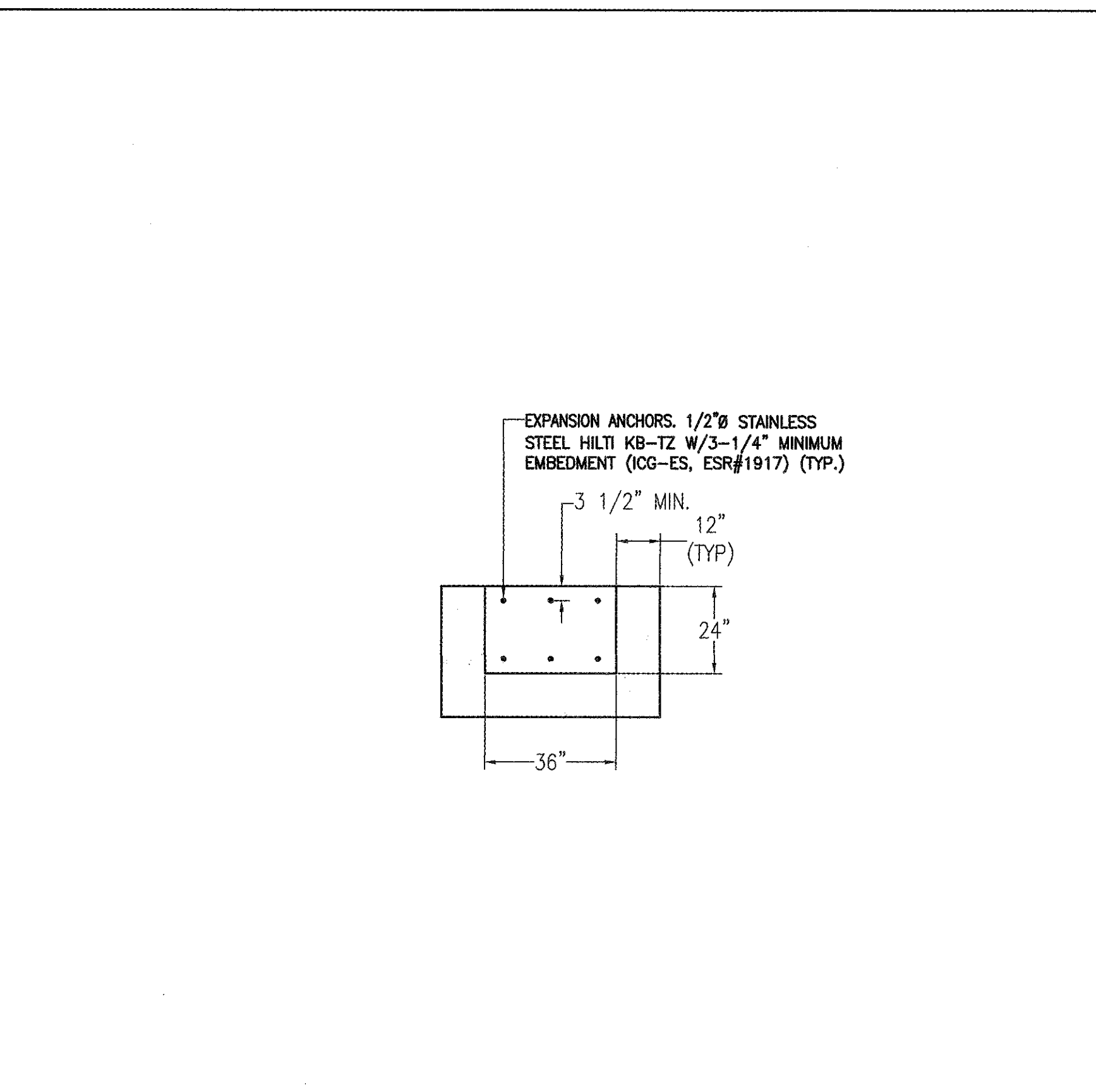

SWITCHBOARD "MSB" ANCHORAGE N.T.S. 2

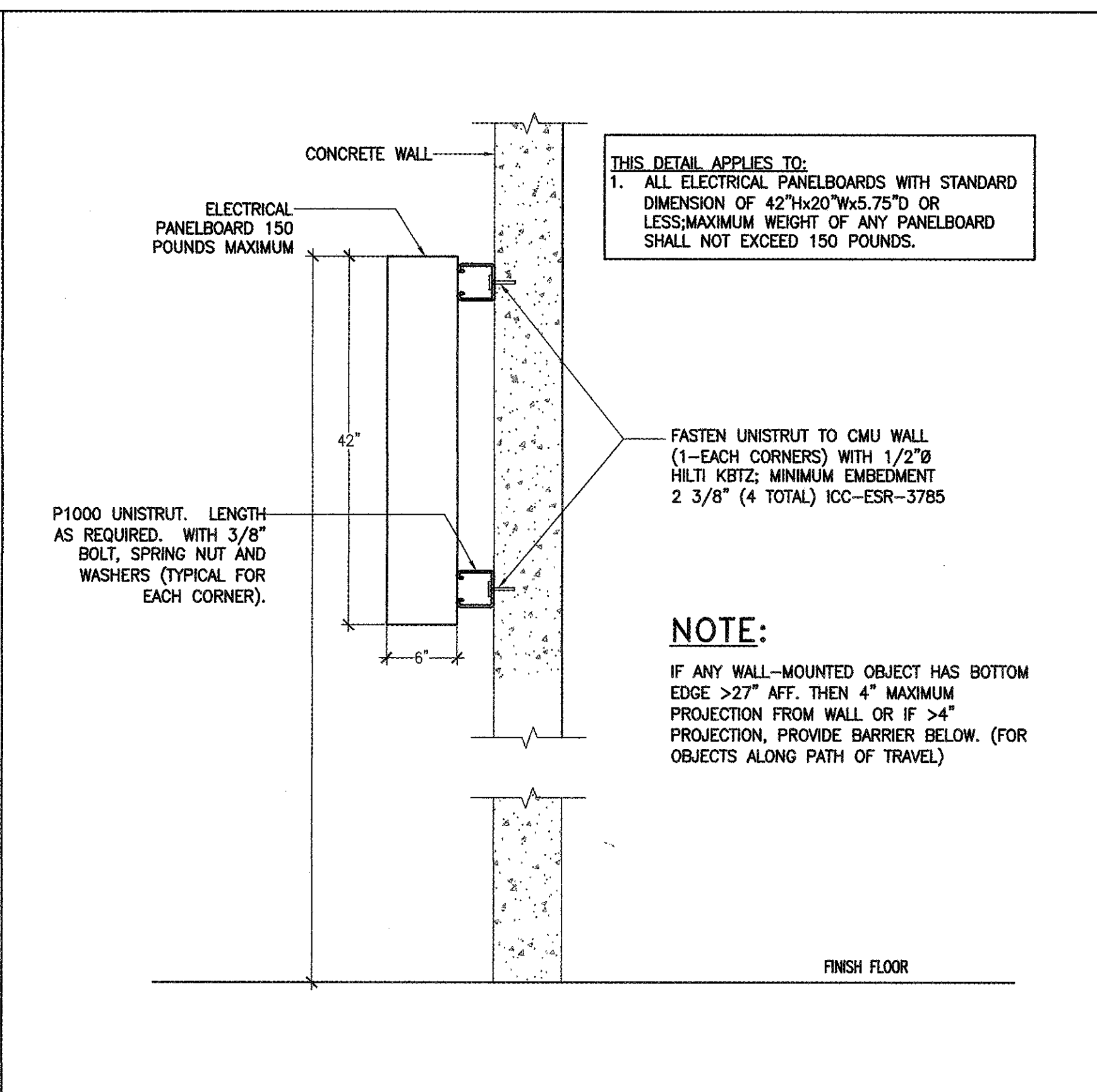

SURFACE MOUNTED PANELBOARD ON CONCRETE WALL DETAIL N.T.S. 3

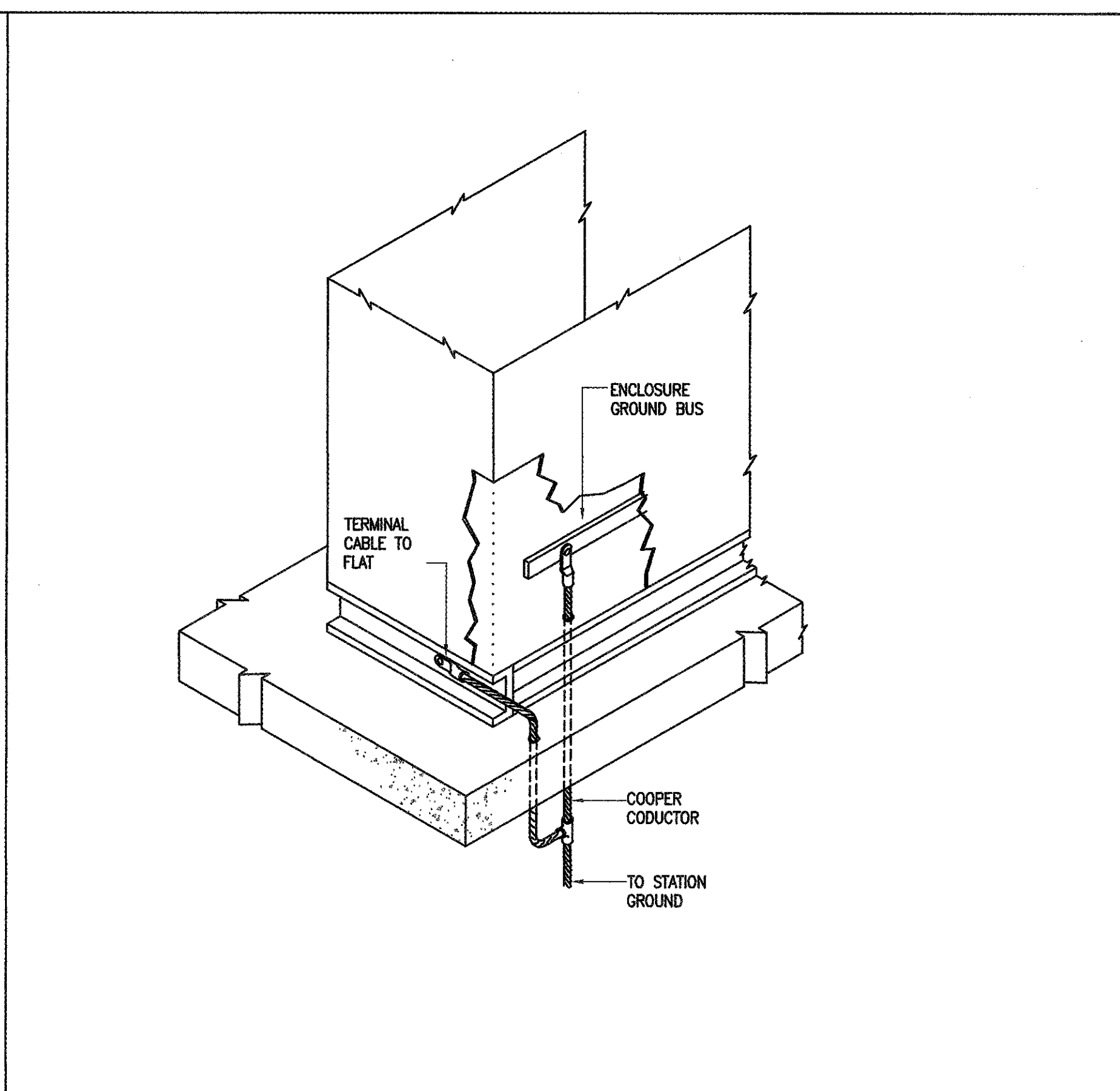

MAIN SWITCHBOARD GROUNDING N.T.S. 4

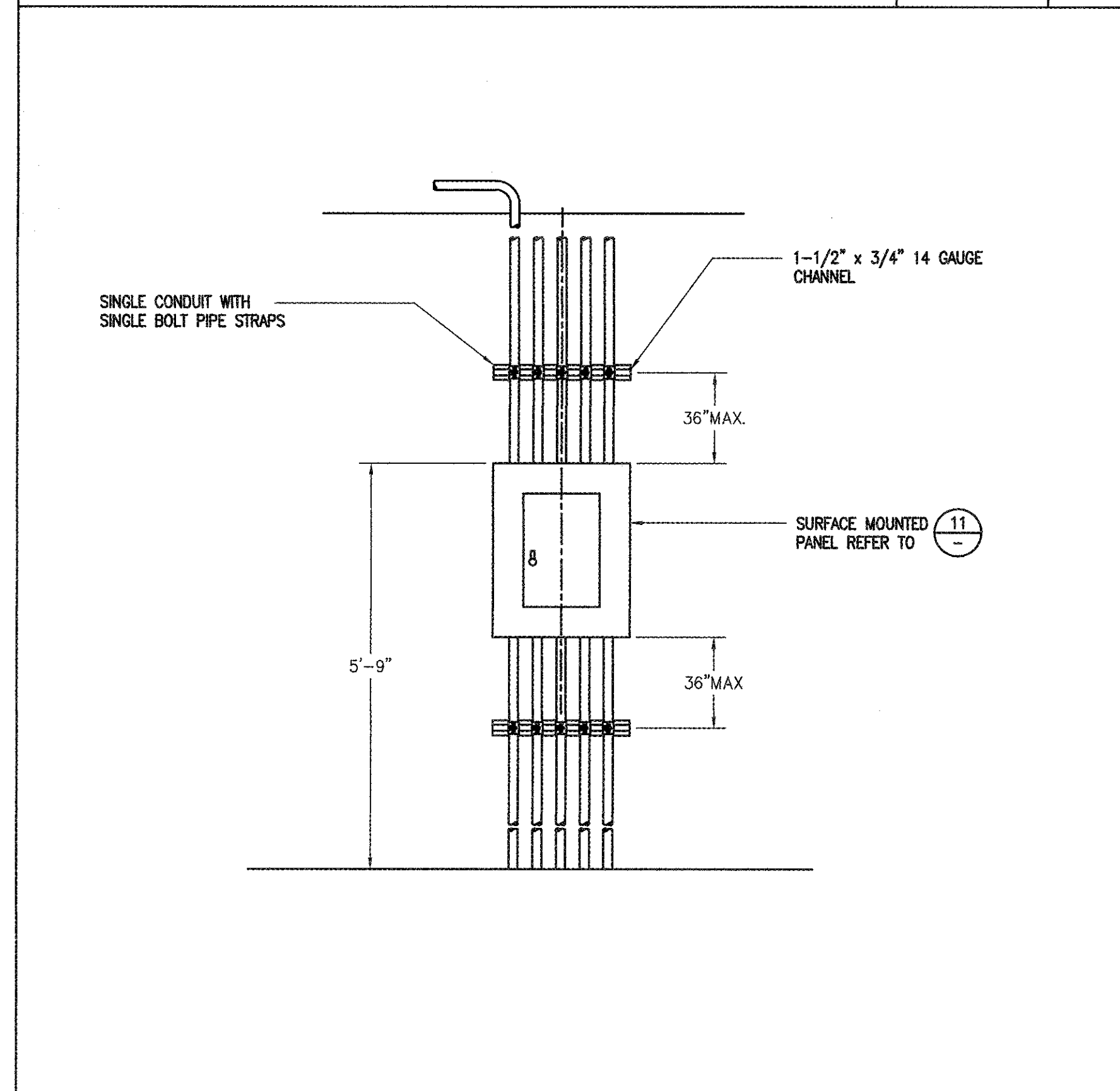

CONDUIT SUPPORT DETAIL N.T.S. 5

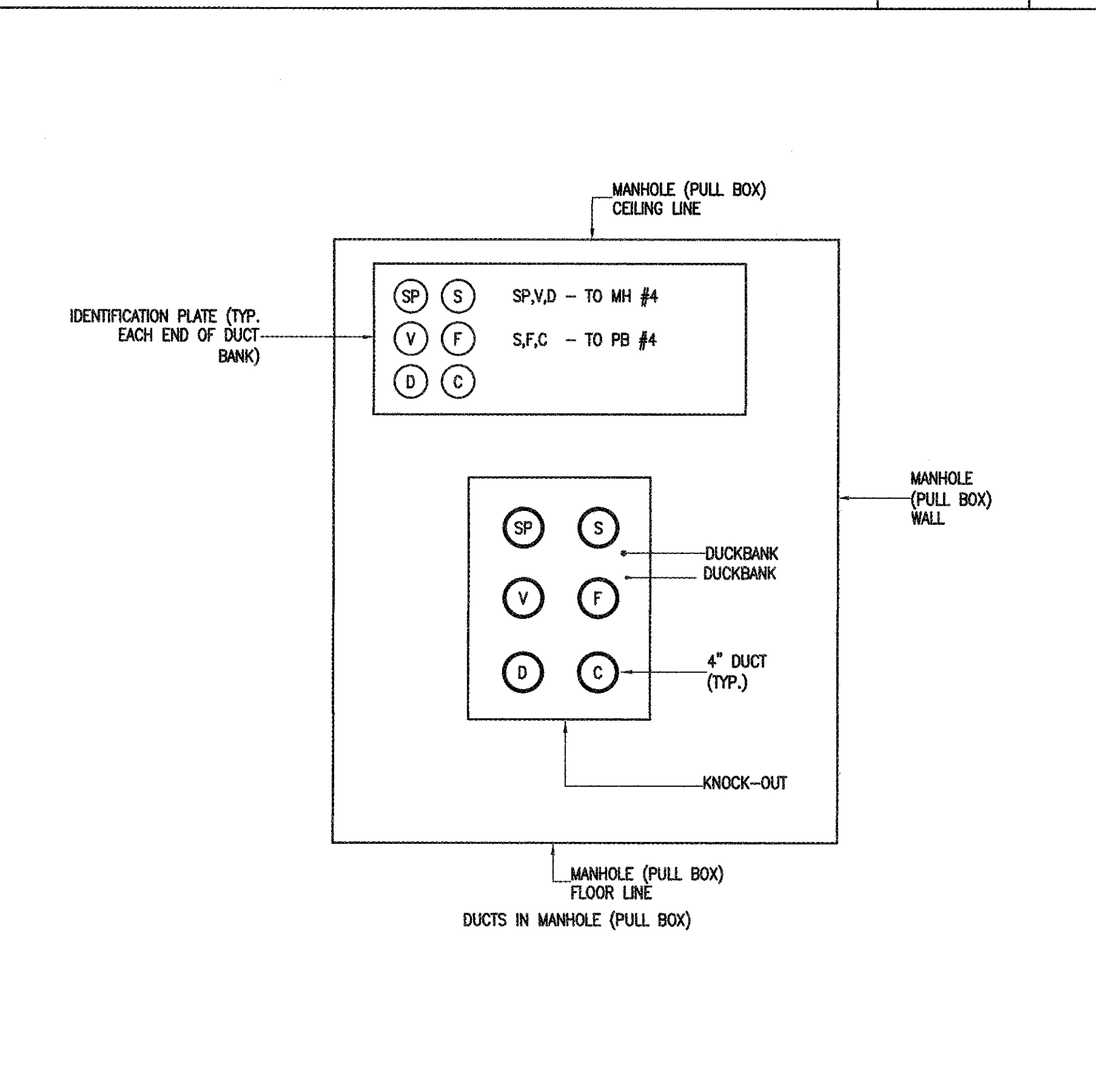

TYPICAL IDENTIFICATION PLATE N.T.S. 6

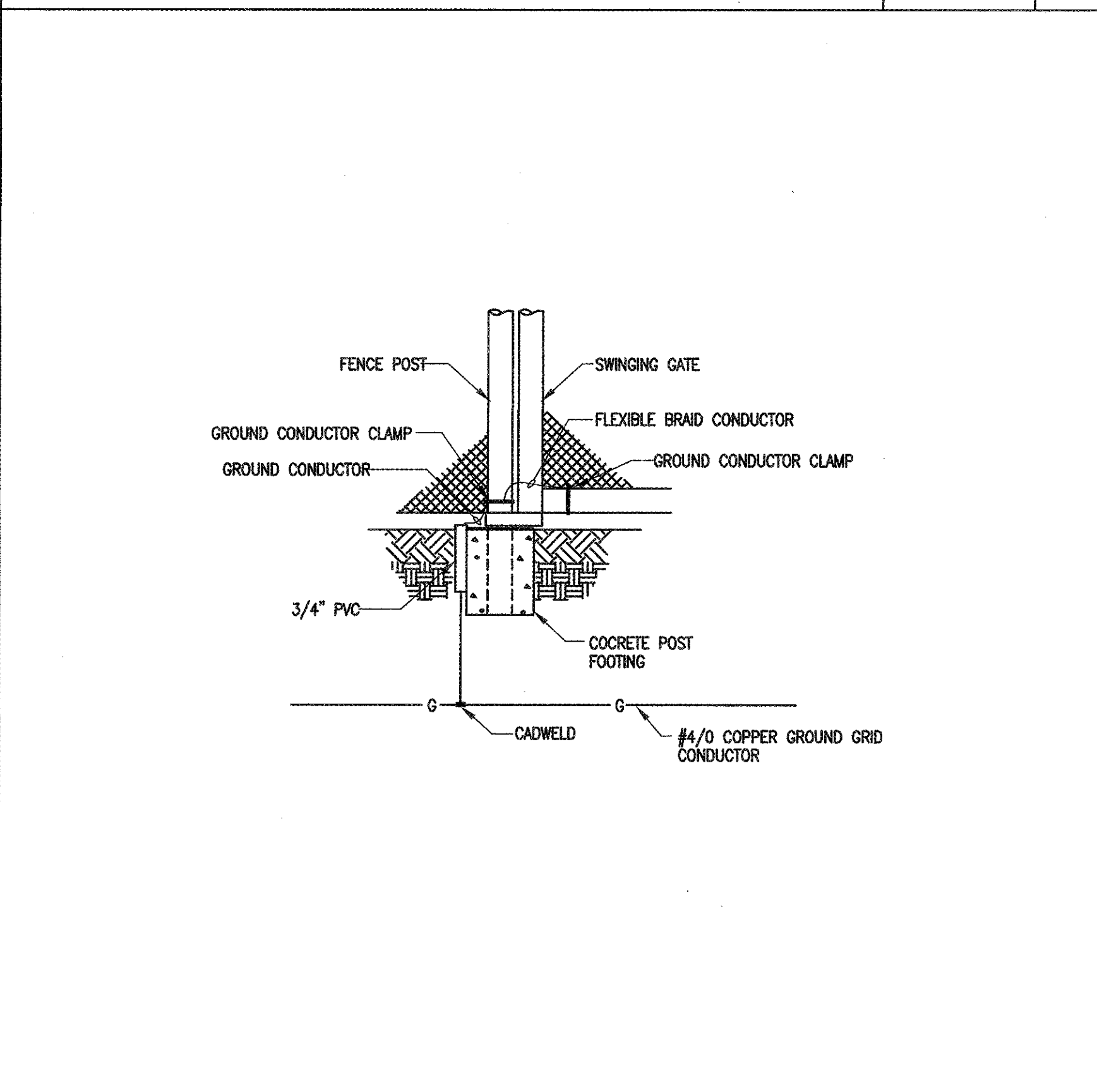

FENCE GATE GROUNDING DETAIL N.T.S. 7

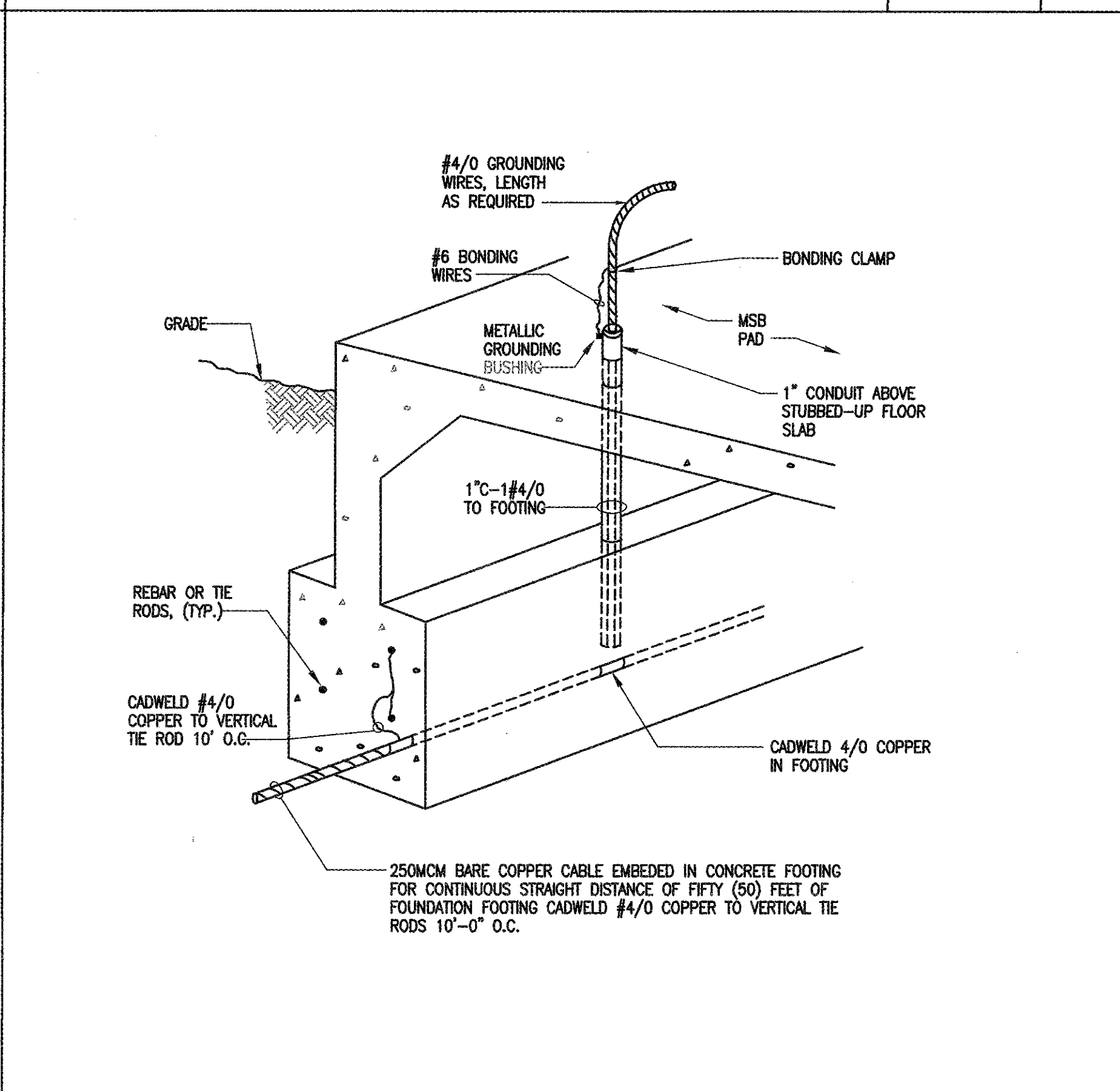

UFER GROUNDING DETAIL N.T.S. 8

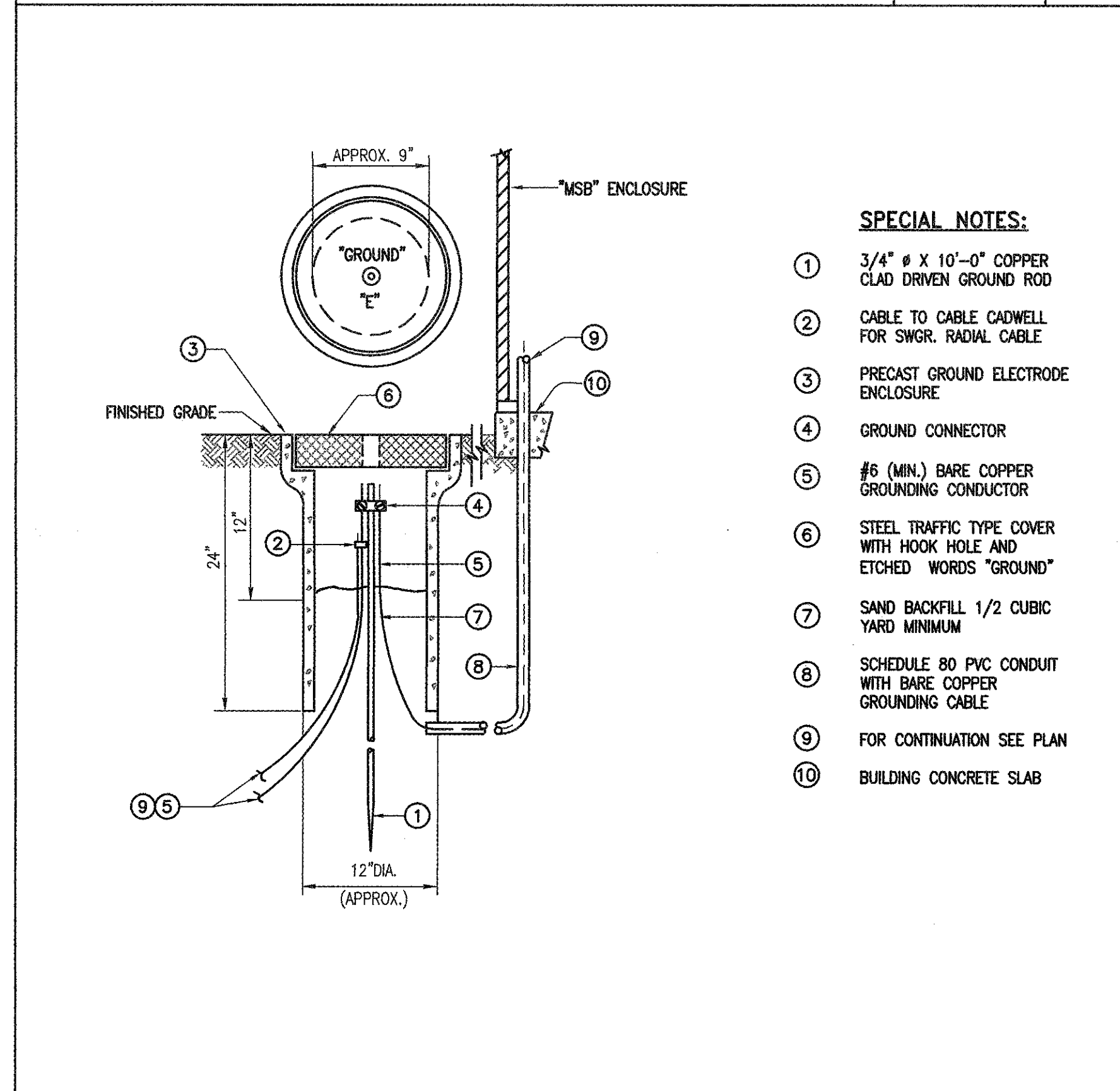

GROUND WELL N.T.S. 9

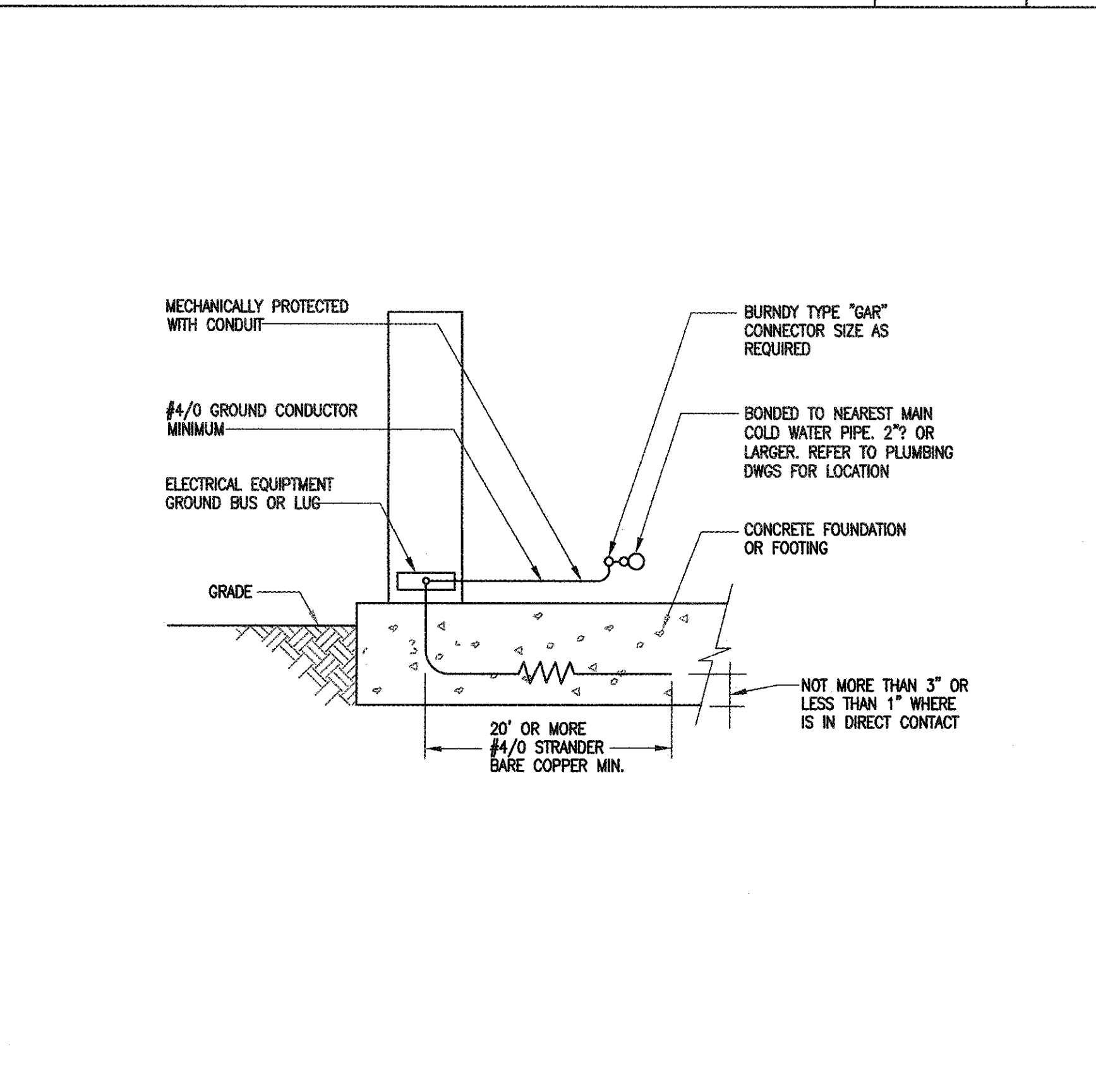

SWITCHBOARD GROUND N.T.S. 10

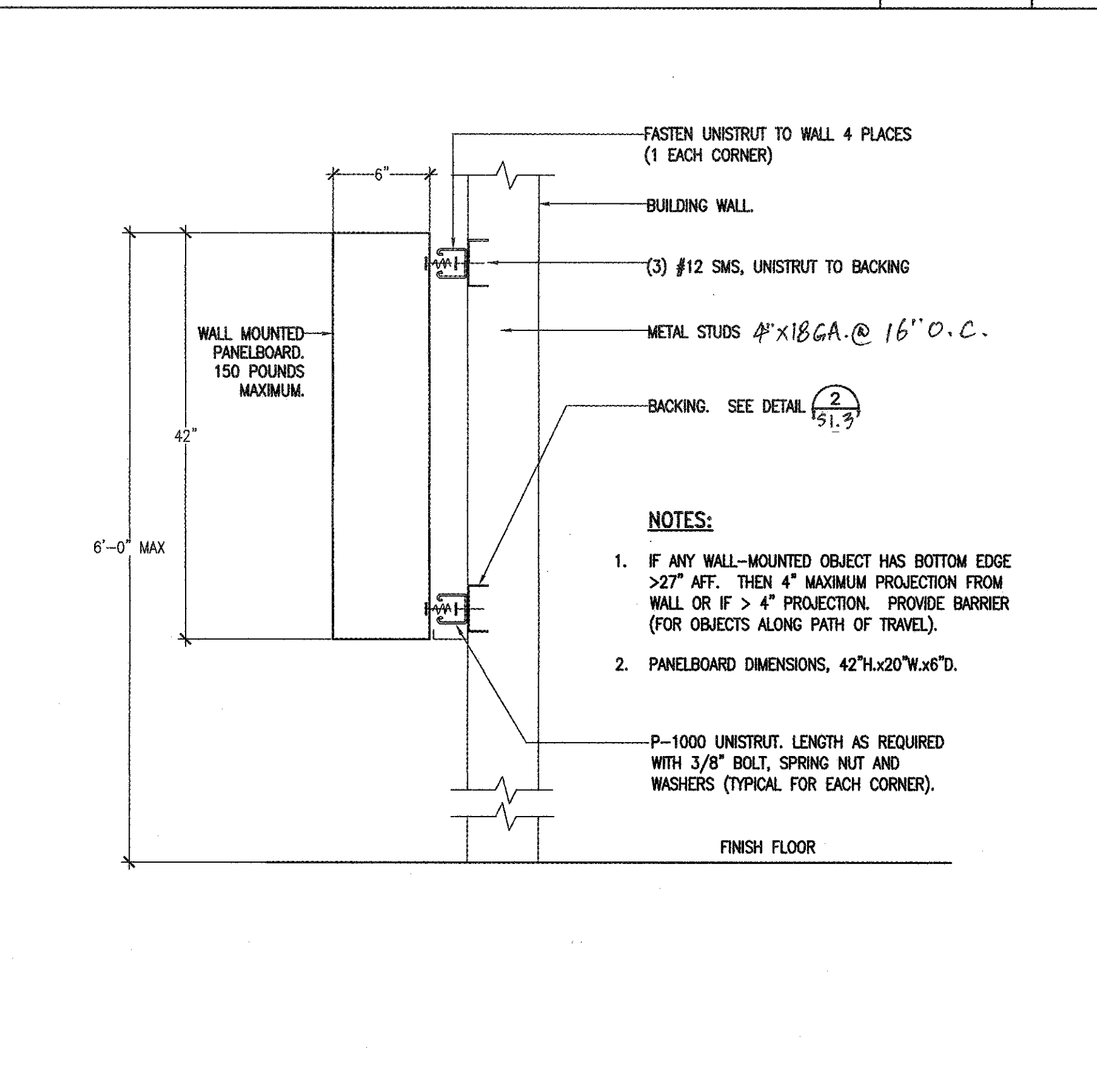

SURFACE MOUNTED PANEL DETAIL N.T.S. 11

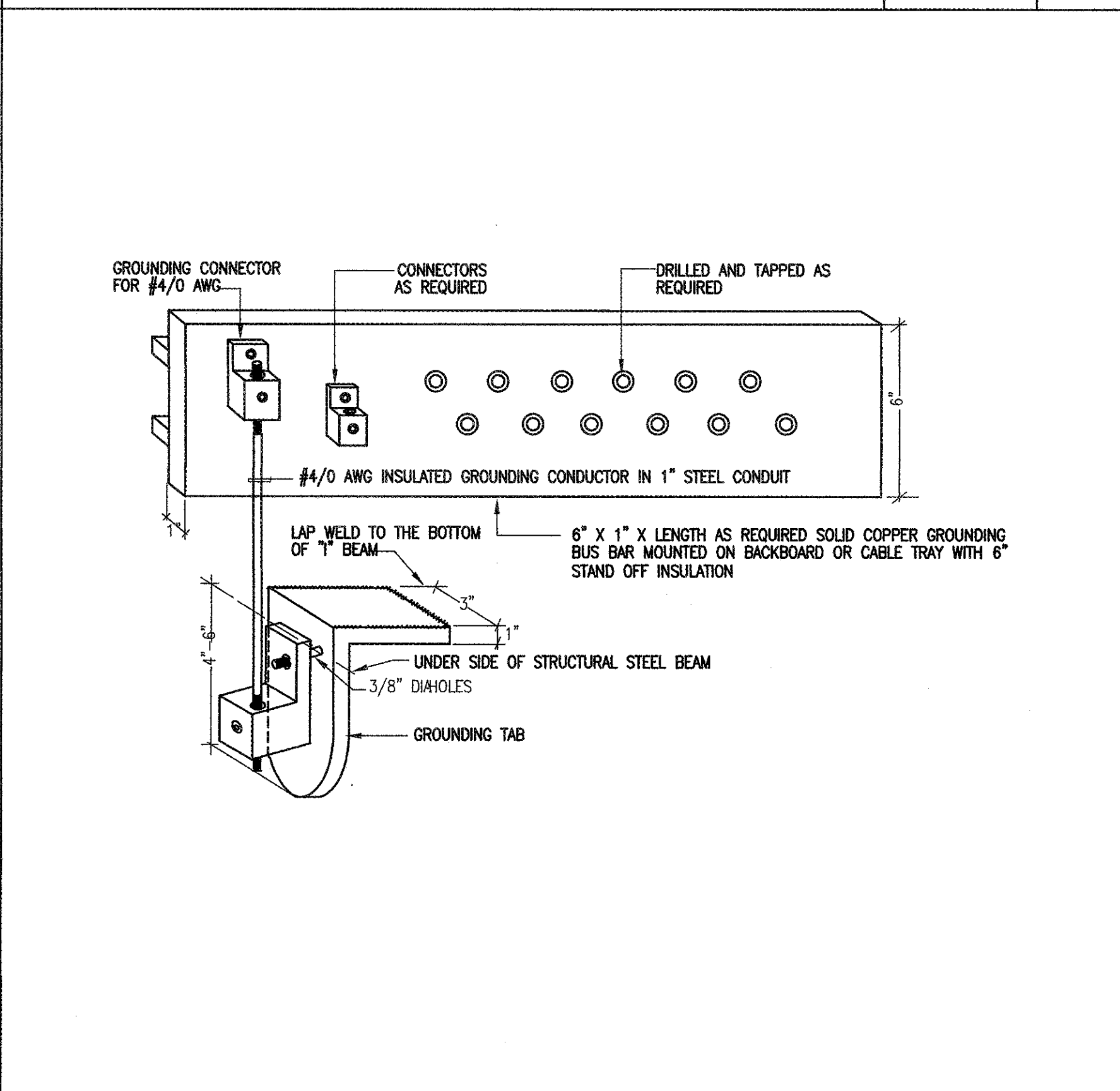

TYPICAL GROUNDING DETAIL N.T.S. 12

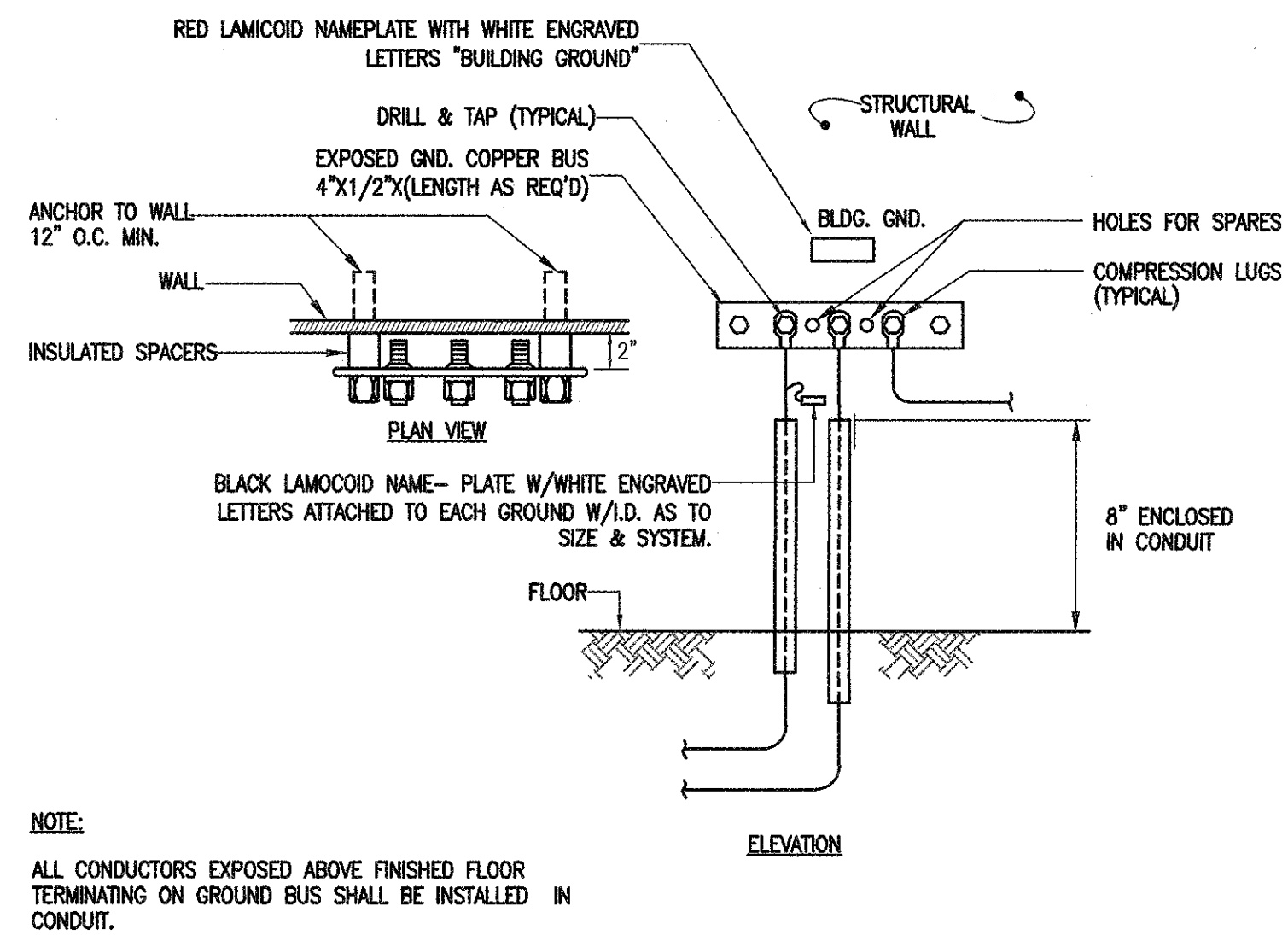

GROUNDING BUS BAR

N.T.S.

1

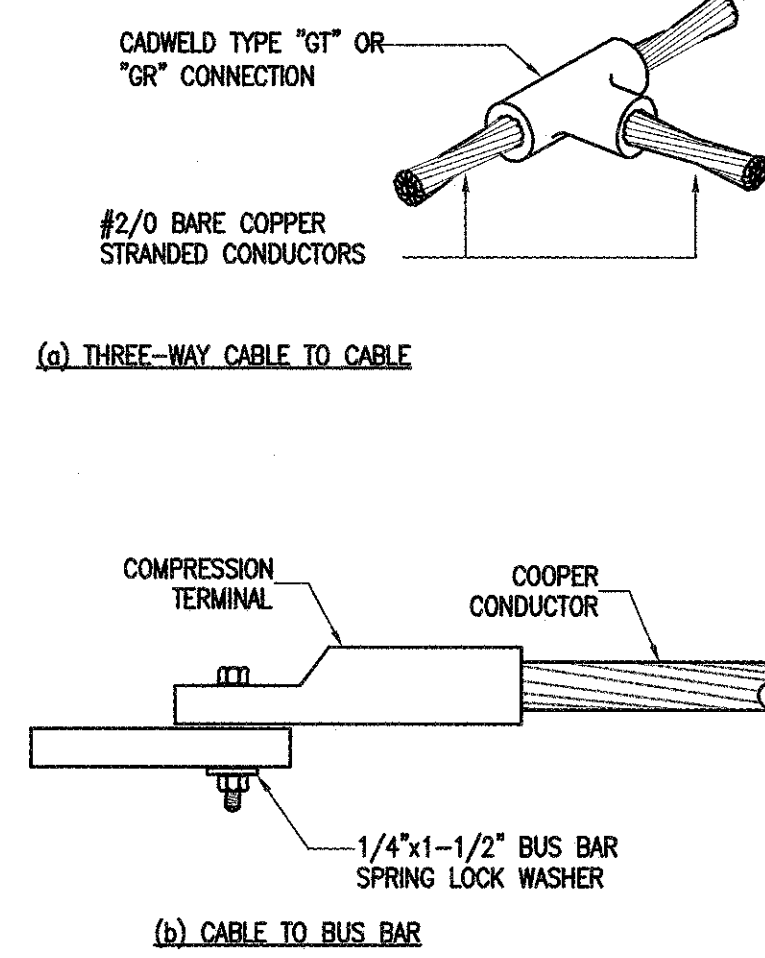

GROUND CONNECTORS

N.T.S.

2

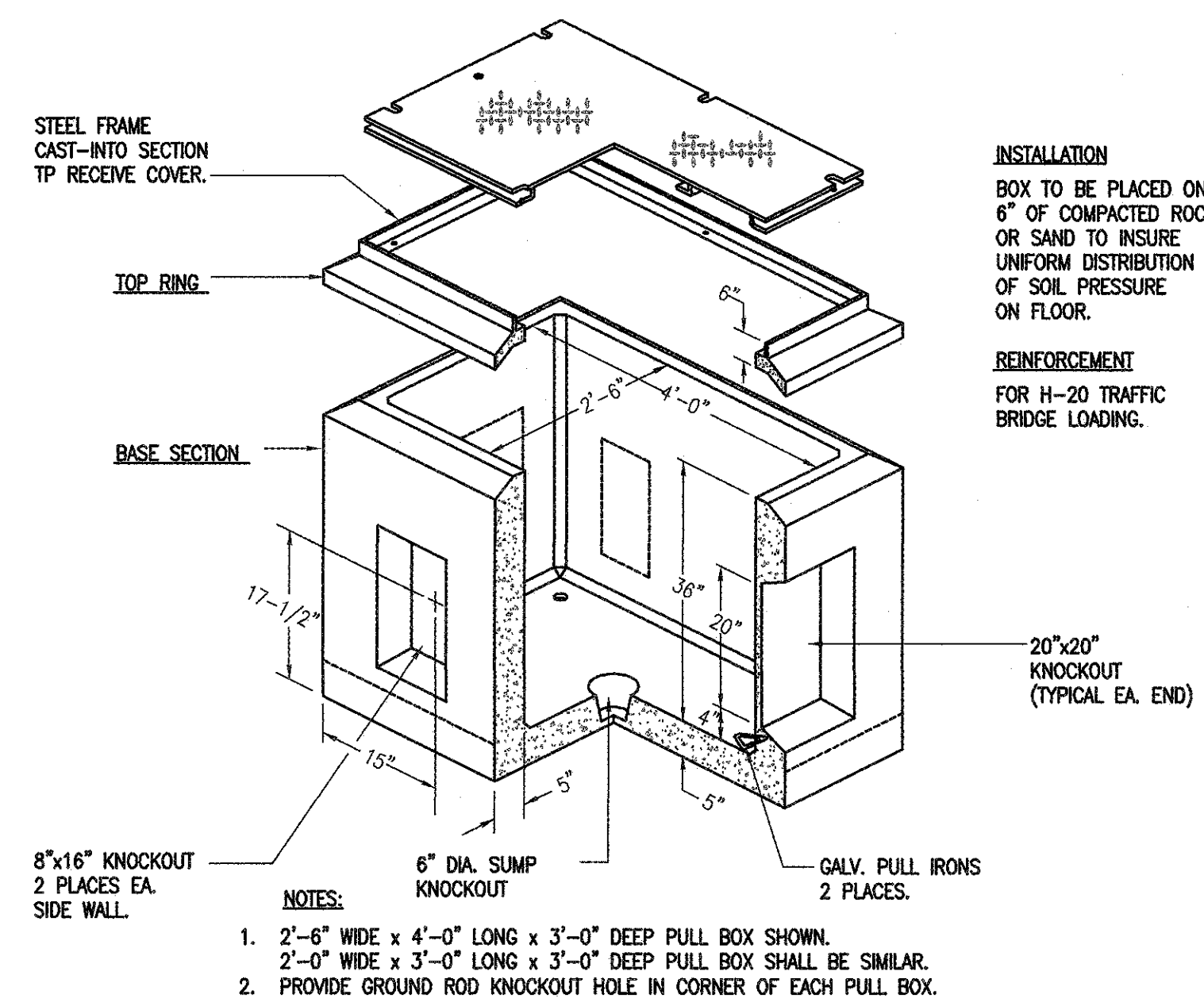

PRE-CAST CONCRETE PULL BOX DETAIL

N.T.S.

3

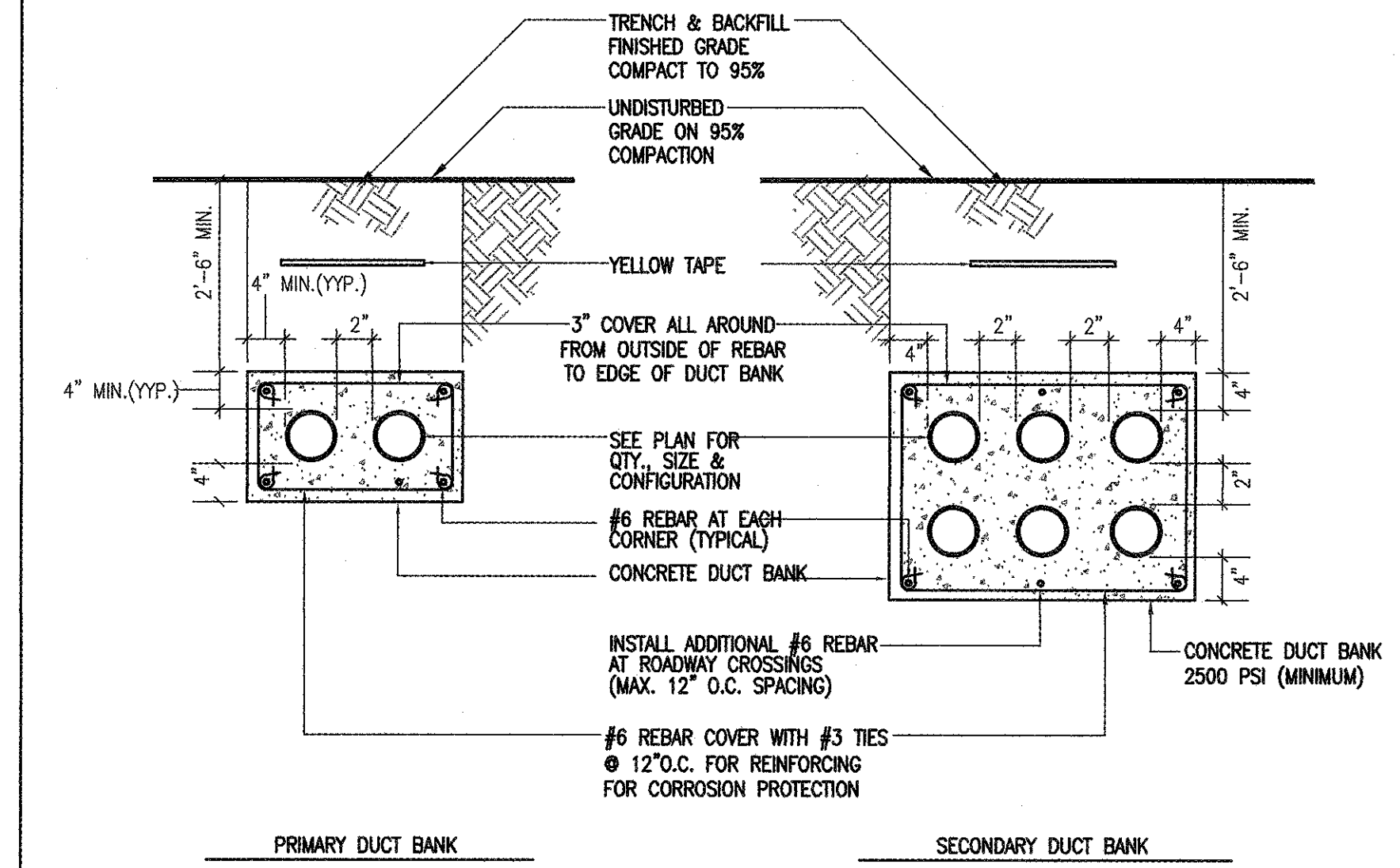

ELECTRICAL SERVICE DUCT BANK

N.T.S.

4

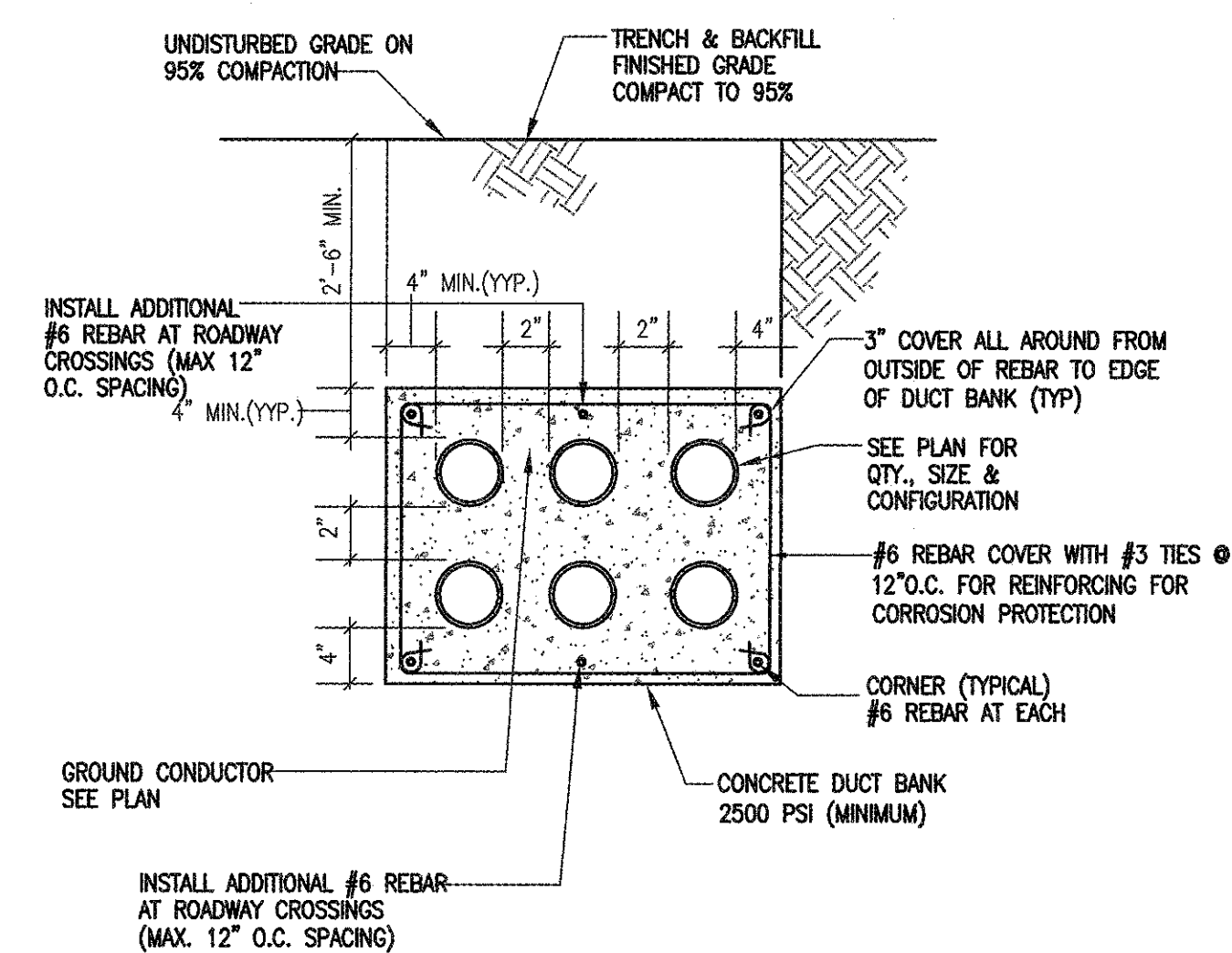

TYPICAL DUCT BANK SECTION

N.T.S.

5

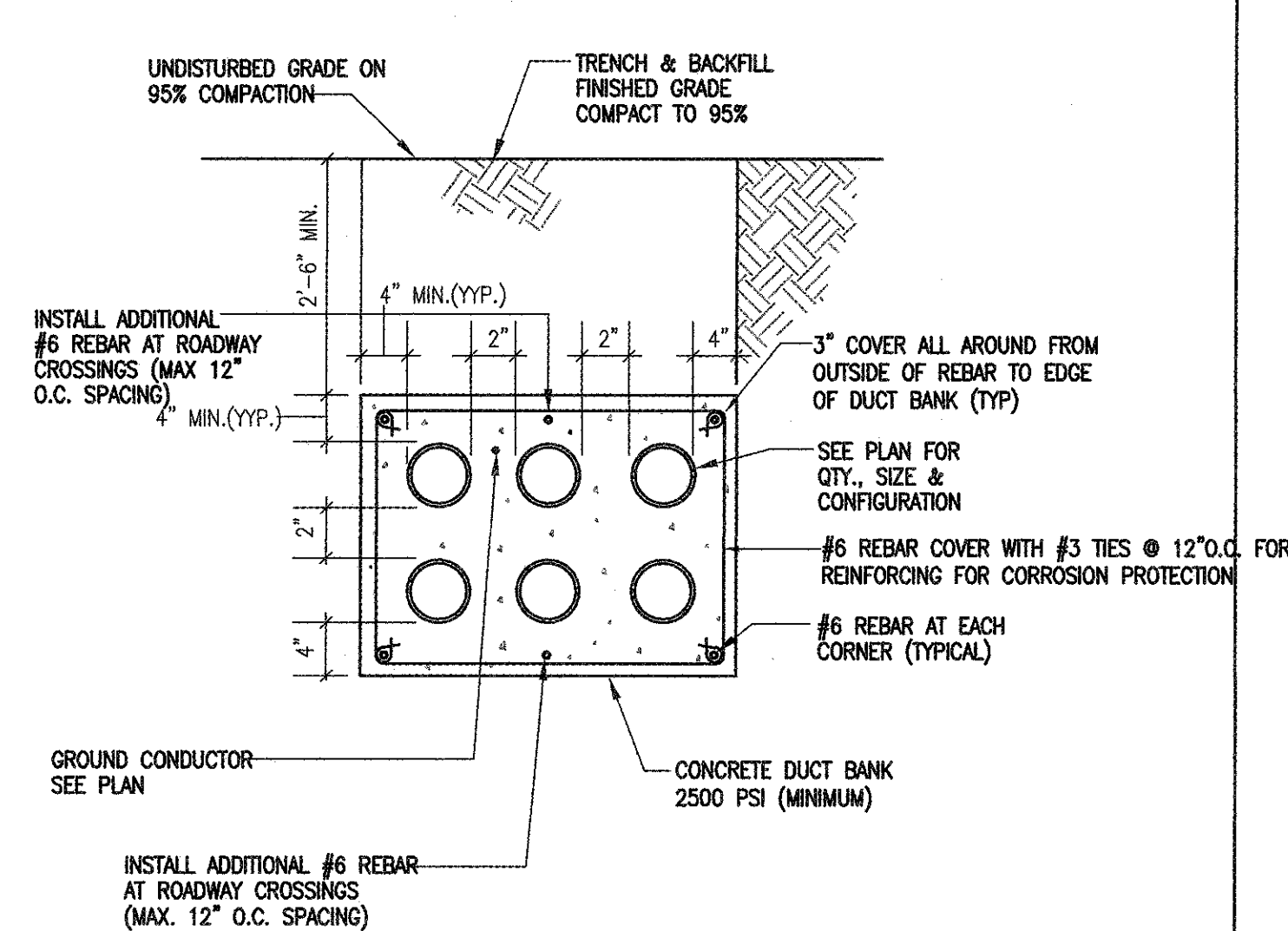

TYPICAL DUCT BANK SECTION

N.T.S.

6

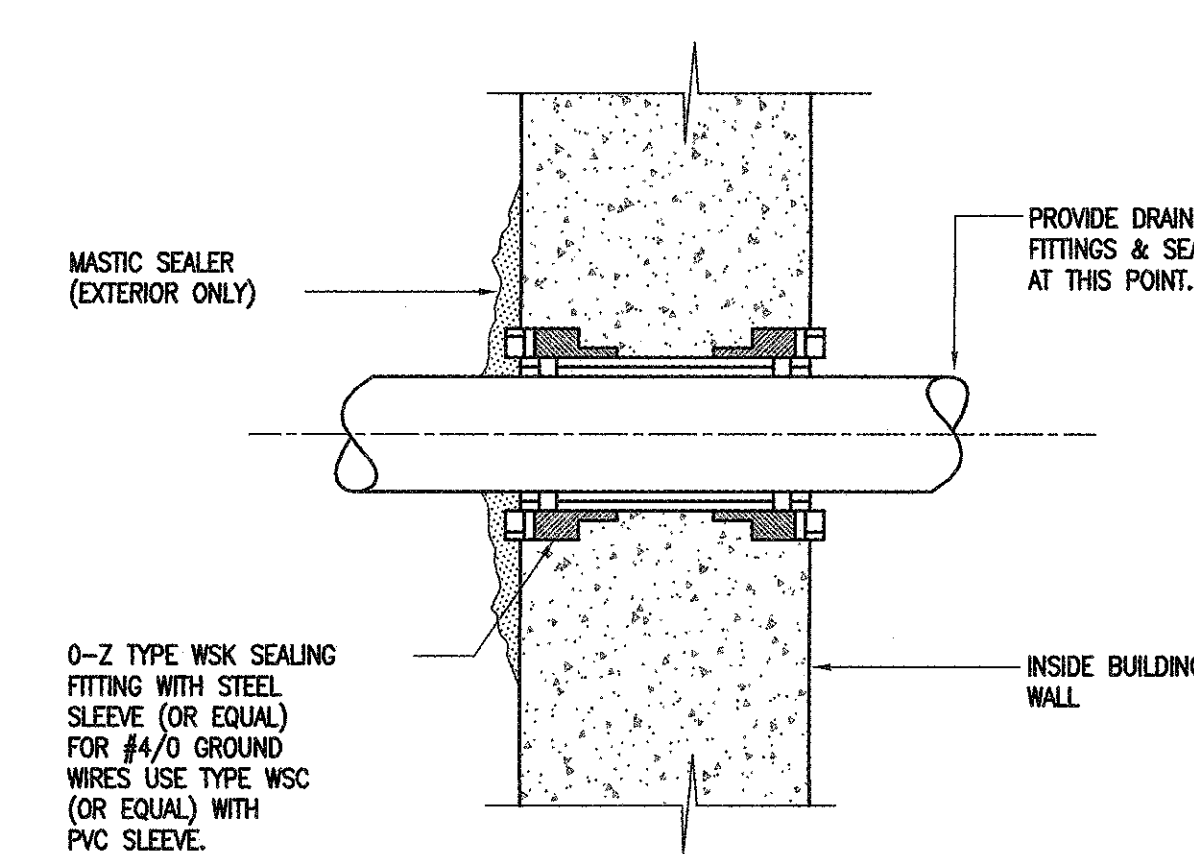

TYPICAL CONDUIT ENTRANCE BELOW GRADE

N.T.S.

7

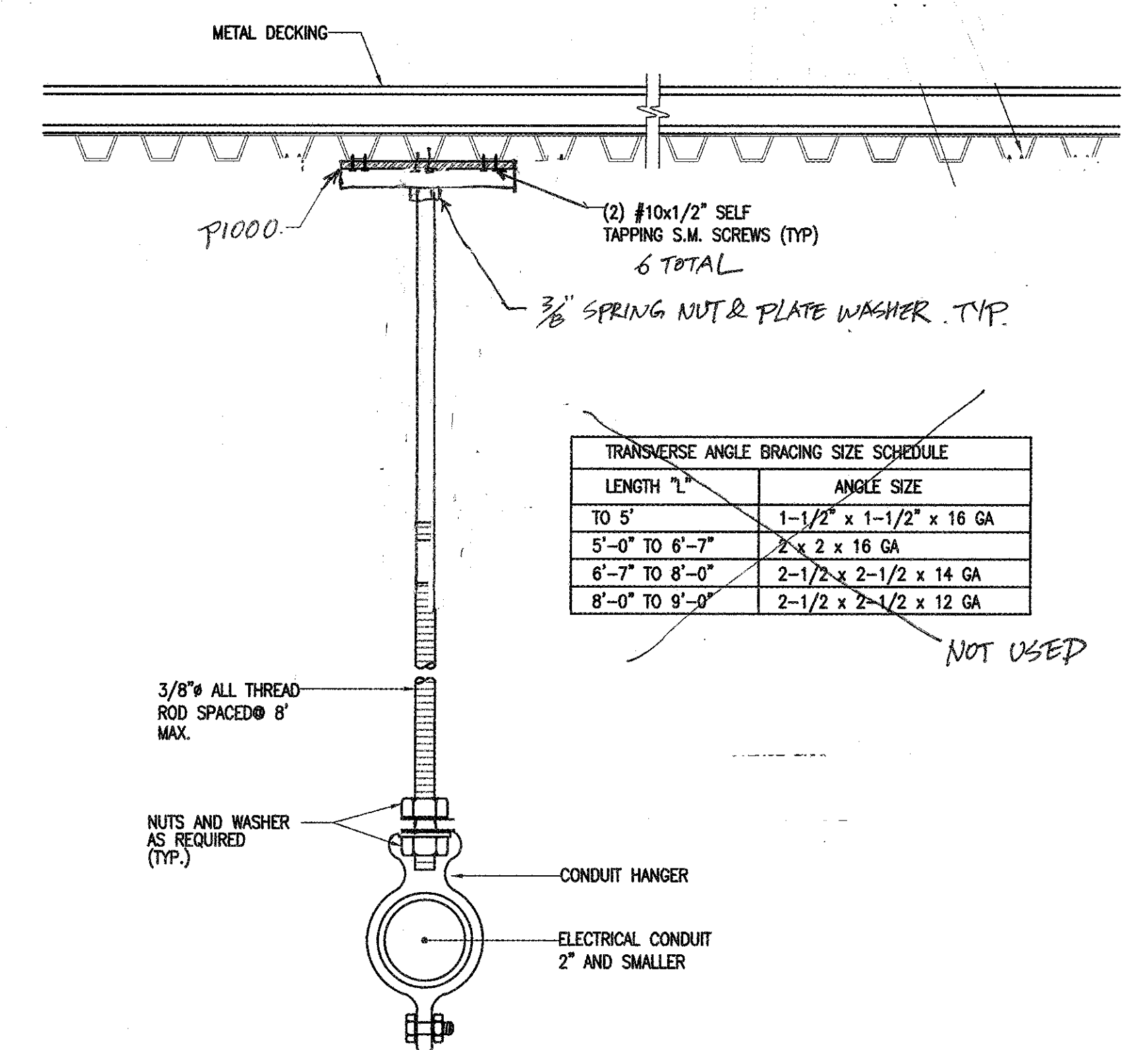

SINGLE CONDUIT SUPPORT DETAIL

N.T.S.

8

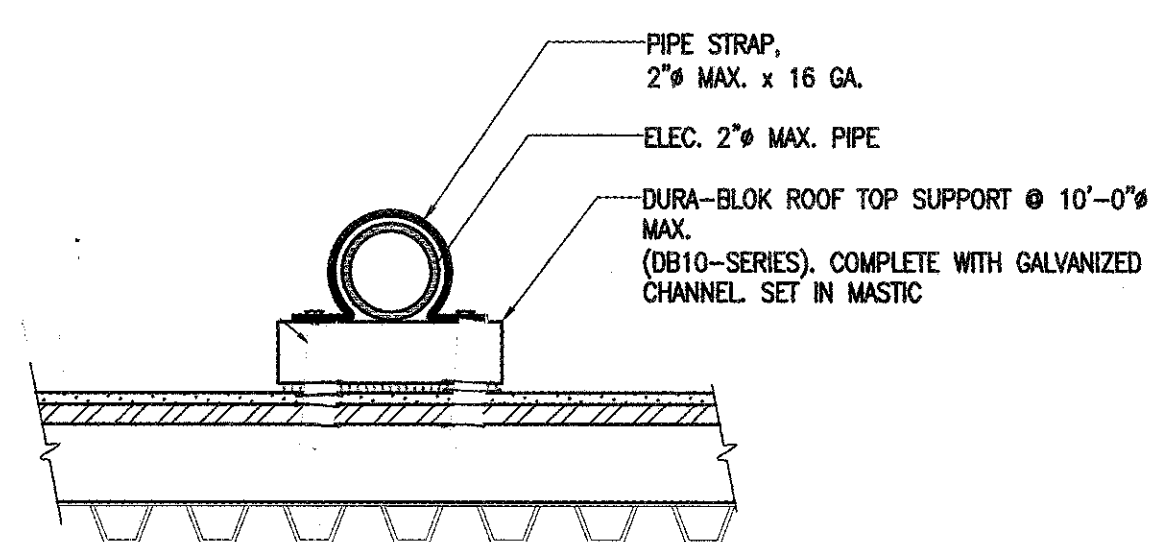

CONDUIT SUPPORT ON ROOF

N.T.S.

9

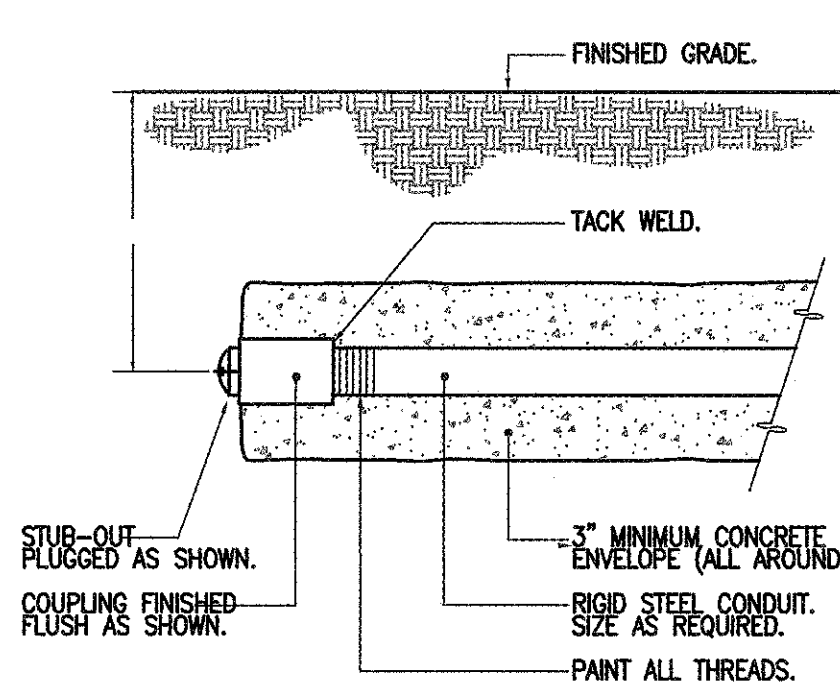

CONDUIT STUB-OUT DETAIL

N.T.S.

10

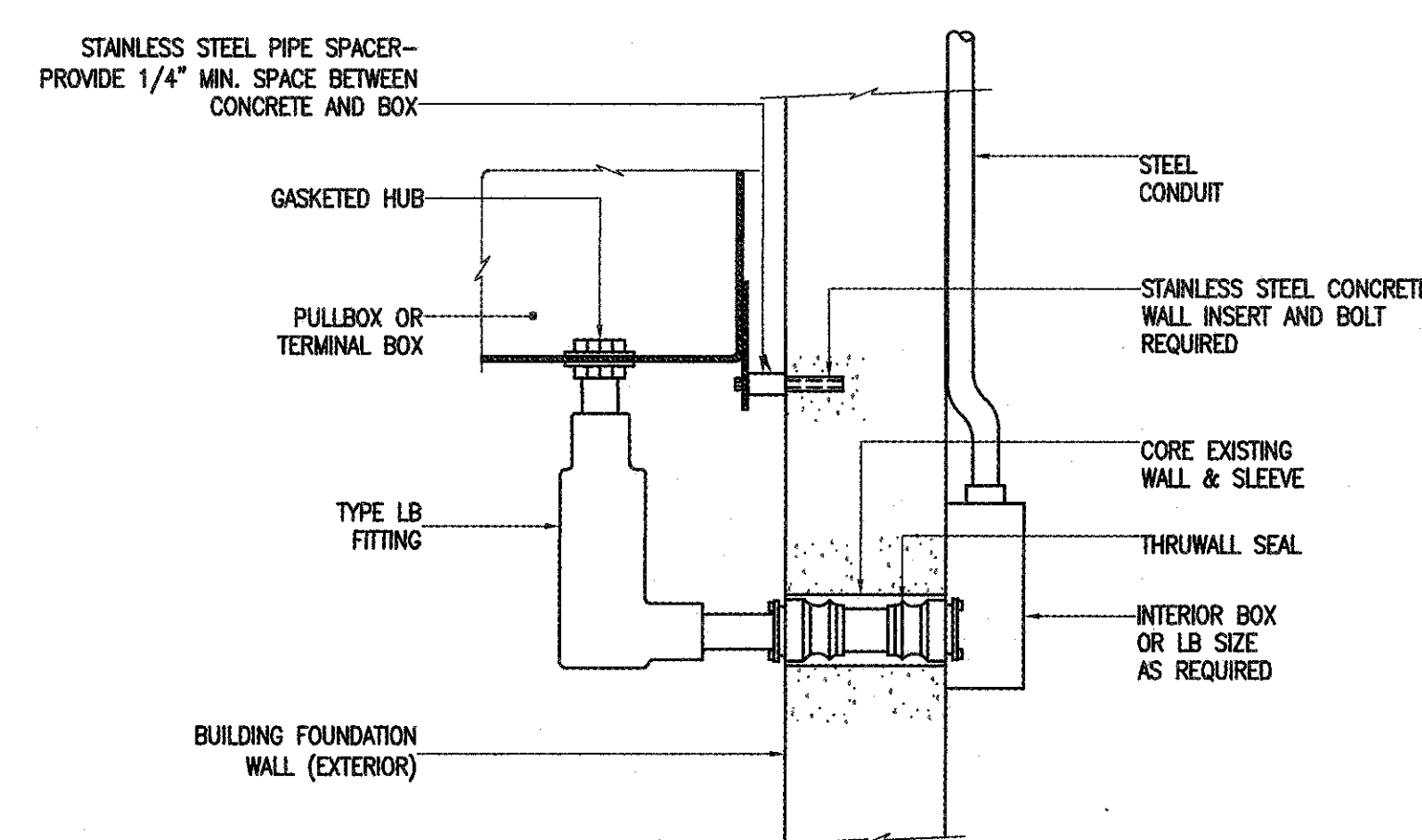

CONDUIT PENETRATION DETAIL

N.T.S.

11

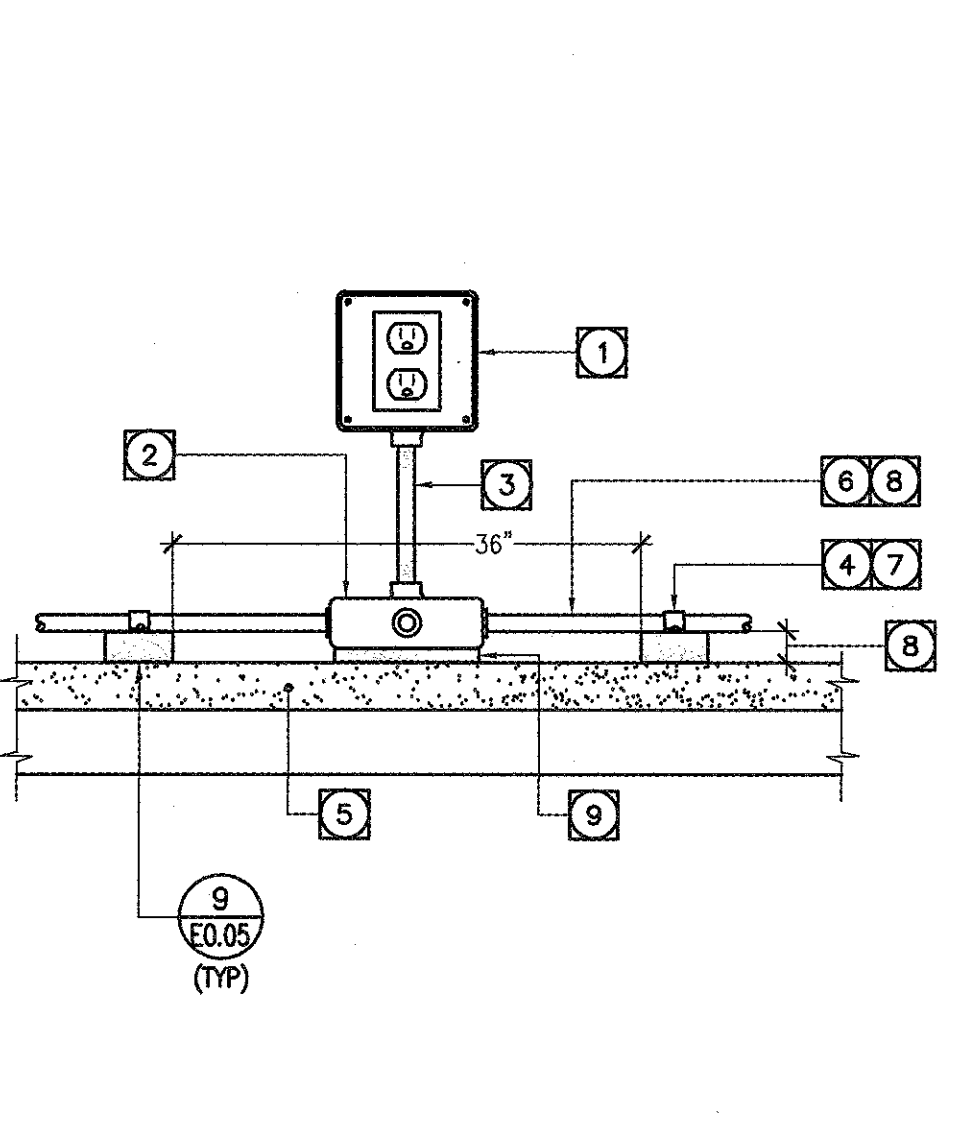
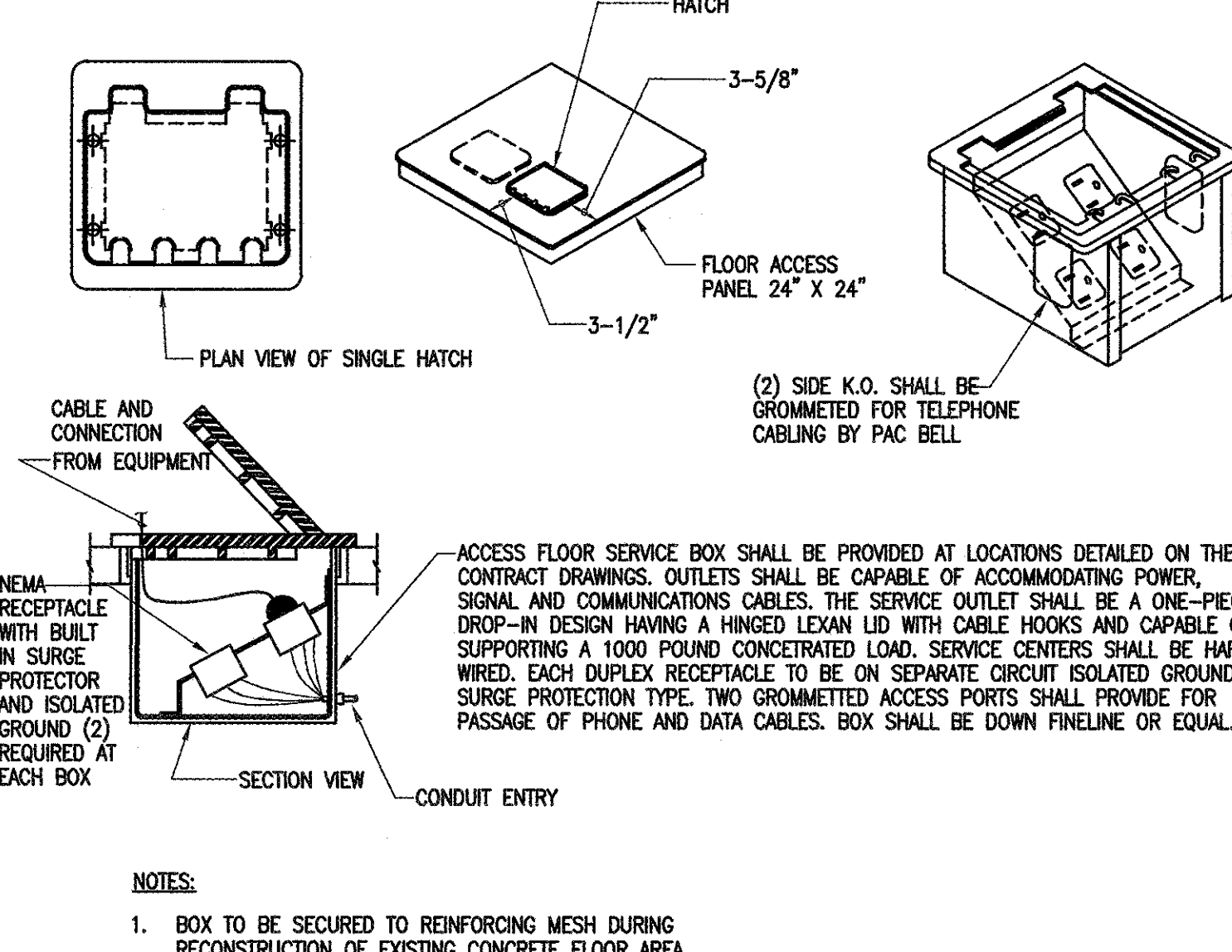
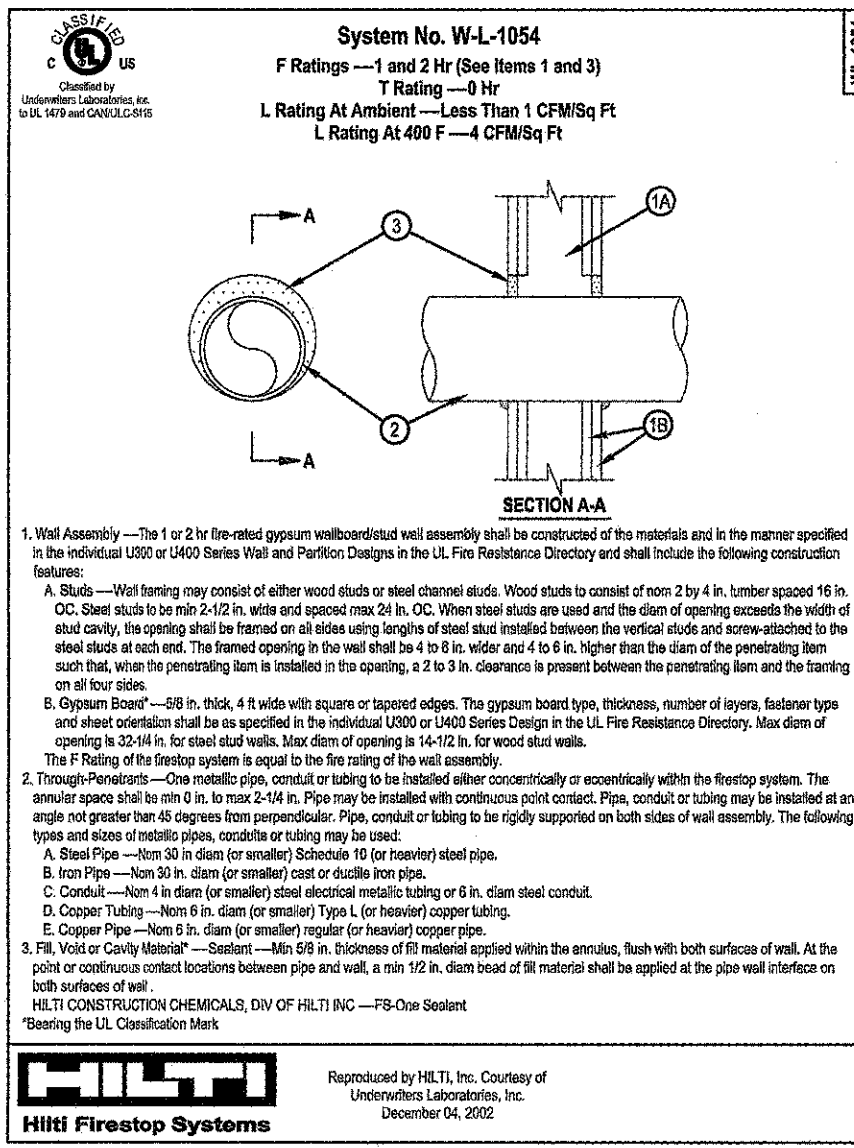

- REFERENCE NOTES:**
1. PROVIDE A 120V DUPLEX RECEPTACLE WITH GROUND FAULT INTERRUPTER. RECEPTACLE TO BE MOUNTED IN A CROUSE-HINDS "GRFX" SINGLE GANG BOX WITH SPRING DOOR COVER.
 2. PROVIDE A CROUSE-HINDS "GRFX" CAST STEEL BOX WITH "GRFX" GASKETED COVER. REFER TO DETAIL-9/E0.05 FOR DURA-BLOC SUPPORT. DO NOT ANCHOR CONDUITS AND/OR ASSOCIATED MATERIALS ON ROOF CONSTRUCTION.
 3. CONDUIT PEDESTAL. 8" LONG 3/4" RIGID GALVANIZED CONDUIT NIPPLE.
 4. HOMERUN CONDUIT.
 5. BUILT-UP ROOFING CONSTRUCTION.
 6. BRANCH CIRCUIT CONDUIT RUNNING ON ROOF.
 7. USE GALVANIZED RIGID STEEL OR IMC ONLY.
 8. MAINTAIN A MINIMUM OF 3" CLEARANCE OFF ROOF.
 9. DURABLE SUPPORT JUNCTION BOX. REFER TO DETAIL-9/E0.05

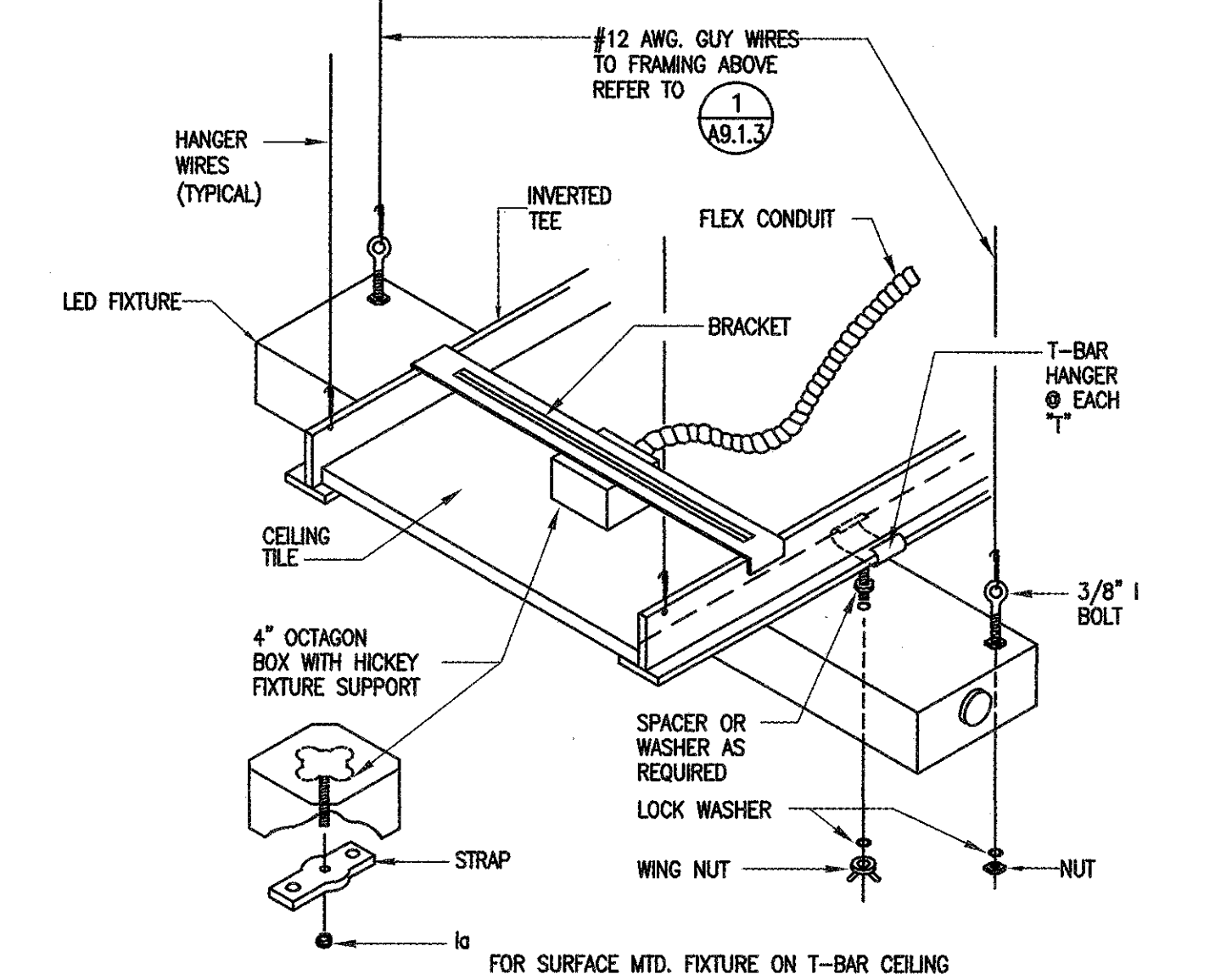

PENETRATION FIRESTOP FOR METAL CONDUIT N.T.S. 1 MEETING ROOM FLOOR POCKET N.T.S. 2 ROOF RECEPTACLE N.T.S. 3 SURFACE FIXTURE SUPPORT N.T.S. 4

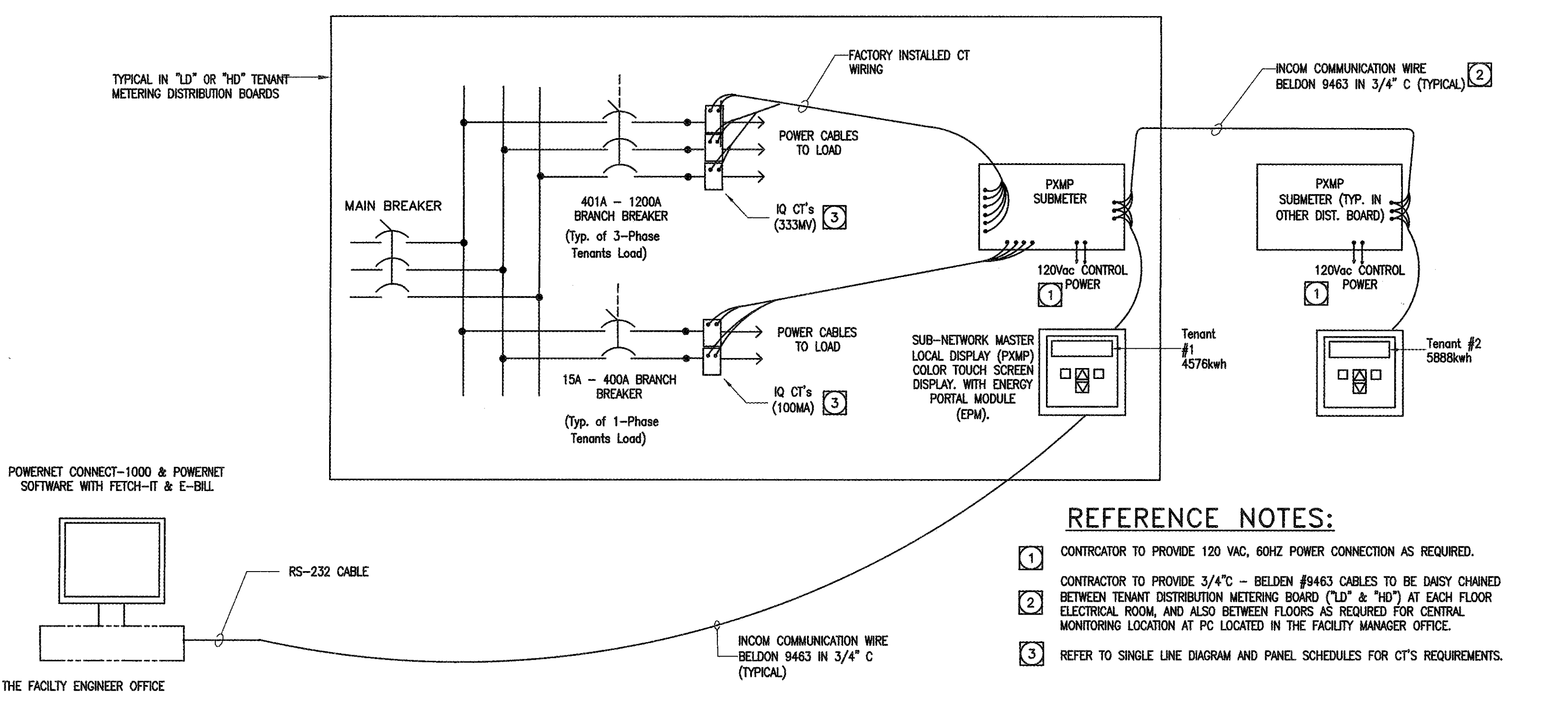

- REFERENCE NOTES:**
1. CONTRACTOR TO PROVIDE 120 VAC, 60HZ POWER CONNECTION AS REQUIRED.
 2. CONTRACTOR TO PROVIDE 3/4" - BELDEN #9463 CABLES TO BE DAILY CHANGED BETWEEN TENANT DISTRIBUTION METERING BOARD ("LD" & "HD") AT EACH FLOOR ELECTRICAL ROOM, AND ALSO BETWEEN FLOORS AS REQUIRED FOR CENTRAL MONITORING LOCATION AT PC LOCATED IN THE FACILITY MANAGER OFFICE.
 3. REFER TO SINGLE LINE DIAGRAM AND PANEL SCHEDULES FOR CT'S REQUIREMENTS.

TYPICAL DISTRIBUTION BOARDS TENANT METERING COMMUNICATION WIRING DIAGRAM N.T.S. 5 FIXTURE SUPPORT DETAIL N.T.S. 6 POLE BASE DETAIL N.T.S. 7

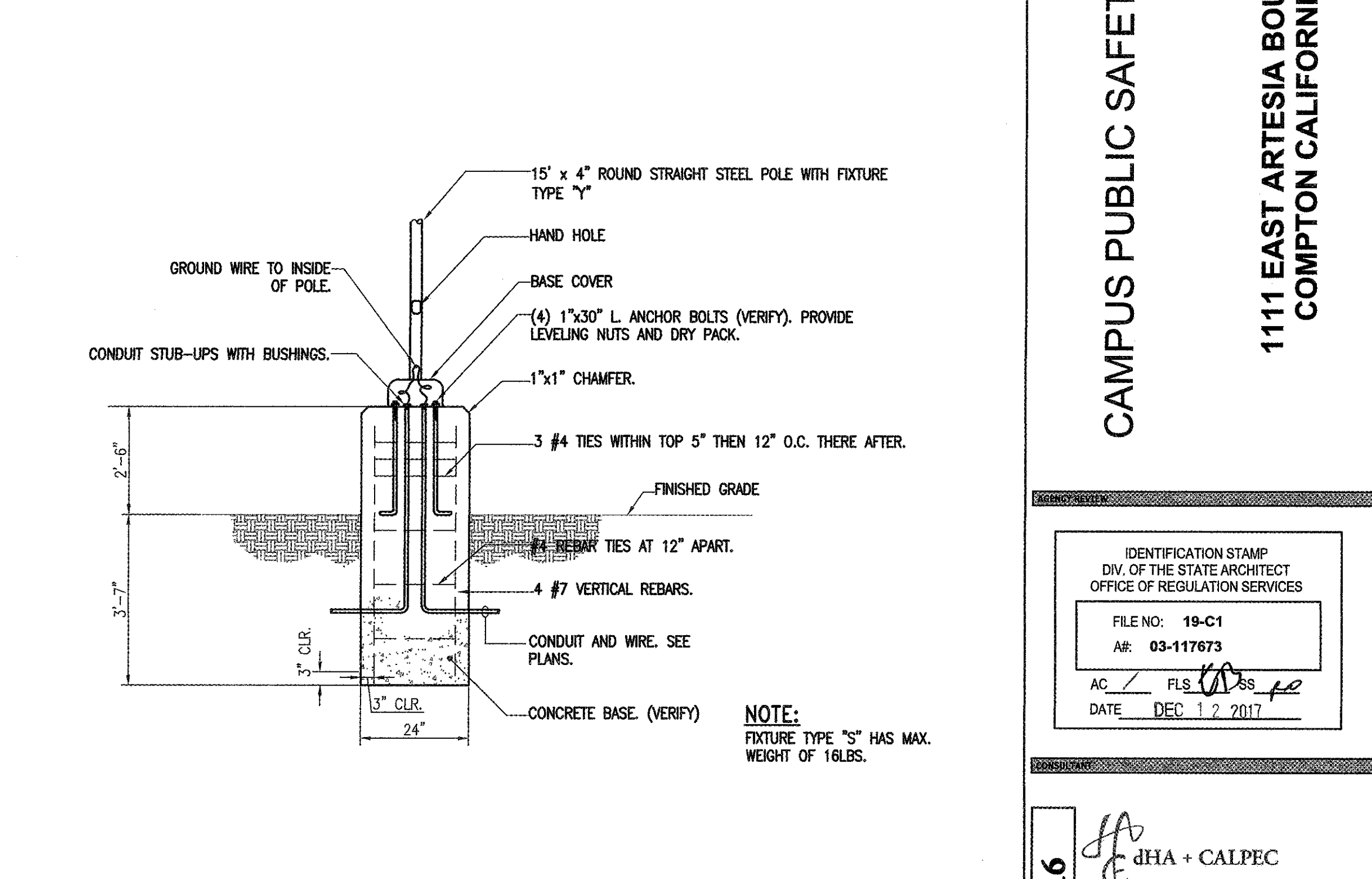
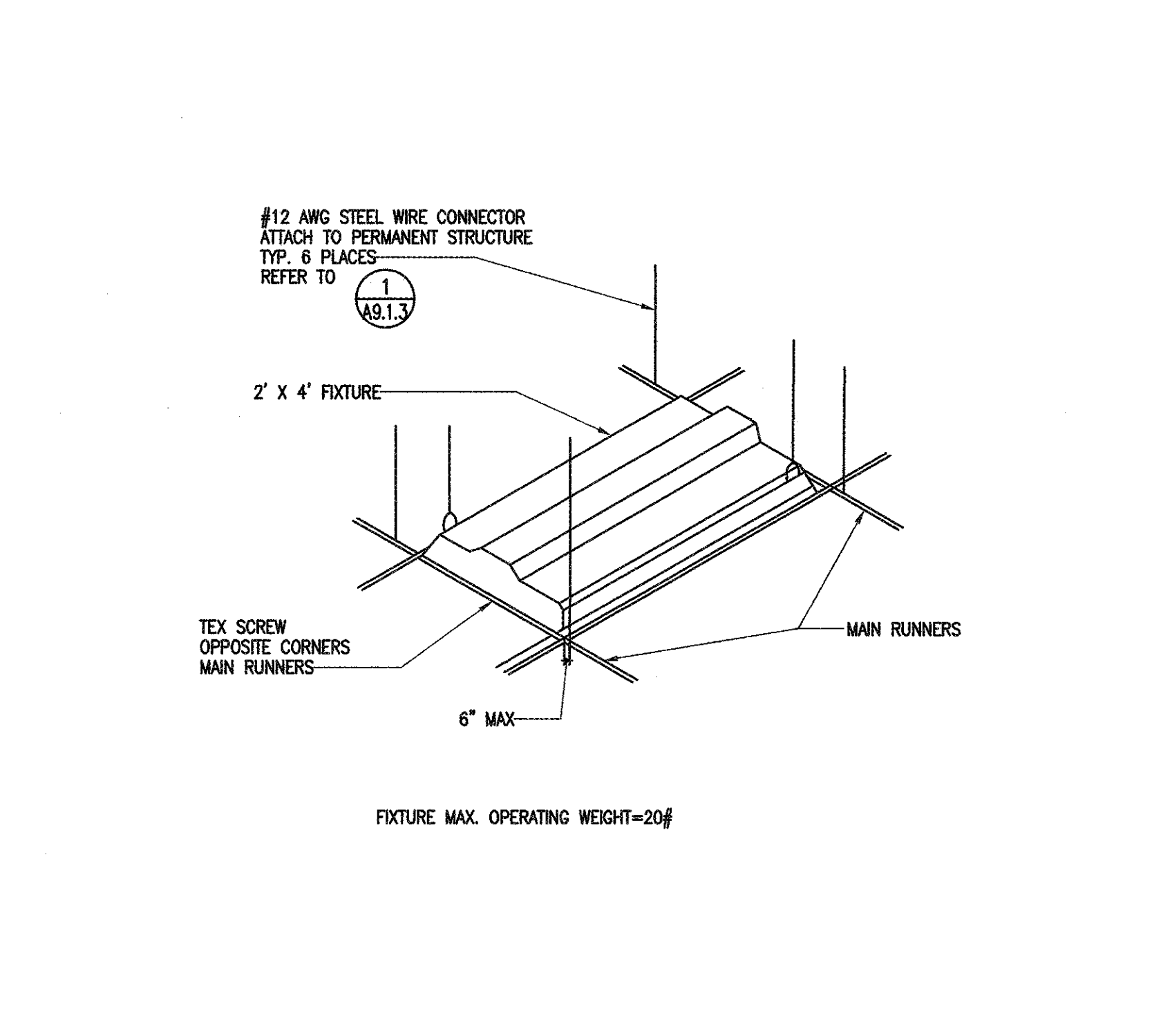

TYPICAL DISTRIBUTION BOARDS TENANT METERING COMMUNICATION WIRING DIAGRAM N.T.S. 5

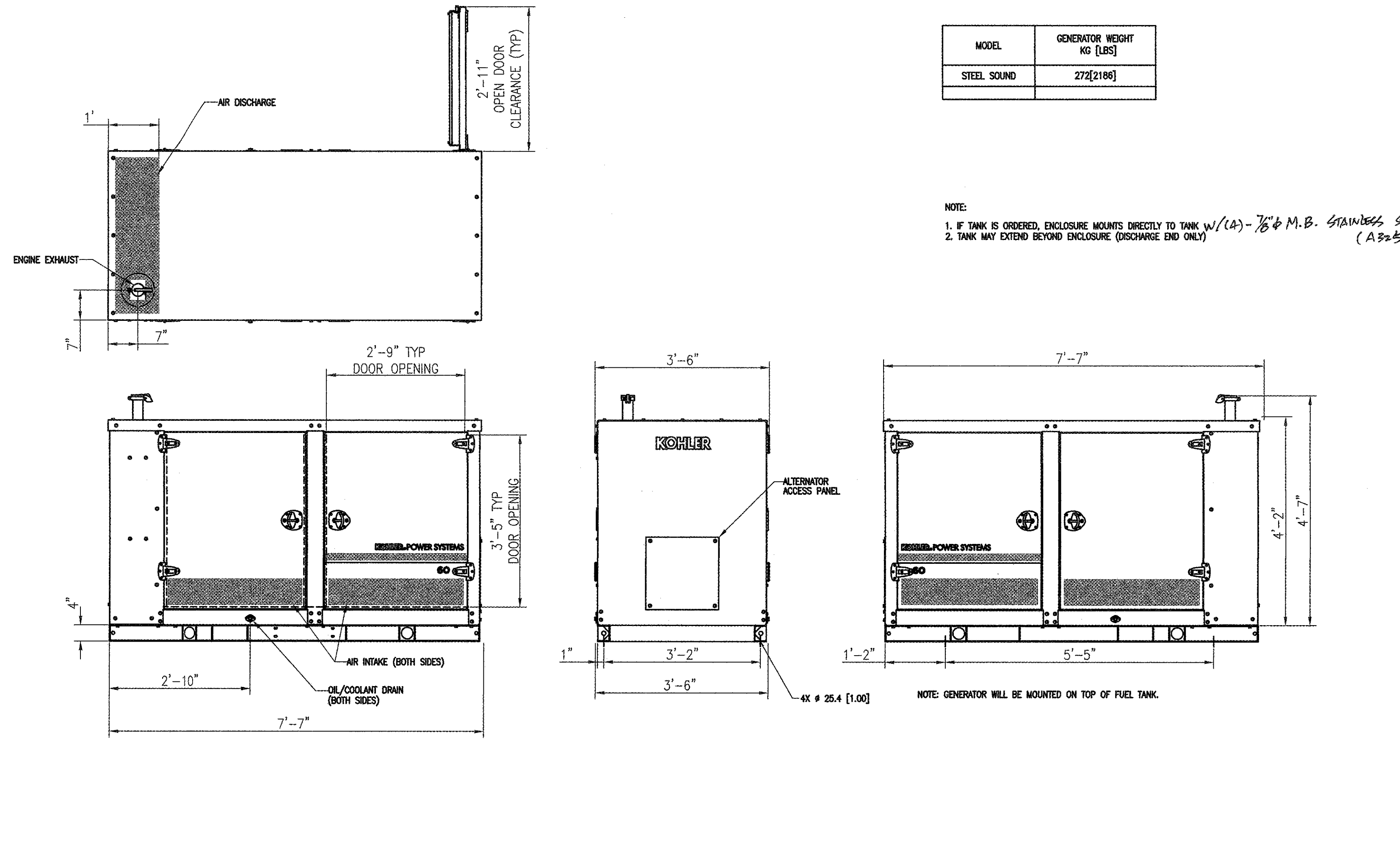

FIXTURE SUPPORT DETAIL N.T.S. 6 POLE BASE DETAIL N.T.S. 7

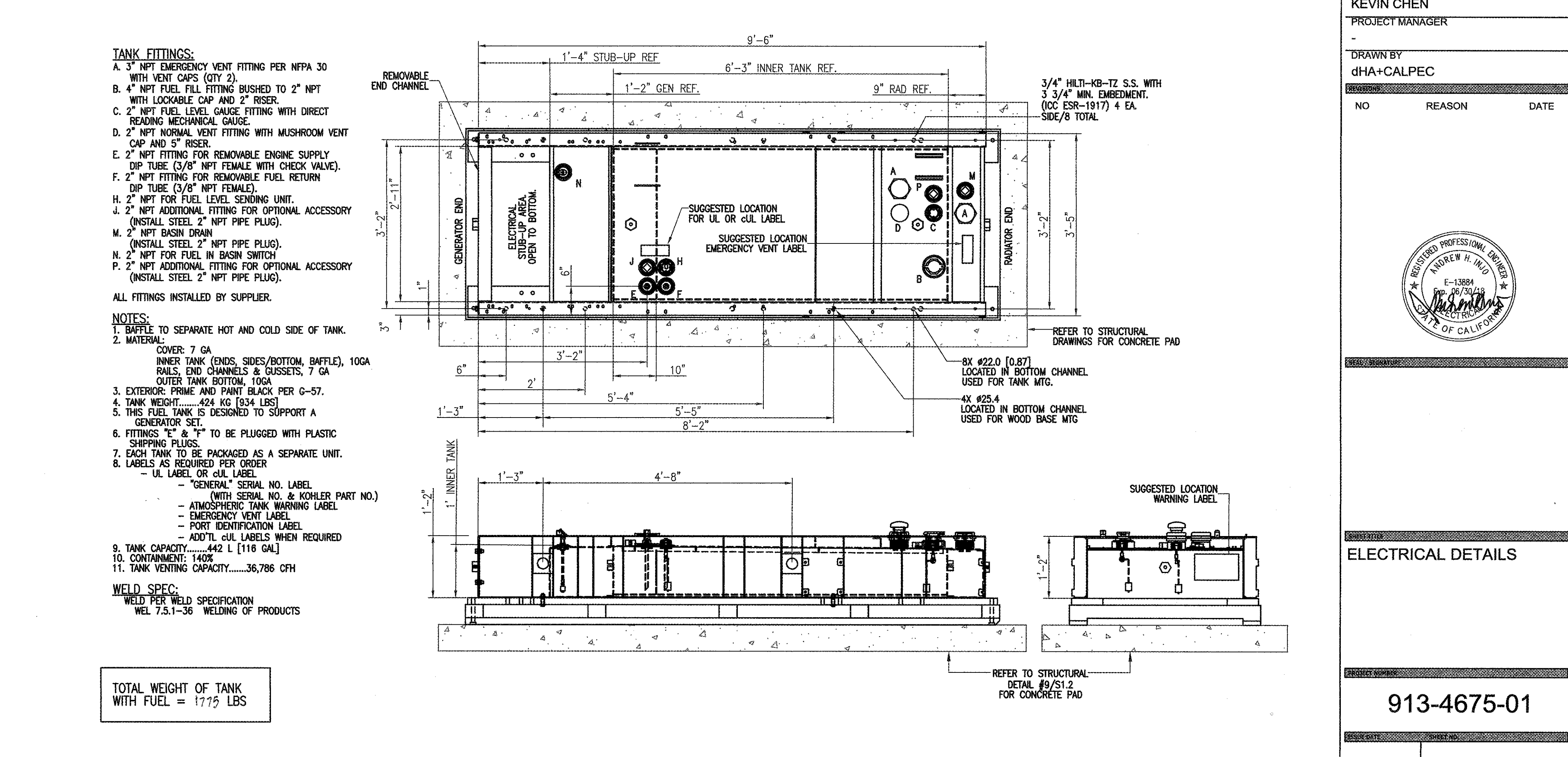

EMERGENCY GENERATOR DETAIL N.T.S. 8 FUEL TANK DETAIL N.T.S. 9

LITTLE
 DIVERSIFIED ARCHITECTURAL CONSULTING

1300 Dove Street, Suite 100
 Newport Beach, CA 92660
 T: 949.698.1400 F: 949.698.1483
 www.littleonline.com

This drawing and the design shown are the property of Little Diverisified Architectural Consulting. The reproduction, copying or other use of this drawing without their written consent is prohibited and any infringement will be subject to legal action.

© Little 2016

COMPTON CCD

CAMPUS PUBLIC SAFETY BUILDING

1111 EAST ARTESIA BOULEVARD,
 COMPTON CALIFORNIA 90221

IDENTIFICATION STAMP
 DIV. OF THE STATE ARCHITECT
 OFFICE OF REGULATION SERVICES

FILE NO: 19-C1
 AR: 03-117673
 AC: FLS
 DATE: DEC 12 2017

16516
 JHA + CALPEC

180 S. ARROYO PARKWAY
 SUITE 100, 100
 PASADENA, CA 91106
 TEL: (626) 446-8680
 FAX: (626) 446-8081

PRINCIPAL IN CHARGE
 KEVIN CHEN
 PROJECT MANAGER

DRAWN BY
 JHA+CALPEC

NO REASON DATE

REGISTERED PROFESSIONAL ENGINEER
 KEVIN CHEN
 E-13894
 CIVIL ENGINEER
 STATE OF CALIFORNIA

ELECTRICAL DETAILS

913-4675-01

11/21/2017 E0.0.6

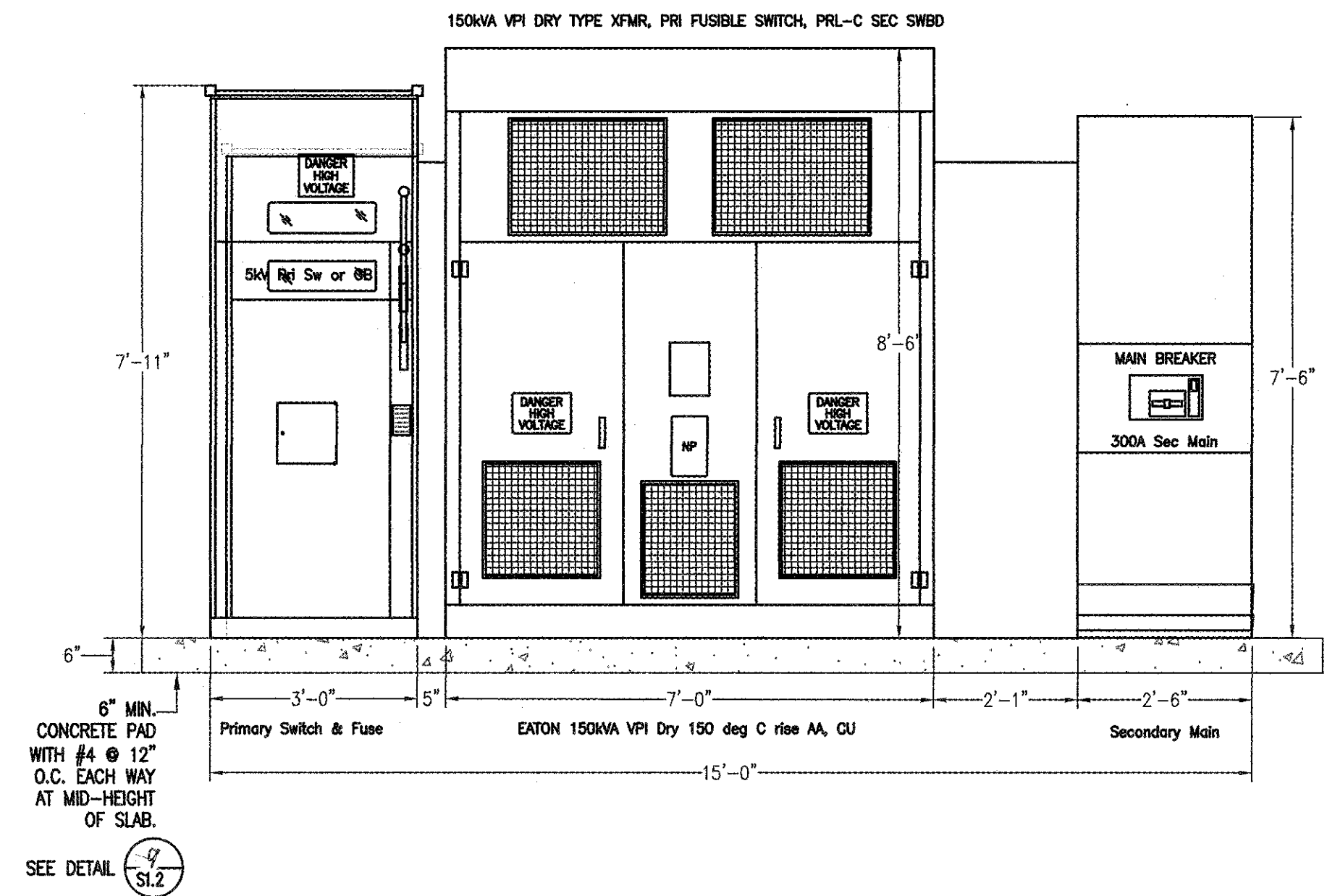

SUB STATION ELEVATION DETAIL

N.T.S. 1

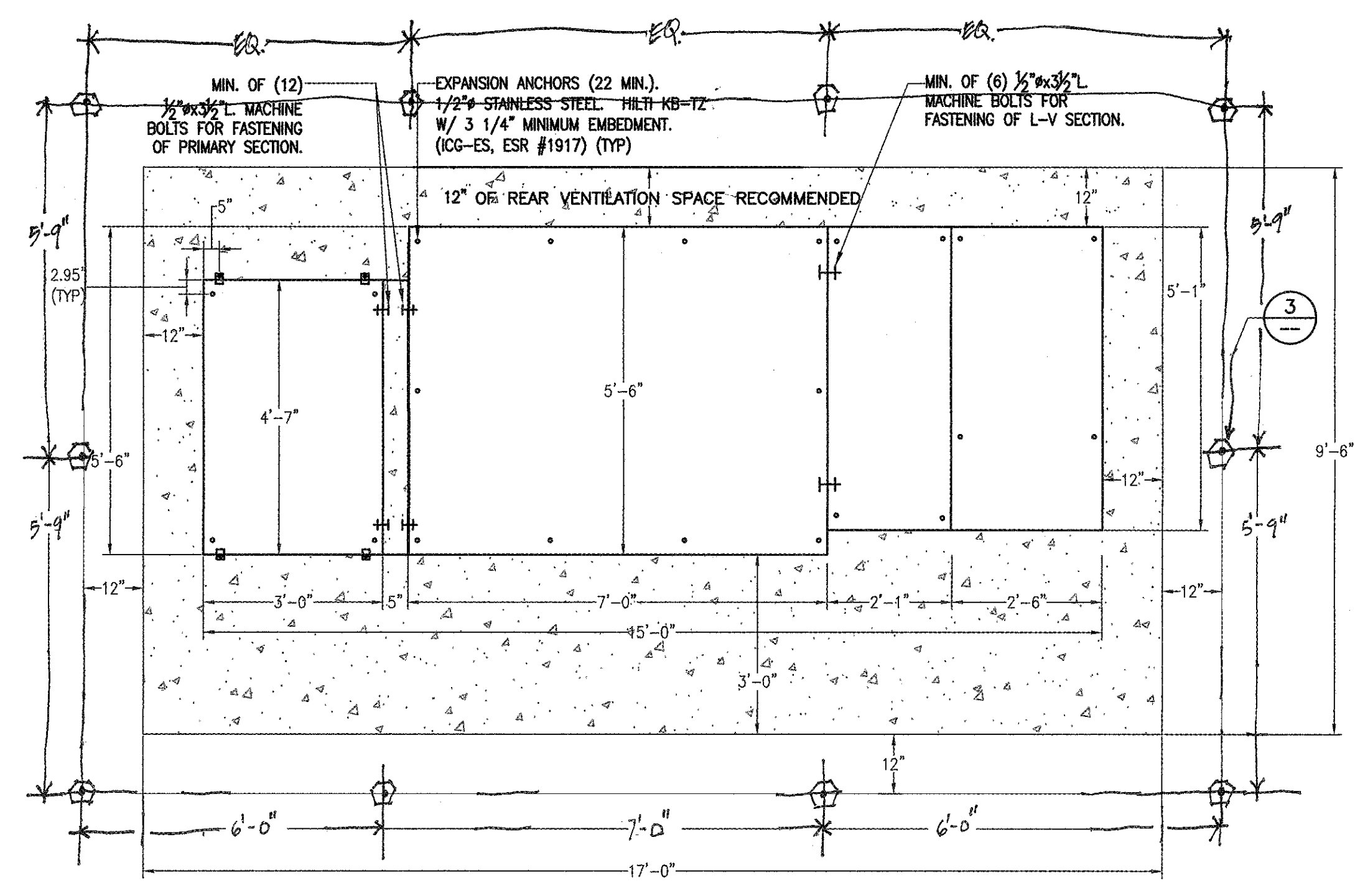

SUB STATION ANCHORING DETAIL

N.T.S. 2

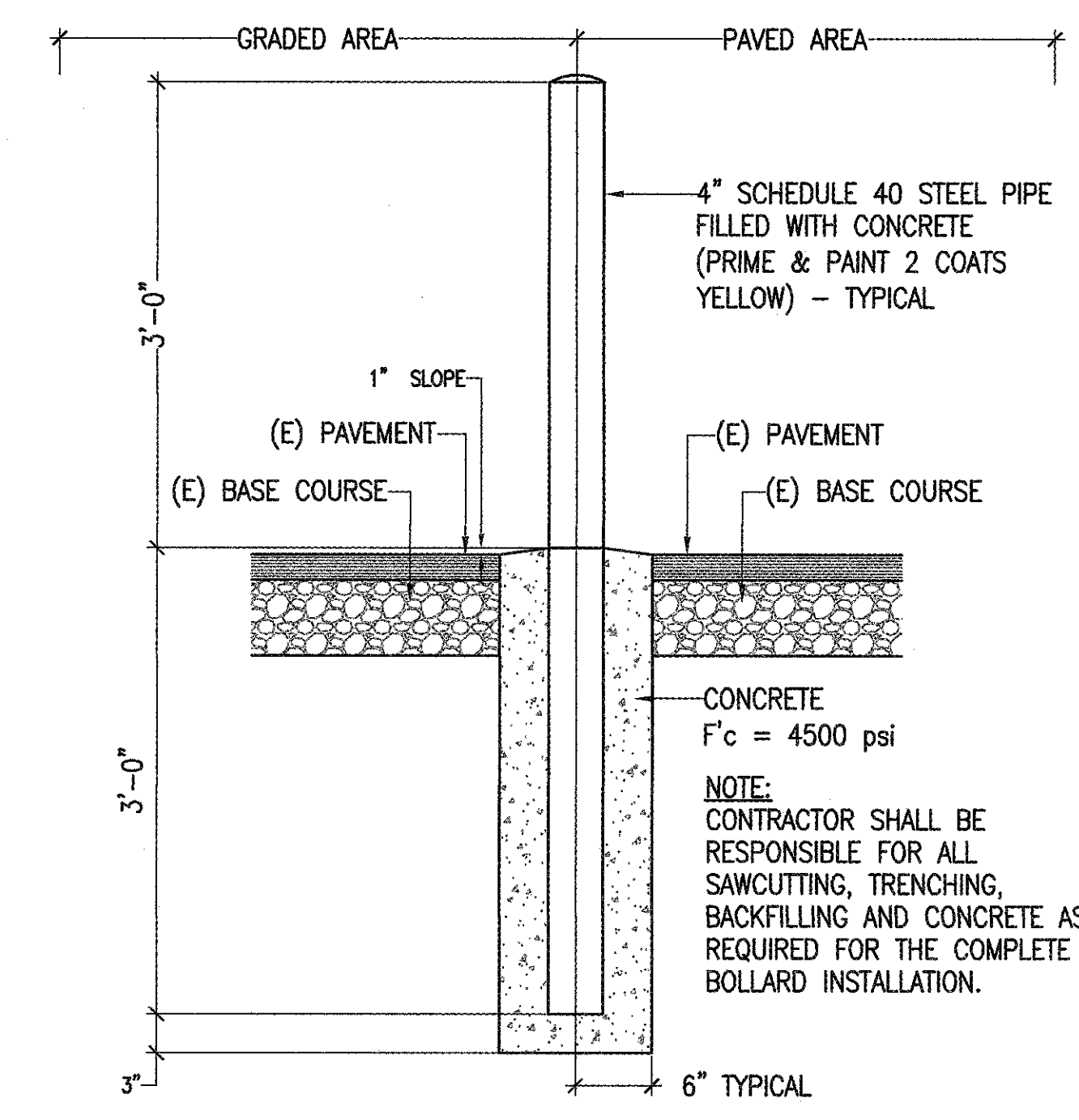

BOLLARD DETAIL

N.T.S. 3

N.T.S. 4

N.T.S. 5

N.T.S. 6

N.T.S. 7

N.T.S. 8

N.T.S. 9

LITTLE
DIVERSIFIED ARCHITECTURAL CONSULTING

1300 Dove Street, Suite 100
Newport Beach, CA 92660
T: 949.698.1400 F: 949.698.1433
www.littleonline.com

This drawing and the design shown are the property of Little Diversified Architectural Consulting. The reproduction, copying or other use of this drawing without their written consent is prohibited and any infringement will be subject to legal action.

© Little 2016

**COMPTON
CCD**

CAMPUS PUBLIC SAFETY BUILDING

**1111 EAST ARTESIA BOULEVARD,
COMPTON CALIFORNIA 90221**

IDENTIFICATION STAMP
DIV. OF THE STATE ARCHITECT
OFFICE OF REGULATION SERVICES

FILE NO. 19-C1
AP. 03-117673

AC / FLS / JBS / JS
DATE DEC 12 2017

16516 dHA + CALPEC

150 S. ARROYO PARKWAY
SUITE NO. 100
PASADENA, CA 91105
TEL: (626) 446-8880
FAX: (626) 446-8881

PRINCIPAL IN CHARGE
KEVIN CHEN

PROJECT MANAGER

DRAWN BY
dHA+CALPEC

NO REASON DATE

ELECTRICAL DETAILS

913-4675-01

11/21/2017 E0.0.7

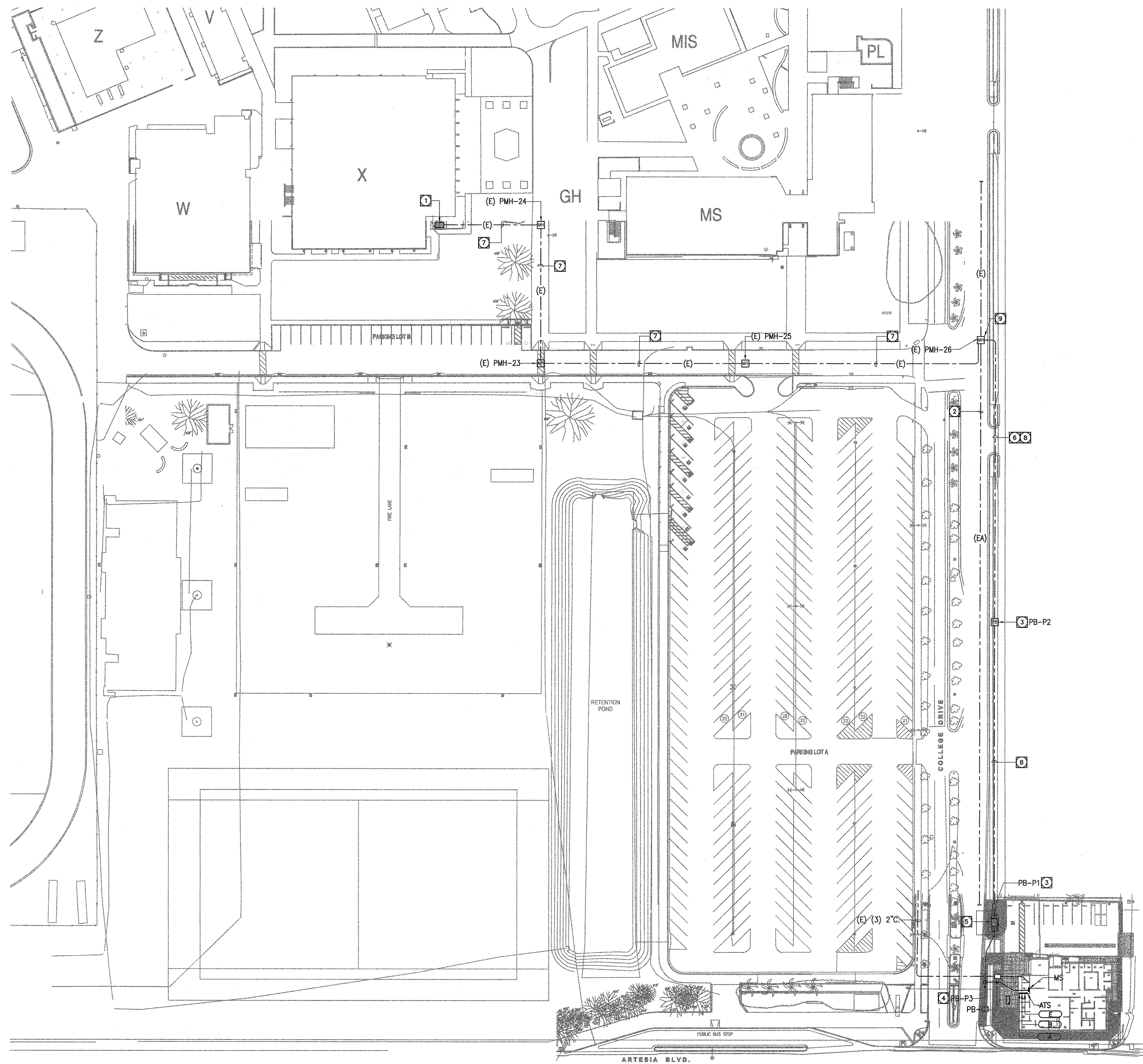

- REFERENCE NOTES**
- 1 EXISTING H.V. POWER SWITCHBOARD "PMH-6". VERIFY EXACT LOCATION IN FIELD. REFER TO SINGLE LINE DIAGRAM ON SHEET EO.0.2 FOR ELECTRICAL SCOPE.
 - 2 EXISTING H.V. INFRASTRUCTURE DUCT BANK. EXISTING 5" SPARE CONDUIT TO BE ABANDONED. REFER TO REFERENCE NOTE #6 (N.I.C.).
 - 3 PROVIDE/INSTALL PRE CAST CONCRETE PULLBOX 3'x5' MIN. DEPTH AS REQUIRED. THE PULLBOX SHALL MEET SIZE REQUIREMENTS IN COMPLIANCE WITH CEC 314.71. REFER TO SHEET E1.1.1 FOR ADDITIONAL REQUIREMENTS (N.I.C.).
 - 4 PROVIDE/INSTALL PRE CAST CONCRETE PULLBOX 2'x3'x DEPTH AS REQUIRED. COMPLETE WITH HEAVY DUTY BOLT DOWN TRAFFIC COVER MARKED "ELECTRIC". REFER TO SHEET E1.1.1 FOR ADDITIONAL REQUIREMENTS.
 - 5 REFER TO SHEET E1.1.1 FOR ENLARGED SITE PLAN.
 - 6 REPLACEMENT (2) 5" UNDERGROUND INFRASTRUCTURE CONDUITS. (N.I.C.).
 - 7 EXISTING H.V. INFRASTRUCTURE DUCT BANK. EXISTING 5" SPARE CONDUIT TO BE UTILIZED FOR ROUTING CONDUCTORS. REFER TO SINGLE LINE DIAGRAM ON SHEET EO.0.2 FOR ADDITIONAL REQUIREMENTS.
 - 8 H.V. CONDUCTORS FOR NEW SUB-STATION TO BE PROVIDED/INSTALLED FROM NEW SUBSTATION TO EXISTING SWITCHBOARD "PMS-6".

EXISTING INFORMATION OBTAINED FROM CAMPUS-WIDE U.G. UTILITY INFRASTRUCTURE - PHASE 1 A#03-113780, CONTRACT #2.

1 ELECTRICAL OVERALL SITE PLAN
1" = 40'-0"

LITTLE
DIVERSIFIED ARCHITECTURAL CONSULTING

1300 Dove Street, Suite 100
Newport Beach, CA 92660
T: 949.698.1400 F: 949.698.1433
www.littleonline.com

This drawing and the design shown are the property of Little Diversified Architectural Consulting. The reproduction, copying or other use of this drawing without their written consent is prohibited and any infringement will be subject to legal action.

© Little 2016

**COMPTON
CCD**

CAMPUS PUBLIC SAFETY BUILDING

**1111 EAST ARTESIA BOULEVARD,
COMPTON CALIFORNIA 90221**

IDENTIFICATION STAMP
DIV. OF THE STATE ARCHITECT
OFFICE OF REGULATION SERVICES

FILE NO: 19-C1
AP: 03-117673

AC: FLS BS P

DATE: DEC. 12, 2017

16516

dHA + CALPEC

180 S. ARROYO PARKWAY
SUITE NO. 180
PASADENA, CA 91105
TEL: (626) 444-8880
FAX: (626) 444-8081

PRINCIPAL IN CHARGE
KEVIN CHEN

PROJECT MANAGER

DRAWN BY
dHA+CALPEC

NO.	REASON	DATE



ELECTRICAL OVERALL
SITE PLAN

913-4675-01

11/21/2017 E1.1.0

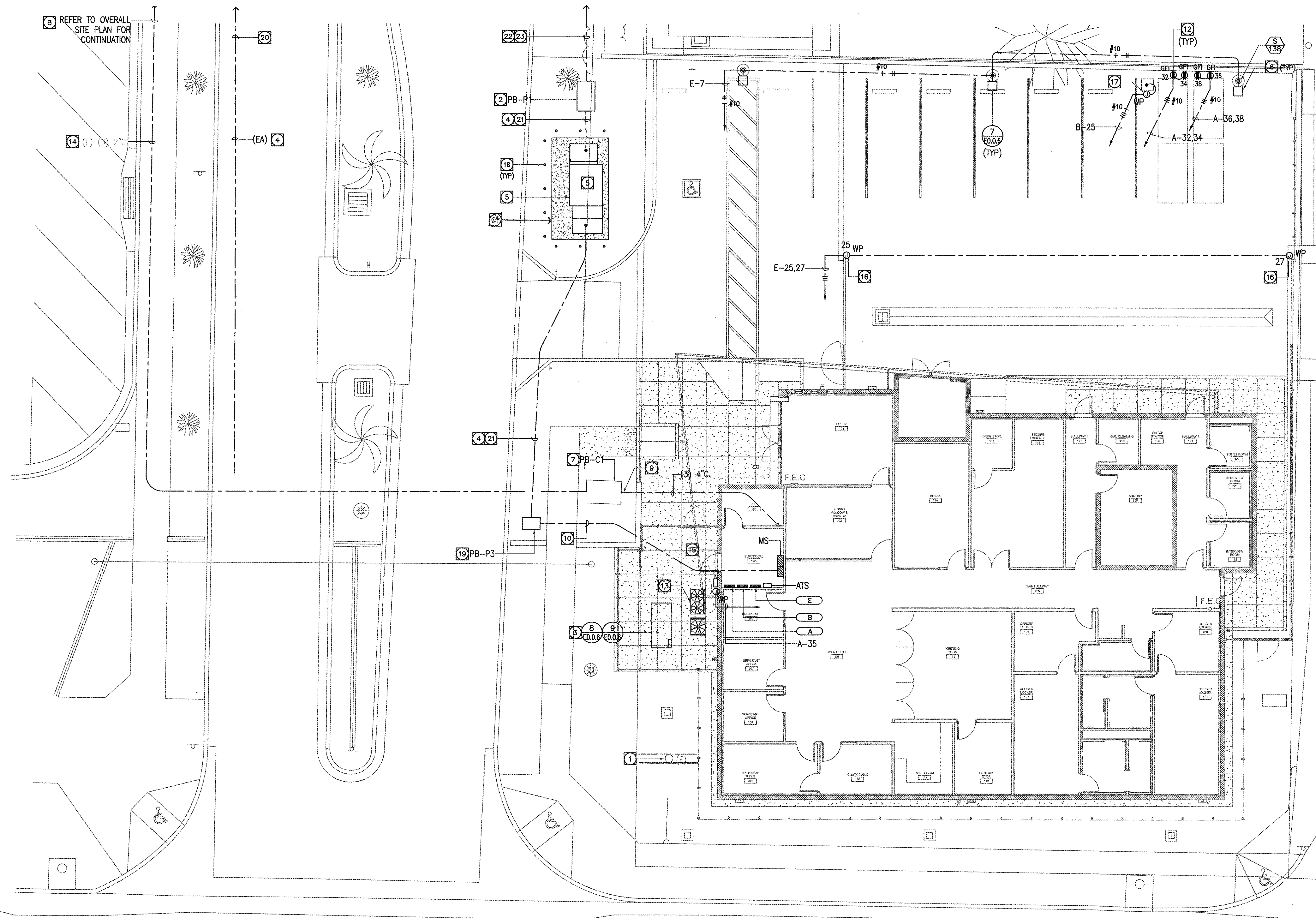

1 ELECTRICAL SITE PLAN
1/8" = 1'-0"

REFERENCE NOTES

- 1 EXISTING UTILITY CO. POWER POLE TO REMAIN.
- 2 PROVIDE/INSTALL PRE CAST CONCRETE PULLBOX 3'x5' MIN. WITH DEPTH AS REQUIRED. THE PULLBOX SHALL MEET SIZE REQUIREMENT IN COMPLIANCE WITH CEC 314.71 COMPLETE WITH HEAVY DUTY TRAFFIC COVER MARKED "HIGH VOLTAGE" (N.I.C.).
- 3 50KW EMERGENCY GENERATOR WITH SOUND ATTENUATED ENCLOSURE. REFER TO SINGLE LINE DIAGRAM.
- 4 REFER TO SINGLE LINE DIAGRAM ON SHEET E0.0.2 FOR FEEDER REQUIREMENTS.
- 5 LOCATION OF NEW PAD MOUNTED SUB-STATION. REFER TO ARCH. SITE PLAN FOR EXACT LOCATION.
- 6 PROVIDE/INSTALL PARKING LOT LIGHT STANDARD. COMPLETE WITH POLE, LED LUMINAIRE AND CONCRETE FOOTING. FIXTURE SHALL BE PROVIDED BY CCC AND INSTALLED BY ELECTRICAL CONTRACTOR.
- 7 EXISTING U.G. CONCRETE PULLBOX WITH HEAVY DUTY TRAFFIC COVER MARKED "COMMUNICATIONS". EXISTING 12/12 SINGLE MODE/MULTIMODE HYBRID FIBER OPTIC CABLE TO BE EXTENDED TO IDF ROOM AT NEW BUILDING.
- 8 TO EXISTING CAMPUS MAIN I.T. ROOM.
- 9 PROVIDE/INSTALL (3) 4"C. EXISTING MULTI-MODE FIBER OPTIC CABLE TO BE EXTENDED TO NEW I.T. ROOM.
- 10 PROVIDE/INSTALL SECONDARY SERVICE FEEDER. REFER TO SINGLE LINE DIAGRAM ON SHEET E0.02 FOR REQUIREMENTS.
- 11 INTERCEPT 5" UNDERGROUND CONDUIT. H.V. CONDUCTORS FROM "PB-1" TO (E) SWITCHBOARD "PMS-6" SHALL BE INSTALLED UNDER SEPARATE CONTRACT (N.I.C.). REFER TO SITE UTILITY NOTES ON THIS SHEET.
- 12 W.P. RECEPTACLE FOR GOLF CART CHARGING. RECEPTACLES SHALL BE RECESSED AT SITE WALL.
- 13 CONDENSER UNIT TO BE PROVIDED WITH EMERGENCY BACKUP POWER PROVISION.
- 14 EXISTING FIBER OPTIC CABLE TO EXISTING MAIN I.T. ROOM.
- 15 IRRIGATION CONTROLLER. VERIFY EXACT LOCATION IN FIELD PRIOR TO INSTALLATION.
- 16 CONNECT TO AUTOMATIC GATE CONTROLLER. VERIFY EXACT LOCATION OF JUNCTION BOX AND P.O.C. IN FIELD PRIOR TO INSTALLATION.
- 17 PROVIDE CONNECTION TO AIR COMPRESSOR.
- 18 PROVIDE/INSTALL STEEL PROTECTIVE BOLLARDS. REFER TO DETAIL - 3/E0.0.7.
- 19 PROVIDE/INSTALL PRECAST CONCRETE PULLBOX 2'x3'x DEPTH AS REQUIRED. COMPLETE HEAVY DUTY TRAFFIC COVER MARKED "ELECTRIC". SET ON 12" OF CRUSHED ROCK. COORDINATE EXACT LOCATION WITH CIVIL AND LANDSCAPE DRAWINGS PRIOR TO INSTALLATION.
- 20 REFER TO SHEET E1.1.0 FOR CONTINUATION.
- 21 PROVIDE ALL SAWCUTTING, TRENCHING, DUCT BANK, AND COMPACTION AS REQUIRED FOR THE COMPLETE DUCT BANK INSTALLATION. REFER TO DETAIL-4/E0.0.5. ROUTE DUCT BANK TO "PB-1". "PB-1" INSTALLED UNDER SEPARATE BID PACKAGE.
- 22 REPLACEMENT (2) 5" UNDERGROUND INFRASTRUCTURE CONDUITS (N.I.C.) INSTALLED UNDER SEPARATE BID PACKAGE. REFER TO SHEET E1.1.0 FOR CONTINUATION.
- 23 H.V. CONDUCTORS FROM "PB-1" TO EXISTING SWITCHBOARD "PMS-6".
- 24 REFER TO A.I.1.1 FOR CHAIN LINK FENCE ENCLOSURE.

SITE UTILITY NOTES

1. CONTRACTOR SHALL CONTACT UNDERGROUND SERVICE ALERT @ (800) 642-2444 48 HOURS PRIOR TO EXCAVATION.
2. CONTRACTOR SHALL INCLUDE AS A PART OF THE BID PROPOSAL THE FOLLOWING:
 - A. PROVIDE REQUIRED MATERIAL AND LABOR FOR REFURBISHING THE FINISH GRADE TO MATCH EXISTING CONDITIONS, IMPACTED BY NEW UNDERGROUND CONDUIT INSTALLATION.
 - B. PROVIDE UTILITY LOCATING EQUIPMENT FOR TRACING EXISTING UNDERGROUND CABLE, CONDUIT, AND PIPING. CONTACT ACCURATE LOCATORS @ (866) 369-1975 FOR EQUIPMENT QUOTATIONS.
 - C. CONTRACTOR SHALL FIELD VERIFY ALL UNDERGROUND UTILITIES PRIOR TO INSTALLING NEW UNDERGROUND CONDUITS.
 - D. CONTRACTOR SHALL REPAIR DAMAGED UNDERGROUND UTILITIES IF NECESSARY IMPACTED BY THE NEW UNDERGROUND CONDUIT SYSTEM. THE COST OF REPAIRING DAMAGED OF EXISTING UNDERGROUND UTILITIES SHALL BE BORNE BY THE CONTRACTOR.

LITTLE
DIVERSIFIED ARCHITECTURAL CONSULTING

1300 Dove Street, Suite 100
Newport Beach, CA 92660
T: 949.698.1400 F: 949.698.1433
www.littleonline.com

This drawing and the design shown are the property of Little Diversified Architectural Consulting. The reproduction, copying or other use of this drawing without their written consent is prohibited and any infringement will be subject to legal action.

© Little 2016

**COMPTON
CCD**

CAMPUS PUBLIC SAFETY BUILDING

**1111 EAST ARTESIA BOULEVARD,
COMPTON CALIFORNIA 90221**

IDENTIFICATION STAMP
DIV. OF THE STATE ARCHITECT
OFFICE OF REGULATION SERVICES

FILE NO: 19-C1
AP: 03-117673

AC: _____ FL: _____ SS: _____
DATE: DEC 12 2017

165116

dHA + CALPEC

180 S. ARROYO PARKWAY
SUITE NO. 100
PASADENA, CA 91105
TEL: (626) 446-8680
FAX: (626) 446-8081

PRINCIPAL IN CHARGE
KEVIN CHEN

PROJECT MANAGER

DRAWN BY
dHA+CALPEC

NO REASON DATE



ELECTRICAL SITE PLAN

913-4675-01

11/21/2017 E1.1.1

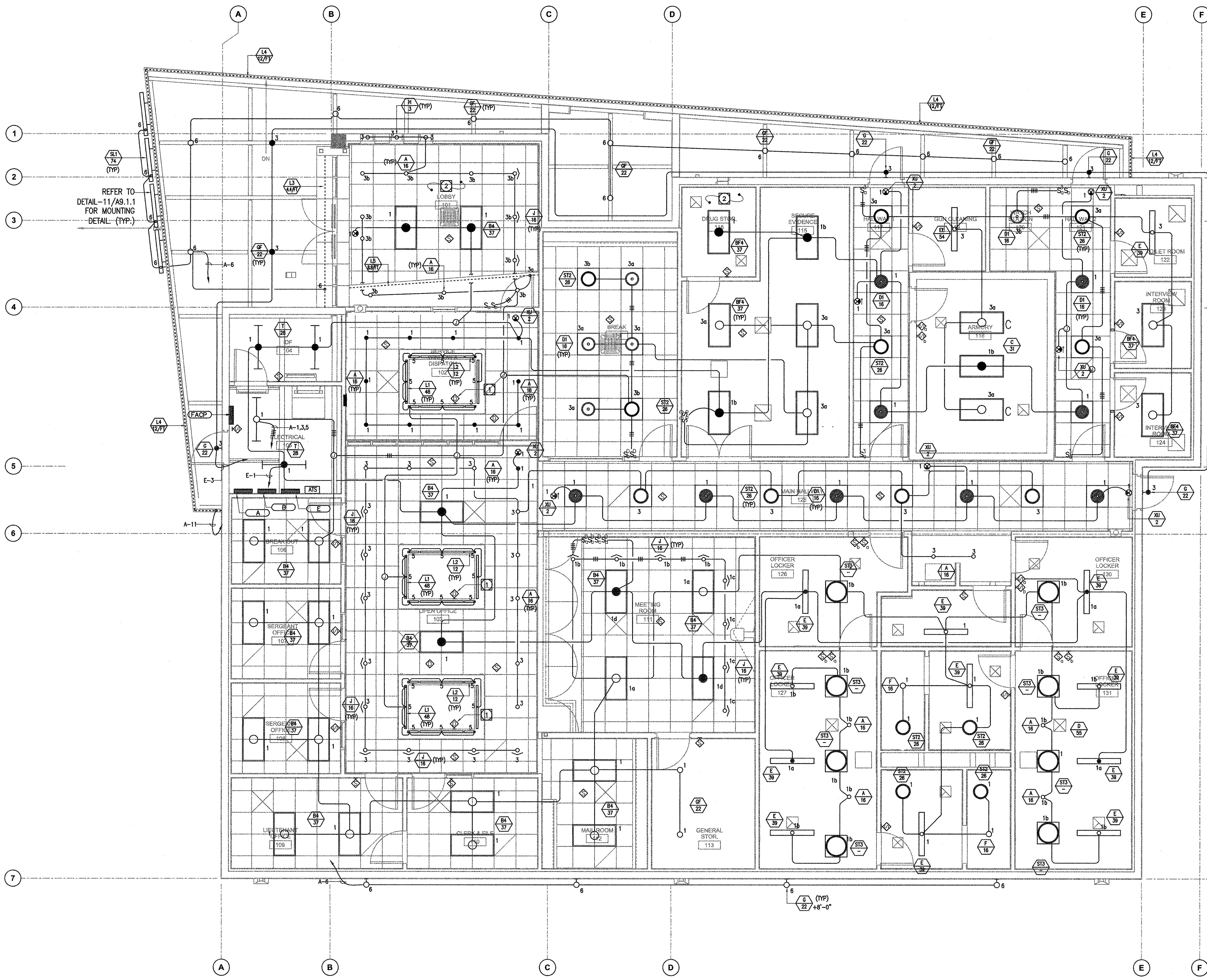

REFER TO
DETAIL-11/A9.1.1
FOR MOUNTING
DETAIL- (TYP.)

REFERENCE NOTES

- 1 LOCATE DAYLIGHT SENSOR IN SKYLIGHT WELL. VERIFY EXACT LOCATION IN FIELD PRIOR TO ROUGH-IN.
- 2 DAYLIGHTING CONTROLS NOT REQUIRED. TOTAL WATTAGE OF LIGHTING LESS THAN 120 WATTS.

GENERAL NOTES

1. AUTOMATIC DAYLIGHTING CONTROLS EXCEPTION 1 OF SECTION 130.1(d)(2): ROOMS IN WHICH THE COMBINED TOTAL INSTALLED GENERAL LIGHTING POWER IN THE SKYLIT DAYLIT ZONE AND PRIMARY SIDELIT DAYLIT ZONE IS LESS THAN 120 WATTS.
2. SECTION 130.1(d)(2)(iv): IN AREAS SERVED BY LIGHTING THAT IS DAYLIGHT CONTROLLED, WHEN THE ILLUMINANCE RECEIVED FROM THE DAYLIGHT IS GREATER THAN 150 PERCENT OF THE DESIGNED ILLUMINANCE RECEIVED FROM THE GENERAL LIGHTING SYSTEM AT FULL POWER, THE GENERAL LIGHTING POWER IN THAT DAYLIGHT ZONE SHALL BE REDUCED BY A MINIMUM OF 65 PERCENT.
3. SECTION 130.1 (b) MULTILEVEL LIGHTING CONTROLS: GENERAL LIGHTING OF ANY ENCLOSED AREA 100 SQUARE FEET OR LARGER, WITH A CONNECTED LIGHTING LOAD THAT EXCEEDS 0.5 WATTS PER SQUARE FOOT SHALL MEET REQUIREMENTS 130.1(b)(1)-3.
4. MULTILEVEL LIGHTING CONTROLS EXCEPTION 2 OF SECTION 130.1(b): AN AREA ENCLOSED BY CEILING HEIGHT PARTITIONS THAT HAS ONLY ONE LUMINAIRE WITH NO MORE THAN TWO LAMPS.
5. DEMAND RESPONSE NOT REQUIRED PER SECTION 130.1 (a) DEMAND RESPONSE CONTROLS: SPACES THAT ARE NONHABITABLE SHALL NOT BE USED TO COMPLY WITH THIS REQUIREMENT, AND SPACES WITH A LIGHTING POWER DENSITY OF LESS THAN 0.5 WATTS PER SQUARE FOOT SHALL NOT BE COUNTED TOWARDS THE BUILDING'S TOTAL LIGHTING POWER.
6. ALL EXISTING LIGHTING IN SCOPE OF WORK TO BE REUTILIZED AND RETROFITTED. U.O.N. SEE FIXTURE SCHEDULE ON SHEET ED.1 FOR DETAILS.

LITTLE
DIVERSIFIED ARCHITECTURAL CONSULTING

4300 Doye Street, Suite 100
Newport Beach, CA 92660
T: 949.698.1400 F: 949.698.1433

www.littleonline.com

This drawing and the design shown are the property of Little Diversified Architectural Consulting. The reproduction, copying or other use of this drawing without their written consent is prohibited and any infringement will be subject to legal action.

© Little 2016

COMPTON
CCD

CAMPUS PUBLIC SAFETY BUILDING

1111 EAST ARTESIA BOULEVARD,
COMPTON CALIFORNIA 90221

IDENTIFICATION STAMP
DIV. OF THE STATE ARCHITECT
OFFICE OF REGULATION SERVICES

FILE NO: 19-C1
AR: 03-117673

AC: [Signature] FL: [Signature] SS: [Signature] AD: [Signature]
DATE: DEC 12 2017

16516 dHA + CALPEC

180 S. ARROYO PARKWAY
SUITE NO. 100
PASADENA, CA 91105
TEL: (626) 446-8880
FAX: (626) 446-8081

PRINCIPAL IN CHARGE
KEVIN CHEN

PROJECT MANAGER

DRAWN BY
dHA+CALPEC

NO REASON DATE

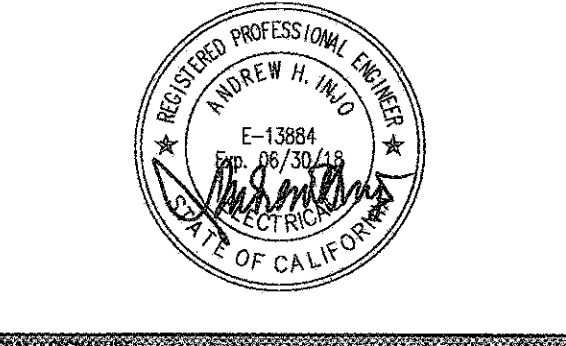

LIGHTING PLAN

913-4675-01

11/21/2017 E2.1.1

1 LIGHTING PLAN
1/4" = 1'-0"

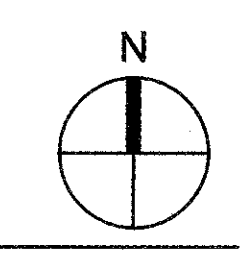

REFERENCE NOTES

- 1 FLOOR OUTLETS FOR MODULAR FURNITURE.
- 2 ELECTRIC DOOR STRIKE TO BE PROVIDED WITH EMERGENCY POWER PROVISION.
- 3 50KW EMERGENCY GENERATOR. REFER TO DETAILS 8 & 9 ON SHEET E.D.0.6.
- 4 NOT USED.
- 5 REMOTE GENERATOR CONTROLLER.
- 6 1" WITH (2) PAIRS 2#12 (THN) AND (1) BELDEN 9841 STRANDED.
- 7 FOR TV MONITOR. MOUNT AT +7'-0".
- 8 ROUTE (2) 1" TO IDF ROOM 131. STUB UP CONDUITS AT EQUIPMENT RACK LOCATION. VERIFY EXACT STUB-UP LOCATIONS IN FIELD WITH CAMPUS IT SERVICES PRIOR TO INSTALLATION.
- 9 REFER TO SINGLE LINE DIAGRAM ON SHEET E.D.0.2 FOR FEEDER SIZE.
- 10 PROVIDE STUB-UPS AND CONNECTIONS TO GENERATOR CONTROL PANEL. VERIFY EXACT STUB-UP LOCATIONS AND P.O.C. IN FIELD PRIOR TO INSTALLATION.
- 11 FOR SURVEILLANCE MONITORS. MOUNT AT +7'-6".
- 12 FOR WALL MOUNTED PROJECTOR. MOUNT RECEPT./DATA OUTLET AT +7'-0" AFF.
- 13 SECURITY CAMERA CONTROLLER.
- 14 ROUTE 3/4" TO MAIN MONITORING CONTROL PANEL.
- 15 ROUTE 1" TO SECURITY SYSTEM CONTROL PANEL LOCATED IN IDF ROOM.
- 16 IDF RACK REFER TO DETAIL A6-19/14.
- 17 STEEL BOLLARD TO HOUSE CARD READER FOR DOUBLE ENTRY DOORS. REFER TO DETAIL-3/A1.3.3 FOR CONDUIT REQUIREMENTS. VERIFY EXACT CONDUIT STUB-UPS AND P.O.C.'S IN FIELD PRIOR TO ROUGH-IN. PROVIDE/INSTALL OUTLET BOX FOR CARD READER.
- 18 ROUTE 1" - 2#12 EG. TO AUTO. DOOR CONTROLLER.
- 19 ROUTE UP INSIDE MULLION AND CONNECT TO AUTO. DOOR CONTROLLER.
- 20 CONNECT TO RECEPTACLE POWER PACK. REFER TO DETAIL 2/E.D.0.3.
- 21 CONNECT TO RECEPTACLE POWER PACK. REFER TO DETAIL 3/E.D.0.3.
- 22 ROUTE CONDUIT INSIDE WALL DOWN TO U.G. CONDUIT.
- 23 IRRIGATION CONTROL PANEL. REFER TO LANDSCAPE DRAWINGS FOR EXACT LOCATION.
- 24 PROVIDE/INSTALL EN INFRARED "ASSISTIVE LISTENING SYSTEM" (ALS). COMPLETE WITH AMPLIFIER, RECEIVER, HEADSETS AND ALL RELATED COMPONENTS REQUIRED FOR A CODE COMPLIANT, COMPLETE/OPERABLE SYSTEM. REFER TO SPEC. SECTION FOR REQUIREMENTS.
- 25 ASSISTIVE LISTENING SYSTEM (ALS) AMPLIFIER TO BE LOCATED IN IDF RACK.
- 26 FOR LIFE-SCAN MACHINE. VERIFY EXACT LOCATION WITH ARCHITECTURAL DRAWINGS.

LITTLE
DIVERSIFIED ARCHITECTURAL CONSULTING

1300 Dove Street, Suite 100
Newport Beach, CA 92660
T: 949.698.1400 F: 949.698.1433
www.littleonline.com

This drawing and the design shown are the property of Little Diversified Architectural Consulting. The reproduction, copying or other use of this drawing without their written consent is prohibited and any infringement will be subject to legal action.

© Little 2016

**COMPTON
CCD**

CAMPUS PUBLIC SAFETY BUILDING

**1111 EAST ARTESIA BOULEVARD,
COMPTON CALIFORNIA 90221**

IDENTIFICATION STAMP
DIV. OF THE STATE ARCHITECT
OFFICE OF REGULATION SERVICES

FILE NO: 19-C1
AP: 03-117673

AC: *[Signature]* FLS: *[Signature]* SS: *[Signature]*
DATE: DEC 12 2017

16516 *[Signature]* dHA + CALPEC

180 S. ARROYO PARKWAY
SUITE NO. 100
PASADENA, CA 91105
TEL: (626) 446-8880
FAX: (626) 446-8081

PRINCIPAL IN CHARGE
KEVIN CHEN

PROJECT MANAGER

DRAWN BY
dHA+CALPEC

NO REASON DATE

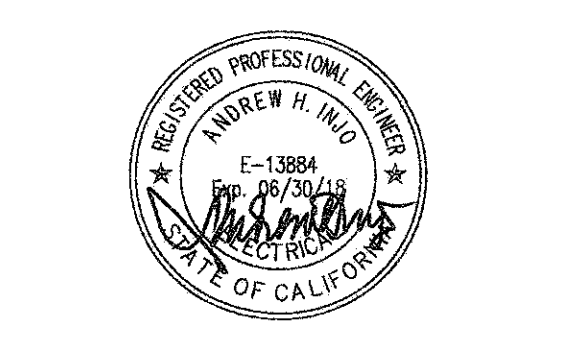

POWER & SIGNAL PLAN

913-4675-01

11/21/2017 E2.1.2

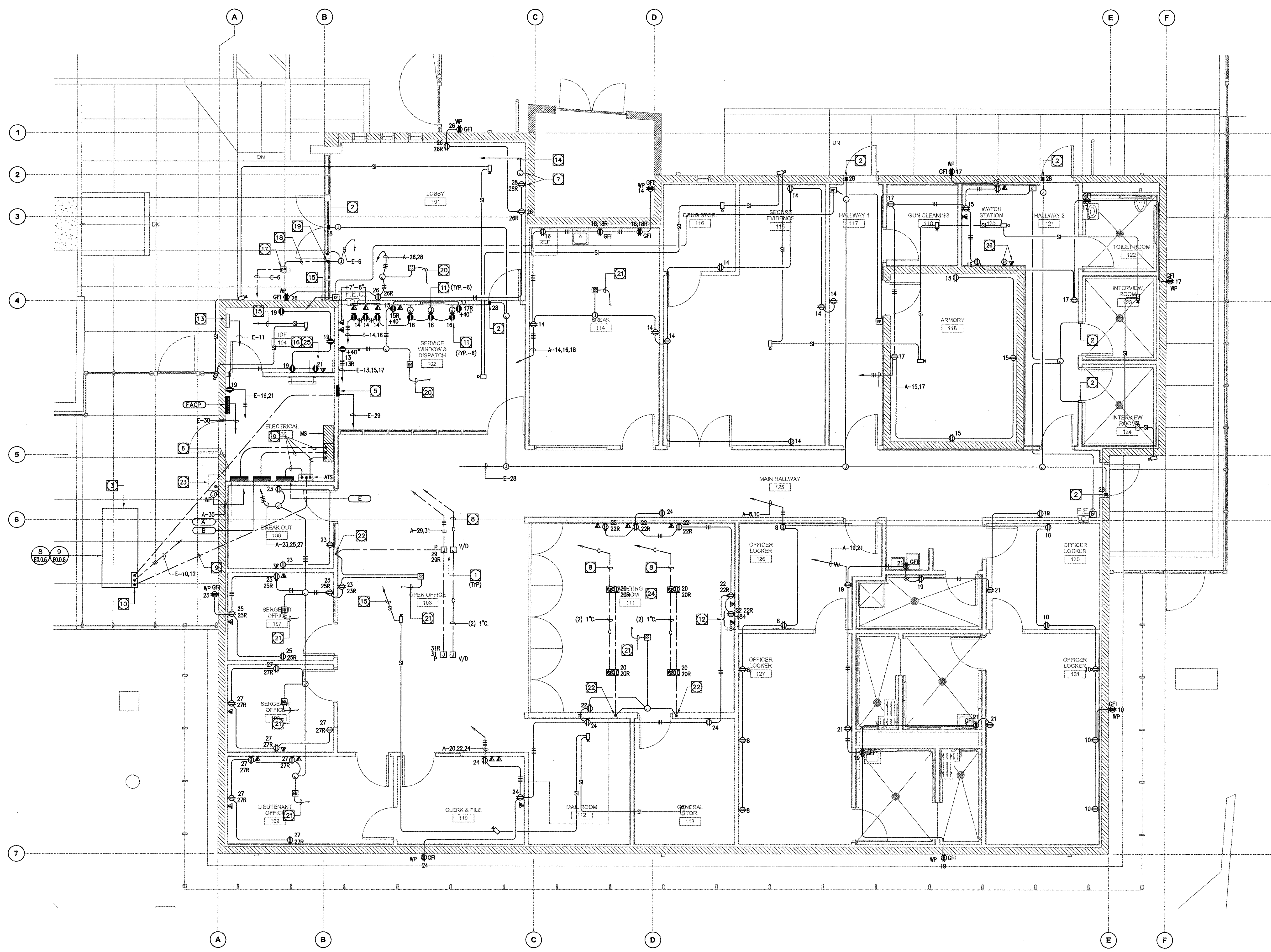

1 POWER & SIGNAL PLAN
1/4" = 1'-0"

REFERENCE NOTES

- 1 VERIFY EXACT LOCATION OF DISCONNECT SWITCH AND P.O.C. IN FIELD WITH MECHANICAL CONTRACTOR PRIOR TO INSTALLATION.
- 2 VERIFY EXACT LOCATION OF P.O.C. IN FIELD WITH PLUMBING CONTRACTOR PRIOR TO INSTALLATION.

LITTLE
DIVERSIFIED ARCHITECTURAL CONSULTING

4300 Dove Street, Suite 100
Newport Beach, CA 92660
T: 949.698.1400 F: 949.698.1433

www.littleonline.com

This drawing and the design shown are the property of Little Diversified Architectural Consulting. The reproduction, copying or other use of this drawing without their written consent is prohibited and any infringement will be subject to legal action.

© Little 2016

**COMPTON
CCD**

CAMPUS PUBLIC SAFETY BUILDING

**1111 EAST ARTESIA BOULEVARD,
COMPTON CALIFORNIA 90221**

IDENTIFICATION STAMP
DIV. OF THE STATE ARCHITECT
OFFICE OF REGULATION SERVICES
FILE NO: 19-C1
AP: 03-117673
AC: [Signature] PLS [Signature] SS
DATE: DEC 12 2017

16516 dHA + CALPEC
180 S. ARROYO PARKWAY
SUITE NO. 180
PASADENA, CA. 91105
TEL: (626) 446-8880
FAX: (626) 446-8881

PRINCIPAL IN CHARGE

KEVIN CHEN

PROJECT MANAGER

DRAWN BY

dHA+CALPEC

NO REASON DATE



**ELECTRICAL
MECHANICAL POWER
PLAN**

913-4675-01

11/21/2017 E2.1.3

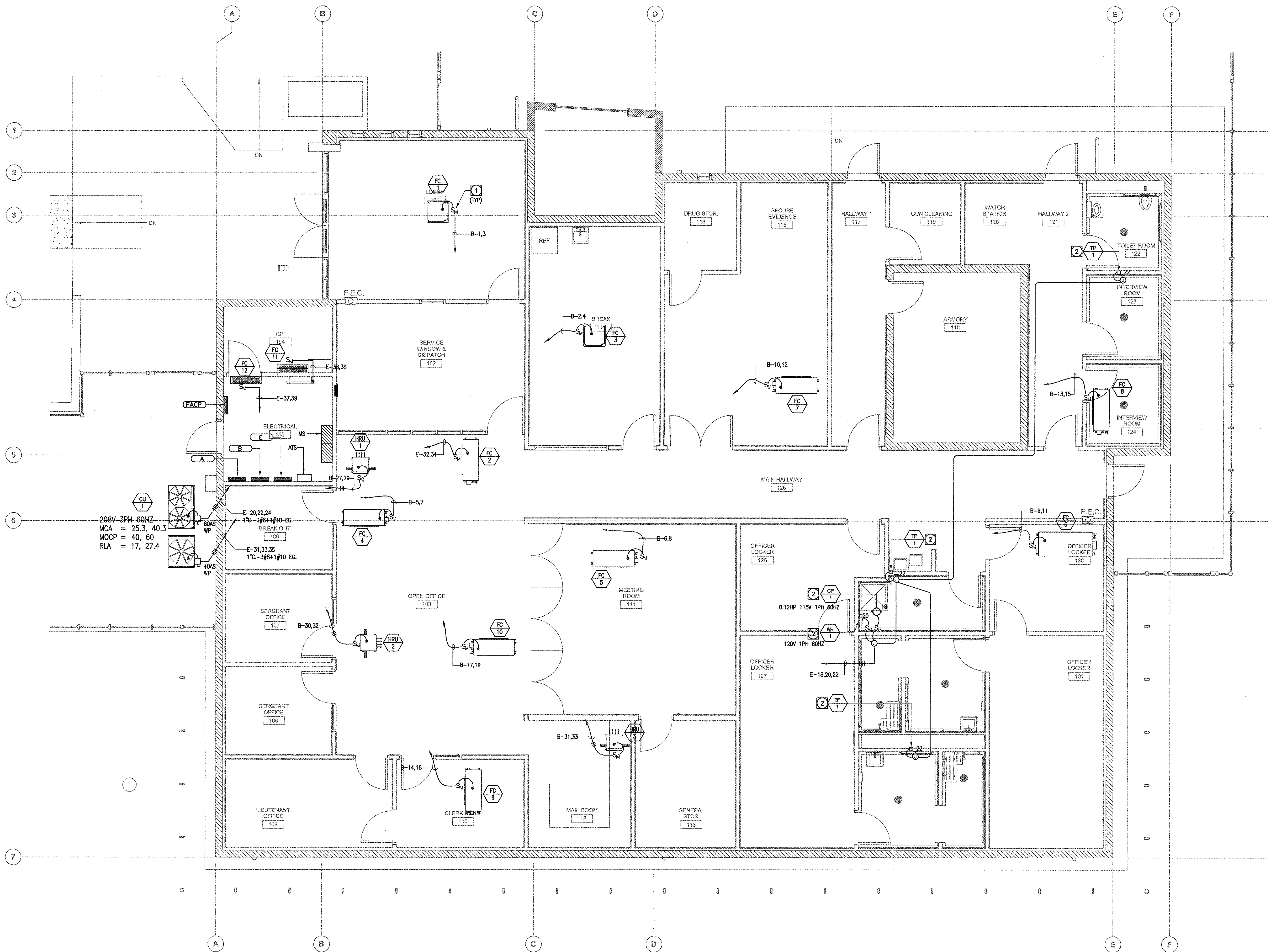

1 ELECTRICAL MECHANICAL POWER PLAN
1/4" = 1'-0"

**COMPTON
CCD**

CAMPUS PUBLIC SAFETY BUILDING
**1111 EAST ARTESIA BOULEVARD,
COMPTON CALIFORNIA 90221**

IDENTIFICATION STAMP
DIV. OF THE STATE ARCHITECT
OFFICE OF REGULATION SERVICES

FILE NO:	19-C1
AR:	03-117673
AC:	FLS <i>FLS</i> SS <i>SS</i>
DATE:	DEC 12 2017

16516
dHA + CALPEC
180 S. ARROYO PARKWAY
SUITE NO. 100
PASADENA, CA 91105
TEL: (626) 445-8880
FAX: (626) 445-8081

PRINCIPAL IN CHARGE
KEVIN CHEN
PROJECT MANAGER
DRAWN BY
dHA+CALPEC
NO REASON DATE



ELECTRICAL ROOF PLAN

913-4675-01

11/21/2017 E3.1.1

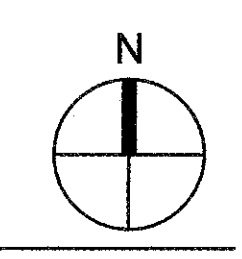
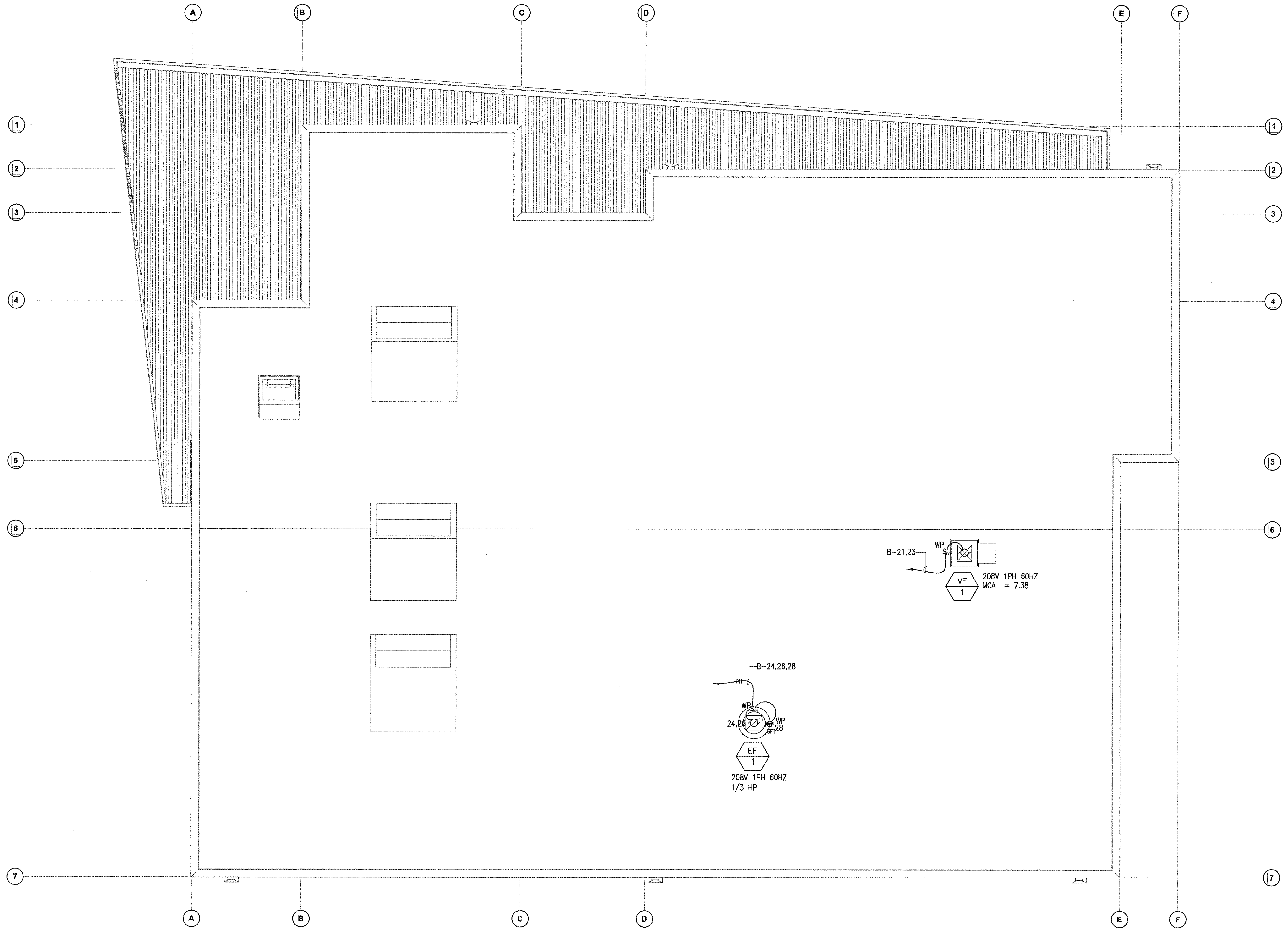

1 ELECTRICAL ROOF PLAN
1/4" = 1'-0"

ELECTRICAL SPECIFICATIONS

- 1. MINIMUM SIZE OF CONDUIT SHALL BE 3/4", MINIMUM SIZE OF CONDUCTOR SHALL BE #12 AWG UNLESS OTHERWISE NOTED.
2. WHERE WIRE SIZES ARE INDICATED ON PLANS, FOR INDIVIDUAL CIRCUITS, THE WIRE SIZE INDICATED SHALL APPLY TO THE COMPLETE CIRCUIT, UNLESS OTHERWISE NOTED.
3. ALL JUNCTION BOXES AND PULL BOXES SHALL BE OF CODE GAUGE AND OF THE REQUIRED SIZE TO ACCOMMODATE NUMBER OF CONDUCTORS SHOWN.
4. ALL PULL BOXES IN FINISHED AREAS SHALL HAVE FACTORY APPLIED PRIME COAT OF PAINT.
5. ELECTRICAL CONTRACTOR SHALL COORDINATE THE LOCATION OF ALL WALL OUTLET BOXES FOR CLOCKS, SWITCHES, HORNS FIRE ALARM MANUAL PULL STATIONS, SPEAKERS, RECEPTACLES ETC.
6. FURNISH FISH WIRE IN EACH RACEWAY RUN OVER 10' IN LENGTH, IN WHICH PERMANENT WIRING IS NOT INSTALLED.
7. PROVIDE PULL BOXES WHEREVER NECESSARY TO FACILITATE PULLING OF CONDUCTORS. COORDINATE LOCATIONS OF BOXES WITH OTHER TRADES TO AVOID CONFLICT.
8. SUPPORT JUNCTION AND PULL BOXES INDEPENDENTLY TO BUILDING STRUCTURE WITH NO WEIGHT BEARING ON RACEWAYS.
9. NO CONDUIT RUNS WILL BE ALLOWED IN CONCRETE SLAB. ALL CONDUITS WILL BE PLACED IN THE HUNG CEILING UNLESS SPECIFICALLY INDICATED TO BE UNDERGROUND.
10. ALL CONDUIT PENETRATIONS THROUGH FIRE RATED WALLS AND FLOORS SHALL BE PROTECTED BY MATERIALS TESTED IN ACCORDANCE WITH UL1479/ASTM E-814. INSTALLATION SHALL FOLLOW MANUFACTURER'S INSTRUCTIONS AND MAINTAIN THE FIRE RATING OF WALLS AND/OR FLOORS AFFECTED. PROVIDE HILT CS240 FIRESTOP SEALANT, CSFM LISTING NO. 4060-1200:100, OR EQUIVALENT STATE FIRE MARSHALL APPROVED AND LISTED MATERIAL.
11. IDENTIFICATION NAMEPLATES SHALL BE MICARTA 1/8" THICK AND OF APPROVED SIZE WITH BEVELED EDGES AND ENGRAVED WHITE LETTERS A MINIMUM OF 1/4" HIGH ON BLACK BACKGROUND. NAMEPLATES SHALL BE PROVIDED FOR FIRE ALARM CONTROL PANEL, POWER SUPPLY CABINET AND PULLBOXES. ALL NAMEPLATES SHALL BE ATTACHED WITH SCREWS. PULL BOXES, JUNCTION BOXES, AND DEVICE BOXES SHALL BE MARKED WITH A PERMANENT MARKER.
12. THE CONTRACTOR SHALL PROVIDE AND KEEP UP-TO-DATE A COMPLETE RECORD SET OF DRAWINGS. THESE PRINTS SHALL BE CORRECTED DAILY AND SHOW EVERY CHANGE FROM THE ORIGINAL DRAWINGS. THIS SET OF DRAWINGS SHALL BE KEPT ON THE JOB SITE AND SHALL BE USED ONLY AS A RECORD SET. THIS SHALL NOT BE CONSTRUED AS AUTHORIZATION FOR THE CONTRACTOR TO MAKE CHANGES IN THE LAYOUT WITHOUT DEFINITE INSTRUCTION IN EACH CASE. UPON COMPLETION OF THE WORK, A SET OF REPRODUCIBLE CONTRACT DRAWINGS SHALL BE OBTAINED FROM THE ARCHITECT, AND ALL CHANGES AS NOTED ON THE RECORD SET OF DRAWINGS SHALL BE INCORPORATED THEREON WITH BLACK INK IN A NEAT, LEGIBLE, UNDERSTANDABLE AND PROFESSIONAL MANNER.
13. SHOP DRAWINGS (SUBMITTAL BOOKLET) SHALL BE SUBMITTED WITHIN THIRTY DAYS AFTER AWARD OF THE CONTRACT. THE CONTRACTOR SHALL SUBMIT EIGHT COPIES OF A COMPLETE LIST OF MATERIALS AND EQUIPMENT INCLUDING MANUFACTURER AND MODEL NUMBER PROPOSED FOR THE JOB. SHOP DRAWINGS SHALL INCLUDE JOB DESCRIPTION, ARCHITECT AND ENGINEER IDENTIFICATION, AND ALL DATA WITH CAPACITIES, SIZES, DIMENSIONS, CATALOG NUMBERS, AND MANUFACTURER'S BROCHURES. SHOP DRAWINGS SHALL BE SUBMITTED FOR ITEMS LISTED IN THE FIRE ALARM SYMBOLS LIST. PARTIAL, INCOMPLETE, OR UNBOUND SUBMITTALS WILL BE RETURNED WITHOUT REVIEW.
14. AFTER ALL REQUIREMENTS OF THE SPECIFICATIONS AND/OR THE DRAWINGS HAVE BEEN FULLY COMPLETED, REPRESENTATIVES OF THE OWNER WILL INSPECT THE WORK. THE CONTRACTOR SHALL PROVIDE COMPETENT PERSONNEL TO DEMONSTRATE THE OPERATION OF ANY ITEM OR SYSTEM TO THE FULL SATISFACTION OF EACH REPRESENTATIVE. FINAL ACCEPTANCE OF THE WORK WILL BE MADE BY THE OWNER AFTER RECEIPT OF APPROVAL AND RECOMMENDATION OF ACCEPTANCE FORM EACH REPRESENTATIVE.

FIRE ALARM WIRING LEGEND

Table with 4 columns: CIRCUIT DESCRIPTION, WIRE, SINGLE CONDUCTOR (THHN, TFFN), PLENUM RATED: F/PL. Includes rows for MAPNET/DINET CIRCUIT 1, VISUAL/SIGNAL CIRCUIT - 2 CONDUCTOR 12 AWG STRANDED, NOTIFICATION APPLIANCE CIRCUIT - 2 CONDUCTOR #14 STRANDED TWP, R/UA COMMUNICATION 1 PAIR 18 AWG UNSHIELDED TWISTED (SUBSCRIPT "u" IF MIXED w/SHIELDED), POWER CIRCUIT 2 CONDUCTOR 14 AWG SOLID (SUBSCRIPT "s" IF RESETTABLE).

THE CABLES SPECIFIED HERE ARE FOR REFERENCE OF REQUIRED ELECTRICAL CHARACTERISTICS AS WELL AS CODE REQUIREMENTS. ALTERNATE SUPPLIERS MAY BE SUBSTITUTED PROVIDING EQUIVALENT CHARACTERISTICS ARE MAINTAINED. ITEMS SUCH AS CAPACITANCE BETWEEN CONDUCTORS AND WIRE GAUGE CAN BE CRUCIAL TO THE CIRCUIT DESIGN OF THE SYSTEM INSTALLATION. REFERENCE: HTTPS://WWW.ANIXTER.COM/CUSTOMER/TYCOFS FOR SG ANIXTER CABLE DATA

SHEET LIST

- FA0.1 FIRE ALARM LEGENDS & NOTES
FA0.2 FIRE ALARM RISER DIAGRAM
FA0.3 FIRE ALARM DETAILS
FA0.3.1 FIRE ALARM DETAILS
FA0.3.2 FIRE ALARM DETAILS
FA0.4 FIRE ALARM CALCULATIONS
FA2.1 FIRE ALARM PLAN

FIRE ALARM SYMBOLS

Table with 5 columns: SYMBOL, DESCRIPTION, MANUFACTURER, MODEL NO, C.S.F.M. Includes symbols for FIRE ALARM CONTROL PANEL, LCD REMOTE ANNUNCIATOR, SMOKE DETECTOR, MANUAL PULL STATION, HORN/STROBE (15CD) WALL, HORN/STROBE (75CD) WALL, STROBE (15CD) WALL, WEATHER PROOF HORN/STROBE 15CD, SDACT - DIGITAL ALARM COMMUNICATING TRANSMITTER MODULE, and DIALER.

SEISMIC BRACING NOTES

MEP COMPONENT ANCHORAGE NOTE

ALL MECHANICAL, PLUMBING, AND ELECTRICAL COMPONENTS SHALL BE ANCHORED AND INSTALLED PER THE DETAILS ON THE DSA APPROVED CONSTRUCTION DOCUMENTS. WHERE NO DETAIL IS INDICATED, THE FOLLOWING COMPONENTS SHALL BE ANCHORED OR BRACED TO MEET THE FORCE AND DISPLACEMENT REQUIREMENTS PRESCRIBED IN THE 2013 CBC, SECTIONS 1616A.1.18 THROUGH 1616A.1.26 AND ASCE 7-10 CHAPTER 6 AND 30.

- 1. ALL PERMANENT EQUIPMENT AND COMPONENTS.
2. TEMPORARY OR MOVABLE EQUIPMENT THAT IS PERMANENTLY ATTACHED (E.G. HARD WIRED) TO THE BUILDING UTILITY SERVICES AS ELECTRICITY, GAS OR WATER.
3. MOVABLE EQUIPMENT WHICH IS STATIONED IN ONE PLACE FOR MORE THAN 8 HOURS AND HEAVIER THAN 400 POUNDS ARE REQUIRED TO BE ANCHORED WITH TEMPORARY ATTACHMENTS.

THE ATTACHMENT OF THE FOLLOWING MECHANICAL AND ELECTRICAL COMPONENTS SHALL BE POSITIVELY ATTACHED TO THE STRUCTURE, BUT NEED NOT BE DETAILED ON THE PLANS. THESE COMPONENTS SHALL HAVE FLEXIBLE CONNECTIONS PROVIDED BETWEEN THE COMPONENT AND ASSOCIATED DUCTWORK, PIPING, AND CONDUIT.

- A. COMPONENTS WEIGHING LESS THAN 400 POUNDS AND HAVE A CENTER OF MASS LOCATED 4 FEET OR LESS ABOVE THE ADJACENT FLOOR OR ROOF LEVEL THAT DIRECTLY SUPPORT THE COMPONENT.
B. COMPONENTS WEIGHING LESS THAN 20 POUNDS, OR IN THE CASE OF DISTRIBUTED SYSTEMS, LESS THAN 5 POUNDS PER FOOT, WHICH ARE SUSPENDED FROM A ROOF OR FLOOR OR HUNG FROM A WALL.

FOR THOSE ELEMENTS THAT DO NOT REQUIRE DETAILS ON THE APPROVED DRAWINGS, THE INSTALLATION SHALL BE SUBJECT TO THE APPROVAL OF THE STRUCTURAL ENGINEER OF RECORD AND THE DSA DISTRICT STRUCTURAL ENGINEER. THE PROJECT INSPECTOR WILL VERIFY THAT ALL COMPONENTS AND EQUIPMENT HAVE BEEN ANCHORED IN ACCORDANCE WITH ABOVE REQUIREMENTS.

PIPING, DUCTWORK, AND ELECTRICAL DISTRIBUTION SYSTEM BRACING NOTE
PIPING, DUCTWORK, AND ELECTRICAL DISTRIBUTION SYSTEMS SHALL BE BRACED TO COMPLY WITH THE FORCES AND DISPLACEMENTS PRESCRIBED IN ASCE 7-10 SECTION 13.3 AS DEFINED IN ASCE 7-10 SECTION 13.6.8, 13.6.7, 13.6.5.6, AND 2013 CBC, SECTIONS 1616A.1.23, 1616A.1.24, 1616A.1.25 AND 1616A.1.26.

THE BRACING AND ATTACHMENTS TO THE STRUCTURE SHALL BE DETAILED ON THE APPROVED DRAWINGS OR THEY SHALL COMPLY WITH ONE OF THE DSA PRE-APPROVALS (OP#) AS MODIFIED TO SATISFY ANCHORAGE REQUIREMENTS OF ACI 318, APPENDIX D. MASON INDUSTRIES OPM-0043-13.

COPIES OF THE MANUAL SHALL BE AVAILABLE ON THE JOBSITE PRIOR TO THE START OF HANGING AND BRACING OF THE PIPE, DUCTWORK, AND ELECTRICAL DISTRIBUTION SYSTEMS.

THE STRUCTURAL ENGINEER OF RECORD SHALL VERIFY THE ADEQUACY THE STRUCTURE TO SUPPORT THE HANGER AND BRACE LOADS.

F.A. DEVICE MOUNTING DETAIL

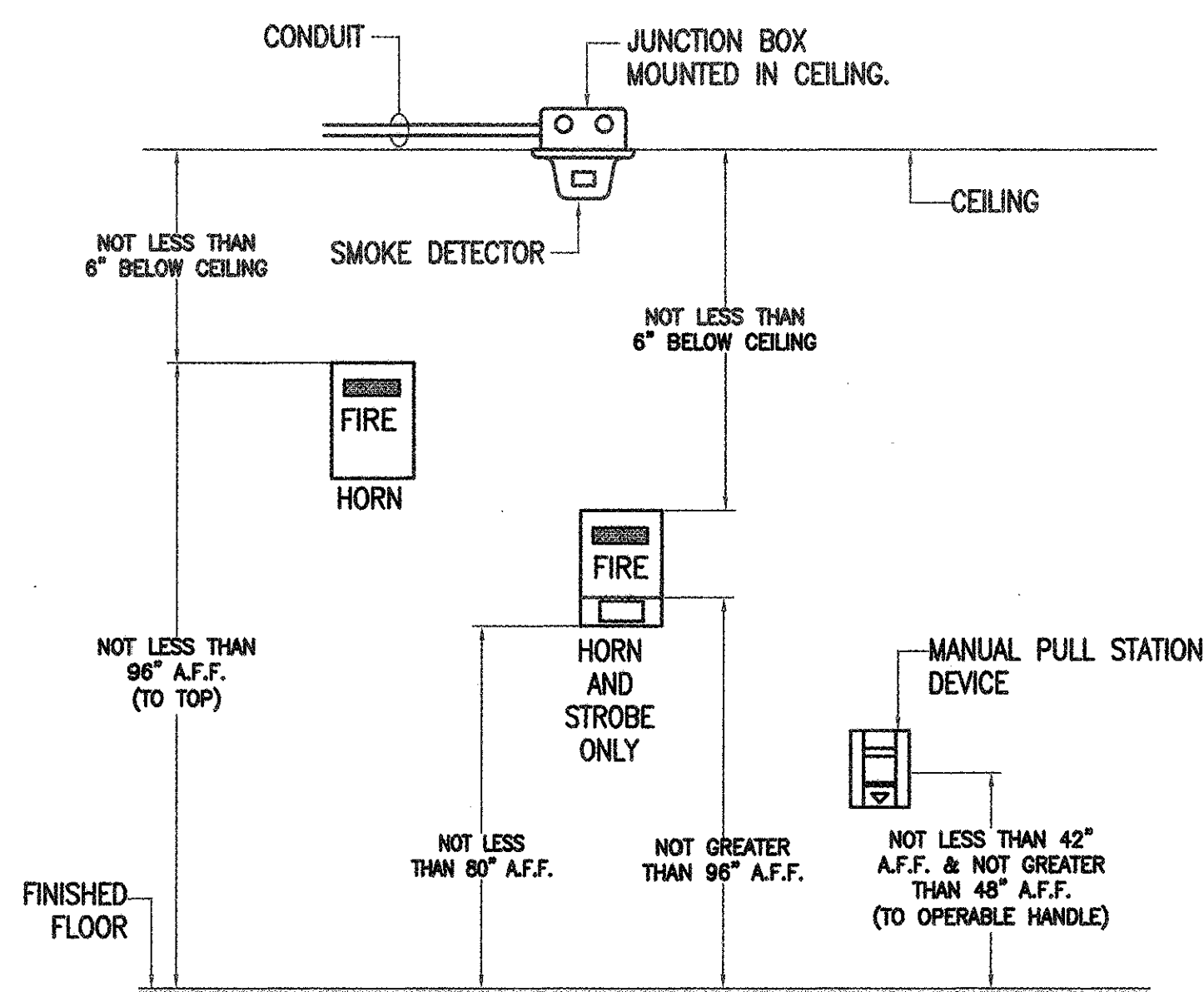

FIRE ALARM CABLE REQUIREMENTS

- 1. NOTIFICATION APPLIANCE CIRCUITS (STROBE, HORNS):
a. 2#12 CU.THHN CONDUCTORS. STROBE/AUDIBLE CKT.
2. 24VDC POWER DISTRIBUTIVE CIRCUITS (MODULES AND DETECTORS WITH RELAY BASE):
a. #12 CU.THHN CONDUCTORS.
3. ADDRESSABLE DEVICES CIRCUITS: (MODULES AND DETECTORS)
a. (1) WESTPENN #0990 2/C #18 TWISTED SHIELDED PAIR CABLE.

REFER TO WIRE SCHEDULE THIS SHEET FOR DETAILED REQUIREMENTS.

FIRE ALARM SCOPE OF WORK

PROJECT SHALL CONSIST OF INSTALLATION OF NEW FIRE ALARM CONTROL PANEL AND DEVICES AT NEW CAMPUS PUBLIC SAFETY BUILDING. FIRE ALARM SYSTEM BASED ON SIMPLEX 4100 FIRE ALARM CONTROL PANEL.

AT THE COMPLETION OF THE PROJECT, THE FIRE ALARM SYSTEM SHALL BE TESTED AND CERTIFIED, COORDINATE WITH FIRE INSPECTOR FOR CERTIFICATION REQUIREMENT.

FIRE ALARM DEVICE IDENTIFICATION

INITIATION DEVICE

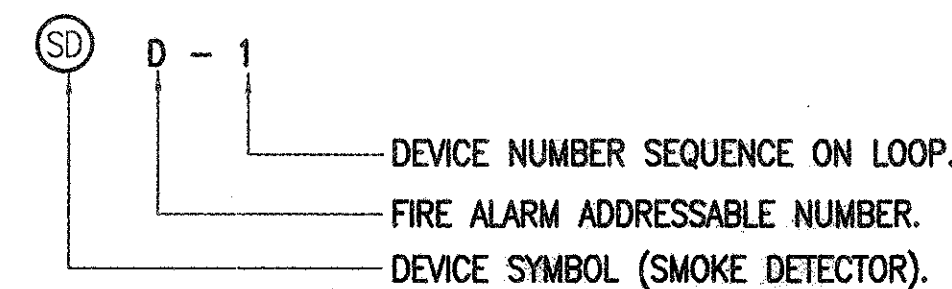

NOTIFICATION APPLIANCE CIRCUIT DEVICE (N.A.C.)

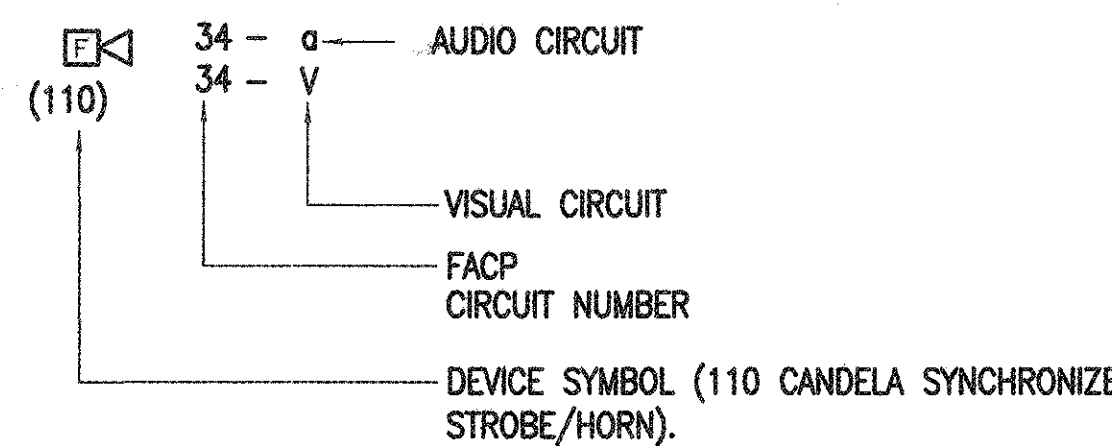

WIRING METHOD:

- A. SLC CIRCUIT (ADDRESSABLE ANALOG DEVICES), CLASS B.
B. SLC CIRCUIT (DATA, AUDIO) STYLE 7, CLASS A.
C. INITIATION CIRCUIT STYLE A OR B, CLASS B.
D. NOTIFICATION APPLIANCE CIRCUIT, STYLE Y, CLASS B.

FIRE ALARM NOTES

- 1. ALL WIRING INITIATING DEVICE AND ANNUNCIATOR PANEL WIRING SHALL BE SUPERVISED TO THE PRINCIPAL POINT OF ANNUNCIATION (F/A PANEL TO SUPERVISE THE ANNUNCIATOR PANEL, ALL CIRCUITS AND INITIATING DEVICES).
2. WIRING SHALL NOT BE LOOPED THROUGH DEVICES, WIRE MUST BE CUT FOR IN AND OUT POINT AND COMMON ANNUNCIATION AND T-TAPPING PROHIBITED EXCEPTION:
3. "T" TAPPING IS ALLOWED FOR MAPNET COMMUNICATION LOOP CLASS "B" STYLE 4 WIRING ONLY. INITIATION CIRCUIT, CLASS B, STYLE B OR A. NOTIFICATION APPLIANCE CIRCUIT, CLASS "B" STYLE Y WIRING ONLY. ALL WIRING TO BE IN CONDUIT WITH SIZES AS INDICATED ON CONDUIT SCHEDULE. THE FIRE ALARM CONTROL PANEL IS NOT TO BE USED AS A TERMINAL CABINET. ALL CONDUIT SIZES INDICATED IN DRAWINGS ARE MINIMUMS CONTRACTOR TO ADJUST SIZE FOR FIELD CONDITIONS (IE. NO OF BENDS, ETC.) BUT SHALL NOT BE SMALLER THAN 3/4".
4. ALL FIRE ALARM WIRING MUST TEST FREE OF OPENS, SHORTS AND GROUNDS. ALL FIRE ALARM WIRING MUST ENTER AT THE TOP AND BOTTOM RIGHT OF THE FIRE ALARM CONTROL PANEL.
5. FIRE ALARM DRAWINGS ARE SCHEMATIC IN NATURE ONLY CONTRACTOR TO ROUTE CONDUIT AS FIELD CONDITIONS INDICATE.
6. CONDUIT AND JUNCTION/BACK BOXES ARE NOT TO BE USED FOR UNRELATED WIRING.
7. PULL STATIONS SHALL BE MOUNTED PER DETAIL THIS SHEET PER NFPA-72 SECTION 17.14.5.
8. PENETRATIONS TO FIRE RATED ASSEMBLIES SHALL BE PROTECTED BY A UL APPROVED THROUGH-PENETRATION FIRE-STOP SYSTEM.
9. ALL CABLE SHIELDING SHALL BE ISOLATED FROM GROUND EXCEPT AT THE MFACP AND SHALL MAINTAIN CONTINUITY THROUGHOUT.
10. CHANGES TO SUGGEST WIRE TYPE AND ROUTE MUST BE APPROVED IN WRITING BY SIMPLEX SYSTEMS PRIOR TO USE.
11. THE FIRE ALARM SYSTEM SHALL CONFORM TO ARTICLE 760 OF CALIFORNIA ELECTRICAL CODE.
12. INSTALLATION OF THE FIRE ALARM SYSTEM SHALL NOT BE STARTED UNTIL DETAILED PLANS AND SPECIFICATIONS, INCLUDING CALIFORNIA STATE FIRE MARSHALL LISTING NUMBERS FOR EACH COMPONENT OF THE SYSTEM HAVE BEEN APPROVED BY DSA.
13. UPON COMPLETION OF THE INSTALLATION OF THE FIRE ALARM SYSTEM A SATISFACTORY TEST OF THE ENTIRE SYSTEM SHALL BE MADE IN THE PRESENCE OF THE ENFORCING AGENCY.
14. ALL DEVICES IN THE ALARM SYSTEM SHALL BE COMPATIBLE AND INSTALLED TO MANUFACTURER'S SPECIFICATIONS.
15. AUDIBILITY OF ALARM AND VOICE COMMUNICATION SHALL BE NOT LESS THAN 15 DBA ABOVE AMBIENT SOUND, BUT NOT LESS THAN 75 DBA, THROUGHOUT AREA OF ALARM.
16. AREAS HAVING MORE THAN 2 STROBES IN THE FIELD OF VIEW SHALL BE SYNCHRONIZED.
17. SMOKE DETECTORS AND HEAT DETECTOR LOCATIONS ARE BASED ON SMOOTH CEILING WITH MAXIMUM HEIGHT OF 10 FEET UNLESS OTHERWISE NOTED.
18. STROBE LOCATION IS BASE ON 10 FOOT CEILING HEIGHT AND ARE INSTALLED ACCORDING TO NFPA 72 REQUIREMENTS UNLESS OTHERWISE NOTED.
19. WALL-MOUNTED STROBES SHALL HAVE THEIR BOTTOMS NOT LESS THAN 80 INCHES ABOVE FINISHED FLOOR AND NO GREATER THEN 96 INCHES ABOVE FINISHED FLOOR.
20. NO HORIZONTAL OR VERTICAL CONDUIT RUNS ARE PERMITTED IN CMU OR CONCRETE WALLS.
21. FIRE ALARM INSTALLER SHALL BE RESPONSIBLE FOR IDENTIFYING REQUIRED TESTING BY THE STATE FIRE MARSHAL AND LOCAL AUTHORITIES HAVING JURISDICTION (AHJ), COORDINATING, SCHEDULING, AND CONDUCTING TEST BEFORE SUBSTANTIAL COMPLETION.
22. FIRE ALARM CONTRACTOR SHALL BE RESPONSIBLE TO PROVIDE AN APPROVED FIRE WATCH SERVICE WHERE A REQUIRED FIRE PROTECTION SYSTEM OUT OF SERVICE OR IMPAIRMENT DURING CONSTRUCTION. FIRE WATCH SERVICE SHALL BE PROVIDED UNTIL THE FIRE PROTECTION SYSTEM IS RETURNED TO SERVICE.
23. ALL CONDUIT SHALL BE CONNECTED WHERE AT ALL POSSIBLE.
24. ALL EXPOSED CONDUIT & PIPE TO BE PAINTED - COLOR PER ARCHITECT.

FACP ALARM SEQUENCE OF OPERATION

Table with 5 columns: DEVICE ACTION, MANUAL PULL STATION, ALARM AT REMOTE NETWORK FACP, AREA SMOKE & HEAT DETECTORS, DUCT DETECTOR (NOT USED). Rows include ANNUNCIATE AT MAIN FACP & AT NETWORK ANNUNCIATOR, ANNUNCIATE AT CENTRAL STATION, ALARM AT SECURITY PANEL, RELEASE DOOR LATCHES FOR SECURITY SYSTEM, HVAC UNIT SHUT DOWN, SMOKE/FIRE DAMPER SHUT DOWN, PA SYSTEM BACKGROUND MUSIC SHUT DOWN.

NOTE: IF DEVICE/ACTION FUNCTION DOESN'T APPLY TO THE CURRENT PROJECT, INDICATE AS "N/A"
* ON SPRINKLER WATER FLOW ALARM ONLY
** AS SUPERVISORY ONLY

APPLICABLE CODES

- 2013 BUILDING STANDARDS ADMINISTRATIVE CODE, PART 1, TITLE 24 C.C.R.
2013 CALIFORNIA BUILDING CODE (CBC), PART 2, TITLE 24 C.C.R.
2013 CALIFORNIA ELECTRICAL CODE (CEC), PART 3, TITLE 24 C.C.R.
2013 CALIFORNIA FIRE CODE (CFC), PART 9, TITLE 24, C.C.R.
2013 CALIFORNIA REFERENCED STANDARDS CODE, PART 12, TITLE 24 C.C.R.
2013 NFPA-72
2013 NFPA-101
TITLE 19, CCR, PUBLIC SAFETY, STATE FIRE MARSHAL REGULATIONS



1300 Dove Street, Suite 100
Newport Beach, CA 92660
Tel: 949.698.1400 Fax: 949.698.1433

www.littleonline.com
This drawing and the design shown are the property of Little Diversified Architectural Consulting. The reproduction, copying or other use of this drawing without their written consent is prohibited and any infringement will be subject to legal action.
© Little 2016

PROJECT NAME

COMPTON
CCD

PROJECT NAME

CAMPUS PUBLIC SAFETY BUILDING
1111 EAST ARTESIA BOULEVARD,
COMPTON CALIFORNIA 90221

PROJECT NAME

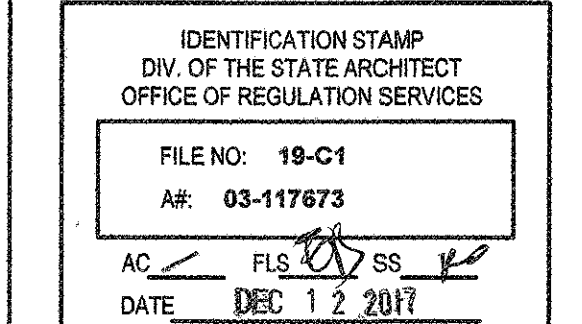

PROJECT NAME

16516
dHA + CALPEC
100 S. ARROYO PARKWAY
SUITE NO. 100
PASADENA, CA. 91306
TEL: (626) 448-8880
FAX: (626) 448-8081

PRINCIPAL IN CHARGE: KEVIN CHEN
PROJECT MANAGER:
DRAWN BY: dHA+CALPEC
NO REASON DATE



PROJECT NAME

FIRE ALARM LEGENDS & NOTES

913-4675-01

11/21/2017 FA0.1

**COMPTON
CCD**

CAMPUS PUBLIC SAFETY BUILDING

1111 EAST ARTESIA BOULEVARD,
COMPTON CALIFORNIA 90221

IDENTIFICATION STAMP
DIV. OF THE STATE ARCHITECT
OFFICE OF REGULATION SERVICES

FILE NO: 19-C1
AR: 03-117673

DATE: DEC 12 2017

16516 dHA + CALPEC
160 S. ARROYO PARKWAY
SUITE NO. 100
PASADENA, CA 91105
TEL: (626) 445-8880
FAX: (626) 445-8881

PRINCIPAL IN CHARGE
KEVIN CHEN
PROJECT MANAGER

DRAWN BY
dHA+CALPEC

NO REASON DATE



FIRE ALARM RISER DIAGRAM

913-4675-01

11/21/2017 FA0.2

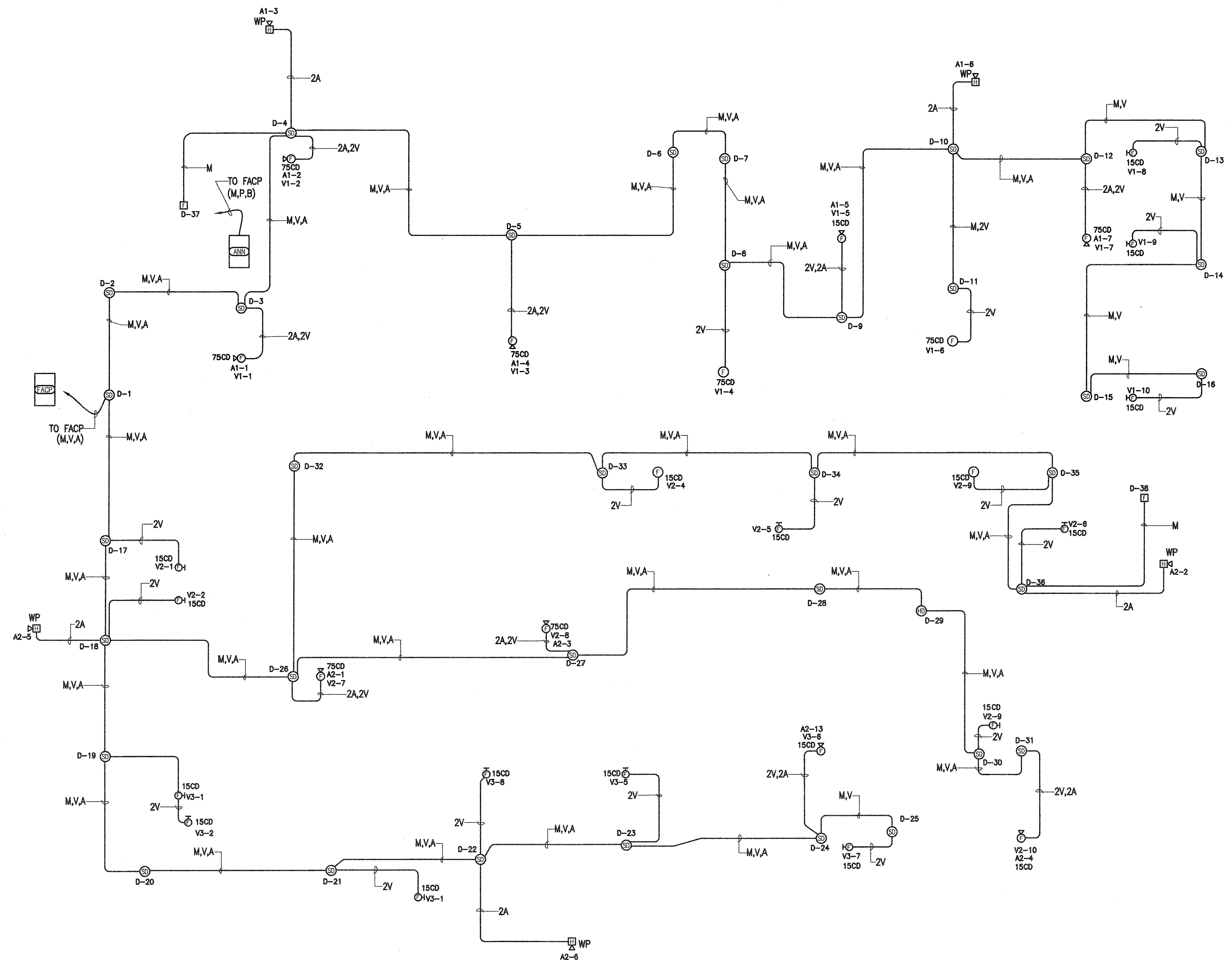

1 FIRE ALARM RISER DIAGRAM
N.T.S.

4098-9792 STANDARD SENSOR BASE

PRODUCT INFORMATION

FEATURES:

- UL LISTED, FM APPROVED
- BISEMIANALOG SENSING PROVIDES SIGNAL TRANSMISSION OF ANALOG SENSOR VALUES VIA WIRELESS OR DMX SLC TWO WIRE COMMUNICATIONS
- FIRE ALARM CONTROL PANEL PROVIDES:
- INDIVIDUAL SENSITIVITY SELECTION FOR EACH SENSOR
- SEMI-FLUSH MOUNTING ALLOWS ACCURATE ANALYSIS FOR SENSITIVITY SELECTION
- AUTOMATIC ENVIRONMENTAL COMPENSATION
- DISPLAY OF SENSITIVITY BY PERSON PER FOOT
- MULTI-STATE ALARM OPERATION
- ABILITY TO DISPLAY AND PRINT DETAILED SENSOR INFORMATION IN PLAIN ENGLISH LANGUAGE
- PHOTOELECTRIC SMOKE SENSOR 4098-9714
- SOON LEVELS OF SENSITIVITY FROM 0.5K TO 3.7K
- IONIZATION SMOKE SENSOR 4098-9717
- SOON LEVELS OF SENSITIVITY FROM 0.5K TO 1.7K
- HEAT SENSOR 4098-9733
- TEMPERATURE DETECTION IS SELECTABLE AT THE CONTROL PANEL FOR EITHER 157°F OR 207°F PER MINUTE
- TEMPERATURE SENSING IS INDEPENDENT OF RATE-OF-RISE AND PROGRAMMABLE TO OPERATE IN ANY OF TWO MODES:
- TEMPERATURE EXCEEDS IN THE RANGE FROM 32°F TO 100°F
- UL LISTED TEMPERATURE RANGE: 32°F TO 100°F
- OPERATING TEMPERATURE RANGE: 32°F TO 100°F
- RELATIVE HUMIDITY RANGE: 10% TO 95% RH
- PHOTOELECTRIC SENSOR AIR VELOCITY RANGE: 0-3000 FT/MIN
- IONIZATION SENSOR AIR VELOCITY RANGE: 0-300 FT/MIN
- WIRING CONNECTIONS SHOW TERMINALS FOR IN/OUT WIRING, #18 TO #14 AWG COMMUNICATIONS WIRING (DMX SLC), 1 AND 2 WIRE TERMINALS FOR BASE VOLTAGE (WALL/PLUG/120V SENS: 24-60VDC)

DESCRIPTION:

THE ALARM SENSOR BASES CONTAIN WIRELESS, ADDRESSABLE ELECTRONICS. THE ALARM SENSOR BASES MONITOR THE STATUS OF THE DESCRIBABLE PHOTOELECTRIC, IONIZATION, OR HEAT SENSORS. EACH SENSOR'S OUTPUT IS IDENTIFIED AND TRANSMITTED TO THE SYSTEM FIRE ALARM CONTROL PANEL (FACP) FOR SENSING. SINCE TRI-ALARM SENSORS USE THE SAME BASE, DIFFERENT SENSOR TYPES CAN BE EASILY INTERCHANGED TO MEET SPECIFIC LOCATION REQUIREMENTS. THIS FEATURE ALLOWS INTENTIONAL SENSOR SUBSTITUTION DURING BUILDING CONSTRUCTION. WHEN CONDITIONS ARE TEMPORARILY BEST, INSTEAD OF CHANGING THE SMOKE SENSORS, HEAT SENSORS MAY BE INSTALLED WITHOUT REPROGRAMMING THE CONTROL PANEL. ALTHOUGH THE CONTROL PANEL WILL INDICATE AN INCORRECT SENSOR TYPE, THE HEAT SENSOR WILL OPERATE AS A DEFAULT SENSITIVITY PROVIDING HEAT DETECTION FOR BUILDING PROTECTION AT THAT LOCATION.

WIRING:

- ALL WIRING TO COMPLY WITH LOCAL CODE.
- CONDUCTIONS MUST BE FREE OF ALL GROUNDS.
- MAINTAIN CORRECT POLARITY.
- WIRING TO DMX SLC WIRE IS 18 AWG TWISTED SHIELDED PAIR.
- SHIELD IS PRESSURE CONNECT TO THE OUTGOING DMX SLC SHIELD TO PROVIDE A CONTINUOUS SHIELD OVER THE LENGTH OF THE DMX SLC CHANNEL. METHOD OF SPlice DETERMINED BY AHJ.
- REFER TO INSTALLATION INSTRUCTIONS (574-707)
- REFER TO APPLICATION MANUAL (524-023)

FLUSH MOUNTING
(BOX TO BE FLUSH OR RECESSED 1/4" MINIMUM)

TrueAlert™ NON-ADDRESSABLE MULTI-CANDELA AUDIBLE/VISIBLE NOTIFICATION APPLIANCE (ELECTRONIC HORN W/STROBE)

PRODUCT INFORMATION

FEATURES:

- CLASS B (STYLE Y) OPERATION REQUIRES CONNECTION TO A COMPATIBLE SMARTSIC CONTROL MODULE (SCM) 4905-9938
- CLASS A (STYLE Z) OPERATION WHEN CONNECTED TO THE 4905-9938 SCM OR 41000 SERIES FIRE ALARM CONTROL PANEL NACS

SPECIFICATIONS:

- HOUSING DIMENSIONS (INCLUDING LENS): 5 1/8" H X 5" W X 2 3/4" D
- TEMPERATURE RANGE: 32°F TO 122°F (0°C TO 50°C)
- HUMIDITY RANGE: 10% TO 95% NON-CONDENSING AT 100% (30°C)
- TERMINAL BLOCKS FOR 18AWG TO 12AWG TWO WIRES PER TERMINAL FOR IN/OUT WIRING.

4905-9961 OPTIONAL WIRE GUARD (SHOWN HERE FOR REFERENCE ONLY, CAN BE USED ON OTHER MOUNTING OPTIONS)

WALL MOUNT INSTALLATION HEIGHT REFERENCE

SEMI-FLUSH MOUNTING

HORN
- SOUND OUTPUT CHARACTERISTICS: 2400 TO 3000 Hz SHEEP, MODULATED AT 120 Hz RATE

HORN SOUND OUTPUT PATTERNS 8" TO 12" (2")

VOLTAGE	18 VDC	24 VDC	33 VDC
SECOND TYPE *	STEADY	CODED	STEADY
REMEMBERANCE CHAMBER	81 DBA @ 30 DBA	84 DBA @ 30 DBA	86 DBA @ 30 DBA
MEMORANDUM	81 DBA @ 30 DBA	84 DBA @ 30 DBA	86 DBA @ 30 DBA
AMECHONIC	81 DBA @ 30 DBA	84 DBA @ 30 DBA	86 DBA @ 30 DBA

STROBE

- WAVED VOLTAGE RANGE: UL LISTED: 16 VDC TO 33 VDC PER UL 1971
- FLASH RATE: 1Hz
- SYNCRONIZED MODE NAC LOADING: MAXIMUM OF 35 SYNCRONIZED STROBES PER NAC CIRCUIT

IMPORTANT! WALL MOUNT INSTALLATION HEIGHT REFERENCE

TO ADDITIONAL NOTIFICATION APPLIANCE DEVICE OR RETURN TO FACP FOR STYLE Z APPLICATION IF LAMP COLOR ON CIRCUIT IS A STYLE Y APPLICATION PLACE A 10K 1/2W END-OF-LINE RESISTOR

TO ADDITIONAL NOTIFICATION APPLIANCE DEVICE OR RETURN TO FACP FOR STYLE Z APPLICATION IF LAMP COLOR ON CIRCUIT IS A STYLE Y APPLICATION PLACE A 10K 1/2W END-OF-LINE RESISTOR

4099-9021 SINGLE ACTION NO GRIP IDNet SLC ADDRESSABLE MANUAL STATION

PRODUCT INFORMATION

FEATURES:

- UL LISTED
- SINGLE ACTION NO GRIP, IDNet SLC ADDRESSABLE
- PULL LEVER PROTRUSIVE WHEN ARMED
- LED INDICATOR FLASHES DURING COMMUNICATION
- TEMPERATURE RESISTANT KEY LOCK
- MOUNTING: SEMI-FLUSH SURFACE
- OPERATING TEMPERATURE RANGE: 32°F TO 122°F
- RELATIVE HUMIDITY RANGE: 0 - 95% RH
- ADAPTER PLATES 2999-9013 OR 2099-9014 CAN BE USED FOR RETREAT APPLICATIONS
- 5" HIGH X 3 3/4" WIDE X 1 1/2" DEEP
- SCREEN TERMINALS FOR 18 TO 14 AWG WIRE
- ADDRESSABLE BY MEANS OF A 4 PIN POSITION DIP SWITCH
- COMPATIBLE WITH DMX SLC/ANALOG

OPERATION:

4099-9021 NO GRIP SINGLE ACTION STATION PROVIDES A MORE EASILY ACTIVATED PULL LEVER FOR INDIVIDUAL USERS WHO FIND THE REMOVED STATION LEVER DIFFICULT TO ACTIVATE. COMPLETING THIS ACTION BREAKS AN INTERNAL PULL LEVER AND THAT IS VISIBLE BELOW THE PULL LEVER. USE OF PLASTIC ROD IS OPTIONAL, THE PULL LEVER MOVES INTO THE ALARM POSITION AND REMAINS EXTENDED OUT OF THE MOUNTING TO PROVIDE A VISIBLE INDICATION.

RESETTING:

4099-9021 SINGLE ACTION STATION REQUIRES A KEY TO RESET THE ACTIVATION LEVER AND DEACTIVATE THE ALARM SWITCH (IF OPTIONAL PLASTIC BREAK ROD WAS USED IT MUST BE REPLACED)

CONSTRUCTION:

STATION HOUSING AND PULL LEVER ARE CONSTRUCTED OF CHP RESISTANT AND DIRT RESISTANT, HIGH IMPACT LEXAN. HOUSING IS RED WITH BASED WHITE LETTERING AND PULL LEVER IS WHITE WITH RED BASED LETTERING.

LEDAIN IS A REGISTERED TRADEMARK OF THE GENERAL ELECTRIC CO.

APPLICATION:

FULL STATIONS SHALL BE INSTALLED IN ACCORDANCE WITH NFPA 72 AND ADA GUIDE LINES.

INTRODUCTION:

THE 4099-9021 ADDRESSABLE PULL STATION PROVIDES TWO-STATE STATUS INFORMATION (NORMAL AND SHIRT) TO THE IDNet SLC COMPATIBLE FIRE ALARM CONTROL PANEL (FACP) ON THE DMX SLC CHANNEL. THE DMX SLC CHANNEL PROVIDES THE COMMUNICATION LINE BETWEEN PULL STATION AND THE FACP AND POWERS THE ENTIRE CIRCUIT.

WIRING:

- ALL WIRING TO COMPLY WITH LOCAL CODE.
- CONDUCTIONS MUST BE FREE OF ALL GROUNDS.
- MAINTAIN CORRECT POLARITY.
- DMX SLC LINES ARE TO BE 18 AWG TWISTED SHIELDED PAIR
- MAXIMUM LINE RUN FROM PANEL TO FAREST DEVICE NOT TO EXCEED 2000 FEET
- MAXIMUM TOTAL WIRE (INCLUDING ALL T-TAPS) FROM PANEL NOT TO EXCEED 10,000 FEET
- MAXIMUM QUANTITY OF DEVICES PER CIRCUIT: 250
- TERMINALS 1 AND 2 FOR FIELD WIRING, TERMINALS 3 AND 4 ARE FACTORY WIRING
- WIRE WIRE, SOLDER, OR SOLDER THE SHIELD WIRES.
- IF SHIELD IS PRESENT, IT SHOULD BE CONNECTED TO THE OUTGOING DMX SLC SHIELD TO PROVIDE A CONTINUOUS SHIELD OVER THE LENGTH OF THE DMX SLC CHANNEL. SHIELD SHOULD BE INSULATED FROM THE ELECTRICAL BOX.
- SEE INSTALLATION INSTRUCTIONS 574-332

FLUSH MOUNTING

SEMI-FLUSH MOUNTING

CUTOUT MUST BE A MINIMUM 4" HIGH BY 5" WIDE

TO ADDITIONAL NOTIFICATION APPLIANCE DEVICE OR RETURN TO FACP FOR STYLE Z APPLICATION IF LAMP COLOR ON CIRCUIT IS A STYLE Y APPLICATION PLACE A 10K 1/2W END-OF-LINE RESISTOR

TrueAlert™ NON-ADDRESSABLE MULTI-CANDELA VISIBLE NOTIFICATION APPLIANCE (WALL MOUNT)

PRODUCT INFORMATION

FEATURES:

- ADA COMPLIANT
- SYNCHRONIZATION FLASH RATE MODE FOR USE WITH:
- SEPARATE STROBE SYNCHRONIZATION MODULES THAT ARE AVAILABLE FOR CLASS B OR CLASS A OPERATION
- SEPARATE SMARTSIC CONTROL MODULES (SCM) THAT PROVIDE CLASS B OR CLASS A OUTPUT FROM CONVENTIONAL NAC INPUTS

SPECIFICATIONS:

- HOUSING DIMENSIONS: 5-1/8" H X 5" W X 2-3/4" D (130mm X 127mm X 70mm)
- TEMPERATURE RANGE: 32°F TO 122°F (0°C TO 50°C)
- HUMIDITY RANGE: 10% TO 95% NON-CONDENSING AT 100% (30°C)
- TERMINAL BLOCKS FOR 18AWG TO 12AWG TWO WIRES PER TERMINAL FOR IN/OUT WIRING.

4905-9961 OPTIONAL WIRE GUARD (SHOWN HERE FOR REFERENCE ONLY, CAN BE USED ON OTHER MOUNTING OPTIONS)

WALL MOUNT INSTALLATION HEIGHT REFERENCE

SEMI-FLUSH MOUNTING

STROBE:

- WAVED VOLTAGE RANGE: UL LISTED: 16 VDC TO 33 VDC PER UL 1971
- UL LISTED: 20 VDC TO 30 VDC PER IAC 5228-4678
- FLASH RATE: 1Hz
- SYNCHRONIZED MODE NAC LOADING: MAXIMUM OF 35 SYNCRONIZED STROBES PER NAC CIRCUIT
- CURRENT DRAWING REFLECTS STROBE FLASHING

IMPORTANT! WALL MOUNT INSTALLATION HEIGHT REFERENCE

TO ADDITIONAL NOTIFICATION APPLIANCE DEVICE OR RETURN TO FACP FOR STYLE Z APPLICATION IF LAMP COLOR ON CIRCUIT IS A STYLE Y APPLICATION PLACE A 10K 1/2W END-OF-LINE RESISTOR

TO ADDITIONAL NOTIFICATION APPLIANCE DEVICE OR RETURN TO FACP FOR STYLE Z APPLICATION IF LAMP COLOR ON CIRCUIT IS A STYLE Y APPLICATION PLACE A 10K 1/2W END-OF-LINE RESISTOR

TrueAlert™ NON-ADDRESSABLE MULTI-CANDELA AUDIBLE/VISIBLE NOTIFICATION APPLIANCE WEATHERPROOF

PRODUCT INFORMATION

FEATURES:

- UL LISTED TO STANDARD 1971 FOR INDOOR APPLICATIONS
- WITH RELEASABLE STROBE INTENSITY SETTINGS
- UL LISTED TO STANDARD 1638 FOR OUTDOOR APPLICATIONS
- UL LISTED TO STANDARD 494
- INDOOR APPLICATIONS ARE ADA COMPLIANT

SYNCHRONIZATION FLASH RATE MODE FOR USE WITH:

- SEPARATE STROBE SYNCHRONIZATION MODULES THAT ARE AVAILABLE FOR CLASS B OR CLASS A OPERATION
- SEPARATE SMARTSIC CONTROL MODULES (SCM) THAT PROVIDE CLASS B OR CLASS A OUTPUT FROM CONVENTIONAL NAC INPUTS

SPECIFICATIONS:

- HOUSING DIMENSIONS: 5-1/8" H X 5" W X 2-3/4" D (130mm X 127mm X 70mm)
- UL 1971 LISTED TEMPERATURE RANGE: 32°F TO 122°F (0°C TO 50°C)
- UL 1638 LISTED TEMPERATURE RANGE: -31°F TO 150°F (-35°C TO 66°C)
- UL 494 LISTED TEMPERATURE RANGE: 32°F TO 122°F (0°C TO 50°C)
- UL 1971 LISTED HUMIDITY RANGE: 10% TO 95% NON-CONDENSING AT 100% (30°C)
- UL 1638 LISTED HUMIDITY RANGE: UP TO 95% AT 100°F (40°C)
- TERMINAL BLOCKS FOR 18AWG TO 12AWG TWO WIRES PER TERMINAL FOR IN/OUT WIRING.

WIRING:

- NOTIFICATION APPLIANCES ARE RATED PER INDIVIDUAL MANUFACTURE LABEL.
- MAINTAIN CORRECT POLARITY ON TERMINAL CONNECTIONS, DO NOT LOOP WIRES UNDER TERMINALS.
- ALL NAC WIRING CONNECTIONS ARE SUPERSEDED AND POWER-LIMITED.
- SEE INSTALLATION INSTRUCTIONS (579-857) FOR ADDITIONAL INFORMATION.

WALL MOUNT INSTALLATION HEIGHT REFERENCE

TO ADDITIONAL NOTIFICATION APPLIANCE DEVICE OR RETURN TO FACP FOR STYLE Z APPLICATION IF LAMP COLOR ON CIRCUIT IS A STYLE Y APPLICATION PLACE A 10K 1/2W END-OF-LINE RESISTOR

TO ADDITIONAL NOTIFICATION APPLIANCE DEVICE OR RETURN TO FACP FOR STYLE Z APPLICATION IF LAMP COLOR ON CIRCUIT IS A STYLE Y APPLICATION PLACE A 10K 1/2W END-OF-LINE RESISTOR

LITTLE
DIVERIFIED ARCHITECTURAL CONSULTING

1300 Dove Street, Suite 100
Newport Beach, CA 92660
T: 949.698.1400 F: 949.698.1433

www.littleonline.com

This drawing and the design shown are the property of Little Diverified Architectural Consulting. The reproduction, copying or other use of this drawing without their written consent is prohibited and any infringement will be subject to legal action.

© Little 2015

COMPTON
CCD

CAMPUS PUBLIC SAFETY BUILDING
1111 EAST ARTESIA BOULEVARD,
COMPTON CALIFORNIA 90221

IDENTIFICATION STAMP
DIV. OF THE STATE ARCHITECT
OFFICE OF REGULATION SERVICES

FILE NO: 19-C1
AR: 03-117673
DATE: DEC 17 2017

16516 dHA + CALPEC
160 S. ARROYO PARKWAY
SUITE 100
PALMDALE, CA 91306
TEL: (626) 445-8580
FAX: (626) 445-8081

PRINCIPAL IN CHARGE
KEVIN CHEN
PROJECT MANAGER

DRAWN BY
dHA+CALPEC

NO REASON DATE

REGISTERED PROFESSIONAL ENGINEER
NUMBER N. 1100
E-1384
C-1579
STATE OF CALIFORNIA

FIRE ALARM DETAILS

913-4675-01

11/21/16 FA0.3

TrueAlert™ NON-ADDRESSABLE MULTI-CANDELA AUDIBLE/VISIBLE NOTIFICATION APPLIANCE

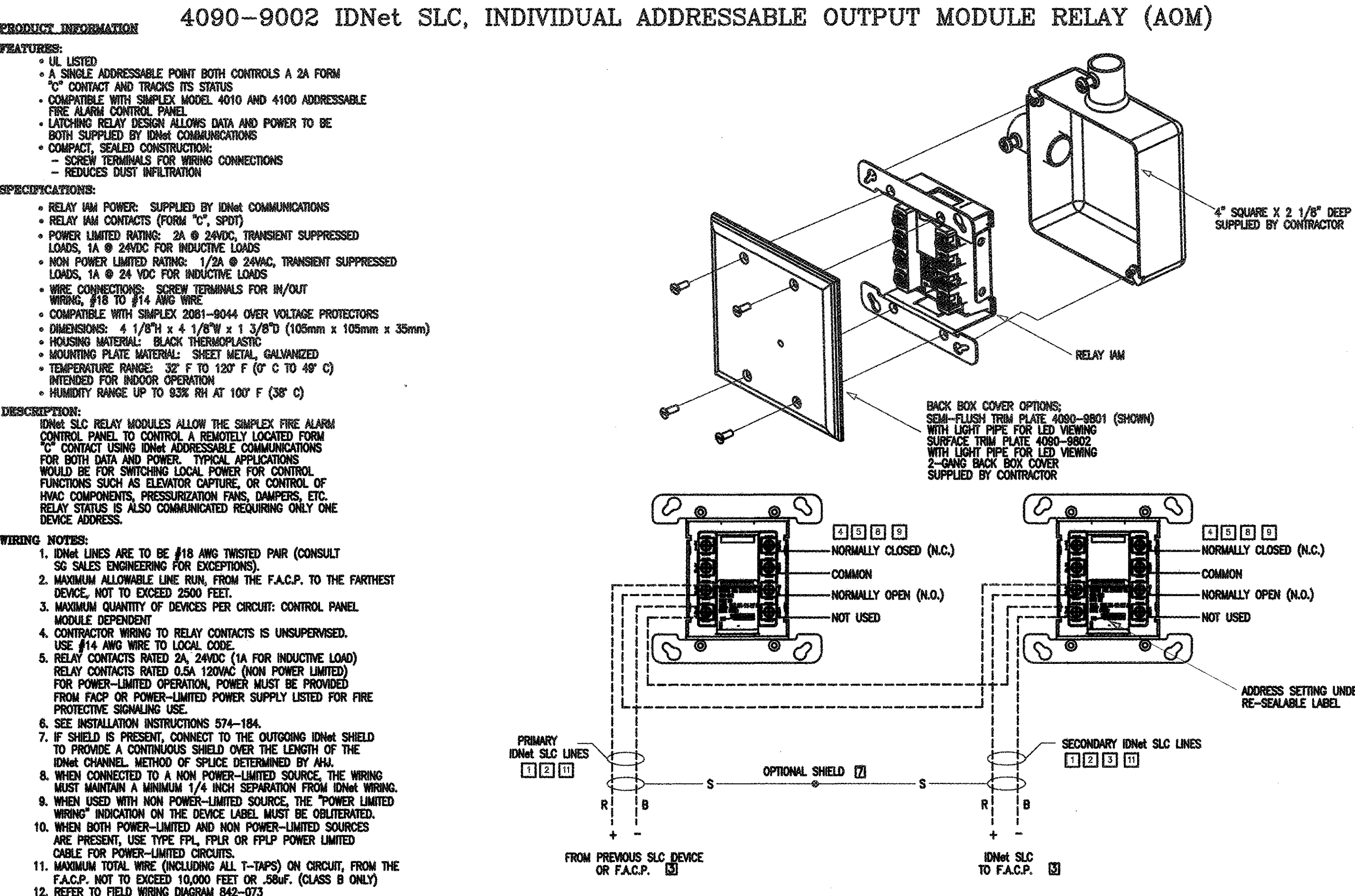
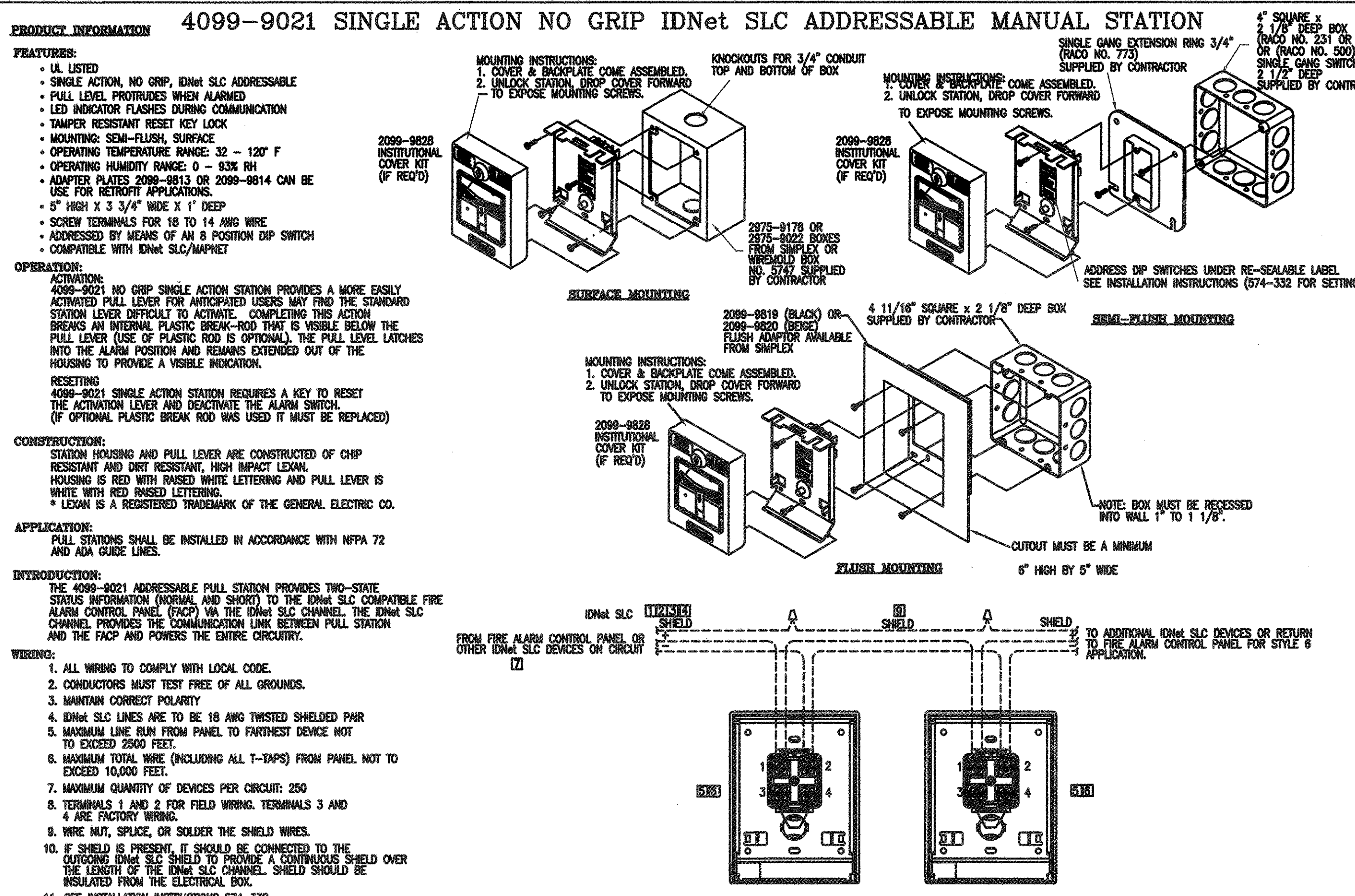
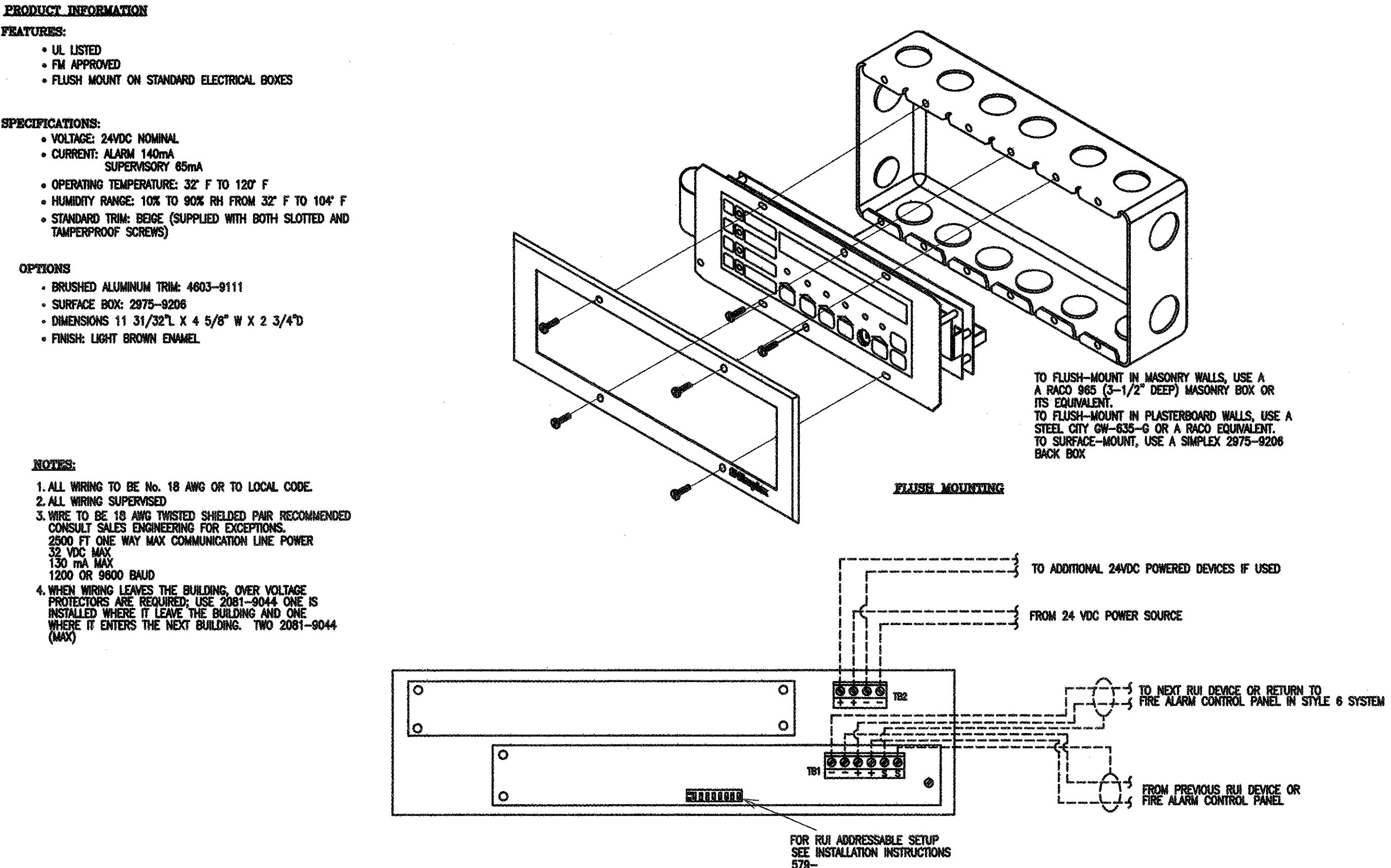
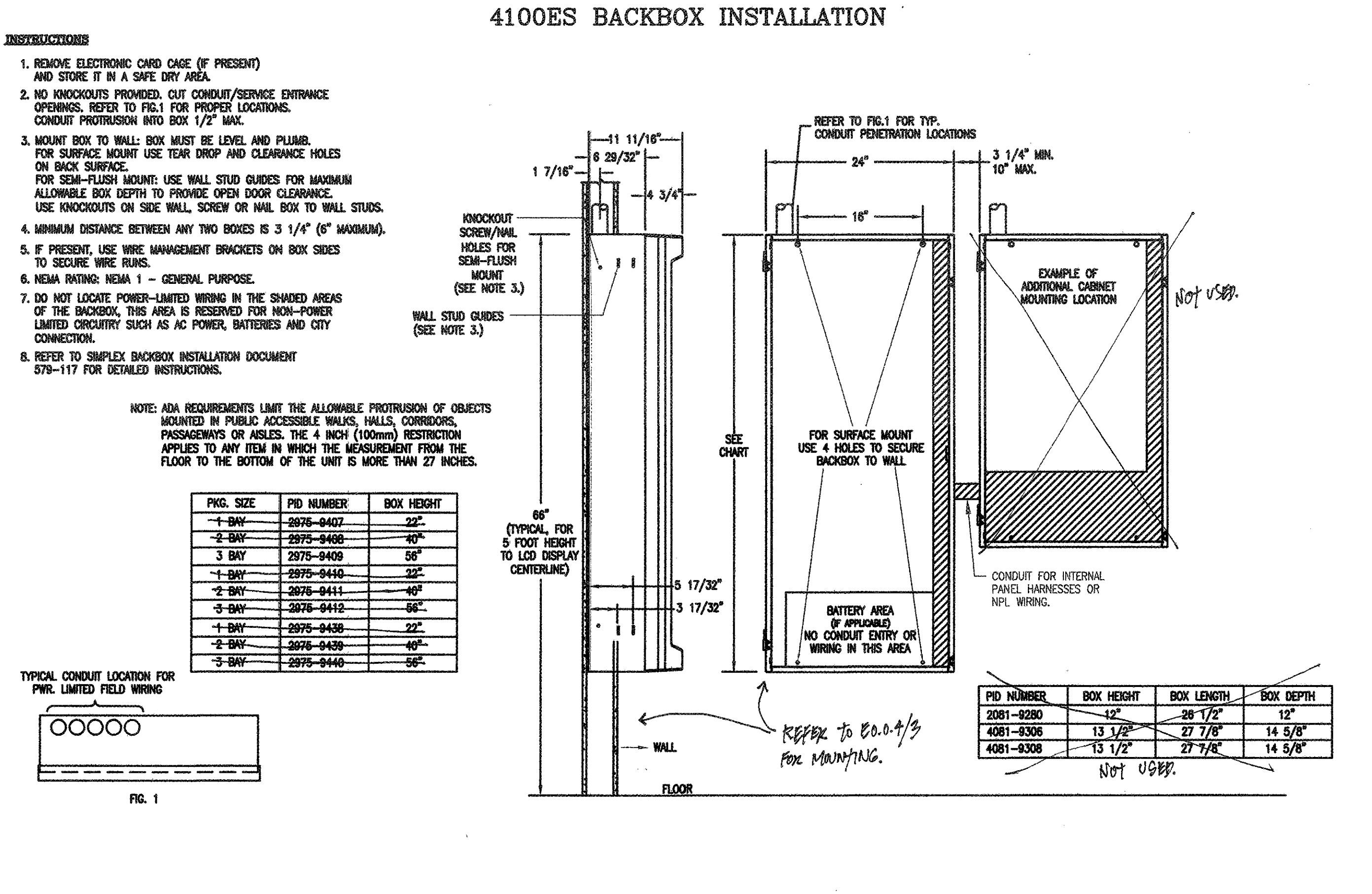
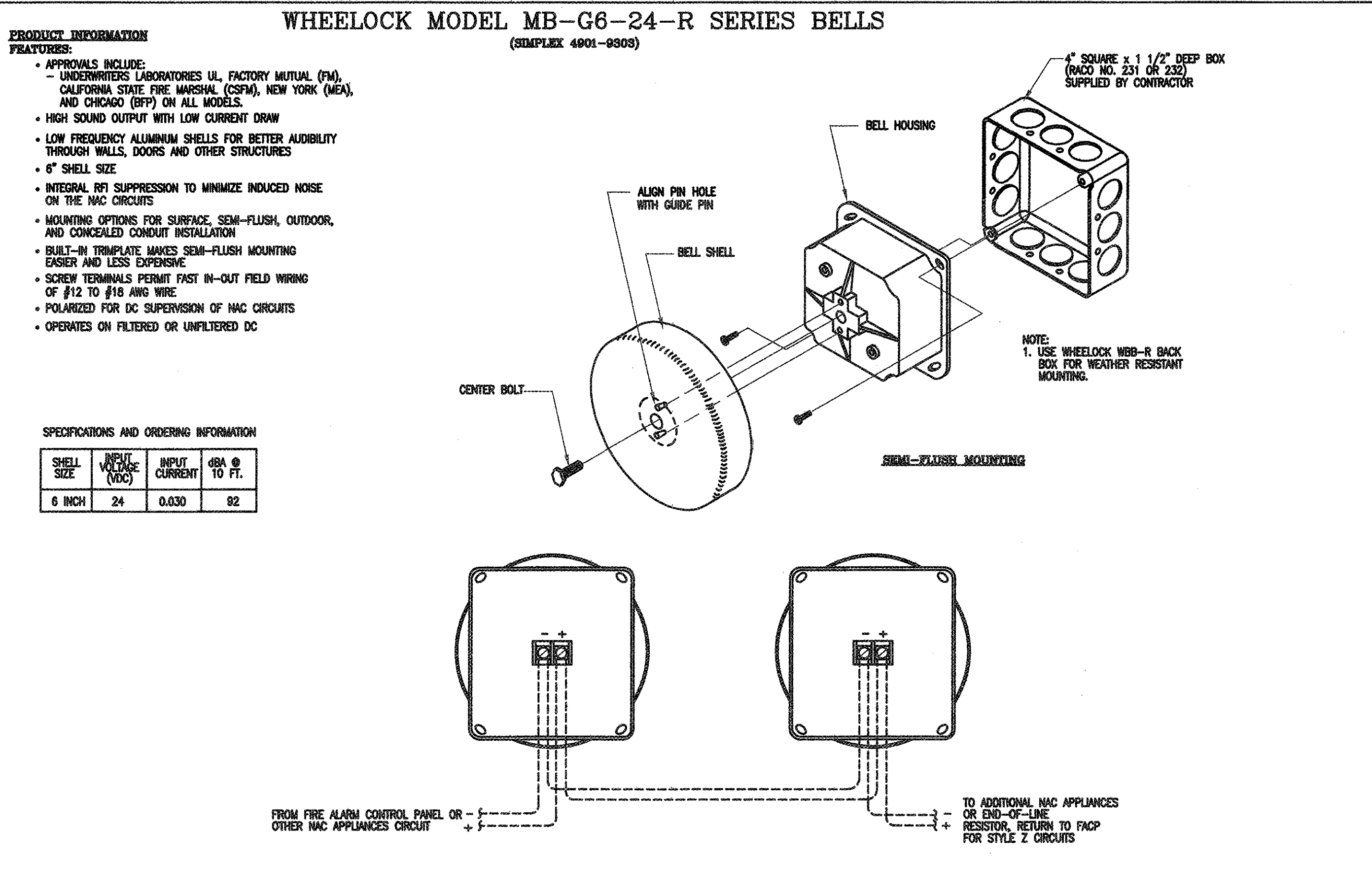
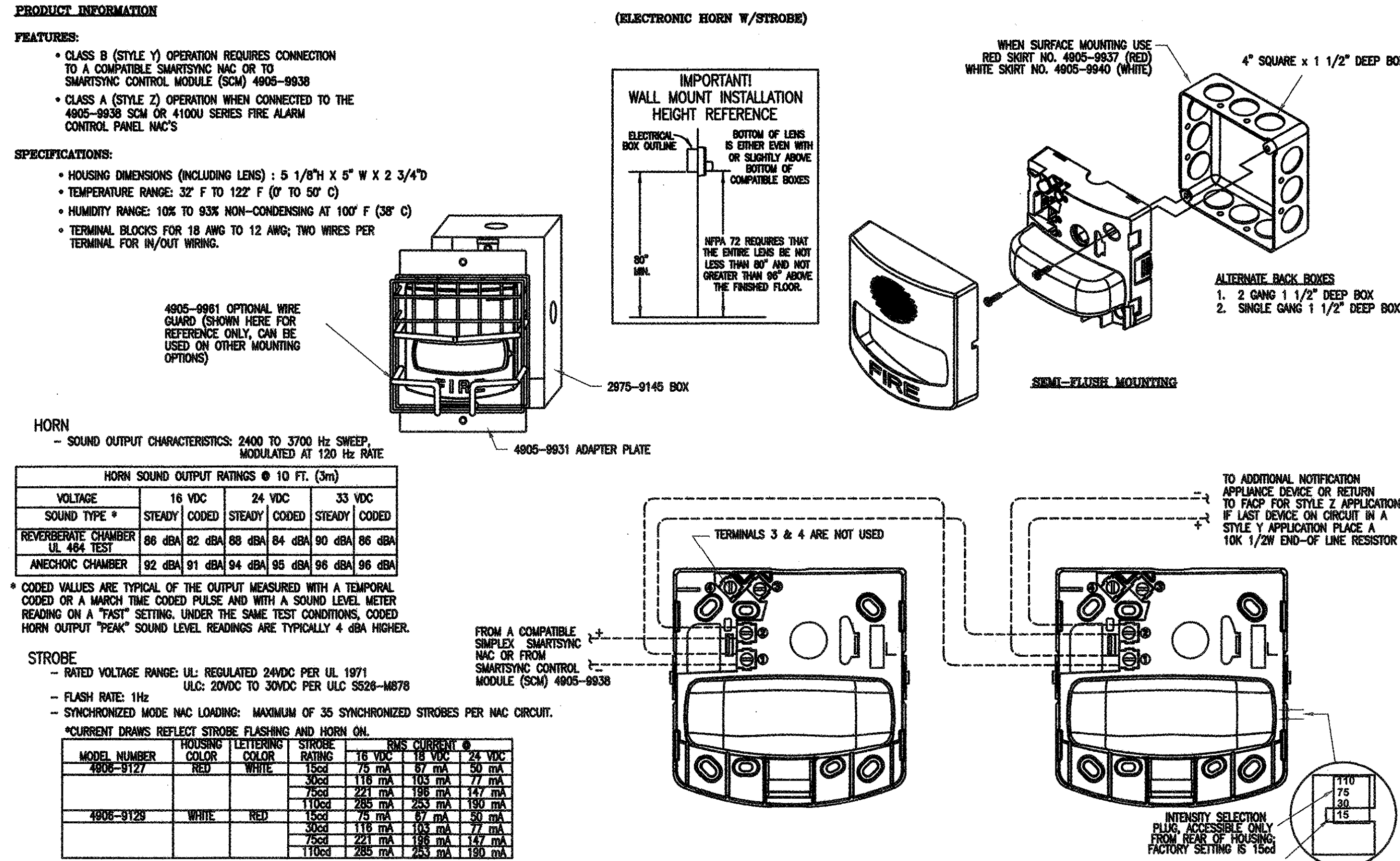

LITTLE
DIVERSIFIED ARCHITECTURAL CONSULTING

1300 Dove Street, Suite 100
Newport Beach, CA 92660
T: 949.698.1400 F: 949.698.1433

www.littleonline.com

This drawing and the design shown are the property of Little Diversified Architectural Consulting. The reproduction, copying or other use of this drawing without their written consent is prohibited and any infringement will be subject to legal action.

© Little 2016

COMPTON
CCD

CAMPUS PUBLIC SAFETY BUILDING

1111 EAST ARTESIA BOULEVARD,
COMPTON CALIFORNIA 90221

IDENTIFICATION STAMP
DIV. OF THE STATE ARCHITECT
OFFICE OF REGULATION SERVICES

FILE NO: 19-C1
Ar: 03-117873

AC: PLS: SS: [Signature]
DATE: DEC 1 2 2017

16516 dHA + CALPEC

150 S. ARBOTO PARKWAY
SUITE 100
PASADENA, CA 91305
TEL: (626) 445-8850
FAX: (626) 445-8881

PRINCIPAL IN CHARGE
KEVIN CHEN

PROJECT MANAGER

DRAWN BY
dHA+CALPEC

NO REASON DATE

FIRE ALARM DETAILS

913-4675-01

11/21/2017 FA0.3.1

PRODUCT INFORMATION

2098-9806 REMOTE ALARM INDICATOR/KEY SWITCH

- FEATURES:**
- UL LISTED
 - CALIFORNIA STATE FIRE MARSHAL LISTING NUMBERS: 2098-9806 ALARM INDICATOR 7300-0026150
 - MOUNTING: FLUSH
 - FINISH: CHROME OR STAINLESS STEEL

- SPECIFICATIONS:**
- ALARM CURRENT: 2.8 mA
 - DIMENSIONS OF BOX: 2" W X 3 1/4" X 2 1/2"

DESCRIPTION:

2098-9806 REMOTE TEST STATION PROVIDES A REMOTE RED ALARM LED STATUS INDICATOR AND A REMOTE TEST KEY ACTIVATED SWITCH MOUNTED ON A SINGLE GANG STAINLESS STEEL PLATE. THE LED WILL PULSE TO INDICATE NORMAL OPERATION OF THE DETECTOR AND WILL ENERGIZE CONTINUOUS WHEN IN ALARM OR IN TROUBLE. (THE EXACT STATUS OF THE SENSOR WILL BE DISPLAYED AT THE FIRE ALARM CONTROL PANEL.) TURNING THE TEST SWITCH TO "TEST" WILL INITIATE AN ALARM AND ALLOW THE RESULTING SYSTEM RESPONSES TO BE VERIFIED.

- WIRING:**
- MINIMUM 18 AWG OR TO LOCAL CODE
 - CONDUCTORS MUST TEST FREE OF ALL GROUNDS.
 - REMOTE ALARM LED IS POLARIZED, OBSERVE COLOR CODED WIRING.
 - ONE INDICATOR MAY BE INSTALLED PER DETECTOR.

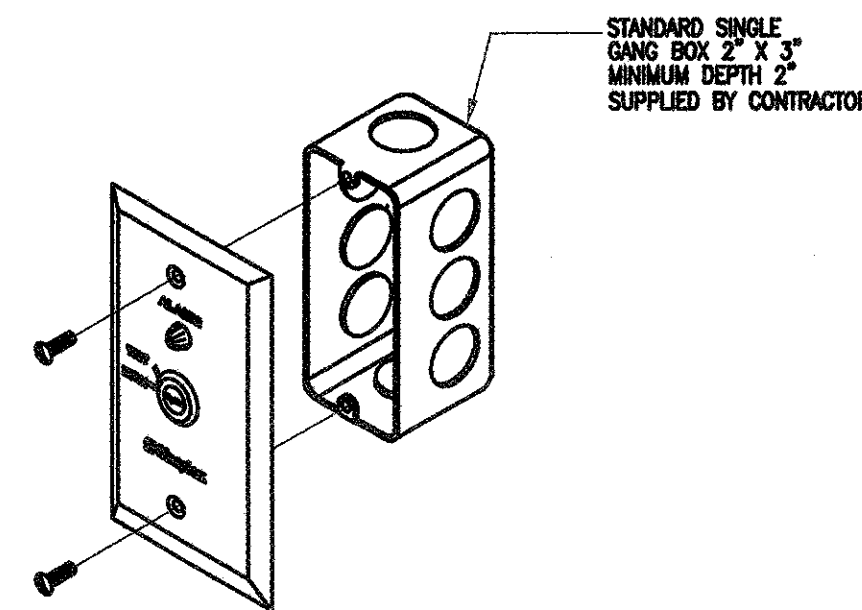

FLUSH MOUNTING

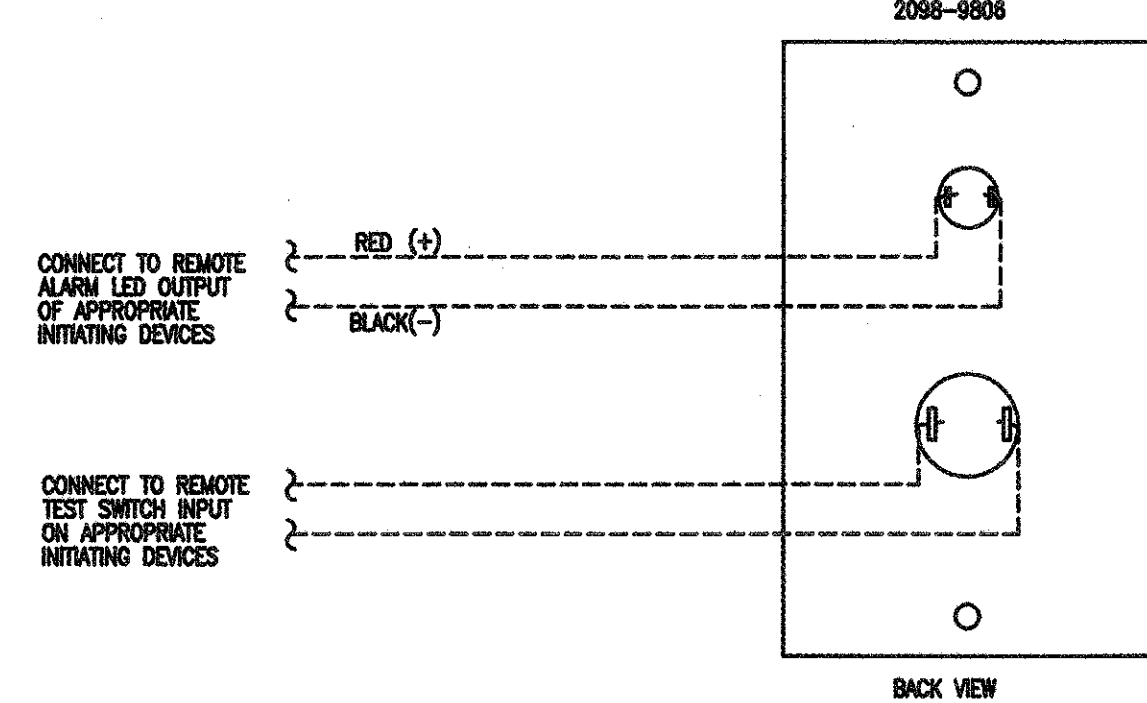

PRODUCT INFORMATION

AIR PRODUCTS MR-101/C SPDT CONTROL RELAY

(SIMPLEX 2088-9000)

- FEATURES:**
- UL LISTED
 - MULTIPLE COIL VOLTAGE INPUTS, DIODE POLARIZED
 - SPDT CONTACTS
 - RELAY STATUS LED
 - METAL ENCLOSURES WITH LED VIEWING PORT
 - MOUNTING: WALL SURFACE

- SPECIFICATIONS:**
- COIL REQUIREMENT: 0.0154 @ 10-30VDC/VAC, 115VAC, 230VAC
 - CONTACT RATING: 10.0A @ 115VAC
 - TERMINAL BLOCK RATING: UP TO #14AWG
 - TEMPERATURE RANGE: -80°F TO +180°F (-50°C TO 80°C)
 - 15-35 VDC OR VAC, 115VAC OR 230VAC BY WIRING TO APPROPRIATE INPUT TERMINALS. EACH RELAY CONTAINS A RED LED WHICH INDICATES THE RELAY COIL IS ENERGIZED. THESE DEVICES ARE IDEAL FOR APPLICATIONS WHERE LOCAL CONTACTS ARE REQUIRED FOR SYSTEM STATUS, REMOTE CONTACTS FOR CONTROL OF ELECTRICAL LOADS AND GENERAL PURPOSE SWITCHING.
 - DIMENSIONS (METAL ENCLOSURE): 6-1/8" H X 3-1/4" W X 2-1/2" D (155.78mm H X 82.55mm W X 63.5mm D)

DESCRIPTION:

THE MR-101/C CONTROL RELAY OFFERS SPDT 10 AMP CONTACT WHICH MAY BE OPERATED BY ONE OF FOUR INPUT VOLTAGES. A SINGLE RELAY MAY BE ENERGIZED FROM A VOLTAGE SOURCE OF 15-35 VDC OR VAC, 115VAC OR 230VAC BY WIRING TO APPROPRIATE INPUT TERMINALS. EACH RELAY CONTAINS A RED LED WHICH INDICATES THE RELAY COIL IS ENERGIZED. THESE DEVICES ARE IDEAL FOR APPLICATIONS WHERE LOCAL CONTACTS ARE REQUIRED FOR SYSTEM STATUS, REMOTE CONTACTS FOR CONTROL OF ELECTRICAL LOADS AND GENERAL PURPOSE SWITCHING.

- WIRING:**
- ALL WIRING TO COMPLY WITH LOCAL CODE.
 - MAINTAIN CORRECT POLARITY.
 - CONDUCTORS MUST TEST FREE OF ALL GROUNDS.

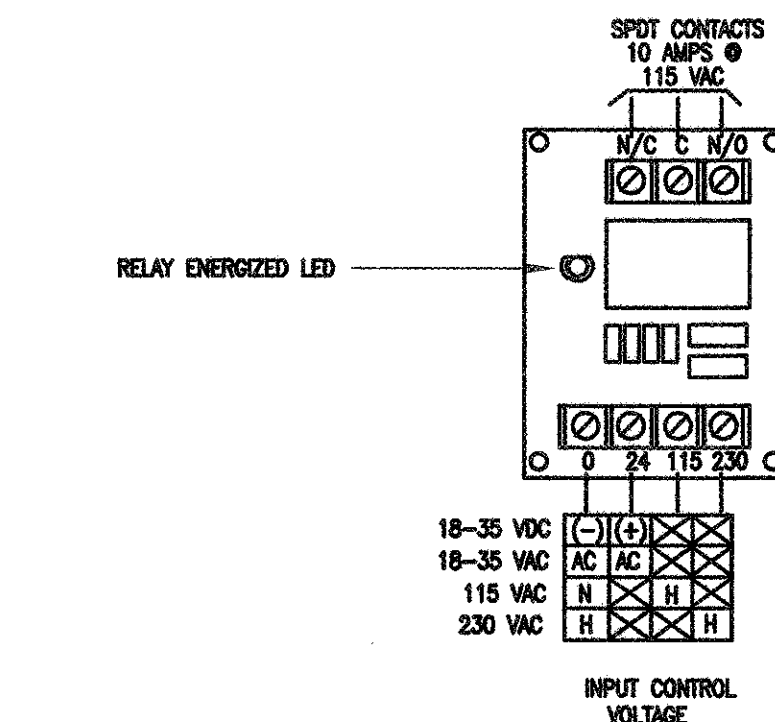
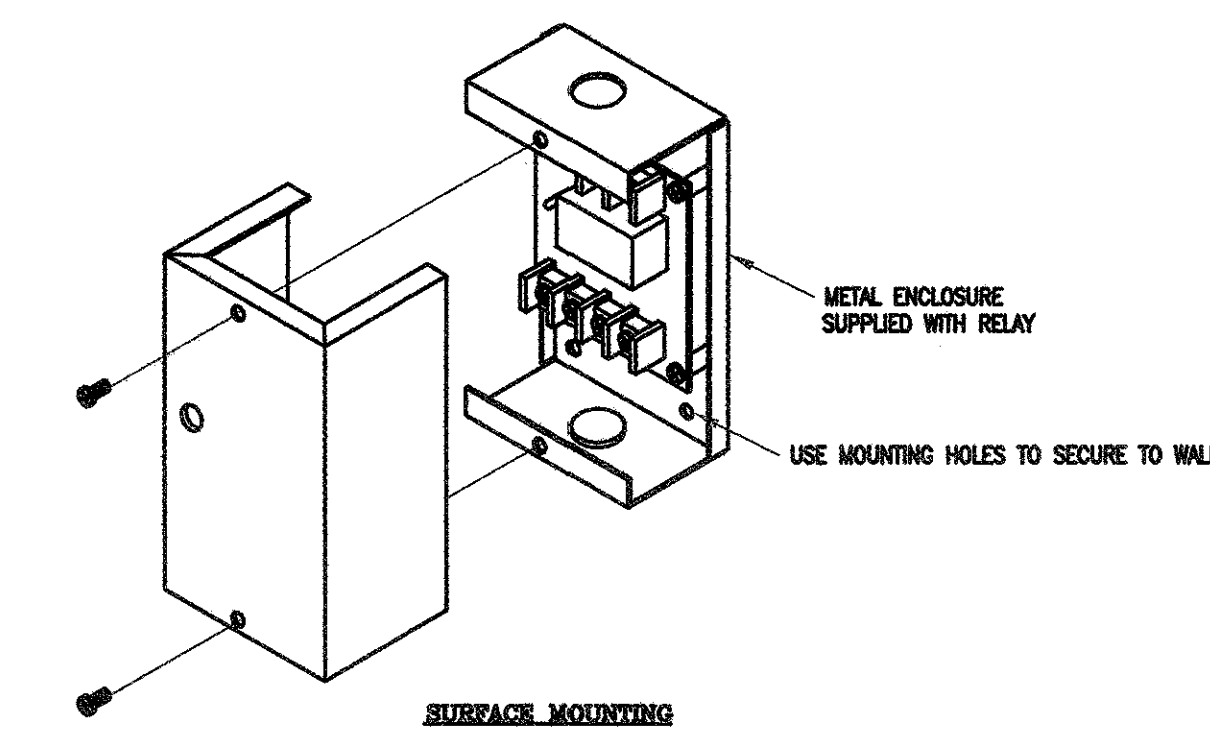

TrueAlert™ NON-ADDRESSABLE MULTI-CANDELA VISIBLE NOTIFICATION APPLIANCE

(CEILING MOUNT)

- FEATURES:**
- UL LISTED TO STANDARD 1971
 - ADA COMPLIANT
 - SYNCHRONIZATION FLASH RATE MODE FOR USE WITH SEPARATE STROBE SYNCHRONIZATION MODULES THAT ARE AVAILABLE FOR CLASS B OR CLASS A OPERATION
 - SEPARATE SMARTSYNC CONTROL MODULES (SCM) THAT PROVIDE CLASS B OR CLASS A OUTPUT FROM CONVENTIONAL IMC INPUTS

- SPECIFICATIONS:**
- HOUSING DIMENSIONS: 4-3/4" L X 2-5/16" W X 2-5/8" D (121mm X 75mm X 67mm)
 - TEMPERATURE RANGE: 32°F TO 122°F (0 TO 50°C)
 - HUMIDITY RANGE: 10% TO 83% NON-CONDENSING AT 100°F (38°C)
 - TERMINAL BLOCKS FOR 18 AWG TO 12 AWG, TWO WIRES PER TERMINAL FOR IN/OUT WIRING.

- WIRING NOTES:**
- NOTIFICATION APPLIANCES ARE RATED PER INDIVIDUAL NAMEPLATE LABEL.
 - MAINTAIN CORRECT POLARITY ON TERMINAL CONNECTIONS. DO NOT LOOP WIRES UNDER TERMINALS.
 - ALL IMC WIRING CONNECTIONS ARE SUPERSEDED AND POWER-LIMITED.
 - SEE INSTALLATION INSTRUCTIONS (579-548) FOR ADDITIONAL INFORMATION.

- STROBES:**
- RATED VOLTAGE RANGE: UL LISTED: 16 VDC TO 33 VDC PER UL 1971
 - ULC LISTED: 20 VDC TO 30 VDC PER ULC S208-4678
 - FLASH RATE: 1Hz
 - SYNCHRONIZED MODE IMC LOADING: MAXIMUM OF 35 SYNCHRONIZED STROBES PER IMC CIRCUIT.

*CURRENT DRAWS REFLECT STROBE FLASHING AND HORN ON.

MODEL NUMBER	HOUSING LETTERING	STROBE COLOR	STROBE RATING	16 VDC	24 VDC	33 VDC
4905-9102	RED	WHITE	1000	86 mA	75 mA	59 mA
			2000	172 mA	149 mA	117 mA
			3000	258 mA	224 mA	175 mA
4905-9104	WHITE	RED	1000	86 mA	75 mA	59 mA
			2000	172 mA	149 mA	117 mA
			3000	258 mA	224 mA	175 mA

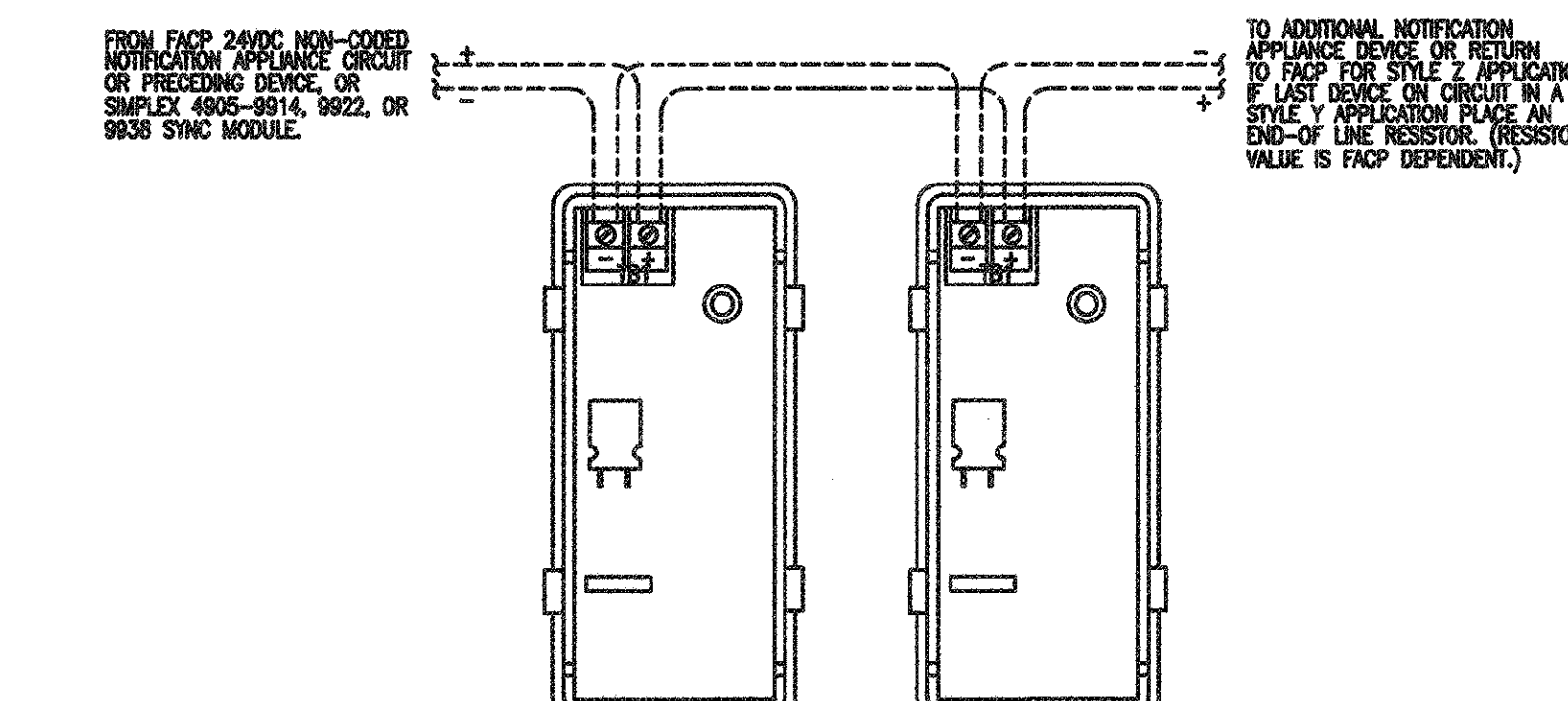
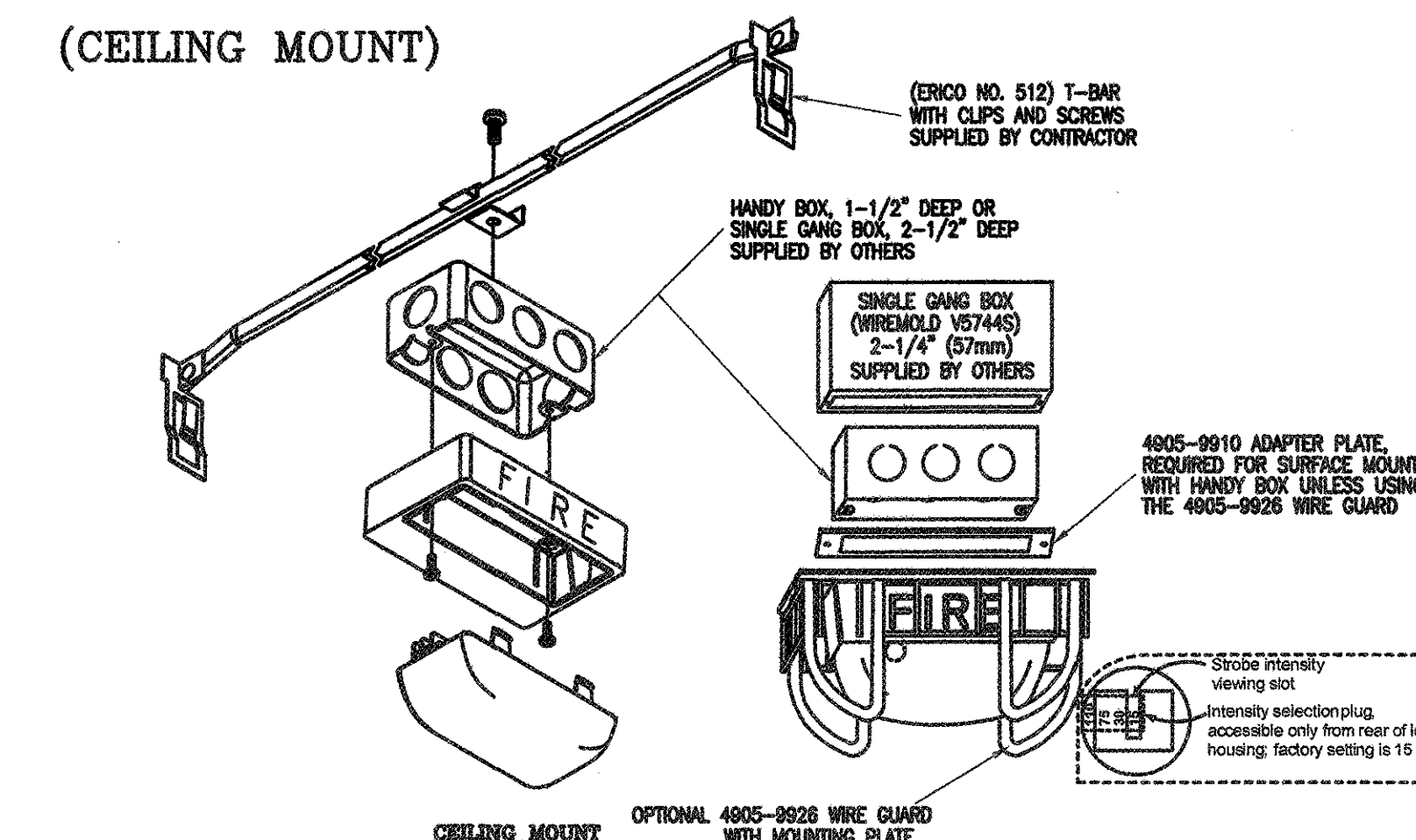

TrueAlert™ NON-ADDRESSABLE MULTI-CANDELA AUDIBLE/VISIBLE NOTIFICATION APPLIANCE

(CEILING MOUNT)

- FEATURES:**
- CLASS B (STYLE 1) OPERATION REQUIRES CONNECTION TO A COMPATIBLE SMARTSYNC IMC OR TO SMARTSYNC CONTROL MODULE (SCM) 4905-9938
 - CLASS A (STYLE 2) OPERATION WHEN CONNECTED TO THE 4905-9938 SCM OR 4100 SERIES FIRE ALARM CONTROL PANEL IMC'S

- SPECIFICATIONS:**
- HOUSING DIMENSIONS (INCLUDING LENS): 4-3/4" L X 6-7/8" W X 2-5/8" D
 - TEMPERATURE RANGE: 32°F TO 122°F (0 TO 50°C)
 - HUMIDITY RANGE: 10% TO 83% NON-CONDENSING AT 100°F (38°C)
 - TERMINAL BLOCKS FOR 18 AWG TO 12 AWG, TWO WIRES PER TERMINAL FOR IN/OUT WIRING.

- STROBES:**
- RATED VOLTAGE RANGE: UL: 16 VDC TO 33 VDC PER UL 1971
 - ULC: 20VDC TO 30VDC PER ULC S208-4678
 - FLASH RATE: 1Hz
 - SYNCHRONIZED MODE IMC LOADING: MAXIMUM OF 35 SYNCHRONIZED STROBES PER IMC CIRCUIT.

*CURRENT DRAWS REFLECT STROBE FLASHING AND HORN ON.

MODEL NUMBER	HOUSING LETTERING	STROBE COLOR	STROBE RATING	16 VDC	24 VDC	33 VDC
4905-9126	RED	WHITE	1000	86 mA	75 mA	59 mA
			2000	172 mA	149 mA	117 mA
			3000	258 mA	224 mA	175 mA
4905-9130	WHITE	RED	1000	86 mA	75 mA	59 mA
			2000	172 mA	149 mA	117 mA
			3000	258 mA	224 mA	175 mA

- HORN**
- SOUND OUTPUT CHARACTERISTICS: 2400 TO 3700 Hz SWEEP, MODULATED AT 120 Hz RATE

HORN SOUND OUTPUT RATINGS @ 10 FT. (3m)			
VOLTAGE	16 VDC	24 VDC	33 VDC
SOUND TYPE *	STEADY	CODED	STEADY
REVERBERATE CHAMBER	86 dBA	82 dBA	88 dBA
UL 484 TEST	84 dBA	80 dBA	86 dBA
ANEOCHOR CHAMBER	82 dBA	81 dBA	84 dBA
	84 dBA	84 dBA	86 dBA

* CODED VALUES ARE TYPICAL OF THE OUTPUT MEASURED WITH A TEMPORAL CODED OR A MARCH TIME CODED PULSE AND WITH A SOUND LEVEL METER READING ON A "FAST" SETTING UNDER THE SAME TEST CONDITIONS. CODED HORN OUTPUT "PEAK" SOUND LEVEL READINGS ARE TYPICALLY 4 dBA HIGHER.

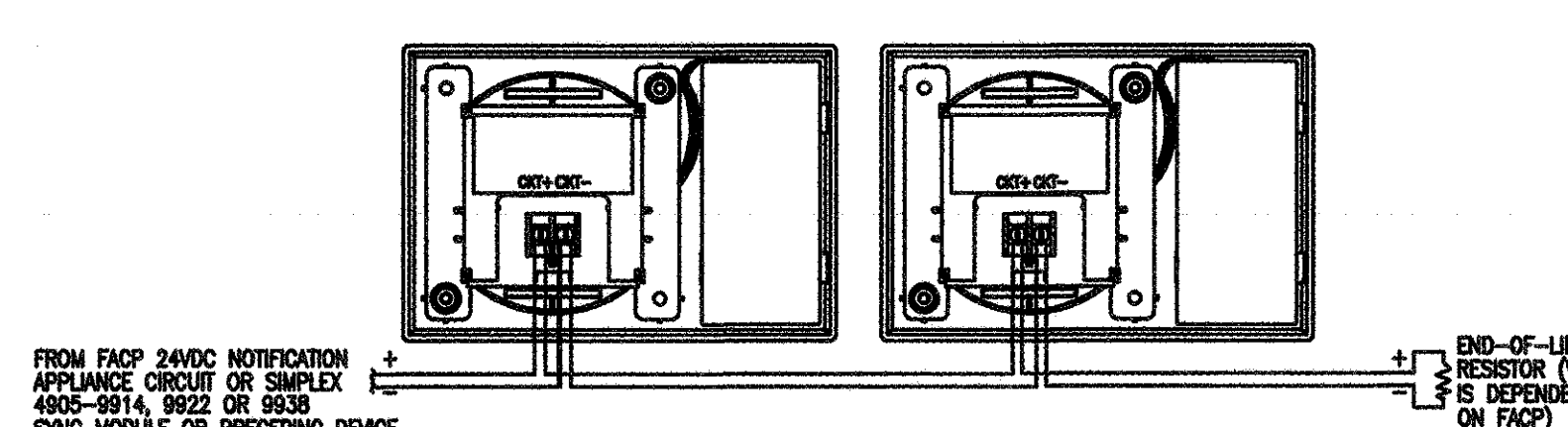
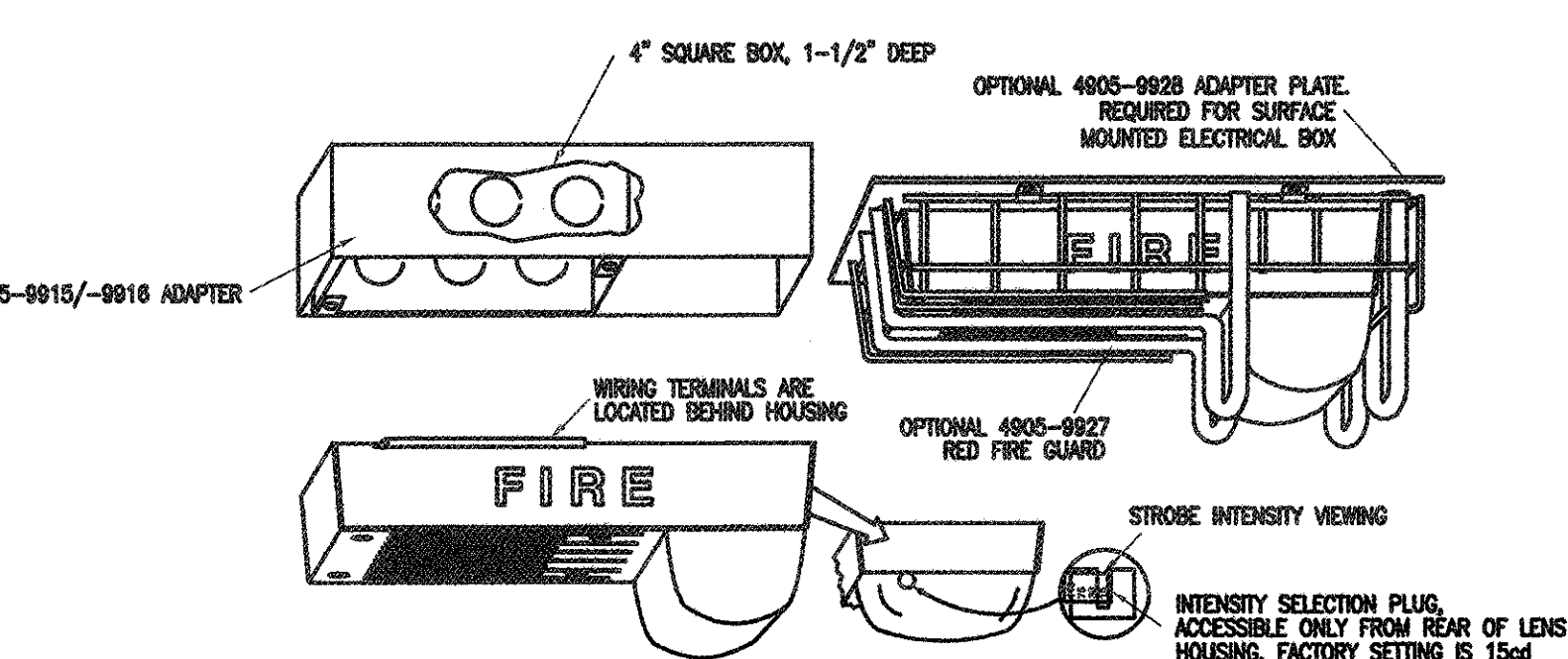

LITTLE
DIVERSIFIED ARCHITECTURAL CONSULTING

1300 Dova Street, Suite 100
Newport Beach, CA 92660
T: 949.698.1400 F: 949.698.1433

www.littleonline.com

This drawing and its design shall be the property of Little Diversified Architectural Consulting. The reproduction, copying or other use of this drawing without their written consent is prohibited and any infringement will be subject to legal action.

© Little 2016

**COMPTON
CCD**

CAMPUS PUBLIC SAFETY BUILDING

**1111 EAST ARTESIA BOULEVARD,
COMPTON CALIFORNIA 90221**

IDENTIFICATION STAMP
DIV. OF THE STATE ARCHITECT
OFFICE OF REGULATION SERVICES

FILE NO: 19-C1
AR: 03-117673
DATE: DEC 12 2017

10516 dHA + CALPEC

150 S. AEROTO PARKWAY
SUITE NO. 100
PALMDENA, CA. 91366
TEL: (826) 446-8650
FAX: (826) 446-8681

PRINCIPAL IN CHARGE
KEVIN CHEN
PROJECT MANAGER

DRAWN BY
dHA+CALPEC

NO REASON DATE

REGISTERED PROFESSIONAL ENGINEER
ANDREW H. HENDON
E-13884
Exp. 06/30/24
STATE OF CALIFORNIA

FIRE ALARM DETAILS

913-4675-01

11/21/2017 FA0.3.2

VOLTAGE DROP CALCULATION

NOTIFICATION CIRCUIT DESCRIPTION	Power Supply	Panel Circuit	Plan Ckt.	Dist. (Ft)	Wire Gauge	Wire Res. / Ft. (R)	Total Alarm (A)	V. Drop (V)	V. Drop @ End	% Volt Drop	Min Device Voltage	Max Distance	Circuit				Minimum Voltage @ NAC	Spare Circuit /	Device Quantity Per	
													Capacity (Amps)	Output Terminals	Branch Capacity	Circuit/ Branch				
CAMPUS PUBLIC SAFETY BUILDING STROBE	SPS-1	SP1	V1	300	12ga	0.0020	1.983	2.420	17.075	12.43%	16vdc	433 Ft.	5	4	3	2	3.4	19.5	30.7%	14
	SPS-1	STG2	V2	300	12ga	0.0020	1.431				16vdc	433 Ft.	1	2	6	3	3.4	19.5		12
	SPS-1	STG3	V2	300	12ga	0.0020	0.375				16vdc	433 Ft.	1		5		3.4	19.5		6

NOTE:
LUMP SUM METHOD WAS USED TO CALCULATE ALLOWABLE VOLTAGE DROP. THIS METHOD ALLOWS FOR A SMALL MARGIN OF SAFETY, TAKING INTO CONSIDERATION THAT THE ACTUAL INSTALLED CIRCUIT ROUTING MAY DIFFER FROM WHAT IS SHOWN ON THE SHOP DRAWINGS. IF THE ACTUAL CIRCUIT LENGTH IS GOING TO EXCEED THE MAXIMUM ALLOWABLE CIRCUIT LENGTH, CONTACT YOUR LOCAL SIMPLEXGRINNELL DISTRICT OFFICE.

CERTIFICATE OF COMPLIANCE
COVER PAGE

MARIA GUIDO
SIMPLEXGRINNELL L.P.
14200 E Exposition Ave
Aurora CO 80012-2540

Applicant Subscriber No: 214821-001
Service Center Number: 28
Service Contract No.: -
ACTIVE LISTINGS
CCN File No. Vol. No.
UUFX 95242 3



Applicant ID No: 214821-001
Service Center No: 28
Expires: 31-MAR-2017

CERTIFICATE OF COMPLIANCE

THIS IS TO CERTIFY that the Alarm Service Company indicated below is included by Underwriters Laboratories Inc. (UL) in its Product Directories as eligible to use the UL Listing Mark in connection with Certified Alarm Systems. The only evidence of compliance with UL's requirements is the issuance of a UL Certificate for the Alarm System and the Certificate is current under UL's Certificate Verification Service. This Certificate does not apply in any way to the communication channel between the protected property and any facility that monitors signals from the protected property unless the use of a UL Listed or Classified Alarm Transport Company is specified on the Certificate.

Listed Service From: **AURORA, CO**

Alarm Service Company: (106570-534)	Service Center: (106570-534)
SIMPLEXGRINNELL L.P.	SIMPLEXGRINNELL L.P.
14200 E EXPOSITION AVE	14200 E EXPOSITION AVE
AURORA CO 80012-2540	AURORA CO 80012-2540

The Alarm Service Company is Listed in the following Certificate Service Categories:
File - Vol No. CCN Listing Category
S6242-3 UUFX (Signal and Fire Alarm Equipment and Services) (Protective Signaling Services) Central Station

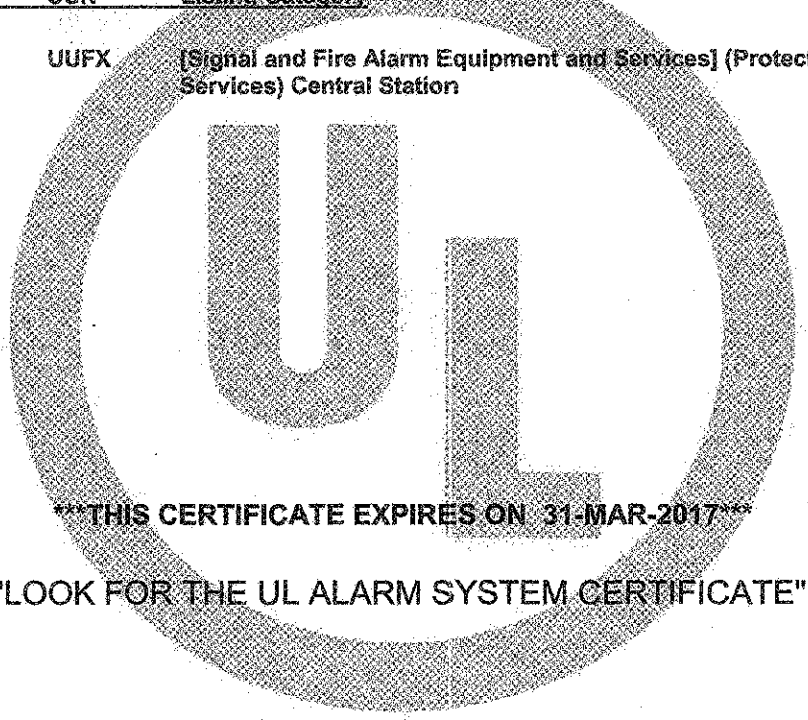

THIS CERTIFICATE EXPIRES ON 31-MAR-2017
"LOOK FOR THE UL ALARM SYSTEM CERTIFICATE"

Listed Service From: AURORA, CO

Alarm Service Company:
SIMPLEXGRINNELL L.P.
14200 E EXPOSITION AVE
AURORA CO 80012-2540

Service Center:
SIMPLEXGRINNELL L.P.
14200 E EXPOSITION AVE
AURORA CO 80012-2540

Module	Qty	Description	Standby Current	Total Standby	Alarm Current	Total Alarm
CAMPUS PUBLIC SAFETY BUILDING 4100e FACP						
Panel Equipment						
4100-9114	1	4100 MASTER CONTROLLER, INFO-ALARM DISPLAY	0.4450	0.4450	0.5000	0.5000
Panel Totals			0.4450	0.4450	0.5000	0.5000
IDNet Addressable Devices (SLC)						
4089-9021	2	ADDRESSABLE SINGLE ACTION NO GRIP PULL STATION	*			
4089-9714	36	TRUEALARM PHOTO SMOKE SENSOR	*			
4089-9782	36	TRUEALARM SENSOR BASE	*			
Notification Appliances						
4906-9101	15	1/0 MC NON-ADDRESS, RED, WALL	15	0.0000	0.0000	0.0800
4906-9127	5	A/V MC NON-ADDRESS, RED, WALL	15	0.0000	0.0000	0.0750
4906-9127	1	A/V MC NON-ADDRESS, RED, WALL	75	0.0000	0.0000	0.2210
4906-9131	5	WP MC A/V NON-ADDR WALL MT RED	WP75	0.0000	0.0000	0.2770
Peripheral Totals			0.0000	0.0000	0.0000	2.4010
Added Current for EPS Conversion of 24 to 29 Volt IDNet Devices			0.0000	0.0000	0.0000	0.0000
RUF Totals			0	0.0000	0.0000	0.0000
Address Totals			20 Addresses	0.0180	0.0180	0.0200
* Device Address current draw included below (See Additional Current Draw):			System Totals:	Standby	Alarm	2.9210

Battery Set #1 (Cabinet/Charger #1)	Standby Current	Standby Total	Alarm Current	Alarm Total
Select All Power Supplies on this battery set:				
SPS-1		0.4450		2.9010
Sub Total		0.4450		2.9010
Additional Current Draw:				
MANNET/IDNet Device Address Communication Current	20	x 0.000800	= 0.0160	x 0.001000 = 0.0200
Sub Total		0.4610		2.9210
Spare addressable point capacity				
0	x 0.0008	= 0.0000	x 0.001	= 0.0000
Total		0.4610		2.9210
Standby Time = 24 Hrs				
Standby		x 0.4610	= 11.0640	Standby Ah
Alarm Time = 5 Min				
Alarm		0.08333 x 2.921	= 0.2434	Alarm Ah
Additional Spare Battery Capacity = 0%		+	11.3074	
Battery Discharge Factor = 20%		+	0.0000	
Minimum Battery Required 2081-9275 18AH (2x)		+	11.3074	
Battery Supplied 2081-9287 25AH (2x)		+	2.2616	
13.5690				

* System Totals represent total system current requirements. These currents may be distributed between multiple battery sets or power supplies as shown above.

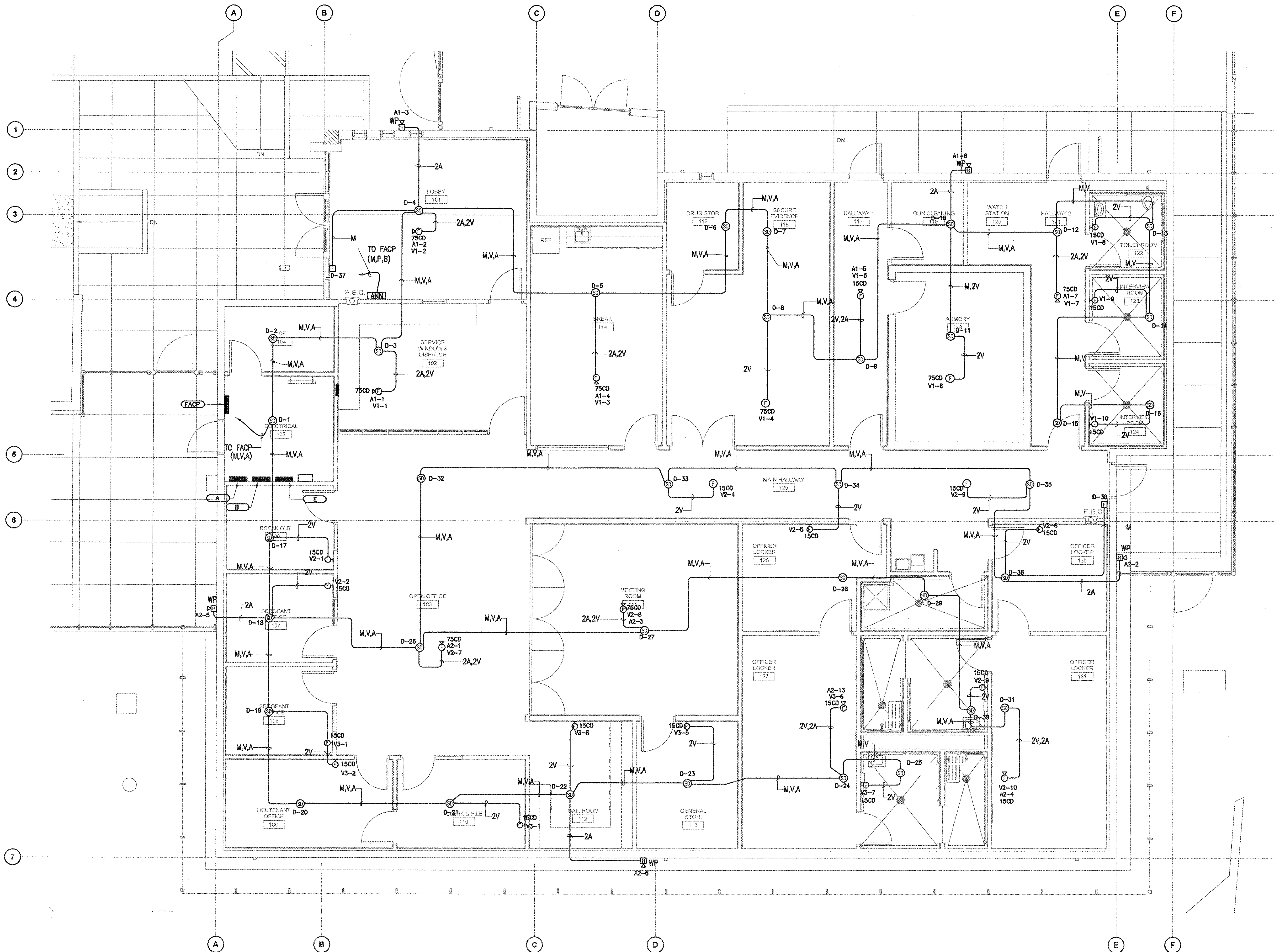

1 FIRE ALARM PLAN
1/4" = 1'-0"

LITTLE
DIVERSIFIED ARCHITECTURAL CONSULTING
1300 Dove Street, Suite 100
Newport Beach, CA 92660
T: 949.698.1400 F: 949.698.1433
www.littleonline.com
This drawing and the design shown are the property of Little Diversified Architectural Consulting. The reproduction, copying or other use of this drawing without their written consent is prohibited and any infringement will be subject to legal action.
© Little 2016

**COMPTON
CCD**

CAMPUS PUBLIC SAFETY BUILDING
1111 EAST ARTESIA BOULEVARD,
COMPTON CALIFORNIA 90221

IDENTIFICATION STAMP
DIV. OF THE STATE ARCHITECT
OFFICE OF REGULATION SERVICES
FILE NO: 18-C1
AR: 03-17673
AC: [Signature] FS: [Signature] SS: [Signature] PD
DATE: DEC. 12, 2017

16516
dHA + CALPEC
180 S. ARROYO PARKWAY
SUITE NO. 100
PASADENA, CA 91106
TEL: (626) 445-8880
FAX: (626) 445-8081

PRINCIPAL IN CHARGE
KEVIN CHEN
PROJECT MANAGER
DRAWN BY
dHA+CALPEC

NO	REASON	DATE



FIRE ALARM PLAN

913-4675-01

11/21/2017 FA2.1